

Step Motors K, M, N, P Series



Helping you build a better machine, faster.

Stepper Motor Series P, M, N, K

Stepper Motor Series P, M, N, K These frame hybrid steppers from Danaher Motion provide an excellent torque to frame size ratio. Optimized magnetics in combination with a new rotor/stator design produce more torque and a higher acceleration. This unique design also features low detent torque for smoother microstepping. Series M and K are equipped with additional magnets in the stator slots (Simax®) for additional torque increase at identical motor size.

Powermax (Series P and M)

The motors in size NEMA 23 have an octagonal housing. In standard version all motors have an 8-pole connector.

Powerpac (Series N and K)

The motors in size NEMA 34 and 42 have a square housing. In standard version all motors have an 8-pole flying lead connection.

Motor Design

Powermax Series P, M

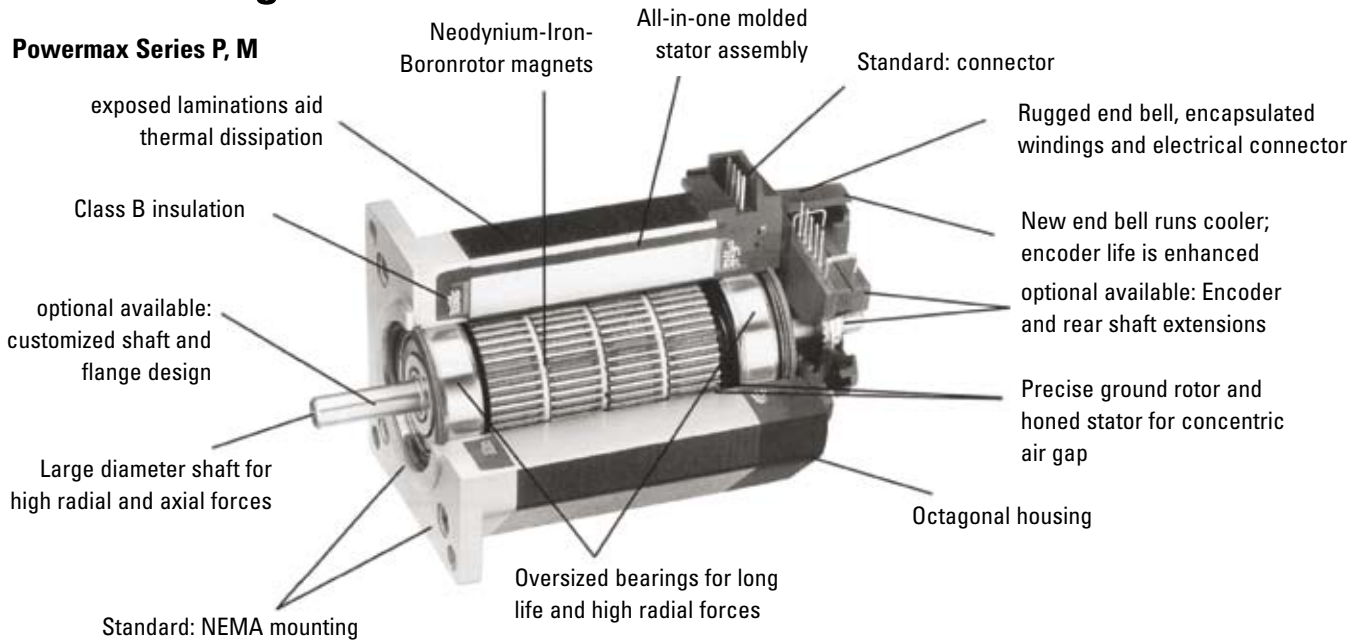

Powerpac Series N, K

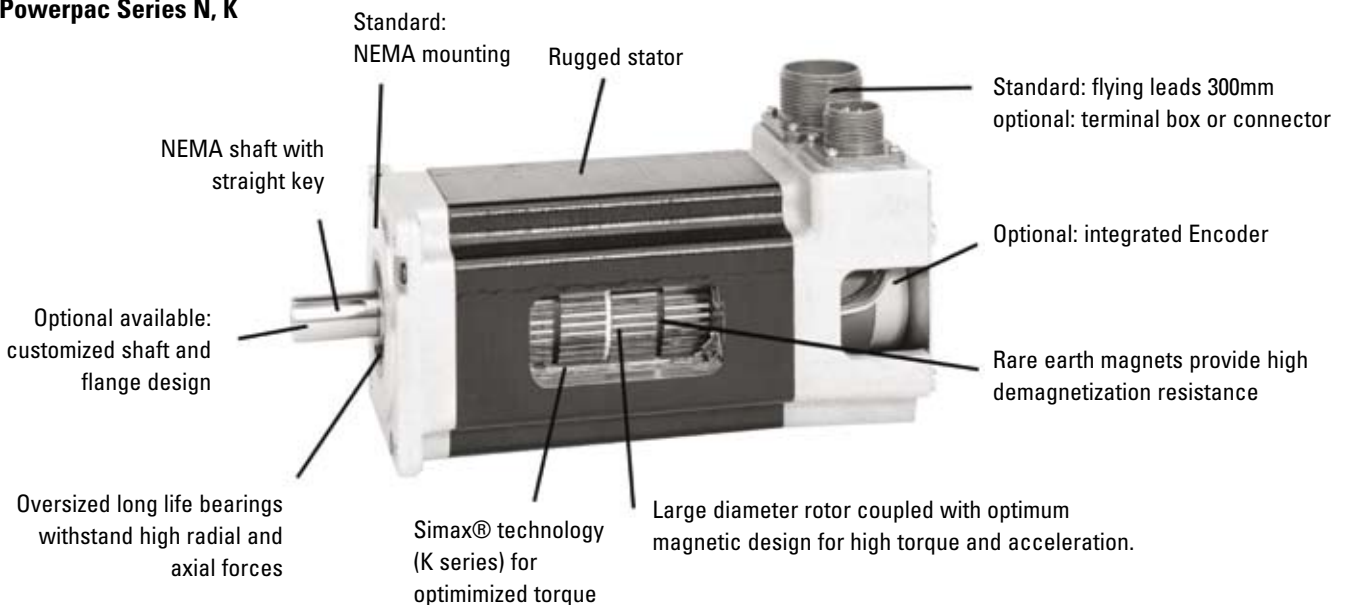

Features

Powermax Series M and P

- 2-phase hybrid stepper motor in size NEMA 23
- Smooth shaft \varnothing 6,35 mm
- Full step angle 1,8°
- Fully encapsulated stator
- Protection class IP 23
- Oversized bearings withstand high radial and axial loads
- Optimized housing design for cooling
- CE certification
- Highest dynamics at shortest positioning times
- 8 pin connector for serial or parallel connection



Powerpac Series N and K

- 2-phase hybrid stepper motor in size NEMA 34 and NEMA 42
- Shaft with straight keyway
- Full step angle 1,8°
- Optimized magnetic design for increased performance
- Protection class IP 44 (optional IP 65, with terminal box)
- Longlife steel bearing bore in front bell
- Optimized housing design for cooling
- CE certification, UL certification (motor insulation class B, File E03510)
- 8 flying leads for serial or parallel connection



Options

- several feedback options
- several gearhead options
- brake
- double shaft
- several connection options
- low inertia rotor

Optimized Magnetic Flux

Series M and K are equipped with additional magnets in the stator slots (Sigmax® technology). The non-torque producing flux is reduced, this increases torque by 20 to 30% at the same dimensions and windings.

Standard: Series N and P

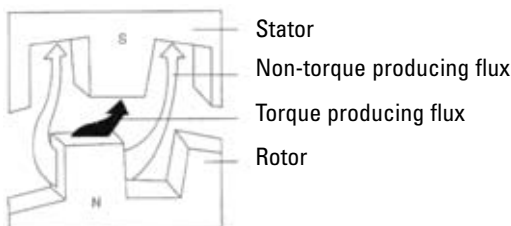

Typical path of flux transfer in an energized conventional hybrid step motor. Some flux leakage occurs in normal operation.

Sigmax® : Series K and M

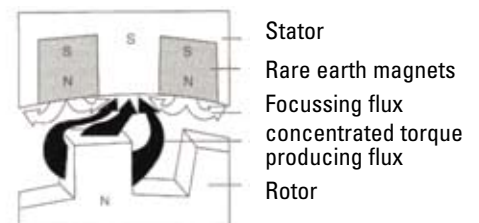

Patented Sigmax® technology redirects magnetic flux to inhibit leakage and optimize torque production.

Technical Data

	Type	Holding torque per winding [Nm]	Rated current per winding [A]	Resistance per winding [Ohm]	Inductance per winding [mH]	Detent torque [Nm]	Rotor inertia [kgm ² *10 ⁻³]	Weight [kg]
POWERMAX	P2HN--F	0,42	1,6	3,80	5,1	0,018	0,007	0,45
	P2HN--C	0,43	2,5	1,68	2,3	0,018	0,007	0,45
	P2HN--H	0,42	5,2	0,44	0,5	0,018	0,007	0,45
	P21N--D	0,77	1,5	5,22	10,3	0,03	0,012	0,68
	P21N--C	0,82	3,5	1,06	2,3	0,03	0,012	0,68
	P21N--B	0,79	4,6	0,64	1,1	0,03	0,012	0,68
	P21N--A	0,81	5,6	0,46	0,8	0,03	0,012	0,68
	M21N--D	0,95	1,5	5,22	8,7	0,066	0,012	0,68
	M21N--C	1,02	3,5	1,06	2,0	0,066	0,012	0,68
	M21N--B	0,97	4,6	0,64	1,0	0,066	0,012	0,68
	M21N--A	1,00	5,6	0,46	0,7	0,066	0,012	0,68
	P22N--D	1,43	2,5	2,44	6,2	0,05	0,025	1,13
	P22N--C	1,43	3,1	1,56	3,9	0,05	0,025	1,13
	P22N--B	1,51	4,6	0,76	2,1	0,05	0,025	1,13
	P22N--A	1,39	6,5	0,42	0,8	0,05	0,025	1,13
	M22N--D	1,68	2,5	2,44	5,0	0,12	0,025	1,13
M22N--C	1,68	3,1	1,56	3,1	0,12	0,025	1,13	
M22N--B	1,79	4,6	0,76	1,7	0,12	0,025	1,13	
M22N--A	1,62	6,5	0,42	0,7	0,12	0,025	1,13	
POWERPAC	N31H--H	4,5	2,8	3,10	12,5	0,13	0,14	2,3
	N31H--J	4,5	5,5	0,84	3,5	0,13	0,14	2,3
	N31H--K	4,7	6,6	0,58	2,6	0,13	0,14	2,3
	N31H--L	4,6	8,6	0,36	1,4	0,13	0,14	2,3
	K31H--H	5,7	2,8	3,10	10,2	0,18	0,14	2,3
	K31H--J	5,8	5,5	0,84	2,8	0,18	0,14	2,3
	K31H--K	6,0	6,6	0,58	2,1	0,18	0,14	2,3
	K31H--L	5,9	8,6	0,36	1,2	0,18	0,14	2,3
	N32H--J	8,4	5,1	1,27	6,5	0,25	0,27	3,8
	N32H--K	8,8	6,1	0,90	5,1	0,25	0,27	3,8
	N32H--L	8,5	8,1	0,52	2,6	0,25	0,27	3,8
	N32H--M	8,6	10,0	0,35	1,8	0,25	0,27	3,8
	K32H--J	10,7	5,1	1,27	5,1	0,35	0,27	3,8
	K32H--K	11,1	6,1	0,90	4,0	0,35	0,27	3,8
	K32H--L	10,7	8,1	0,52	2,0	0,35	0,27	3,8
	K32H--M	10,8	10,0	0,35	1,4	0,35	0,27	3,8
	N33H--J	12,1	5,0	1,65	9,0	0,38	0,4	5,4
	N33H--K	12,4	6,1	1,12	6,4	0,38	0,4	5,4
	N33H--L	13,0	9,0	0,53	3,4	0,38	0,4	5,4
	N33H--M	12,1	9,9	0,44	2,3	0,38	0,4	5,4
	K33H--J	15,1	5,0	1,65	7,0	0,53	0,4	5,4
	K33H--K	15,6	6,1	1,12	5,0	0,53	0,4	5,4
	K33H--L	16,5	9,0	0,53	2,6	0,53	0,4	5,4
	K33H--M	15,2	9,9	0,44	1,2	0,53	0,4	5,4
	N34H--J	15,3	5,5	1,60	11,5	0,4	0,53	6,8
	N34H--K	14,4	6,0	1,35	8,1	0,4	0,53	6,8
	N34H--L	15,4	8,7	0,66	4,7	0,4	0,53	6,8
	N34H--M	15,1	11,3	0,44	2,6	0,4	0,53	6,8
	K34H--J	19,6	5,5	1,60	8,9	0,5	0,53	6,8
	K34H--K	18,2	6,0	1,35	6,3	0,5	0,53	6,8
	K34H--L	19,7	8,7	0,66	3,6	0,5	0,53	6,8
	K34H--M	19,2	11,3	0,41	2,0	0,5	0,53	6,8
	N41H--J	11,5	5,5	1,16	10,1	0,3	0,55	2,3
	N41H--L	11,5	8,7	0,47	3,9	0,3	0,55	2,3
	N41H--M	11,7	10,7	0,31	2,8	0,3	0,55	2,3
	K41H--J	14,8	5,5	1,16	7,8	0,46	0,55	2,3
	K41H--L	14,8	8,7	0,47	3,1	0,46	0,55	2,3
	K41H--M	15,1	10,7	0,31	2,2	0,46	0,55	2,3
	N42H--K	21,9	6,4	1,20	12,8	0,59	1,09	8,3
	N42H--L	21,8	8,1	0,75	7,8	0,59	1,09	8,3
N42H--M	22,2	9,9	0,51	5,5	0,59	1,09	8,3	
N42H--N	22,1	15,8	2,10	2,1	0,59	1,09	8,3	
K42H--K	28,0	6,4	1,20	9,8	0,69	1,09	8,3	
K42H--L	27,8	8,1	0,75	6,0	0,69	1,09	8,3	
K42H--M	28,4	9,9	0,51	4,2	0,69	1,09	8,3	
K42H--N	28,2	15,8	2,10	1,6	0,69	1,09	8,3	
N43H--K	30,6	6,2	1,65	19,6	0,75	1,62	11,6	
N43H--L	30,0	8,0	0,99	11,0	0,75	1,62	11,6	
N43H--M	30,5	9,9	0,66	7,7	0,75	1,62	11,6	
N43H--N	30,8	15,4	0,28	3,2	0,75	1,62	11,6	
K43H--K	39,3	6,2	1,65	15,2	0,83	1,62	11,6	
K43H--L	39,0	8,0	0,99	8,5	0,83	1,62	11,6	
K43H--M	39,7	9,9	0,66	5,9	0,83	1,62	11,6	
K43H--N	40,2	15,4	0,28	2,5	0,83	1,62	11,6	

Standard

Sigmax®

Dimensions

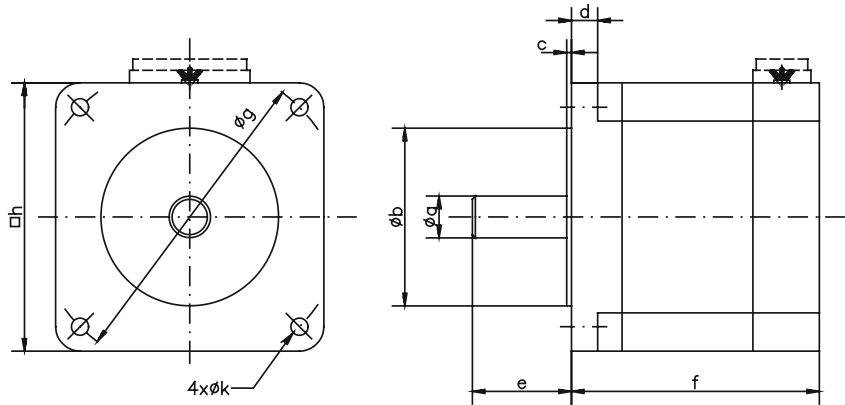

Type	a/mm	b/mm	c/mm	d/mm	e/mm	f/mm	g/mm	h/mm	k/mm
P2Hxxxx	6,35	38,1	1,4	5,1	20,60	40,7	66,67	57,10	5,08
P/M21xxxx	6,35	38,1	1,4	5,1	20,60	52,4	66,67	57,10	5,08
P/M22xxxx	6,35	38,1	1,4	5,1	20,60	78,8	66,67	57,10	5,08
N/K31xxxx	12,70	73,0	1,5	8,4	31,75	79,5	98,43	86,00	5,60
N/K32xxxx	12,70	73,0	1,5	8,4	31,75	118,0	98,43	86,00	5,60
N/K33xxxx	15,88	73,0	1,5	8,4	31,75	157,0	98,43	86,00	5,60
N/K34xxxx	15,88	73,0	1,5	8,4	31,75	195,0	98,43	86,00	5,60
N/K41xxxx	19,05	55,52	1,52	12,2	55,63	98,81	125,72	109,86	8,33
N/K42xxxx	19,05	55,52	1,52	12,2	55,63	150,11	125,72	109,86	8,33
N/K43xxxx	19,05	55,52	1,52	12,2	55,63	201,17	125,72	109,86	8,33

Order Code

N 3 3 H C H J - L E K - N S - 0 1

Series

- P - Standard (Powermax)
- M - Sigmax® version (Powermax)
- N - Standard (Powerpac)
- K - Sigmax® version (Powerpac)

Size

- 2 - NEMA 23 (57,15 mm Ø) (Powermax only)
- 3 - NEMA 34 (96,52 mm Ø) (Powerpac only)
- 4 - NEMA 42 (109,85 mm Ø) (Powerpac only)

Number of Rotor Stacks

- H - 1/2 stack (Powermax only)
- 1 - 1 stack
- 2 - 2 stack
- 3 - 3 stack (Powerpac only)
- 4 - 4 stack (Powerpac only)

Mounting Configuration

- N - NEMA (Powermax only)
- H - Heavy Duty NEMA (Powerpac only)
- S - Special (upon request)

Construction/Hookup

- R - Regular
- C - System MS connector (Powerpac only)
- L - Splashproof/to terminal board via conduit connector: 1/2" NPS pipe thread (Powerpac only)
- M - Splashproof/to terminal board via conduit connector: metric PG11 pipe thread (Powerpac only)
- S - Special (upon request)

Winding/Leads

- x - Receptacle (Powermax only) - Please order cable separately!
- F - 8 lead (n/a C construction)
- L - 4 lead series
- H - 4 lead parallel
- E - 6 lead (n/a C construction) (Powerpac only)

Special Sequence

- 00 - Standard motor, no shaft seal
- 01 - Standard motor with shaft seal (Powerpac only)
- xx - Numbers assigned for special motors (upon request)

Encoder Options

- NS - No feedback
- xx - Several encoders available (upon request)
- M1 - Encoder mounting provision (Powermax only)
- M2 - Encoder mounting provision (Powerpac only)
- SS - Special (upon request)

Shaft Modifications

- N - Smooth (Powermax only)
- F - Flat
- K - Straight key (Powerpac only)
- S - Special (upon request)

Shaft Configuration

- N - Single
- D - Double (R and C construction only)
- E - Double ended for encoder
- S - Special (upon request)

Rotor Types

- L - Laminated
- J - Low inertia (Powermax only, n/a for 1/2 stack)

Winding Types

- A-N - Refer to winding data
- S - Special (upon request)

United Kingdom

Danaher Motion
Chartmoor Road, Chartwell Business Park
Leighton Buzzard, Bedfordshire
LU7 4WG; United Kingdom
Phone: +44 (0)1525 243 243
Fax: +44 (0)1525 243 244
E-mail: sales.uk@danahermotion.com

France

Danaher Motion
C.P 80018
12, Rue Antoine Becquerel – Z.I. Sud
F – 72026 Le Mans Cedex 2
France
Phone: +33 (0) 243 50 03 30
Fax: +33 (0) 243 50 03 39
E-mail: sales.france@danahermotion.com

Germany

Danaher Motion GmbH
Sales Office North
Wacholderstr. 40-42
40489 Düsseldorf
Germany
Phone: +49 (0) 203 9979 214
Fax: +49 (0) 203 9979 3214
E-Mail: iris.tolusch@danahermotion.com

Danaher Motion GmbH
Sales Office South West
Lessingstr. 41
75015 Bretten
Germany
Phone: +49 (0) 7252 97390 56
Fax: +49 (0) 7252 97390 55
E-Mail: kerstin.mueller@danahermotion.com

Danaher Motion GmbH
Sales Office South East
Kiesgräble 7
89129 Langenau
Germany
Phone: +49 (0) 7471 62 23 23
Fax: +49 (0) 7471 62 23 26
E-Mail: ursula.koschak@danahermotion.com

Italy

Danaher Motion srl
Largo Brughetti 1/B2
I - 20030 Bovisio Masciago
Italy
Phone: +39 0362 594260
Fax: +39 0362 594263
E-mail: info@danahermotion.it

Sweden

Danaher Motion Stockholm AB
Solkraftsvägen 13
135 70 Stockholm
Sweden
Phone: +46 (0) 8-682 64 00
Fax: +46 (0) 8-682 65 80
E-mail: sales.scandinavia@danahermotion.com

Switzerland

Danaher Motion SA
La Pierreire 2
1029 Villars-Ste-Croix
Switzerland
Phone: +41 (0) 21 631 33 33
Fax: +41 (0) 21 636 05 09
E-mail: info@danaher-motion.ch

USA, Canada or Mexico

Danaher Motion
203A West Rock Road
Radford, VA 24141 USA
Phone: 1-540-633-3400
Fax: 1-540-639-4162
E-mail: DMAC@danahermotion.com

China

Danaher Motion
Rm 2205, Scitech Tower
22 Jianguomen Wai Street
Beijing, China, 100004
Phone: +86 10 6515 0260
Fax: +86 10 6515 0263
E-mail: chinainfo@danahermotion.com.cn

Japan

Danaher Motion Japan
2F, Tokyu Reit Hatchobori Bldg,
2-7-1 Hatchobori Chuo-ku,
Tokyo 104-0032 Japan
Phone: +81-3-6222-1051
Fax: +81-3-6222-1055
E-mail: info@danahermotion.co.jp

Asia Pacific

Danaher Motion (HK) Ltd
Unit A, 16 Floor, 169 Electric Road
Manulife Tower, North Point
Hong Kong
Phone: +852 2503 6581
Fax: +852 2571 8585
E-mail: victor.lim@danahermotion.com

