

RoundRail Linear Guides and Components

Linear Ball Bushing Bearings[®], 60 Case Shafting[®] and RoundRail Linear Guides



Linear Motion. Optimized.™

Thomson – the Choice for Optimized Motion Solutions

Often the ideal design solution is not about finding the fastest, sturdiest, most accurate or even the least expensive option. Rather, the ideal solution is the optimal balance of performance, life and cost.

The Best Positioned Supplier of Mechanical Motion Technology

Thomson has several advantages that make us the supplier of choice for motion control technology.

- Thomson provides the broadest standard product offering of mechanical motion technologies in the industry.
- Modified versions of standard product or white sheet design solutions are routine for us.
- Choose Thomson and gain access to over 70 years of global application experience in industries including packaging, factory automation, material handling, medical, clean energy, printing, automotive, machine tool, aerospace and defense.
- As part of Danaher Corporation, we are financially strong and unique in our ability to bring together control, drive, motor, power transmission and precision linear motion technologies.

A Name You Can Trust

A wealth of product and application information as well as 3D models, software tools, our distributor locator and global contact information is available at www.thomsonlinear.com. For assistance, contact your local sales office (contact information listed on the back of catalog). Talk to us early in the design process to see how Thomson can help identify the optimal balance of performance, life and cost for your next application. And, call us or any of our 2000+ distribution partners around the world for fast delivery of replacement parts.

The Danaher Business System

The Danaher Business System (DBS) was established to increase the value we bring to customers. It is a mature and successful set of tools we use daily to continually improve manufacturing operations and product development processes. DBS is based on the principles of Kaizen which continuously and aggressively eliminate waste in every aspect of our business. DBS focuses the entire organization on achieving breakthrough results that create competitive advantages in quality, delivery and performance – advantages that are passed on to you. Through these advantages Thomson is able to provide you faster times to market as well as unsurpassed product selection, service, reliability and productivity.

Local Support Around the Globe

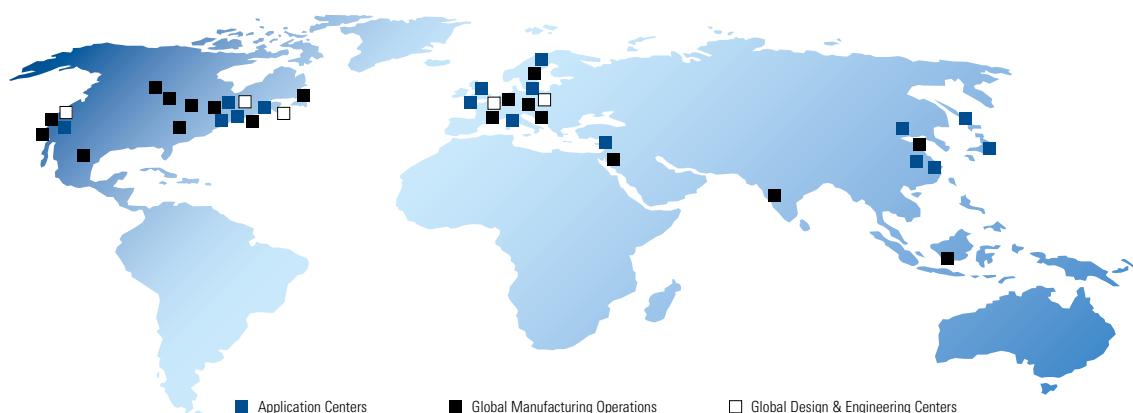

Table of Contents

Introduction	4 - 14	Support Block	199
Linear Bearings*	15 - 157	Quick Shaft	200 - 203
Inch Ball Bushing Bearings	15 - 121	Special Machining	204 - 225
Lube for Life.....	22	RoundRail Linear Guides	226 - 260
Super Smart Ball Bushing Bearings	23 - 29	End Support 1BA.....	237 - 238
Super Smart Ball Bushing Pillow Blocks	30 - 45	End Support 1NA	239 - 240
Super Ball Bushing Bearings	46 - 54	Continuous Support 1CA	242 - 243
Super Ball Bushing Pillow Blocks	55 - 68	Continuous Support 1PA.....	244 - 245
Precision Steel Ball Bushing Bearings.....	69 - 77	FluoroNyliner 1VA.....	246 - 247
Precision Steel Ball Bushing Pillow Blocks..	78 - 89	Side Mounted 1DA	249 - 251
XR Extra Rigid Ball Bushing Bearings.....	90 - 93	Dual Shaft Rail 2DA	252 - 254
XR Extra Rigid Ball Bushing Pillow Blocks....	94 - 96	Twin Shaft Web 2CA.....	255 - 257
Specialty Bearings	97 - 121	Accessories.....	258 - 261
RoundWay* Linear Roller Bearings	97 - 104	Engineering	262 - 280
FluoroNyliner* Bushing Bearings.....	105 - 115	Performance Criteria	263 - 264
Food Grade FluoroNyliner*	116 - 118	Ball Bushing Life Expectancy and	
Accessories	119 - 123	Load Capacity	266 - 268
Metric Ball Bushing Bearings	125 - 161	60 Case* LinearRace* Shafting	
General Product Overview	122 - 126	Specifications	269
Super Smart Ball Bushing Bearings	127 - 135	Load Consideration	270
Super Smart Ball Bushing Pillow Blocks ..	136 - 147	Coefficient of Friction.....	271
MultiTrac* Ball Bushing Bearings.....	148 - 155	Lubrication	272
Super Metric Ball Bushing Bearings	156 - 159	System Replacement Components.....	272
Super Metric Pillow Blocks.....	160 - 166	System Maintenance and Service	272
Accessories	167 - 169	Bearing Options	273
60 Case* Shafting	170 - 225	Material Engineering Specifications.....	274
60 Case Size and Availability	170 - 172	60 Case LinearRace Deflection	275
60 Case Product Overview	173 - 177	Ultra Light Aluminum LinearRace Deflection.....	276
Inch 60 Case Shafting	180 - 192	How to Cut 60 Case LinearRace Shafting	277
Support Rails and Support Rail		Application Tips	278
Assemblies	186 - 189	Installation Guidelines	279
Support Block	190 - 192	Tolerance Charts.....	280 - 281
Metric 60 Case Shafting	193 - 199	Engineering Conversion Factors.....	281
Support Rails and Support Rail		Shafting Color Code Chart.....	283
Assemblies	196 - 198		

*Trademark of Thomson Industries, Inc. Thomson Industries, Inc. is registered in the U.S. Patent and Trademark Office and in other countries.

Thomson RoundRail Linear Guides and Components Overview

Linear Bearings

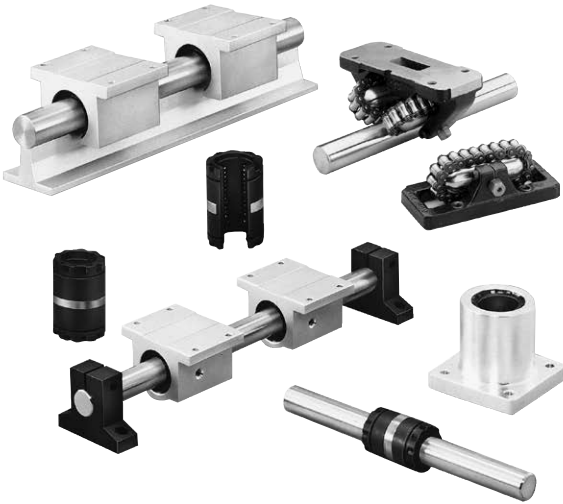

Thomson offers an extensive family of Linear Bearings. Super Smart Ball Bushing Bearings are available in Inch and Metric sizes. Thomson uses the latest technology - Universally self-aligning Bearings. These Bearings are offered in a Dual Track Design and offer Load Capacities up to 7,760 lb_f (30,000N). The Super Smart Ball Bushing Bearings are available in sizes .5 in to 1.5 in, 8 mm to 40mm. Super Ball Bushing Pillow Blocks are available in closed, adjustable and open styles in both single and twin versions. These are the original self aligning precision anti-friction linear bearing with load capacities up to 4,000 lb_f, and speed up to 10 ft/sec (3 m/s). Thomson offers the largest selection of sizes. 'A' Bearings are the original precision anti-friction linear bearing all steel construction with load capacities up to 5,000 lb_f and high operating temperature capabilities. Thomson Die Set

Ball Bushing Bearings offer high operating temperature capabilities, all steel construction and load capacities up to 1100 lb_f. Roundway Bearings are capable of load capacities up to 24,000 lb_f, with travel speeds up to 100 ft/sec. These Bearings offer high performance in highly contaminated environments. FluoroNyliner Ball Bushing Bearings are recommended for washdown and contaminated environments. These Bearings and pillow blocks offer load capacities up to 14,000 lb_f.

Shafting



While Shafts may appear the same, there are significant performance differences due to the manufacturer's selected standards, and the manufacturing processes used to achieve them. The linear inner race demands the highest levels of material cleanliness, surface topography, surface hardening, diameter, taper and roundness, surface finish and straightness to provide optimum performance, minimal maintenance and long life. Unlike common shafting, Thomson 60 Case LinearRace shafting is manufactured to the highest quality standards. Our techniques are continuously upgraded with proprietary know-how gained from over 53 years of linear bearing design and manufacture. Using 60 Case LinearRace shafting with Thomson Ball Bushing Bearings ensures optimal bearing performance and travel life.

*Trademark of Thomson Industries, Inc. Thomson Industries, Inc. is registered in the U.S. Patent and Trademark Office and in other countries.

Thomson Product Line Overview

RoundRail Linear Guides

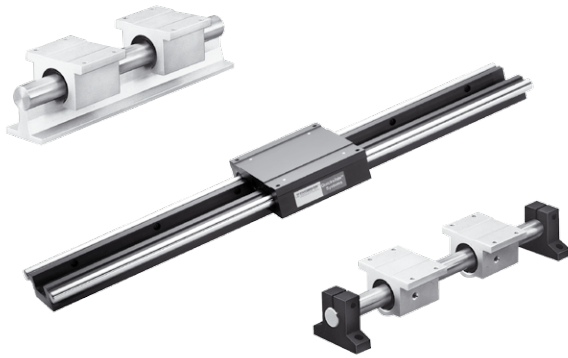

Pre-assembled, ready to install stages providing low friction, smooth, accurate motion for a wide range of moment or normal loading configurations. Market applications include factory automation, medical, packaging, machine tool, semiconductor, printing, automotive assembly, aerospace and food processing. Slide tables are available as customizable RoundRail Linear Guides to multiaxis, turnkey systems complete with motors, drives, controls and electromechanical accessories.

- Applications-typically on factory machinery where accurate, smooth linear positioning is required
- Available with servo/stepper motor & drive packages
- Max thrust to 3100 lb
- Strokes to 120"
- Loads from 5 - 2000 lb
- Repeatability to 0.0002"

New Thomson Linear Ball Bushing Bearings

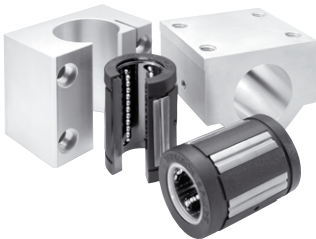

Metric Super Ball Bushing Bearings offer high performance from superior design

A coefficient of friction as low as 0,001. This allows the use of smaller less expensive motors, belts, gears and ball screws, when replacing high friction, plain bearings. A self-aligning capability up to 0.5° compensates for inaccuracies in base flatness or carriage machining. Achieved with Thomson Super Bearing plates which have defined radius crowns for maximized self-alignment accuracy. Accelerations as high as 150m/s² and steady state travel speeds up to 3 m/s without the derating factors commonly required with linear guides. Quick to ship, drop-in replacement parts for existing applications.







Stainless Steel MultiTrac and "A" Ball Bushing Bearings are ideal for harsh environments

Stainless steel (440) components resist rust and corrosion. "A" bearing withstands up to 600 degrees F (315°C). MultiTrac Ball Bushing bearings are rated at a maximum of 180 degrees F (82°C). MultiTrac has wear-resistant, engineered-polymer retainers to reduce inertia and noise levels. Quick to ship, drop-in replacement parts for existing applications:

*Trademark of Thomson Industries, Inc. Thomson Industries, Inc. is registered in the U.S. Patent and Trademark Office and in other countries.

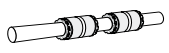
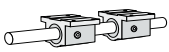
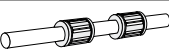
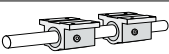
Thomson Product Line Overview

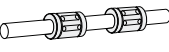
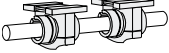
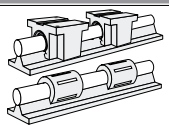
Ball Bushing Bearings

		Page Number	Imperial (Inch)							
			1/8	3/16	1/4	3/8	1/2	5/8	3/4	1
Super Smart										
	Ball Bushing Bearings corrosion resistant option available	inch: 23 metric: 127					○	○	○	○
	Ball Bushing Pillow Blocks corrosion resistant option available	inch: 30 metric: 136					○ STA	○ STA	○ STA	○ STA
Super										
	Ball Bushing Bearings corrosion resistant option available	inch: 46 & 59 metric: 156		□	□	□	○	○	○	○
	Ball Bushing Pillow Blocks corrosion resistant option available	inch: 55 & 64 metric: 160			□ STA	□ STA	○ STA	○ STA	○ STA	○ STA
Precision Bearings										
	A-Bearings and Pillow Blocks available in stainless steel	76			□	□ SA	○ SA	○ SA	○ SA	○ SA
	MultiTrac available in stainless steel	148								
	Instrument	80	□	□	□					
	Die Set	82								□
XR Extra Rigid										
	Ball Bushing Bearings and Pillow Blocks	90								
Specialty										
	Cartridge bearing	53			□ ST	□ ST	□ ST			
	RoundWay	97					□			□
FluoroNyliner										
	Bushing bearings	105				○	○	○	○	○
	Pillow Blocks	110				○ STF	○ STF	○ STF	○ STF	○ STF

- Closed Type
- Open Type
- Closed and Open Type
- S Single Configuration
- T Twin Configuration
- A Adjustable Configuration
- F Flanged Configuration

*Trademark of Thomson Industries, Inc. Thomson Industries, Inc. is registered in the U.S. Patent and Trademark Office and in other countries.

Thomson Product Line Overview

Imperial (Inch)						Metric (mm)										
1 1/4	1 1/2	2	2 1/2	3	4	5	8	10	12	16	20	25	30	35	40	50
⊙	⊙						□		⊙	⊙	⊙	⊙	⊙		⊙	
⊙	⊙						□		⊙	⊙	⊙	⊙	⊙		⊙	
STA	STA						STA		STA	STA	STA	STA	STA		STA	
⊙	⊙	⊙					□		⊙	⊙	⊙	⊙	⊙		⊙	⊙
⊙	⊙	⊙					□		⊙	⊙	⊙	⊙	⊙		⊙	⊙
STA	STA	STA					STA		STA	STA	STA	STA	STA		STA	STA
⊙	⊙	⊙	⊙	⊙	⊙											
SA	SA	SA	SA	SA	SA											
							□		⊙	⊙	⊙	⊙	⊙		⊙	
							SA		SA	SA	SA	SA	SA		SA	
□	□	□														
		○			○											
⊙	⊙	⊙														
⊙	⊙	⊙														
STF	STF	STF														

*Trademark of Thomson Industries, Inc. Thomson Industries, Inc. is registered in the U.S. Patent and Trademark Office and in other countries.

Thomson Product Line Overview

Standard 60 Case Shaft Size and Availability Chart

Material	Carbon Steel											440 C Stainless Steel			52100 Tubular		316 SS	Aluminum	
	60 min.											50 min.			55 min.	58 min.		20-25	70
Tolerance Class	L					S	N		D	XL	G	L	S	G	Instrument	L	S	L	AL
Optional Features	L	DC	PD CPPE	CPPE	PD	S	DC	N				L	PD						
1/8"																			
3/16"	•																		
1/4"	•					•		•			•	•		•					•
3/8"	•					•		•			•	•		•				•	•
1/2"	•		•	•	•	•		•			•	•	•	•				•	•
5/8"	•		•	•	•	•		•			•	•	•	•				•	•
3/4"	•	•	•	•	•	•		•			•	•	•	•		•	•	•	•
7/8"	•	•						•	•										
1"	•	•	•	•	•	•		•	•		•	•	•	•		•	•	•	•
1 1/8"	•	•						•	•										
1 1/4"	•	•	•	•	•	•		•	•			•	•	•				•	
1 3/8"	•							•											
1 1/2"	•	•	•	•	•	•		•	•			•	•	•		•	•	•	
1 5/8"	•							•											
1 3/4"	•	•						•	•										
2"	•	•	•	•	•	•		•	•	•		•	•	•		•	•		
2 1/4"	•	•						•	•										
2 1/2"	•	•				•		•	•			•		•			•	•	
3"	•	•				•		•	•		•					•	•		
3 1/2"	•	•																	
4"	•					•				•						•	•		
Catalog Page	179	181	180	180	180	179	181	179	179	179	182	182	182	183	183	183	183	184	185

Material	Carbon Steel			440 C SS
	60 min.			50 min.
Tolerance Class	MM (ISO h6)			MM (ISO h6)
Optional Features	MM	T1	T2	
5 mm	•			•
8 mm	•			•
10 mm	•			•
12 mm	•	•	•	•
15 mm	•			
16 mm	•	•	•	•
20 mm	•	•	•	•
25 mm	•	•	•	•
30 mm	•	•	•	•
40 mm	•	•	•	•
50 mm	•			•
60 mm	•			•
80 mm	•			
Catalog Page	193	194	194	195

Thomson 60 Case shafting is sold as cut-to-length (CTL), random length (RL), special machined (SM), and as quick shaft (QS).

Since Thomson grinds and hardens all of its own shafting, diameters and tolerances not listed are available as special grind and are made to order. Minimum lots may apply.

Tolerance Classes:

- L - For use with XA, Open and Adjustable Ball Bushing Bearings and Pillow Blocks as well as Super Ball Bushing Bearings and Super Smart Ball Bushing Bearings
- S - For use with A type ball bushings
- N - For use with needle roller Bearings
- D - For use with Thomson Die Set Ball Bushing Bearings
- G - Ball Grooved for use with Thomson Super Ball bushing
- XL - For use with XR bearing (Carbon Steel)

Optional Features:

- PD - Predrilled
- CPPE - Chrome Plated Plain Ends
- DC - Deep Case

*Trademark of Thomson Industries, Inc. Thomson Industries, Inc. is registered in the U.S. Patent and Trademark Office and in other countries.

Thomson Product Line Overview

Standard Support Rail Size and Availability Chart

Type	SR	SR-PD	SRA	SRA-SS	SRA-TU	LSR	LSR-PD	LSRA	LSRA-CR	XSR	XSRA
Description	Aluminum Support Rail	Aluminum Support Rail with Predrilled Holes	Aluminum Support Rail Carbon Steel Shaft	Aluminum Support Rail Assembly 440C SS Shaft	Aluminum Support Rail 51200 Tubular Shaft	Steel Lower Support Rail	Steel Lower Support Rail with Predrilled Holes	Steel Lower Support Rail Assembly Carbon Steel Shaft	Corrosion Resistant Steel Lower Support Rail Assembly 440C SS Shaft	Extra Rigid Cast Steel Support Rail	Extra Rigid Cast Steel Support Rail Assembly
1/2"	•	•	•	•		•	•				
5/8"	•	•	•	•		•	•	•	•		
3/4"	•	•	•	•	•	•	•	•	•		
1"	•	•	•	•	•	•	•	•	•		
1 1/4"	•	•	•	•		•	•	•	•		
1 1/2"	•	•	•	•	•	•	•	•	•		
2"	•	•	•	•	•	•	•			•	•
2 1/2"						•	•				
3"						•	•			•	•
4"						•	•				
Catalog Page	188	188	189	189	189	188	188	189	189	188	189

Standard Support Rail Assembly Size and Availability Chart

Type	SRM	SRM T1	SRM T2	SRAM T1	SRAM T2	LSRM	LSRM T1	LSRM T2	LSRA M	LSRA M CR
Description		Steel Lower Support Rail Assembly Carbon Steel Shaft T1 Hole Pattern	Steel Lower Support Rail with Predrilled Holes T2 Hole Pattern	Aluminum Support Rail Assembly with Predrilled Holes T1 Hole Pattern	Aluminum Support Rail Assembly with Predrilled Holes T2 Hole Pattern	Steel Lower Support Rail	Steel Lower Support Rail with Predrilled Holes T1 Hole Pattern	Steel Lower Support Rail with Predrilled Holes T2 Hole Pattern	Steel Lower Support Rail Assembly Carbon Steel Shaft	Corrosion Resistant Steel
12mm	•	•	•	•	•	•	•	•	•	•
16mm	•	•	•	•	•	•	•	•	•	•
20mm	•	•	•	•	•	• ¹	• ¹	• ¹	• ¹	• ¹
25mm	•	•	•	•	•	•	•	•	•	•
30mm	•	•	•	•	•	•	•	•	•	•
40mm	•	•	•	•	•	• ¹	• ¹	• ¹	• ¹	• ¹
Catalog Page	198	198	198	198	198	198	198	198	198	198

Standard Support Block Size and Availability Chart

Type	ASB	FSB	SB	WM	Type	ASBM	SBM
Description	Aluminum Support Block	Flanged Aluminum Support Block	Steel Support Block	Waymount Support	Description	Aluminum Support Block	Steel Support Block
1/4"	•		•		8mm	•	•
3/8"	•		•		12mm	•	•
1/2"	•	•	•	•	16mm	•	•
5/8"			•		20mm	•	•
3/4"	•	•	•		25mm	•	•
1"	•	•	•	•	30mm	•	•
1 1/4"		•	•		40mm	•	•
1 1/2"	•		•	•			
2"				•	Catalog Page	199	199
3"				•			
4"				•			
Catalog Page	191	192	191	192			

¹ Not all sizes are stocked, minimum order quantities may apply.

*Trademark of Thomson Industries, Inc. Thomson Industries, Inc. is registered in the U.S. Patent and Trademark Office and in other countries.

Thomson Product Line Overview

RoundRail Linear Guides are the non-driven building blocks for linear slide tables. They offer the end user flexibility to fit specific envelopes by allowing customized separations between shafts and between Bearings on shafts to produce higher moment capacity. When combined with ballscrew assemblies, they become a driven slide table.

Because RoundRail Linear Guides are offered in a wide range of sizes, bearing types, and mounting configurations, they are typically selected by the qualitative attributes that are most appropriate for a given application (i.e. environmental considerations, mounting footprint). For this reason, we are providing the following selection chart and selection criteria for consideration:

Systems Quick Reference Guide

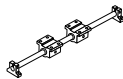
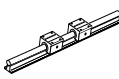
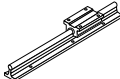
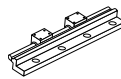
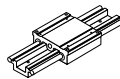
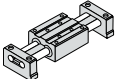
Application Criteria		End Support	Continuous Support	FluoroNyliner	Side Mounted	Dual Shaft Rail	Twin Shaft Web
							
		1BA / 1NA	1 CA / 1PA	1 VA	1 DA	2DA	2CA
High Loads			•	•			
Equivalent Loads in All Directions		•				•	
Ultra Compactness		•					•
Extreme Smoothness		•	•		•		•
End Supported		•				•	•
Single Rail							•
Harsh Environment				•			
Low Cost Installation (multiple rail)		•	•	•	•		
Complete Axis Solution							•
Available Sizes:	Inch	4 thru 24	8 thru 24	8 thru 24	•	•	
	Metric	8 thru 40	12 thru 40		8 thru 16	8 thru 16	8 thru 16
Page Number		237/239	242/244	247	250	253	256

Linear Guide Selection Criteria

- Load/Life
- Travel Accuracy
- Rigidity
- Smoothness of Travel
- Speed & Acceleration
- Envelope
- Environment
- Cost of Product
- Cost of Installation
- Cost of Replacement

Application Examples

- Machine Tools
- Packaging Machinery
- Automotive Assembly Equipment
- Semiconductor Equipment
- Medical Equipment
- Food Processing Equipment

*Trademark of Thomson Industries, Inc. Thomson Industries, Inc. is registered in the U.S. Patent and Trademark Office and in other countries.

Round or Square?

Thomson Product Line Overview

Let Thomson help you choose the right rail type and carriage.

Since the introduction of the square, or profile rail, linear guide in the 1970's, the design engineer has been faced with the pivotal question: **round or square?**

While square rails initially cost many times more than round technology due to the extensive grinding requirements inherent in the design, new manufacturing techniques and economies of scale have allowed square rails to compete effectively in a broader application space. Once subjugated to the realm of machine tools, profile rails can now be found in many of the same applications that were once only supported by round rail. However, ball bushing guides remain popular due to some intrinsically unique and often advantageous characteristics that lend themselves to specific applications.

In order to apply the correct type of linear guide in a particular application, the design engineer must consider the advantages and capabilities of each. The cost of selecting the wrong technology can result in a lot of additional design complexity, poor function and cost in the overall assembly. As a first cut it is useful to have a general understanding of the strengths and weaknesses of each type of product.

The table below outlines typical performance characteristics of round and profile rails and where one is superior.





Attribute	Round	Square
Performance		
Load Capacity	medium	high
Accuracy	medium	medium - high
Stiffness	medium	high
Available preload	yes (light)	yes (light - heavy)
Single guide supports moments	no	yes
Same load capacity in all directions	no	available (typical)
Seal effectiveness	high	medium
Smoothness	high	medium - high
Drag	low	medium - high
Total Cost of Ownership		
Ease of installation	high	medium
Required precision of mating component	low	high
Self aligning	yes	no
Life Expectancy	medium	high
Material Cost	low	medium
Design Flexibility		
Ability to span gaps	yes	no
Can be used as structural frame member	yes	no
Ability to use as single rail & guide	no	yes¹
Compactness (load capacity to size)	medium	high
Ease of modification/Interchangeability	high	low
Rail Mounting		
Available end support mounting	yes (preferred)	no
Available continuous support mounting	yes	yes (preferred)
Available mounting from top of rail	yes	yes (preferred)
Available mounting from bottom of rail	yes	yes

This catalog includes detailed ordering information for RoundRail Linear Guides. Refer to the separate Thomson Profile Rail catalog for detailed square rail linear guides information.

1. Depending on the application. Most square rail applications use dual rails.

*Trademark of Thomson Industries, Inc. Thomson Industries, Inc. is registered in the U.S. Patent and Trademark Office and in other countries.

RoundRail Bearings

	Description	Product Overview	Comments
<p>Plain Contact</p> 	<p>Provides self-lubricating, low friction, smooth motion for high load conditions.</p>	<ul style="list-style-type: none"> • PTFE tape is bonded to the ID of an aluminum housing. • Suitable for wash-down & food applications. • Can withstand high vibration & shock loads. • Extremely smooth running; does not require an overly smooth surface to run on. • Compensated • Sizes ¼" – 2", closed, open, adjustable 	
<p>Steel Sleeve (A)</p> 	<p>The steel sleeve anti-friction recirculating ball bushing provides rigid low drag movement – ~100x lower drag coefficient than a plain contact bearing.</p>	<ul style="list-style-type: none"> • A-Bearings – all steel (operates up to 450°F/232°C) with 3 grades of precision available (A, XA, B); sizes ¼" – 4", closed, open, adjustable. • MAM (MultiTrac A Metric) – twin track configuration, sleeve and a Delrin retainer; size 8 – 40mm, closed open, adjustable. • INST BRGS – precision miniature stainless steel (corrosion resistant) - sizes: 1/8" – 1/4". • Die Sets – designed specifically for die movement applications; size: 1" – 2". 	<ul style="list-style-type: none"> • The patented MAM is the smoothest and highest load capacity A-type bearing in the market. • Corrosion resistant versions available.
<p>Super</p> 	<p>The self-aligning 52100 bearing plate has a ball conforming groove that, with the Delrin sleeve and retainer provide high load capacity smooth motion.</p>	<ul style="list-style-type: none"> • The ball conforming groove enables the Super bearing to provide 3x the load capacity or 27X the L10 travel life of a conventional steel ball bushing bearing . • Sizes ¼" – 2", 5 – 50mm, open/closed • Ball Groove, Cartridge, Out- Rigger, Segment Bearings, XR's 	<ul style="list-style-type: none"> • Additional seal option on outside of bearing and on the pillow blocks offers sealing preferred over competitors by our customers. • Thomson has the largest installed base in North America. • Competitors have modeled their products after Thomson.
<p>Super Smart</p> 	<p>Truly self-aligning twin track linear bearing.</p> <p>The 52100 Steel plate pitches, rocks and rolls on a precision hardened steel band to provide universal type alignment capability.</p>	<ul style="list-style-type: none"> • 3 industry standards • Imperial Sizes ½" – 1 1/2 " • ISO Metric 16 – 40mm • JIS Metric 16 – 40mm • SS6U, E, J's available 16 – 40mm • Closed and Open 	<ul style="list-style-type: none"> • This patented product provides smooth, quiet, low drag linear movement at 6x the load capacity or 216 x the L10 travel life of a conventional steel linear ball bushing bearing. • Also available in a low cost 6 track version. • Its unique design with the steel band enables the bearing to preserve it's ID fit-up and self-aligning capability over extended use.

*Trademark of Thomson Industries, Inc. Thomson Industries, Inc. is registered in the U.S. Patent and Trademark Office and in other countries.

60 Case Shafting

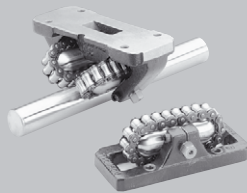
	Description	Product Overview	Comments
Specialty Bearings 	There are a multitude of specialty Bearings that can be configured or developed to suit almost any customers needs.	<ul style="list-style-type: none"> Round Way - all steel construction and a chain that connects the rolling elements; Sizes 1/2" – 4". NB (nylon ball) Bearings, Smart MultiTracs, Cartridge Bearings, etc. 	<ul style="list-style-type: none"> Highest load rating of the linear bearings. The ratings are based on a longer travel than other linear Bearings use. The chain enables the bearing to withstand very high speeds and accelerations. Temperatures up to 450°F/232°C. Suitable for extremely harsh environments.

Accessories/Options

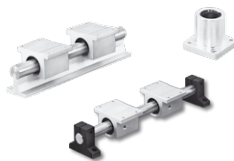





The host of accessories and options associated with RoundRail Bearings are multitudinous.

Steel Pillow Blocks, Aluminum Pillow Blocks, Singles, Twins, Closed, Opens, Adjustable, Flanged Pillow Blocks, Self-Aligning PB's, XPB's, XPBO's, RSPB's, RSPBO's, CR's, wipers, seals, DD's, stainless steel options, resilient mounts, Lube Fittings, etc.

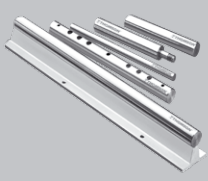
Largest variety in the industry of customized offerings, accessories, and options that allow for new and broader uses of Bearings in unusual, harsh, and state-of-the-art applications.

60 Case Shafting

	Description	Product Overview	Comments
	60 Case Shafting	<ul style="list-style-type: none"> AISI 1566 Sizes: 3/16" – 4" and 5– 80mm Bolt down from the top Smart Rail 	<i>(applies to 60 Case Shafting, 440C & 300 Stainless Steel Shafting, 60 Case Tubular Shafting and their Accessories/Options)</i> <ul style="list-style-type: none"> High grade steel used for standard product – 1566 vs. competitor's 1060. Coil-to-bar mfg. technology permits sourcing of hot rolled material, lower costs, sourcing flexibility, high straightness levels, and controlled sizing prior to induction hardening. Precisely controlled case hardening to max. hardness (>62 HRC at highest bearing stress depth & Hertzian stress levels).
	440C & 316 Stainless Steel Shafting	<ul style="list-style-type: none"> AISI 440C Sizes: 1/8" – 2 1/2" and 5 - 60mm AISI 316 Sizes: 3/8" – 2" 	<ul style="list-style-type: none"> Low stress precision grinding techniques to produce: - Dia. tolerance control (<0.0002" - classes D & N) - Roundness variation (<0.000080") - Taper var. on 17" L or 1/2" dia. tolerance (<0.0002") - Surface finish (< 6 Ra) defect free surface - Straightness (capability to < 0.0005" / foot)
	60 Case Tubular Shafting	<ul style="list-style-type: none"> AISI 52100 Tubular Size: 3/4" – 4" 	<ul style="list-style-type: none"> Value added machining capabilities of hard turning, radial drill and tapping, milling; journal machining to 0.0002" max. dia. variation and <0.001" concentricity variation. Random lengths, cut to length, and special machined forms available. Engineered assembly solutions -- SR(M) and LSR (M). Standard product available for next day shipping.
	Ultra Light Aluminum Shafting	<ul style="list-style-type: none"> 6061-T6 aluminum with HRC 70 hard anodize finish Sizes 1/4" - 1" 	<ul style="list-style-type: none"> Value added machining capabilities of hard turning, radial drill and tapping, milling; journal machining to 0.0002" max. dia. variation and <0.001" concentricity variation. Random lengths, cut to length, and special machined forms available. Engineered assembly solutions -- SR(M) and LSR (M). Standard product available for next day shipping.
	Accessories/Options	<ul style="list-style-type: none"> PD, SM, classes (S, L, D, N, XL, M, MN, G), deep case, SB, ASB, ASBM, FSB, Way Mounts, SR, SRA, LSR, LSRA, SRM, LSRM, XSR's, platings, coatings, metric, etc. 	Includes all of above

- Largest product breadth in the industry.
- Most technically advanced product offering that conforms to extremely stringent tolerance specifications.
- 60+ years of manufacturing experience.
- Thomson brand name known for consistent and unparalleled quality.

*Trademark of Thomson Industries, Inc. Thomson Industries, Inc. is registered in the U.S. Patent and Trademark Office and in other countries.

Profile Rail

Profile Rail

Overview of Thomson Profile RoundRail Linear Guides

Since the invention of the linear anti-friction Ball Bushing bearing by Thomson over 50 years ago, the Thomson precision linear products have meant high quality, innovative products. Today, Thomson continues producing and developing these high quality, innovative products. The Thomson Profile Rail assortment consists of the Next Generation Profile Rail “500 Series” Ball and Roller Linear Guides, compact miniature “MicroGuide,™” lightweight “T-Series,” and AccuMini. This page is a quick overview of Thomson Profile Rail, complete details of which can be found in the Thomson Profile Rail Catalog.

	Description	Product Overview	Comments
 <p>500 Series Ball</p>	<p>Highly configurable standard ball guidance system designed per DIN standard 645 to support a load and allow low friction, precise linear translation of that load.</p>	<ul style="list-style-type: none"> • High rigidity with high dynamic and static load capacities. • 7 carriage designs with multiple accuracies and preloads available. • Replaces Thomson AccuGlide. • Sizes 15, 20, 25, 30, 35, 40mm 	<p><i>(Applies to 500 Series Ball and 500 Series Roller)</i></p> <ul style="list-style-type: none"> • Standard 6m lengths are longest offered in the industry - minimizes need for butt joints. • “Lube for life” lubrication block allows for low maintenance and eliminates need for lube lines.
 <p>500 Series Roller</p>	<p>Highly configurable standard roller guidance system designed per DIN standard 645 to support a load and allow low friction, precise linear translation of that load - larger contact surface of roller elements (versus ball) results in greater load capacity.</p>	<ul style="list-style-type: none"> • Extremely high rigidity and dynamic/static load capacities • 4 carriage designs with multiple accuracies and preloads • Replaces Thomson AccuMax • Sizes 25, 35, 45, 55, 65mm 	<ul style="list-style-type: none"> • Modular accessories allow for on-site upgrade without having to remove carriages from rail. • Double back configuration provides high roll moment resistance - removes the need for dual or wide rails in some applications.
 <p>400 Series Ball</p>	<p>The 400 Series Profile Rail Linear Guide is the newest addition to the Thomson Linear Guide product line. This product is a transport grade solution with cost-sensitive applications in mind.</p>	<ul style="list-style-type: none"> • Drop-in replacement with industry-standard envelope and hole patterns. • 7 carriage designs with multiple accuracies, preloads & options. • Sizes 15, 20, 25, 30, 35 & 45mm 	<ul style="list-style-type: none"> • Modular accessories for on-site upgrades. • Double-faced ball track bearing arrangements provide compliance during installation as well as equal load carrying capacity in all directions. • Caged and non-caged carriages available.
 <p>AccuMini</p>	<p>Low profile design that provides high roll moment capacity in a smaller envelope.</p>	<ul style="list-style-type: none"> • Sizes 10, 15, 20mm 	<ul style="list-style-type: none"> • Gothic arch ball design allows for quiet, low friction movement at high speeds. • Full-length integral wiper protects bearing from contaminants.
 <p>MicroGuide</p>	<p>Stainless steel miniature guidance system that provides corrosion resistance for clean room and wash-down applications.</p>	<ul style="list-style-type: none"> • 440C SS construction • High precision accuracy (up to ±0.010mm) • Standard and wide carriage styles • Sizes 5, 7, 9, 12, 15mm 	<ul style="list-style-type: none"> • Ideal for small design envelope requirements in semiconductor processing equipment and medical diagnostic equipment. • Quiet operation
 <p>T-Series</p>	<p>Aluminum guidance system utilizing hardened steel inserts in carriages and rails that, in turn, provide a low-weight solution for critical, high performance applications.</p>	<ul style="list-style-type: none"> • U-channel design accommodates misalignment from machine bases or installation errors. • Sizes 20, 25, 35mm 	<ul style="list-style-type: none"> • An excellent high precision guide alternative for low-weight applications. • No special tools or gauges to align rail, allowing for low cost of installation.

*Trademark of Thomson Industries, Inc. Thomson Industries, Inc. is registered in the U.S. Patent and Trademark Office and in other countries.

Ball Bushing Bearings Overview

Linear Bearings Overview



Linear Bearings* 15 - 164

Inch Ball Bushing Bearings 15 - 96

Lube for Life.....22

Super Smart Ball Bushing Bearings 23 - 29

Super Smart Ball Bushing Pillow Blocks 30 - 45

Super Ball Bushing Bearings 46 - 54

Super Ball Bushing Pillow Blocks 55 - 68

Precision Steel Ball Bushing Bearings..... 69 - 77

Precision Steel Ball Bushing Pillow Blocks.. 78 - 89

XR Extra Rigid Ball Bushing Bearings..... 90 - 93

XR Extra Rigid Ball Bushing Pillow Blocks.... 94 - 96

Specialty Bearings 97 - 124

RoundWay* Linear Roller Bearings 95 - 104

FluoroNyliner* Bushing Bearings..... 105 - 118

Accessories 119 - 124

Metric Ball Bushing Bearings..... 125 - 169

General Product Overview 125 - 126

Super Smart Ball Bushing Bearings 127 - 135

Super Smart Ball Bushing Pillow Blocks .. 136 - 147

Super Metric Ball Bushing Bearings 148 - 155

Super Metric Ball Bushing Pillow Blocks . 156 - 159

MultiTrac* Ball Bushing Bearings..... 155 - 166

Accessories 167 - 169

Ball Bushing Bearings Overview

Thomson Linear Motion Components

The RoundRail Advantage...



Super Smart Ball Bushing Bearings

Thomson Super Smart Ball Bushing Bearings represent a major advancement for Linear bearing technology, worldwide.

This patented self-aligning linear bearing provides twice the load carrying capacity or eight times the travel life of the industry standard Thomson Super Ball Bushing bearing. This dramatic increase in load capacity allows the use of less expensive drive motors, linkages, gears and ball screws. The unique Super Smart design allows the bearing to maintain its diametrical fit up when installed in housings that are soft or slightly out-of-round. Super Smart Bearings utilize the RoundRail Advantage that eliminates the need for derating factors commonly used with linear guides. The Bearings are called "Smart" because their universally self-aligning, double-track design incorporates engineering concepts that literally render old style conventional Bearings obsolete. Available in inch and metric sizes from over 1800 distributors worldwide. (See Page 23)



Super Smart Ball Bushing Pillow Blocks

Thomson Super Smart Ball Bushing Pillow Blocks available in closed, adjustable and open styles in both single and twin versions.

To minimize installation time and cost, the Super Smart Ball Bushing bearing can be ordered factory-installed in an industry standard single or twin pillow block. The closed type pillow block is used in end supported applications for spanning or bridging a gap. The open style is used in continuously supported applications when maximum rigidity and stiffness is required. Each Super Smart Pillow block is complete with integral double acting seals which keep out contaminants, retain lubrication and maximize bearing life. Since each Pillow Block is dimensionally interchangeable with the industry standard Thomson Super Ball Bushing Pillow Block, system performance improvements can be realized immediately. All Pillow Blocks are available and in stock from over 1800 authorized distributors worldwide. (See Page 30)



Super Ball Bushing Bearings

Industry standard self-aligning Super Ball Bushing Bearings available in twenty three sizes and configurations.

Super Ball Bushing Bearings offer three times the load capacity or twenty seven times the life of conventional linear Bearings. Industry standard self-aligning Super Ball Bushing Bearings ease installation and minimize wear from minor bore misalignment. Super Ball Bushing Bearings can achieve speeds up to 10 ft/s and accelerations up to 450 ft/s² without the derating factors commonly found in linear guide products. With a coefficient of friction as low as .001, Super Ball Bushing Bearings provide a quick easy replacement for high friction plain Bearings. The wear-resistant, engineered-polymer retainers and outer sleeves reduce inertia and noise in critical, high speed applications. Super Ball Bushing Bearings are available in both open and closed versions from over 1800 distributors worldwide. (See Page 46)

Ball Bushing Bearings Overview

... **The RoundRail Advantage** - The inherent ability of a RoundRail Ball Bushing bearing system to accommodate torsional misalignment (caused by inaccuracies in carriage or base machining or by machine deflection) with little increase in stress to the bearing components.



Super Ball Bushing Bearing Pillow Blocks

Available in closed, adjustable and open styles in both single and twin versions.

Thomson Super Ball Bushing Bearings are also available factory installed in single or twin pillow blocks. Super Ball Bushing bearing pillow blocks are provided with integral, double acting seals that keep out contaminants and retain lubrication, maximizing system performance and life. Twin versions provide up to twice the load capacity or eight times the life of single versions, allowing the use of smaller and less expensive drives, motors and ball screws. When replacing v-ways and flat-ways, the Super Pillow Block's low coefficient of friction reduces power consumption and provides important design economies. In stock and available in sizes from 1/4 to 2 inch from over 1800 distributors worldwide. (See Page 55)



Precision Steel Ball Bushing Bearing Products

Rigid, Precision Steel Ball Bushing Bearing design eliminates binding and chatter found in high friction plain Bearings.

Precision Steel Ball Bushing Bearings are available in an open version for continuously supported applications and a closed version for end supported applications. Extra precision and adjustable versions are available for end supported applications requiring higher precision and repeatability. Precision Steel Ball Bushing bearing products are also available factory installed in a self-aligning, malleable iron pillow block minimizing installation time and cost. The all-steel design makes the Precision Steel Ball Bushing bearing product line perfect for replacing plain Bearings in high temperature applications. Available in 72 sizes and configurations from over 1800 distributors worldwide. Now available in 440 stainless steel, ideal for harsh and high temperature environments. (See Page 69)



Miniature Instrument Ball Bushing Bearings

High Accuracy and Compactness for Instrumentation Level Applications.

The accuracy level and compact size make the Instrument Ball Bushing bearing ideal for small mechanisms or devices that require high repeatability and responsiveness. When replacing high friction plain Bearings, the Instrument Ball Bushing Bearings' constant low coefficient of friction eliminates stick-slip and provides smooth linear performance. Each Instrument Ball Bushing bearing can be provided with a matched 60 Case LinearRace shafting for minimum fit-up, optimizing system performance and accuracy. In stock and available in sizes 1/8, 3/16 and 1/4 inch from over 1800 distributors, worldwide. (See Page 80)

Ball Bushing Bearings Overview

Thomson Linear Motion Components

The RoundRail Advantage...



Die Set Ball Bushing Bearings

Available in two accuracy classes and suitable for a variety of industrial applications.

Thomson Die Set Ball Bushing Bearings are designed to fit the mounting holes of the punch holder in standard dies. When replacing high friction plain Bearings in standard dies, the result is less machine downtime and increased efficiency. With steady state speeds up to 10 ft/s, the Die Set bearing will provide faster cycle times, with improvements in production rates realized immediately. Matched precision ground 60 Case LinearRace allows for a close fit-up between the shaft and the LinearRace shafting and bearing providing critical die alignment. When normal machine service requires bearing replacement, the Die Set bearing can be removed by simply unbolting the toe clamps. Available in 1, 1 1/4, 1 1/2 and 2 inch sizes from over 1800 distributors worldwide. (See Page 82)

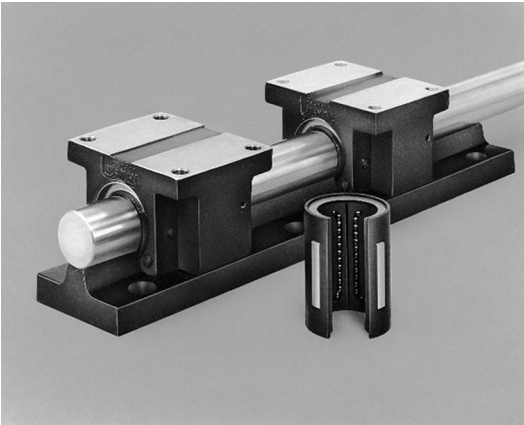

XR Ball Bushing Bearing Products

High load capacity and rigidity combined with the RoundRail Advantage.

The XR Ball Bushing bearing provides five times the load capacity or 125 times the life of conventional linear Bearings. This increase in bearing performance significantly reduces downtime and maintenance, while increasing machine reliability. When replacing v-ways and flat-ways, XR Ball Bushing Bearings allow travel speeds up to 5 ft/s and accelerations up to 225 ft/s² without a sharp increase in power consumption. XR Ball Bushing Bearings also provide three times the rigidity of conventional Ball Bushing Bearings reducing deflection in critical machining applications. Pillow Blocks are available with factory installed XR Ball Bushing Bearings and integral seals. 60 Case LinearRace shafting available pre-mounted on standard extra rigid LinearRace support rails. Available in 2, 3 and 4 inch sizes from over 1800 distributors worldwide. (See Page 90)



RoundWay Linear Roller Bearings

Low friction roller Bearings with up to 20 times the load capacity of conventional linear Bearings.

These patented, self-aligning linear roller Bearings have over 20 times the load capacity of a conventional linear ball bearing. This dramatic increase in bearing load capacity allows designers to optimize system compactness and minimize hardware costs. Combining the self-aligning feature with the RoundRail Advantage minimizes installation time and assures trouble-free operation. RoundWay Bearings can achieve operating speeds up to 10 ft/s without the derating factors commonly seen with linear guides. When normal machine maintenance is required, RoundWay Bearings can be quickly and cost-effectively replaced, without scrapping the entire system, a major problem when servicing some linear guides. RoundWay Bearings are available from over 1800 authorized distributors worldwide. (See Page 97)

Thomson Linear Motion Components

The RoundRail Advantage...



FluoroNyliner Bushing Bearings

Thomson FluoroNyliner Bushing Bearings offer:

- High performance in contaminated, washdown, or submerged environments
- Proprietary, self-lubricating, composite bearing liner TEP 950
- Low friction, ideally suited for linear and rotary motion
- Precision machined aluminum sleeve
- Excellent performance in high vibration and mechanical shock applications
- Corrosion resistance
- Product availability in industry standard sizes from 0.25" to 2.00"
- Eight bearing configurations, include closed, open, self-aligning, precision and compensated IDs
- Load capacities up to 14,000 lb_f
- Integral seals
- Closed, Open, and Flanged Pillow Blocks available in single or twin versions
- Available from over 1800 distributors worldwide

Thomson Product Line Overview

Ball Bushing Bearings

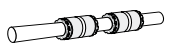
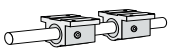
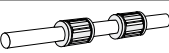
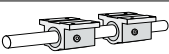
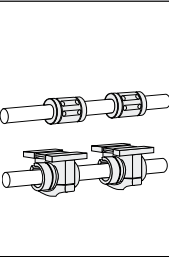
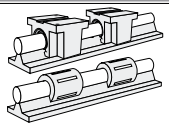
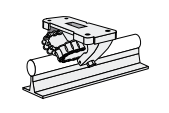
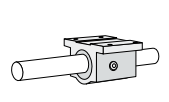
		Page Number	Imperial (Inch)							
			1/8	3/16	1/4	3/8	1/2	5/8	3/4	1
Super Smart										
	Ball Bushing Bearings corrosion resistant option available	inch: 23 metric: 127					○	○	○	○
	Ball Bushing Pillow Blocks corrosion resistant option available	inch: 30 metric: 136					○ STA	○ STA	○ STA	○ STA
Super										
	Ball Bushing Bearings corrosion resistant option available	inch: 46 & 59 metric: 153		□	□	□	○	○	○	○
	Ball Bushing Pillow Blocks corrosion resistant option available	inch: 55 & 64 metric: 156			□ STA	□ STA	○ STA	○ STA	○ STA	○ STA
Precision Bearings										
	A-Bearings and Pillow Blocks available in stainless steel	76			□	□ SA	○ SA	○ SA	○ SA	○ SA
	MultiTrac available in stainless steel	148								
	Instrument	80	□	□	□					
	Die Set	82								□
XR Extra Rigid										
	Ball Bushing Bearings and Pillow Blocks	90								
Specialty										
	Cartridge bearing	53			□ ST	□ ST	□ ST			
	RoundWay	97					□			□
FluoroNyliner										
	Bushing bearings	105				○	○	○	○	○
	Pillow Blocks	110				○ STF	○ STF	○ STF	○ STF	○ STF

- Closed Type
- Open Type
- Closed and Open Type
- S Single Configuration
- T Twin Configuration
- A Adjustable Configuration
- F Flanged Configuration

Thomson Product Line Overview

Imperial (Inch)						Metric (mm)										
1 1/4	1 1/2	2	2 1/2	3	4	5	8	10	12	16	20	25	30	35	40	50
⊙	⊙						□		⊙	⊙	⊙	⊙	⊙		⊙	
⊙	⊙						□		⊙	⊙	⊙	⊙	⊙		⊙	
STA	STA						STA		STA	STA	STA	STA	STA		STA	
⊙	⊙	⊙					□		⊙	⊙	⊙	⊙	⊙		⊙	⊙
⊙	⊙	⊙					□		⊙	⊙	⊙	⊙	⊙		⊙	⊙
STA	STA	STA					STA		STA	STA	STA	STA	STA		STA	STA
⊙	⊙	⊙	⊙	⊙	⊙											
SA	SA	SA	SA	SA	SA											
							□		⊙	⊙	⊙	⊙	⊙		⊙	
							SA		SA	SA	SA	SA	SA		SA	
□	□	□														
		⊙		⊙												
⊙	⊙	⊙														
⊙	⊙	⊙														
STF	STF	STF														

Lube for Life

New Self Lubricating Linear Bearing Pillow Blocks



Thomson Lube for Life pillow blocks provide continuous bearing lubrication and enhanced protection for a broad range of applications. Self-lubricating cartridges are pressed into each end of the pillow block housing, and the linear bearing is lubricated initially with EP2 grease. The Lube for Life polymer is under constant pressure against the 60 Case shafting, ensuring a film of lubricant between the ball bearings and the inner race.

Features and Benefits

- Maintenance-free operation
- Eliminates need for expensive lubrication systems
- Available as an option for Thomson Pillow Block types:
 - Super and Super Smart Ball Bushing bearing
 - Open and Closed
 - Single and Twin
- Available as a retrofit kit for existing non self-lubricating Pillow Block assemblies

Closed Self-Lubricating Pillow Block Assemblies

Nominal LinearRace Diameter	L1	L2 Single	L2 Twin
.500	.23	2.15	3.96
.750	.24	2.55	4.98
1.000	.30	3.42	6.60
1.250	.42	4.47	8.34
1.500	.43	4.86	9.86

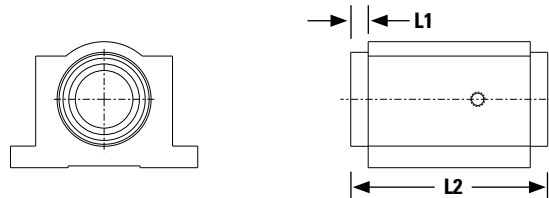

Open Self-Lubricating Pillow Block Assemblies

Nominal LinearRace Diameter	L1	L2 Single	L2 Twin
.500	.31	2.11	4.12
.750	.30	2.49	5.10
1.000	.30	3.24	6.60
1.250	.42	4.21	8.34
1.500	.43	4.60	9.86

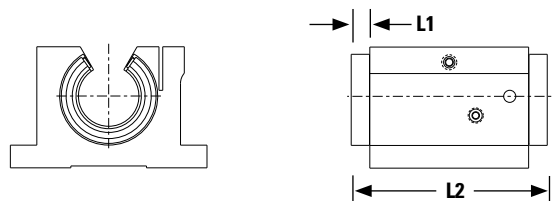

Super Smart Ball Bushing Bearings

Super Smart Ball Bushing Bearing Products

**Thomson Super Smart Ball Bushing Bearing products offer:**

- Up to six times the load capacity or 216 times the travel life of conventional linear bearings.
- Twice the load capacity or eight times the travel life of industry standard Thomson Super Ball Bushing bearings.
- A precision super finished, dual track bearing plate for optimum system smoothness and performance.
- A universal self-alignment feature, that compensates for misalignment of housing bores and 60 Case LinearRace shaft deflection, optimizes load distribution between ball tracks and assures uniform ball loading over the entire length of the bearing plate. Installation time and cost is minimized while bearing performance and life is maximized.
- A technologically advanced design that allows the bearing to maintain its diametrical fit-up when installed in a housing that is slightly out-of-round.
- Longer travel life and minimal machine downtime when replacing conventional linear bearings or the industry standard Super Ball Bushing bearing.
- The RoundRail Advantage combined with universal self-alignment eliminating the need for derating factors commonly required when using linear guides.
- A coefficient of friction as low as .001. This allows the use of smaller less expensive motors, belts, gears and ball screws, when replacing high friction, plain bearings.
- Closed and open configurations.
- Double lip integral wipers that keep out dirt while retaining lubrication. Travel life is maximized.
- Worldwide availability from over 1500 authorized distributors.
- Steady state travel speeds up to 10 ft/s and accelerations to 450 ft/s without the use of derating factors.

Super Smart Ball Bushing Bearings

The new Super Smart Ball Bushing Bearing represents a major advancement in linear bearing technology worldwide. The Super Smart Ball Bushing Bearing offers twice the load capacity or eight times the travel life of the industry standard Thomson Super Ball Bushing bearing. An enormous technological breakthrough, considering the Super Ball Bushing bearing already offers three times the load capacity or twenty-seven times the travel life of conventional linear bearings.

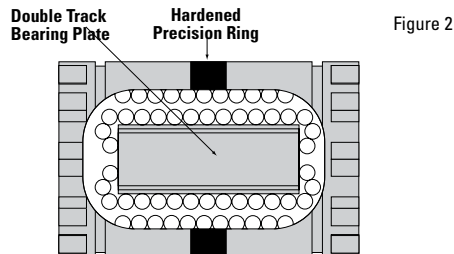
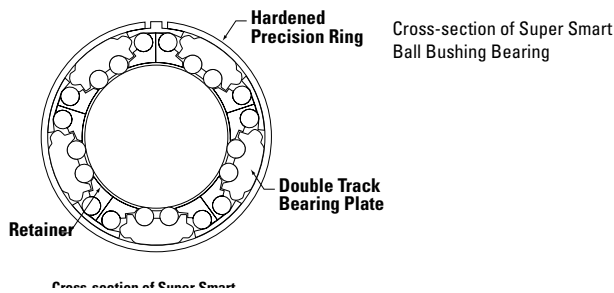

Technologically Advanced Design

The load carrying component of the Super Smart Ball Bushing Bearing is the combination of four hardened bearing quality steel components (Figures 1 & 2).

The first component is the steel outer ring, which allows the bearing to maintain its diametrical fit-up even when installed in a housing that is slightly out-of-round. The unique ring design also allows for bearing adjustment and the removal of diametrical clearance. The second component is the precision super finished double track bearing plate that provides twice the load capacity and features universal self-alignment.

The third component is the rolling element. Each Super Smart Ball Bushing Bearing utilizes precision ground balls manufactured to the highest quality standards for roundness and sphericity. The result is maximum load capacity, travel life and performance.

The last component is the 60 Case LinearRace shaft that acts as the inner race to the Super Smart Ball Bushing Bearing. Each 60 Case LinearRace shaft is manufactured to the highest quality standards for roundness, straightness, surface finish and hardness. Roundness is held under eighty millionths of an inch; straightness to .002 inches per foot; surface finish under twelve microinch and hardness between 60-65 HRC. The combination of inner and outer race or 60 Case LinearRace shaft and Super Smart Ball Bushing Bearing provides the basis for the RoundRail Advantage.

The RoundRail Advantage

The RoundRail Advantage is the inherent ability of a Super Smart Ball Bushing Bearing system to accommodate torsional misalignment (caused by inaccuracies in carriage or base machining or by machine deflection) with little increase in stress to bearing components. Installation time and cost are minimized and system performance is maximized.

Super Smart Ball Bushing Bearings

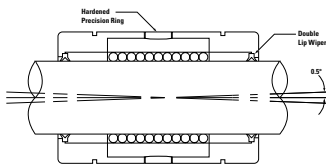

Figure 3

Universal Self-Alignment

The bearing plate of the Super Smart Ball Bushing Bearing is designed with many unique and technologically advanced features. The universal self-alignment feature assures that the Super Smart Ball Bushing Bearing will achieve maximum performance regarding load capacity, travel life, smooth operation and coefficient of friction. The three components that make up universal self-alignment are **Rock**, **Roll** and **Yaw**.

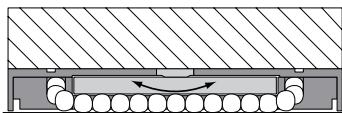

Figure 4

Close-up of hardened precision ring, showing how the bearing plate self-aligns (rocks) about the curved surface of the ring.

Rock

The bearing plate is designed to rock 0.5° about the hardened precision ground outer ring (Figures 3 & 4). This self-aligning feature allows the Super Smart Ball Bushing Bearing to absorb misalignment caused by inaccuracies in housing bore alignment or 60 Case LinearRace shaft deflection. This rocking capability provides smooth entry and exit of the precision balls into and out of the load zone assuring a constant low coefficient of friction. By compensating for misalignment, each bearing ball in the load carrying area is uniformly loaded providing maximum load capacity.

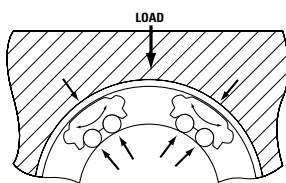

Figure 5

Close-up of double track bearing plates showing how they self-align (roll) to evenly distribute the load on each of their two ball tracks.

Roll

The second key design feature of the Super Smart Ball Bushing Bearing plate is its ability to **Roll**. The bearing plate is designed with the radius of its outer surface smaller than the inside radius of the precision outer ring (Figure 5). This allows the bearing plate to compensate for torsional misalignment and evenly distribute the load on each of its two ball tracks. The roll component assures maximum load capacity and travel life.

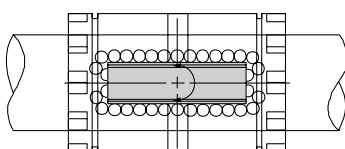

Figure 6

Bearing plates rotate about their center to prevent skewing relative to the 60 Case LinearRace shaft.

Yaw

The shape formed by the **Rock** and **Roll** features allows the Super Smart Ball Bushing Bearing plate to rotate about its center (Figure 6). This allows the Super Smart Ball Bushing Bearing to absorb skew caused by misalignment. The result is a constant low coefficient of friction and maximum bearing performance.

Super Smart Ball Bushing Bearings

The Super Smart Advantage

Advantage: Load Capacity

The Super Smart Ball Bushing Bearing provides twice the load capacity of the industry standard Thomson Super Ball Bushing bearing and six times the load capacity of conventional linear bearings.

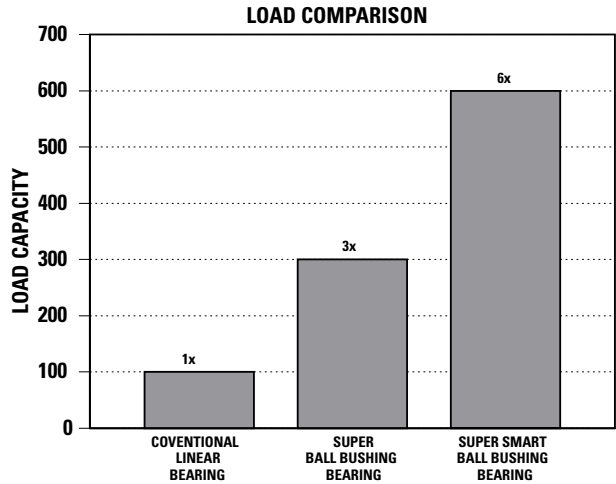

Advantage: Travel Life

The Super Smart Ball Bushing Bearing provides eight times the travel life of the industry standard Thomson Super Ball Bushing bearing and 216 times the travel life of conventional linear bearings.

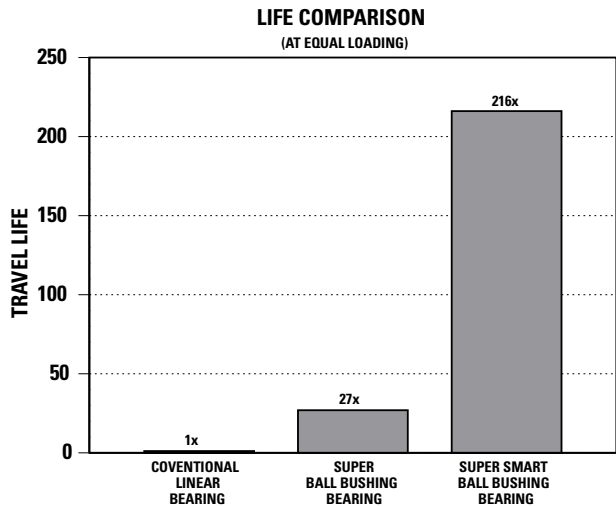

Inch – Super Smart Ball Bushing Bearings

Part Number Description and Specification

Super Smart Ball Bushing Bearings (Closed Type) for End Supported Applications

SSU16WW-CR

Type	Description	Size	Nominal Diameter	Option	Description	Ball Options
SSU	Super Smart Ball Bushing bearings	8	.500	-	No Wipers	Option Description CR Corrosion Resistant NB Nylon Balls NBA Alternating Nylon Balls
		10	.625	W	One Integral Wiper	Lube Options DP Dry Pack LL Lubricated with Thomson Linear Lube
		12	.750	WW	Two Integral Wipers	Other Options RP Roll Pack (no box)
		16	1.000			
		20	1.250			
		24	1.500			

Super Smart Ball Bushing Pillow Blocks (Closed Type) for End Supported Applications

SSUPB16-CR

Type	Description	Size	Nominal Diameter	Ball Options
SSUPB	Super Smart Ball Bushing Pillow Blocks	8	.500	Option Description CR Corrosion Resistant NB Nylon Balls NBA Alternating Nylon Balls
SSUPBA	Super Smart Ball Bushing Adjustable Pillow Blocks	10	.625	Lube Options DP Dry Pack LL Lubricated with Thomson Linear Lube L4L Lube for Life
SSUTWN	Super Smart Ball Bushing Twin Pillow Blocks	12	.750	
SSUTWNA	Super Smart Ball Bushing Twin Adjustable Pillow Blocks	16	1.000	
SSUFB	Super Smart Ball Bushing Flanged Pillow Blocks	20	1.250	
SSUTFB	Super Smart Ball Bushing Flanged Twin Pillow Blocks	24	1.500	

For addition information on bearing options see page 273.

Inch – Super Smart Ball Bushing Bearings

Super Smart Ball Bushing Bearings (Closed Type) for End Supported Applications

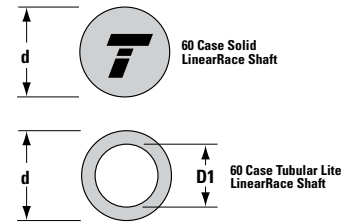
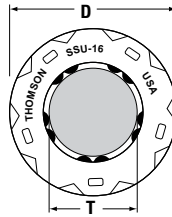
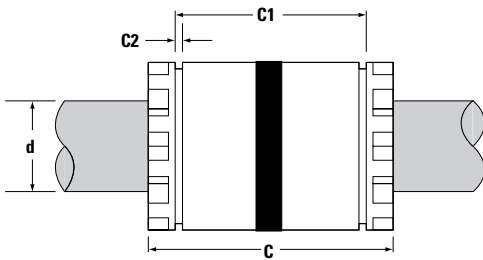
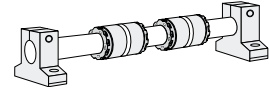

Super Smart Ball Bushing Bearings (Closed Type) and 60 Case LinearRace Shafting (Dimensions in inches)

Part Number ⁽²⁾				Nominal Diameter	Length C	C1	C2 min.	Number of Ball Circuits	Ball Bushing bearing Mass lb	60 Case LinearRace Minimum Depth of Hardness	60 Case Solid LinearRace Mass lb/in	60 Case Tubular Lite LinearRace Mass lb/in	60 Case Tubular Lite LinearRace ID D1
Without Integral Wipers	With one Integral Wiper	With two Integral Wipers	60 Case Linear Race										
SS6U8	SS6U8W	SS6U8WW	1/2 L	.500	1.250/1.230	1.032/1.012	.050	6	.07	.04	.06	–	–
SSU10	SSU10W	SSU10WW	5/8 L	.625	1.500/1.480	1.125/1.095	.055	10	.12	.04	.09	–	–
SSU12	SSU12W	SSU12WW	3/4 L	.750	1.625/1.605	1.285/1.255	.055	10	.16	.06	.13	.08	.46/.41
SSU16	SSU16W	SSU16WW	1 L	1.000	2.250/2.230	1.901/1.871	.068	10	.29	.08	.22	.16	.62/.56
SSU20	SSU20W	SSU20WW	1 1/4 L	1.250	2.625/2.600	2.031/1.991	.068	10	.52	.08	.35	–	–
SSU24	SSU24W	SSU24WW	1 1/2 L	1.500	3.000/2.970	2.442/2.402	.086	10	.99	.08	.50	.33	.93/.84

Part Number ⁽²⁾			Working Bore Diameter T	Recommended Housing Bore		60 Case LinearRace Diameter d	Ball Bushing bearing/60 Case LinearRace Fit Up ‡		Dynamic ⁽¹⁾ Load Capacity lb _f
Without Integral Wipers	With one Integral Wiper	With two Integral Wipers		Fixed D	Adjustable D		Fixed Diameter Housing	Adjustable Diameter Housing (Before Adjustment)	
SS6U8	SS6U8W	SS6U8WW	.5000/.4995	.8755/.8750	.8760/.8750	.4995/.4990	.0015C/.0000	.002C/.0000	265
SSU10	SSU10W	SSU10WW	.6250/.6245	1.1255/1.1250	1.1260/1.1250	.6245/.6240	.0015C/.0000	.002C/.0000	620
SSU12	SSU12W	SSU12WW	.7500/.7495	1.2505/1.2500	1.2510/1.2500	.7495/.7490	.0015C/.0000	.002C/.0000	1130
SSU16	SSU16W	SSU16WW	1.0000/.9995	1.5630/1.5625	1.5635/1.5625	.9995/.9990	.0015C/.0000	.002C/.0000	1900
SSU20	SSU20W	SSU20WW	1.2500/1.2494	2.0008/2.0000	2.0010/2.0000	1.2495/1.2490	.0018C/.0001P	.002C/.0001P	2350
SSU24	SSU24W	SSU24WW	1.5000/1.4994	2.3760/2.3750	2.3760/2.3750	1.4994/1.4989	.0021C/.0000	.0021C/.0000	3880

‡ P = Preload, C = Clearance

(1) The Dynamic Load Capacity is based on a rated travel life of 2 million inches. The actual Dynamic Load Capacity can be affected by the orientation of the bearing or the direction of the applied load. For dynamic load correction factors see polar graphs below.

(2) For part number description and specifications see page 27. For specifications on seals and retaining rings see the Accessories section.

Note: For additional technical information, see the Engineering section beginning on page 262.

Inch – Super Smart Ball Bushing Bearings

Load/Life Graph

(Lines indicate limiting load for given Ball Bushing bearing)

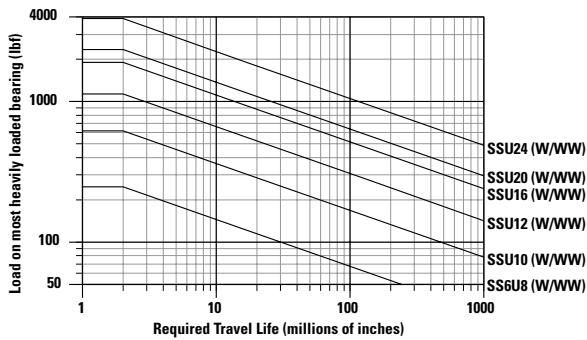

Determining Ball Bushing bearing Size

To determine the proper Ball Bushing bearing size enter the chart with the maximum load of the most heavily loaded bearing and the required travel life. Mark where the two lines intersect. All Ball Bushing bearing sizes that pass through or above and to the right of this point may be suitable for this application.

Note: For the purpose of using this chart.

Load on most heavily loaded bearing = maximum applied load/ K_0 .

Where K_0 can be determined from the Polar Graph to the right.

Polar Graphs

The actual Dynamic Load Capacity of a Ball Bushing bearing is determined by the orientation of the bearing or direction of the applied load. The load Correction Factor K_0 is found by knowing the direction of the applied load relative to the orientation of the bearings ball tracks and referring to the polar graph. To determine the actual Dynamic Load Capacity, multiply the proper correction factor by the Dynamic Load Capacity listed in the product table on the previous page.

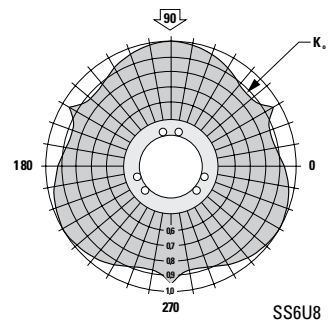
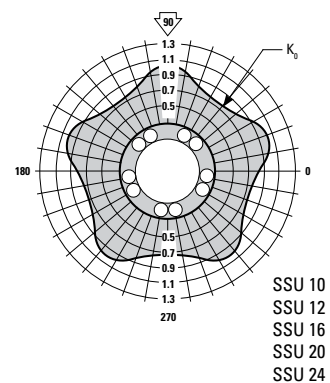

Inch – Super Smart Ball Bushing Bearings

Super Smart Ball Bushing Pillow Blocks (Closed and Adjustable Type) for End Supported Applications

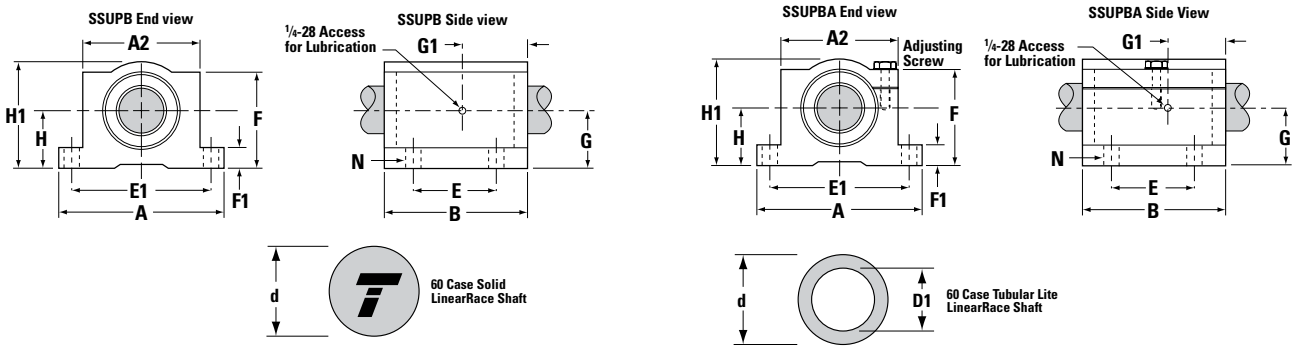
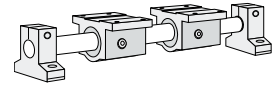

Super Smart Ball Bushing Pillow Blocks (Closed & Adjustable Types, seal at both ends) and LinearRace (Dim. in inches)

Part Number ⁽²⁾		60 Case LinearRace	Nominal Diameter	H ±.003	H1	60 Case LinearRace Diameter d	60 Case LinearRace Minimum Depth of Hardness	60 Case Solid LinearRace Mass lb/in	60 Case Tubular Lite LinearRace Mass lb/in	60 Case Tubular Lite LinearRace ID D1
Fixed	Adjustable									
SS6UPB8	SS6UPBA8	1/2 L	.500	.687	1.25	.4995/.4990	.04	.06	–	–
SSUPB10	SSUPBA10	5/8 L	.625	.875	1.63	.6245/.6240	.04	.09	–	–
SSUPB12	SSUPBA12	3/4 L	.750	.937	1.75	.7495/.7490	.06	.13	.08	.46/.41
SSUPB16	SSUPBA16	1 L	1.000	1.187	2.19	.9995/.9990	.08	.22	.16	.62/.56
SSUPB20	SSUPBA20	1 1/4 L	1.250	1.500	2.81	1.2495/1.2490	.08	.35	–	–
SSUPB24	SSUPBA24	1 1/2 L	1.500	1.750	3.25	1.4994/1.4989	.08	.50	.33	.93/.84

Part Number ⁽²⁾		A	A2	B	E ±.010	E1 ±.010	F	F1	G	G1	N		Pillow Block Mass lb	Dynamic ⁽¹⁾ Load Capacity lb _r
Fixed	Adjustable										Hole	Bolt		
SS6UPB8	SS6UPBA8	2.00	1.38	1.69	1.000	1.688	1.13	.25	.97	.44	.16	#6	.23	265
SSUPB10	SSUPBA10	2.50	1.75	1.94	1.125	2.125	1.44	.28	1.20	.69	.19	#8	.51	620
SSUPB12	SSUPBA12	2.75	1.88	2.06	1.250	2.375	1.56	.31	.94	.78	.19	#8	.62	1130
SSUPB16	SSUPBA16	3.25	2.38	2.81	1.750	2.875	1.94	.38	1.19	.91	.22	#10	1.24	1900
SSUPB20	SSUPBA20	4.00	3.00	3.63	2.000	3.500	2.50	.44	1.50	1.37	.22	#10	2.57	2350
SSUPB24	SSUPBA24	4.75	3.50	4.00	2.500	4.125	2.88	.50	1.75	1.13	.28	.25	3.94	3880

(1) The Dynamic Load Capacity is based on a rated travel life of 2 million inches. The actual Dynamic Load Capacity can be affected by the orientation of the bearing or the direction of the applied load. For dynamic load correction factors see polar graphs below.

(2) For part number description and specifications see page 27.

Note: For additional technical information, see the Engineering section beginning on page 262.

Inch – Super Smart Ball Bushing Bearings

Load/Life Graph

(Lines indicate limiting load for given Ball Bushing bearing)

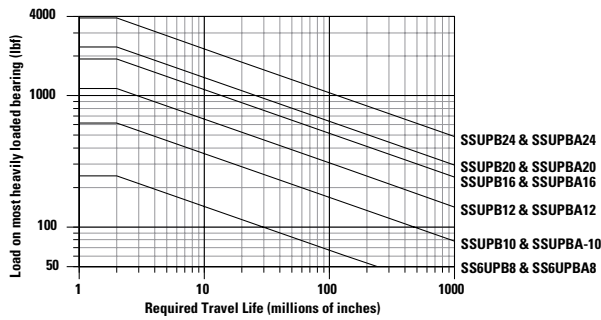

Determining Ball Bushing bearing Size

To determine the proper Ball Bushing bearing size enter the chart with the maximum load of the most heavily loaded bearing and the required travel life. Mark where the two lines intersect. All Ball Bushing bearing sizes that pass through or above and to the right of this point may be suitable for this application.

Note: For the purpose of using this chart.

Load on most heavily loaded bearing = maximum applied load/ K_0 .

Where K_0 can be determined from the Polar Graph to the right.

Polar Graphs

The actual Dynamic Load Capacity of a Ball Bushing bearing is determined by the orientation of the bearing or direction of the applied load. The load Correction Factor K_0 is found by knowing the direction of the applied load relative to the orientation of the bearings ball tracks and referring to the polar graph. To determine the actual Dynamic Load Capacity, multiply the proper correction factor by the Dynamic Load Capacity listed in the product table on the previous .

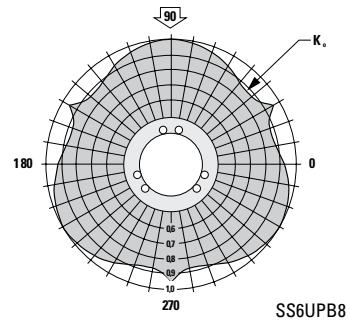
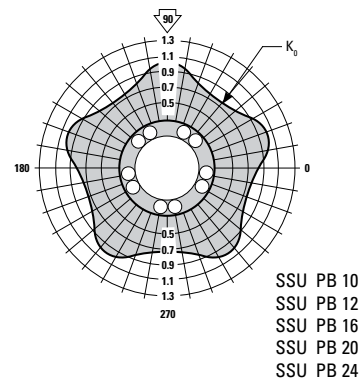

Inch – Super Smart Ball Bushing Bearings

Super Smart Ball Bushing Twin Pillow Blocks (Closed and Adjustable Type) for End Supported Applications

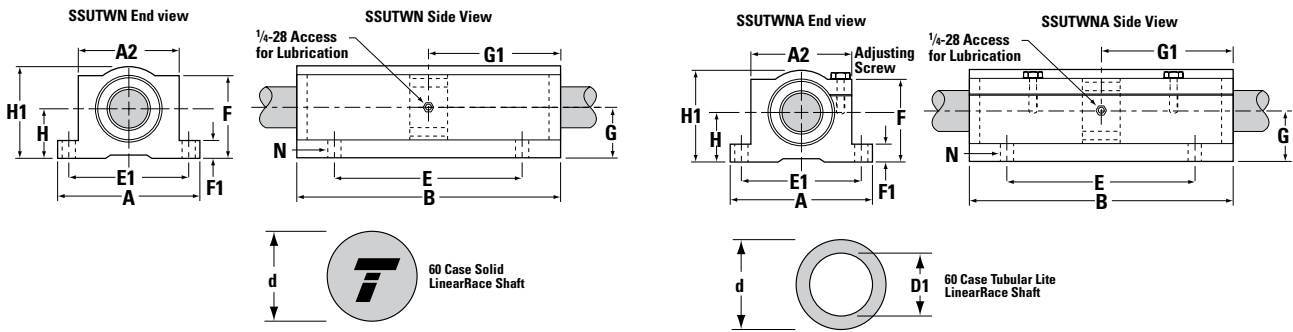
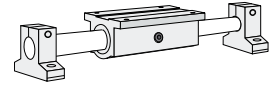

Super Smart Ball Bushing Twin Pillow Blocks (Closed Type, seal at both ends) and 60 Case LinearRace Shaft (Dim. in in.)

Part Number ⁽²⁾		60 Case LinearRace	Nominal Diameter	H ±.003	H1	60 Case LinearRace Diameter d	60 Case LinearRace Minimum Depth of Hardness	60 Case Solid LinearRace Mass lb/in	60 Case Tubular Lite LinearRace Mass lb/in	60 Case Tubular Lite LinearRace ID D1
Fixed	Adjustable									
SS6UTWN8	SS6UTWNA8	1/2 L	.500	.687	1.25	.4995/.4990	.04	.06	–	–
SSUTWN10	SSUTWNA10	5/8 L	.625	.875	1.63	.6245/.6240	.04	.09	–	–
SSUTWN12	SSUTWNA12	3/4 L	.750	.937	1.75	.7495/.7490	.06	.13	.08	.46/.41
SSUTWN16	SSUTWNA16	1 L	1.000	1.187	2.19	.9995/.9990	.08	.22	.16	.62/.56
SSUTWN20	SSUTWNA20	1 1/4 L	1.250	1.500	2.81	1.2495/1.2490	.08	.35	–	–
SSUTWN24	SSUTWNA24	1 1/2 L	1.500	1.750	3.25	1.4994/1.4989	.08	.50	.33	.93/.84

Part Number ⁽²⁾		A	A2	B	E ±.010	E1 ±.010	F	F1	G	G1	N		Pillow Block Mass lb	Dynamic ⁽¹⁾ Load Capacity lb _f
Fixed	Adjustable										Hole	Bolt		
SS6UTWN8	SS6UTWNA8	2.00	1.38	3.50	2.500	1.688	1.13	.25	.59	1.75	.16	#6	.46	530
SSUTWN10	SSUTWNA10	2.50	1.75	4.00	3.000	2.125	1.44	.28	.85	2.00	.19	#8	1.02	1240
SSUTWN12	SSUTWNA12	2.75	1.88	4.50	3.500	2.375	1.56	.31	.94	2.25	.19	#8	1.24	2260
SSUTWN16	SSUTWNA16	3.25	2.38	6.00	4.500	2.875	1.94	.38	1.19	3.00	.22	#10	2.48	3800
SSUTWN20	SSUTWNA20	4.00	3.00	7.50	5.500	3.500	2.50	.44	1.50	3.75	.22	#10	5.14	4700
SSUTWN24	SSUTWNA24	4.75	3.50	9.00	6.500	4.125	2.88	.50	1.75	4.50	.28	.25	8.08	7760

(1) The Dynamic Load Capacity is based on a rated travel life of 2 million inches. The actual Dynamic Load Capacity can be affected by the orientation of the bearing or the direction of the applied load. For dynamic load correction factors see polar graphs below. Dynamic load capacity is based on two bearings equally loaded.

(2) For part number description and specifications see page 27.

Note: For additional technical information, see the Engineering section beginning on page 262.

Inch – Super Smart Ball Bushing Bearings

Load/Life Graph

(Lines indicate limiting load for given Ball Bushing bearing)

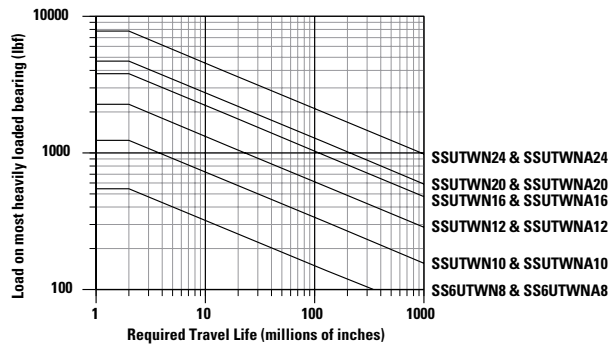

Determining Ball Bushing bearing Size

To determine the proper Ball Bushing bearing size enter the chart with the maximum load of the most heavily loaded bearing and the required travel life. Mark where the two lines intersect. All Ball Bushing bearing sizes that pass through or above and to the right of this point may be suitable for this application.

Note: For the purpose of using this chart.

Load on most heavily loaded bearing = maximum applied load/ K_0 .

Where K_0 can be determined from the Polar Graph to the right.

Polar Graphs

The actual Dynamic Load Capacity of a Ball Bushing bearing is determined by the orientation of the bearing or direction of the applied load. The load Correction Factor K_0 is found by knowing the direction of the applied load relative to the orientation of the bearings ball tracks and referring to the polar graph. To determine the actual Dynamic Load Capacity, multiply the proper correction factor by the Dynamic Load Capacity listed in the product table on the previous page.

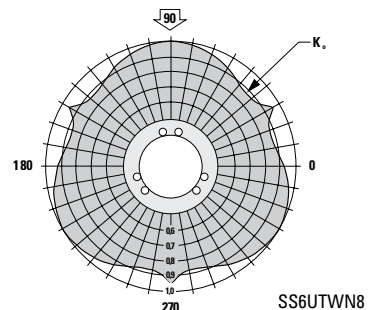
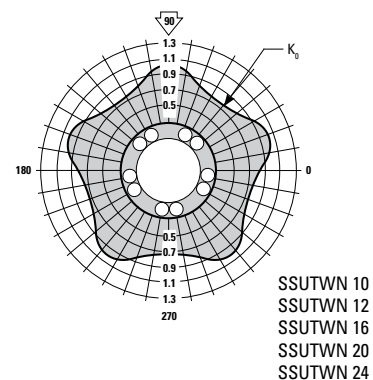

Inch – Super Smart Ball Bushing Bearings

Super Smart Ball Bushing Flanged Single and Twin Pillow Blocks for End Supported Applications

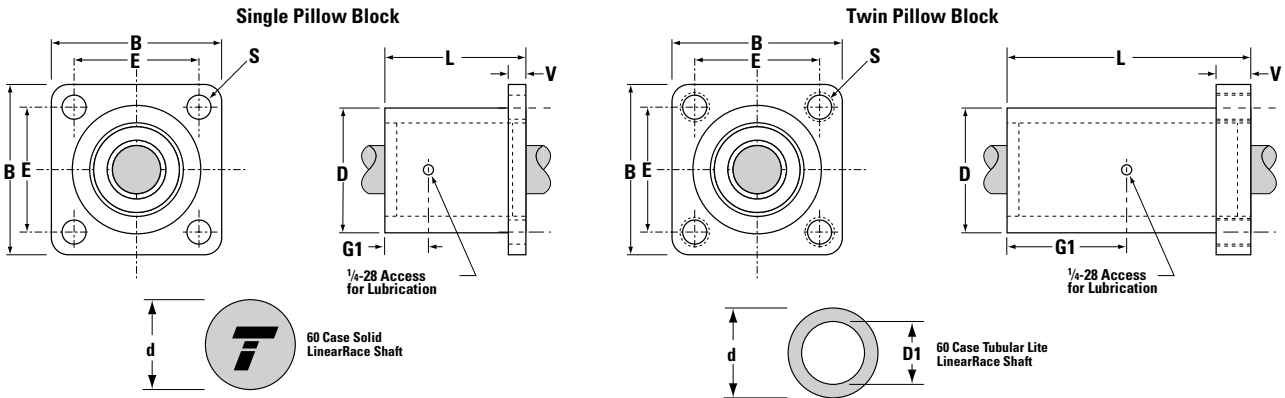
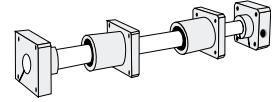

Super Smart Ball Bushing Flanged Pillow Blocks and 60 Case LinearRace Shaft (Dimensions in inches)

Part Number ⁽²⁾		Nominal Diameter	B	E ±.010	L	D	V	G1	S Hole Dia.	60 Case LinearRace Diameter d	60 Case LinearRace Minimum Depth of Hardness	60 Case Solid LinearRace Mass lb/in	60 Case Tubular Lite LinearRace Mass lb/in	60 Case Tubular Lite LinearRace ID D1	Pillow Block Mass lb	Dyn. ⁽¹⁾ Load Cap. lb _f
Super Smart Ball Bushing Flanged Pillow Block	60 Case LinearRace															
SS6UFB8	1/2 L	.500	1.63	1.250	1.69	1.25	.25	.72	.19	.4995/.4990	.04	.06	–	–	.23	265
SSUFB12	3/4 L	.750	2.38	1.750	2.06	1.75	.38	.89	.22	.7495/.7490	.06	.13	.08	.460/.416	.52	1130
SSUFB16	1 L	1.000	2.75	2.125	2.81	2.25	.50	1.27	.28	.9995/.9990	.08	.22	.16	.629/.569	1.04	1900
SSUFB20	1 1/4 L	1.250	3.50	2.750	3.63	3.00	.63	1.67	.35	1.2495/1.2490	.08	.35	–	–	2.21	2350
SSUFB24	1 1/2 L	1.500	4.00	3.125	4.00	3.62	.75	1.86	.41	1.4994/1.4989	.08	.50	.33	.93/.84	3.68	3880

Super Smart Ball Bushing Flanged Twin Pillow Blocks and 60 Case LinearRace Shaft (Dimensions in inches)

Part Number ⁽²⁾		Nominal Diameter	B	E ±.010	L	D	V	G1	S Thread	60 Case LinearRace Diameter d	60 Case LinearRace Minimum Depth of Hardness	60 Case Solid LinearRace Mass lb/in	60 Case Tubular Lite LinearRace Mass lb/in	60 Case Tubular Lite LinearRace ID D1	Pillow Block Mass lb	Dyn. ⁽¹⁾ Load Cap. lb _f
Super Smart Ball Bushing Flanged Twin Pillow Block	60 Case LinearRace															
SS6UTFB8	1/2 L	.500	1.63	1.250	3.20	1.25	.90	1.48	1/4-20	.4995/.4990	.04	.06	–	–	.45	530
SSUTFB12	3/4 L	.750	2.38	1.750	3.95	1.75	.90	1.98	1/4-20	.7495/.7490	.06	.13	.08	.460/.416	1.05	2260
SSUTFB16	1 L	1.000	2.75	2.125	5.33	2.25	.90	2.67	5/16-18	.9995/.9990	.08	.22	.16	.629/.569	1.95	3800
SSUTFB20	1 1/4 L	1.250	3.50	2.750	6.70	3.00	.90	3.35	5/16-18	1.2495/1.2490	.08	.35	–	–	4.06	4700
SSUTFB24	1 1/2 L	1.500	4.00	3.125	7.50	3.62	1.00	3.75	3/8-16	1.4994/1.4989	.08	.50	.33	.93/.84	6.84	7760

(1) The Dynamic Load Capacity is based on a rated travel life of 2 million inches. The actual Dynamic Load Capacity can be affected by the orientation of the bearing or the direction of the applied load. For dynamic load correction factors see polar graphs below. Dynamic load capacity of Twin Super Smart Flanged Pillow blocks is based on two bearings equally loaded.

(2) For part number description and specifications see page 27.

Note: For additional technical information, see the Engineering section beginning on page 262.

Inch – Super Smart Ball Bushing Bearings

Load/Life Graph

(Lines indicate limiting load for given Ball Bushing bearing)

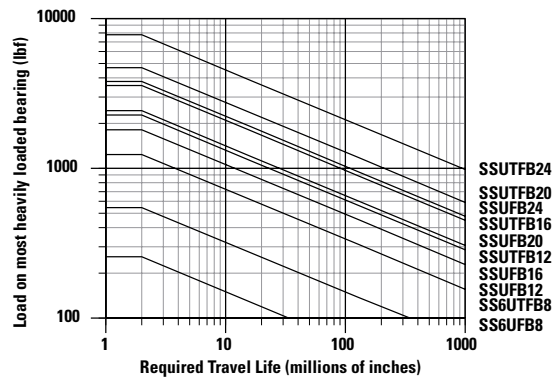

Determining Ball Bushing bearing Size

To determine the proper Ball Bushing bearing size enter the chart with the maximum load of the most heavily loaded bearing and the required travel life. Mark where the two lines intersect. All Ball Bushing bearing sizes that pass through or above and to the right of this point may be suitable for this application.

Note: For the purpose of using this chart.

Load on most heavily loaded bearing = maximum applied load/ K_0 .

Where K_0 can be determined from the Polar Graph to the right.

Polar Graphs

The actual Dynamic Load Capacity of a Ball Bushing bearing is determined by the orientation of the bearing or direction of the applied load. The load Correction Factor K_0 is found by knowing the direction of the applied load relative to the orientation of the bearings ball tracks and referring to the polar graph. To determine the actual Dynamic Load Capacity, multiply the proper correction factor by the Dynamic Load Capacity listed in the product table on the previous page.

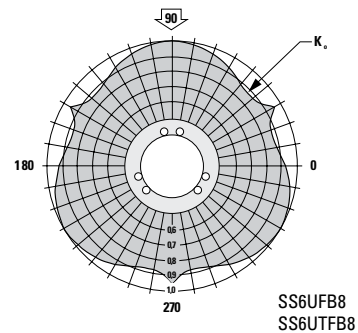
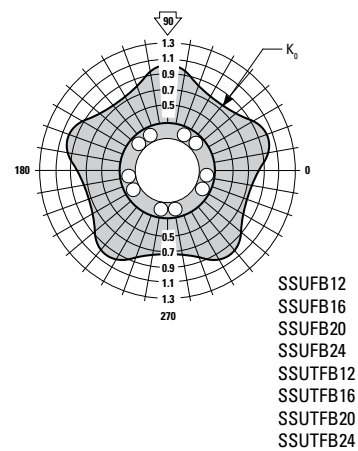

Inch – Super Smart Ball Bushing Bearings

Part Number Description and Specification

Super Smart Ball Bushing Bearings (Open Type) for Continuously Supported Applications

SSU160PNWW-CR

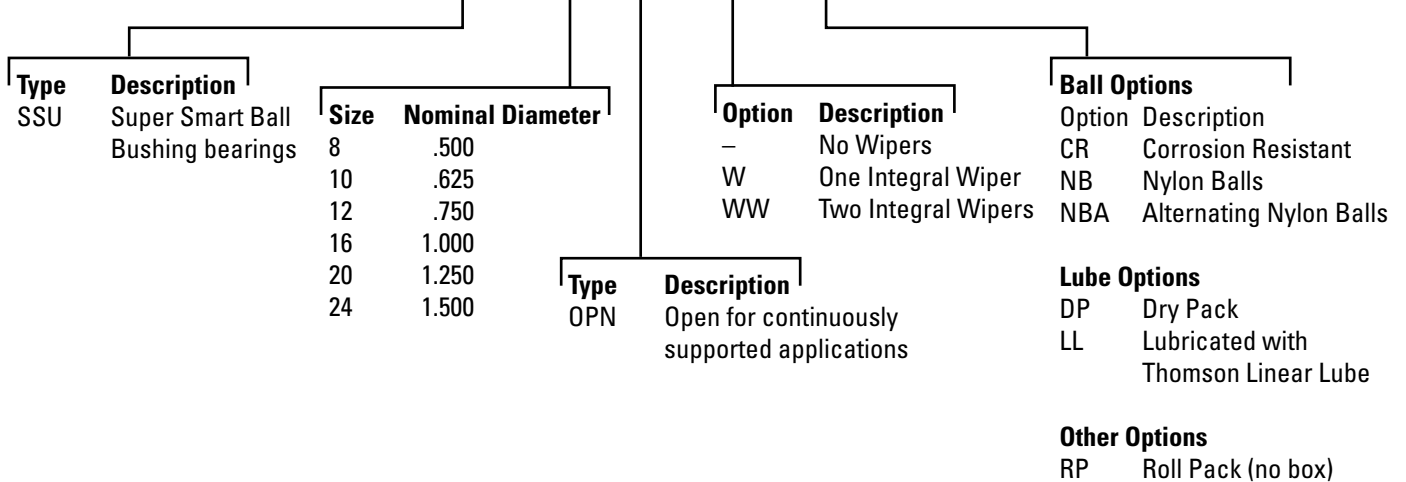

Super Smart Ball Bushing Pillow Blocks (Open Type) for Continuously Supported Applications

SSUPB016-CR

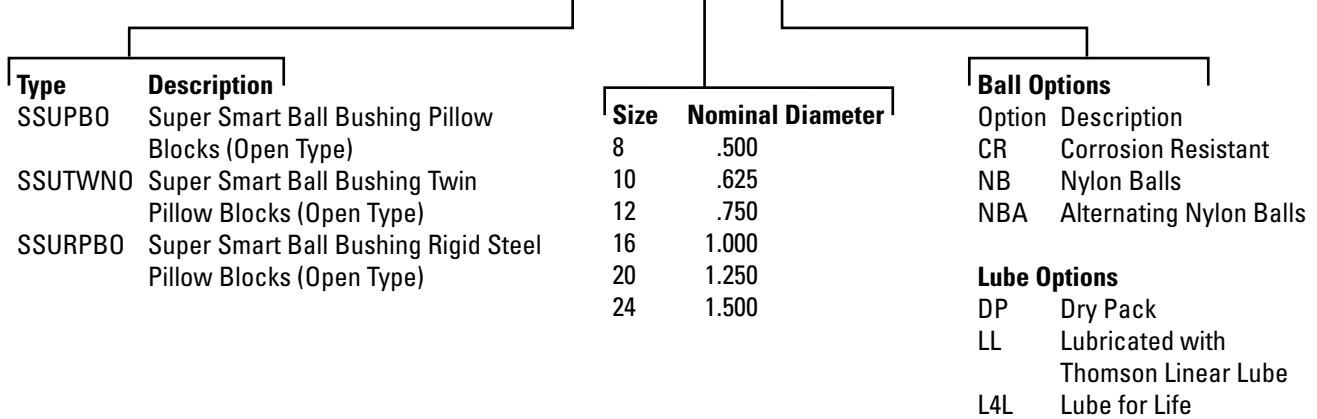

For addition informaiton on bearing options see page 273.

Inch – Super Smart Ball Bushing Bearings

Super Smart Ball Bushing Bearings (Open Type) for Continuously Supported Applications

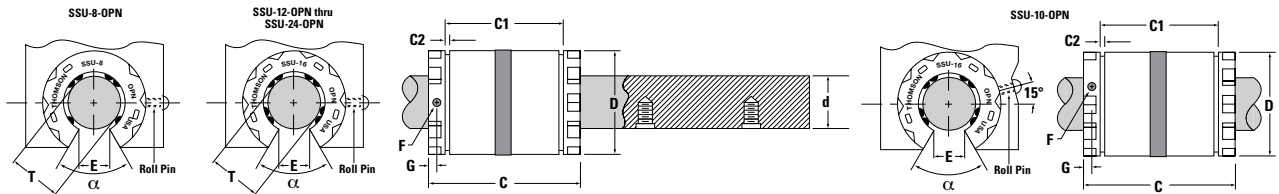
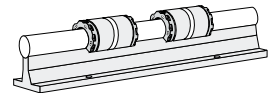

Super Smart Ball Bushing Bearings (Open Type) and 60 Case LinearRace Shafting (Dimensions in inches)

Part Number ⁽³⁾				Nom. Dia.	Length C	C1	C2 min.	Min. Slot Width E	Retention Hole		Angle deg α	Number of Ball Circuits	Ball Bushing bearing Mass lb
Without Integral Wipers	With one Integral Wiper	With two Integral Wipers	60 Case Linear Race*						Dia. F	Loc. G			
SSU80PN	SSU80PNW	SSU80PNWW	1/2 L PD	.500	1.250/1.230	1.032/1.012	.050	.31	.13	.62	90	6	.07
SSU100PN	SSU100PNW	SSU100PNWW	5/8 L PD	.625	1.500/1.480	1.125/1.095	.055	.34	.11	.13	60	8	.09
SSU120PN	SSU120PNW	SSU120PNWW	3/4 L PD	.750	1.625/1.605	1.285/1.255	.055	.41	.14	.13	60	8	.13
SSU160PN	SSU160PNW	SSU160PNWW	1 L PD	1.000	2.250/2.230	1.901/1.871	.068	.53	.14	.13	60	8	.24
SSU200PN	SSU200PNW	SSU200PNWW	1 1/4 L PD	1.250	2.625/2.600	2.031/1.991	.068	.62	.20	.19	50	8	.43
SSU240PN	SSU240PNW	SSU240PNWW	1 1/2 L PD	1.500	3.000/2.970	2.442/2.402	.086	.74	.20	.19	50	8	.80

* 60 Case begins on page 170.

Part Number ⁽³⁾			Working Bore Diameter T	Recommended Housing Bore Dia.		60 Case LinearRace Diameter d	Ball Bushing bearing/LinearRace Fit Up †		Dynamic Load Capacity lb _f ^(††)
Without Integral Wipers	With one Integral Wiper	With two Integral Wipers		Fixed D	Adjustable D		Fixed Diameter Housing	Adjustable Diameter Housing (Before Adjustment)	
SSU80PN	SSU80PNW	SSU80PNWW	.5000/.4995	.8755/.8750	.8760/.8750	.4995/.4990	.0015C/.0000	.002C/.0000	360
SSU100PN	SSU100PNW	SSU100PNWW	.6250/.6245	1.1255/1.1250	1.1260/1.1250	.6245/.6240	.0015C/.0000	.002C/.0000	620
SSU120PN	SSU120PNW	SSU120PNWW	.7500/.7495	1.2505/1.2500	1.2510/1.2500	.7495/.7490	.0015C/.0000	.002C/.0000	1130
SSU160PN	SSU160PNW	SSU160PNWW	1.0000/.9995	1.5630/1.5625	1.5635/1.5625	.9995/.9990	.0015C/.0000	.002C/.0000	1900
SSU200PN	SSU200PNW	SSU200PNWW	1.2500/1.2494	2.0008/2.0000	2.0010/2.0000	1.2495/1.2490	.0018C/.0001P	.002C/.0001P	2350
SSU240PN	SSU240PNW	SSU240PNWW	1.5000/1.4994	2.3760/2.3750	2.3760/2.3750	1.4994/1.4989	.0021C/.0000	.0021C/.0000	3880

† P = Preload, C = Clearance

(††) The Dynamic Load Capacity is based on a rated travel life of 2 million inches. The actual Dynamic Load Capacity can be affected by the orientation of the bearing or the direction of the applied load. For dynamic load correction factors see polar graphs to the right.

(3) For part number description and specifications see page 36.

Inch – Super Smart Ball Bushing Bearings

Load/Life Graph

(Lines indicate limiting load for given Ball Bushing bearing)

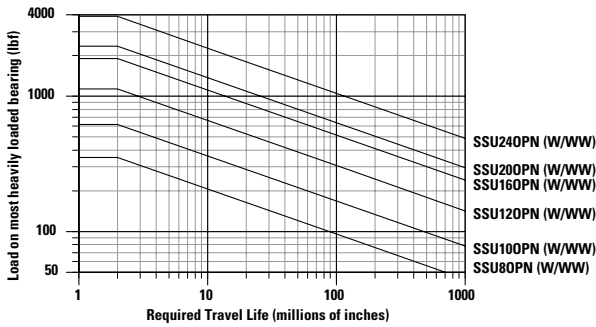

Determining Ball Bushing bearing Size

To determine the proper Ball Bushing bearing size enter the chart with the maximum load of the most heavily loaded bearing and the required travel life. Mark where the two lines intersect. All Ball Bushing bearing sizes that pass through or above and to the right of this point may be suitable for this application.

Note: For the purpose of using this chart.

Load on most heavily loaded bearing = maximum applied load/ K_0 .

Where K_0 can be determined from the Polar Graph to the right.

When using LSRA smart rail assemblies, the dynamic load capacity for side loaded or pull off applications must be derated by 75% or .25 times the dynamic load capacity.

Polar Graphs

The actual Dynamic Load Capacity of a Ball Bushing bearing is determined by the orientation of the bearing or direction of the applied load. The load Correction Factor K_0 is found by knowing the direction of the applied load relative to the orientation of the bearings ball tracks and referring to the polar graph. To determine the actual Dynamic Load Capacity, multiply the proper correction factor by the Dynamic Load Capacity listed in the product table on the previous page.

Note: For Super Smart Ball Bushing bearings and other extremely high load bearings, the bearing load capacity as indicated by the polar charts may be practically limited by the degree of shaft flexure acceptable, or the capacity of the shaft rail assembly fasteners. In such cases, the loads should be kept below these practical limits, however, the full corresponding life capacity benefits are still realized!

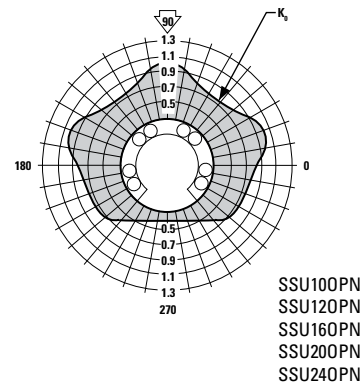
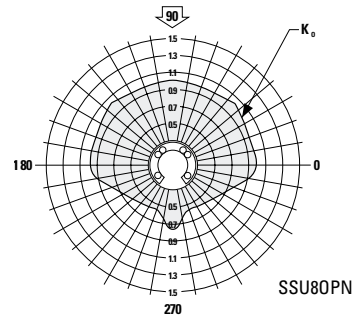

Inch – Super Smart Ball Bushing Bearings

Super Smart Ball Bushing Pillow Blocks (Open Type) for Continuously Supported Applications

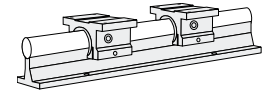

Inch Ball Bearing Bushing

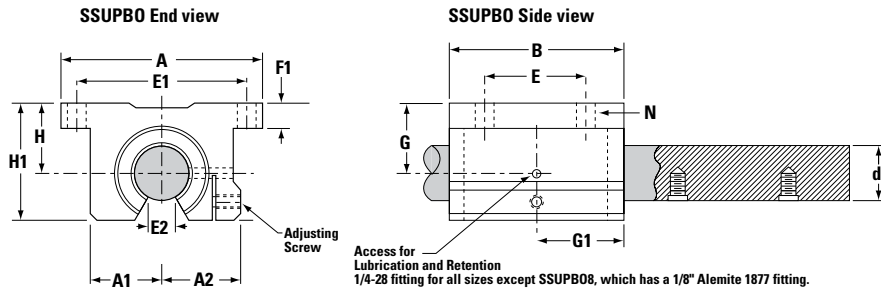

Super Smart Ball Bushing Pillow Blocks (Open Type) and 60 Case LinearRace (Dimensions in inches)

Part Number ⁽³⁾		Nominal Diameter	H ±.003	H1	60 Case LinearRace Diameter d
Super Smart Ball Bushing Pillow Block	60 Case LinearRace*				
SSUPB08	1/2 L PD	.500	.687	1.13	.4995/.4990
SSUPB010	5/8 L PD	.625	.875	1.44	.6245/.6240
SSUPB012	3/4 L PD	.750	.937	1.56	.7495/.7490
SSUPB016	1 L PD	1.000	1.187	2.00	.9995/.9990
SSUPB020	1 1/4 L PD	1.250	1.500	2.56	1.2495/1.2490
SSUPB024	1 1/2 L PD	1.500	1.750	2.94	1.4994/1.4989

* 60 Case begins on page 170.

Part Number ⁽³⁾	Super Smart Ball Bushing Pillow Block										Pillow Block Mass lb	Dynamic ^(††) Load Capacity lb _f		
	A	A1	A2	B	E ±.010	E1 ±.010	E2 min.	F1	G	G1			N Hole	N1 Bolt
SSUPB08	2.00	.69	.75	1.50	1.000	1.688	.31	.25	.50	.89	.16	#6	.23	360
SSUPB010	2.50	.88	.94	1.75	1.125	2.125	.34	.28	.55	.95	.19	#8	.41	620
SSUPB012	2.75	.94	1.00	1.88	1.250	2.375	.41	.31	.67	1.08	.19	#8	.51	1130
SSUPB016	3.25	1.19	1.25	2.63	1.750	2.875	.53	.38	.87	1.45	.22	#10	1.03	1900
SSUPB020	4.00	1.50	1.63	3.38	2.000	3.500	.62	.44	1.15	1.83	.22	#10	2.15	2350
SSUPB024	4.75	1.75	1.88	3.75	2.500	4.125	.74	.50	1.28	2.02	.28	.25	3.29	3880

(††) The Dynamic Load Capacity is based on a rated travel life of 2 million inches. The actual Dynamic Load Capacity can be affected by the orientation of the bearing or the direction of the applied load. For dynamic load correction factors see polar graphs below.

(3) For part number description and specifications see page 36.

Inch – Super Smart Ball Bushing Bearings

Load/Life Graph

(Lines indicate limiting load for given Ball Bushing bearing)

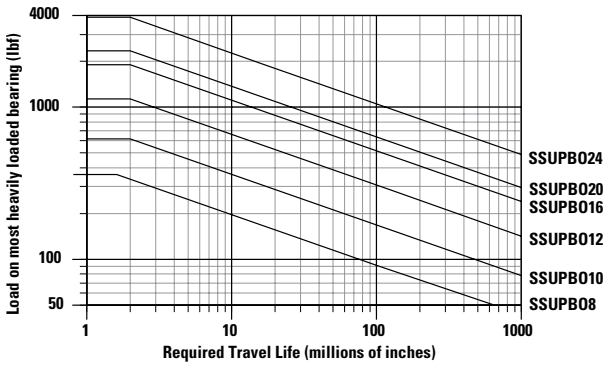

Determining Ball Bushing bearing Size

To determine the proper Ball Bushing bearing size enter the chart with the maximum load of the most heavily loaded bearing and the required travel life. Mark where the two lines intersect. All Ball Bushing bearing sizes that pass through or above and to the right of this point may be suitable for this application.

Note: For the purpose of using this chart.

Load on most heavily loaded bearing = maximum applied load/ K_0 .

Where K_0 can be determined from the Polar Graph to the right.

Polar Graphs

The actual Dynamic Load Capacity of a Ball Bushing bearing is determined by the orientation of the bearing or direction of the applied load. The load Correction Factor K_0 is found by knowing the direction of the applied load relative to the orientation of the bearings ball tracks and referring to the polar graph. To determine the actual Dynamic Load Capacity, multiply the proper correction factor by the Dynamic Load Capacity listed in the product table on the previous page.

Note: For Super Smart Ball Bushing bearings and other extremely high load bearings, the bearing load capacity as indicated by the polar charts may be practically limited by the degree of shaft flexure acceptable, or the capacity of the shaft rail assembly fasteners. In such cases, the loads should be kept below these practical limits, however, the full corresponding life capacity benefits are still realized!

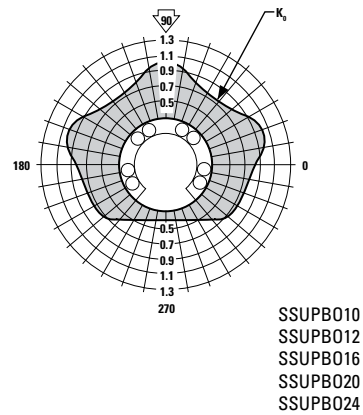
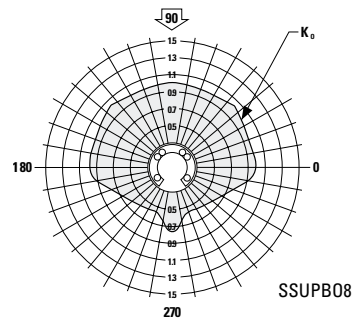

Inch – Super Smart Ball Bushing Bearings

Super Smart Ball Bushing Twin Pillow Blocks (Open Type) for Continuously Supported Applications

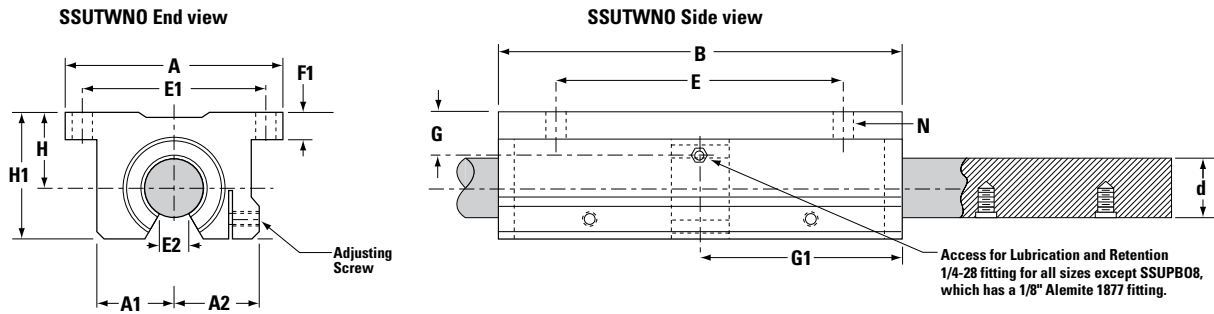
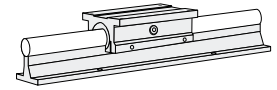

Super Smart Ball Bushing Twin Pillow Blocks (Open Type, seal at both ends) and 60 Case LinearRace (Dimensions in inches)

Part Number ⁽³⁾		Nominal Diameter	H ±.003	H1
Super Smart Ball Bushing Pillow Block	60 Case LinearRace*			
SSUTWN08	1/2 L PD	.500	.687	1.13
SSUTWN010	5/8 L PD	.625	.875	1.44
SSUTWN012	3/4 L PD	.750	.937	1.56
SSUTWN016	1 L PD	1.000	1.187	2.00
SSUTWN020	1 1/4 L PD	1.250	1.500	2.56
SSUTWN024	1 1/2 L PD	1.500	1.750	2.94

* 60 Case begins on page 170.

Part Number ⁽³⁾	A	A1	A2	B	E ±.010	E1 ±.010	E2 min.	F1	G	G1	N Hole	N1 Bolt	Pillow Block Mass lb	Dynamic ^(††) Load Capacity lb _f
SSUTWN08	2.00	.69	.75	3.50	2.500	1.688	.31	.25	.56	1.75	.16	#6	.46	720
SSUTWN010	2.50	.88	.94	4.00	3.000	2.125	.34	.28	.67	2.00	.19	#8	.82	1240
SSUTWN012	2.75	.94	1.00	4.50	3.500	2.375	.41	.31	.94	2.25	.19	#8	1.02	2260
SSUTWN016	3.25	1.19	1.25	6.00	4.500	2.875	.53	.38	1.20	3.00	.22	#10	2.06	3800
SSUTWN020	4.00	1.50	1.63	7.50	5.500	3.500	.62	.44	1.50	3.75	.22	#10	4.30	4700
SSUTWN024	4.75	1.75	1.88	9.00	6.500	4.125	.74	.50	1.75	4.50	.28	.25	6.88	7760

(††) The Dynamic Load Capacity is based on a rated travel life of 2 million inches. The actual Dynamic Load Capacity can be affected by the orientation of the bearing or the direction of the applied load. For dynamic load correction factors see polar graphs below.

(3) For part number description and specifications see page 36.

Inch – Super Smart Ball Bushing Bearings

Load/Life Graph

(Lines indicate limiting load for given Ball Bushing bearing)

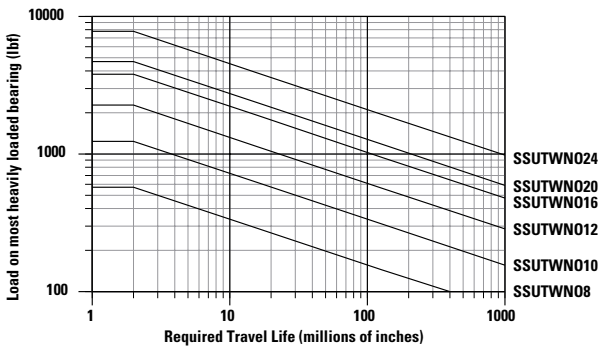

Determining Ball Bushing bearing Size

To determine the proper Ball Bushing bearing size enter the chart with the maximum load of the most heavily loaded bearing and the required travel life. Mark where the two lines intersect. All Ball Bushing bearing sizes that pass through or above and to the right of this point may be suitable for this application.

Note: For the purpose of using this chart.

Load on most heavily loaded bearing = maximum applied load/ K_0 .

Where K_0 can be determined from the Polar Graph to the right.

Polar Graphs

The actual Dynamic Load Capacity of a Ball Bushing bearing is determined by the orientation of the bearing or direction of the applied load. The load Correction Factor K_0 is found by knowing the direction of the applied load relative to the orientation of the bearings ball tracks and referring to the polar graph. To determine the actual Dynamic Load Capacity, multiply the proper correction factor by the Dynamic Load Capacity listed in the product table on the previous page.

Note: For Super Smart Ball Bushing bearings and other extremely high load bearings, the bearing load capacity as indicated by the polar charts may be practically limited by the degree of shaft flexure acceptable, or the capacity of the shaft rail assembly fasteners. In such cases, the loads should be kept below these practical limits, however, the full corresponding life capacity benefits are still realized!

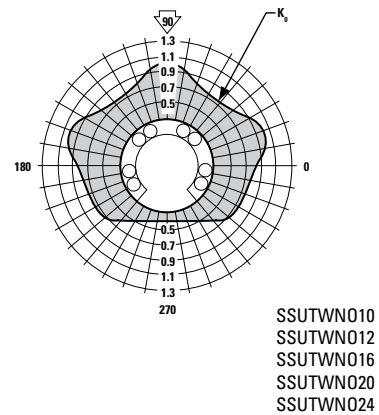
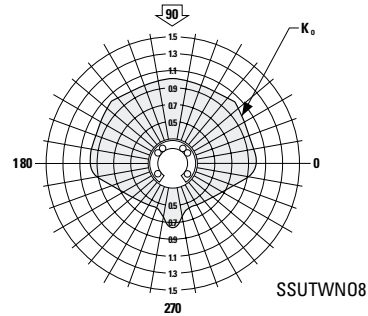

Inch – Super Smart Ball Bushing Bearings

Super Smart Ball Bushing Rigid Steel Pillow Blocks

(Open Type) for Continuously Supported Applications

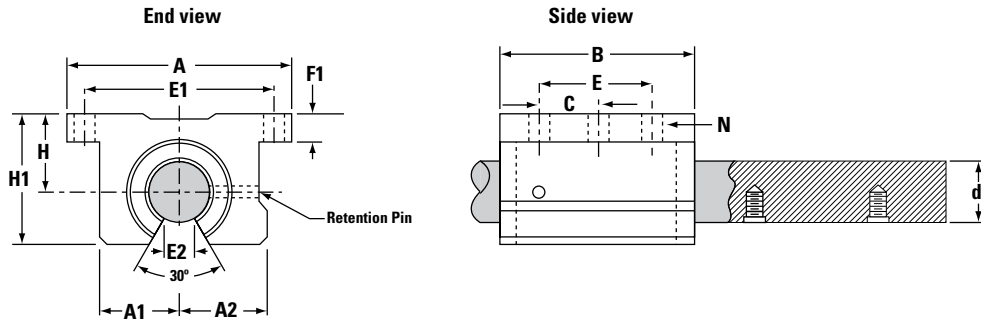
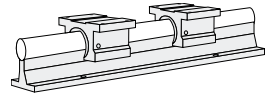

Rigid steel housing and high performance Super Smart Ball Bushing Bearing combine to reduce deflection and cost up to 66%.

Super Smart Ball Bushing Bearing Rigid Steel Pillow Blocks (Open Type, seal at both ends) and LinearRace (Dim. in in.)

Part Number ⁽³⁾		Nominal Diameter	H ±.003	H1	A	A1	A2	B
Super Smart Ball Bushing Rigid Steel Pillow Block	60 Case LinearRace* Shaft							
SSURPB012	3/4 L PD	.750	.937	1.56	2.75	.94	1.00	1.88
SSURPB016	1 L PD	1.000	1.187	2.00	3.25	1.19	1.25	2.63
SSURPB024	1 1/2 L PD	1.500	1.750	2.94	4.75	1.75	1.88	3.75

* 60 Case begins on page 170.

Part Number ⁽³⁾	60 Case LinearRace Diameter d	E ±.010	C ±.010	E1 ±.010	E2 min.	F1	N		Pillow Block Mass lb	Dynamic ^(††) Load Capacity lb _i
							Hole	Bolt		
SSURPB012	.7495/.7490	1.250	.625	2.375	.43	.31	.19	#8	1.10	1130
SSURPB016	.9995/.9990	1.750	.875	2.875	.56	.38	.22	#10	2.30	1900
SSURPB024	1.4994/1.4989	2.500	1.250	4.125	.81	.50	.28	.25	7.00	3880

(††) The Dynamic Load Capacity is based on a rated travel life of 2 million inches. The actual Dynamic Load Capacity can be affected by the orientation of the bearing or the direction of the applied load. For dynamic load correction factors see polar graphs below.

(3) For part number description and specifications see page 36.

Super Smart Ball Bushing Rigid Steel Pillow Blocks provide:

- **Faster settling time...Greater Productivity**
- **Less deflection...Greater Accuracy**
- **Highest Load Capacity...Smallest Envelope**
- **Longest Bearing Life...Greater Reliability**

Inch – Super Smart Ball Bushing Bearings

Polar Graphs

The actual Dynamic Load Capacity of a Ball Bushing bearing is determined by the orientation of the bearing or direction of the applied load. The load Correction Factor K_0 is found by knowing the direction of the applied load relative to the orientation of the bearings ball tracks and referring to the polar graph. To determine the actual Dynamic Load Capacity, multiply the proper correction factor by the Dynamic Load Capacity listed in the product table on the previous page.

Note: For Super Smart Ball Bushing bearings and other extremely high load bearings, the bearing load capacity as indicated by the polar charts may be practically limited by the degree of shaft flexure acceptable, or the capacity of the shaft rail assembly fasteners. In such cases, the loads should be kept below these practical limits, however, the full corresponding life capacity benefits are still realized!

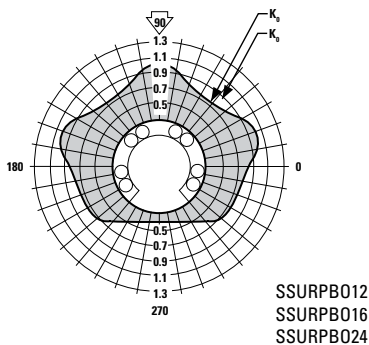

Inch – Super Smart Ball Bushing Bearings

Pick and Place X-Y System

Objective

Build an X-Y System that transfers the work piece between two separate machining stations.

Solution

Assemble the X-Y System utilizing Super Smart pillow blocks on end supported 60 Case LinearRace for the X-axis and continuously supported 60 Case LinearRace on the Y-axis. Utilize Thomson Ball Screw Assemblies for high speed positioning.

Products Specified

X-axis

- 2 - 1 1/2 L CTL x 48.00 in (60 Case LinearRace)
- 4 - SB24 (60 Case LinearRace End Support Blocks)
- 4 - SSUPB-24 (Super Smart Ball Bushing Pillow Blocks)
- 1 - 1 1/4 x .200 (Thomson Ball Screw Assembly)

Y-axis

- 2 - LSR-20 x 48.00 in (Low Profile 60 Case LinearRace Support Rail)
- 4 - SSUPB0-20 (Super Smart Ball Bushing Pillow Blocks)
- 1 - 1 1/4 x .200 (Thomson Ball Screw Assembly)
- 2 - 1 1/4 L CTL x 48.00 in (60 Case LinearRace)

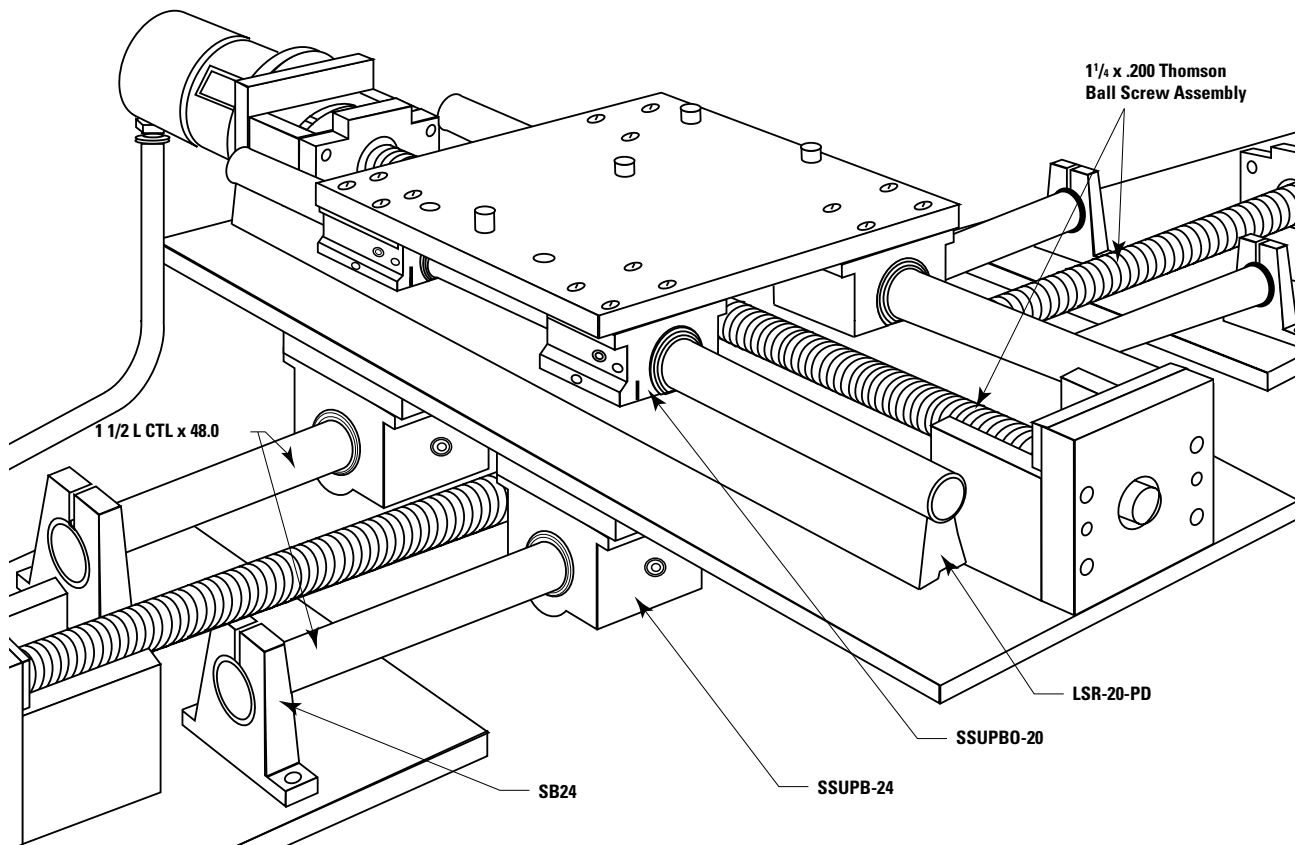

Inch – Super Ball Bushing Bearings

Super Ball Bushing Bearing Products

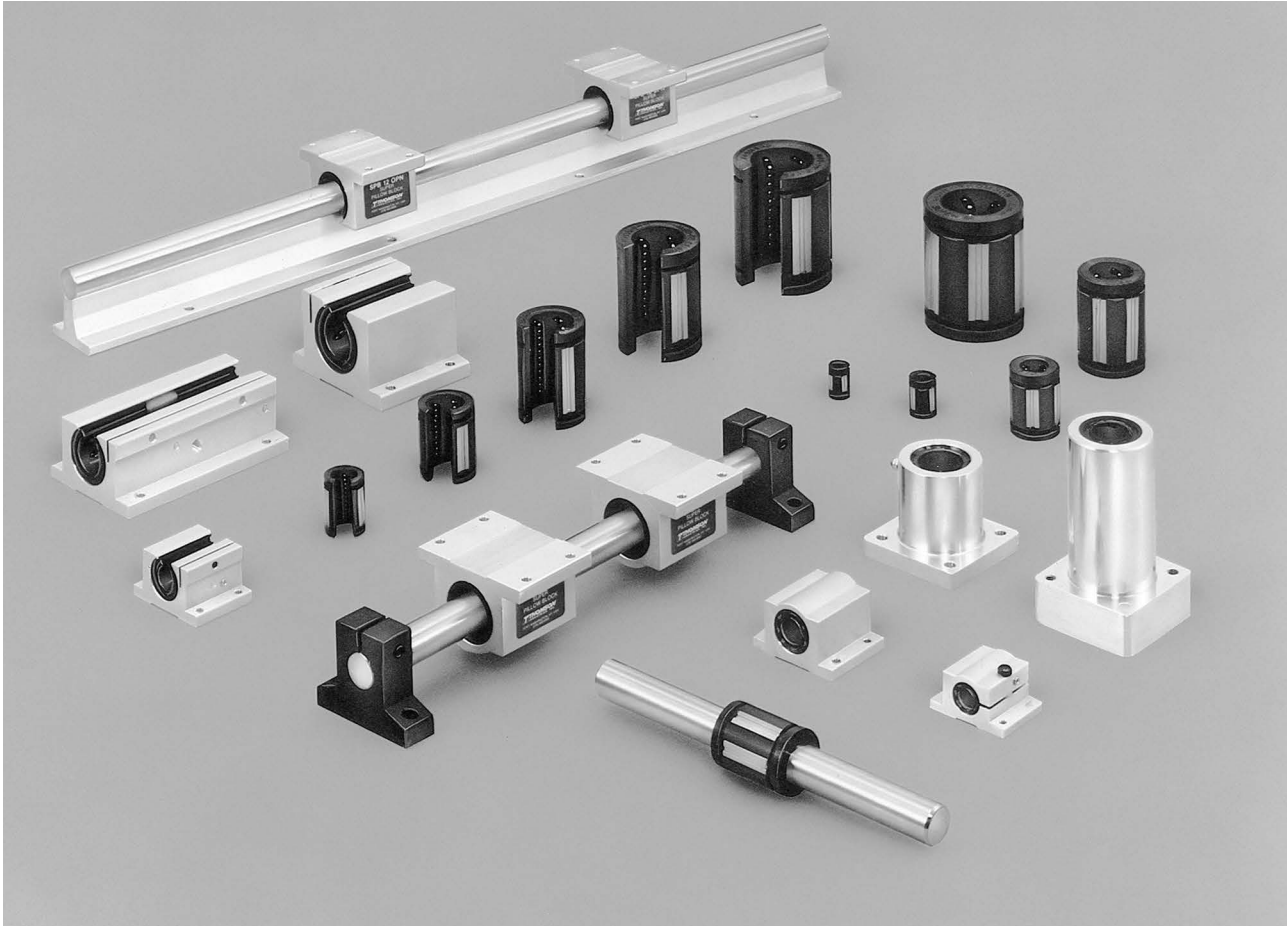

Thomson Super Ball Bushing Bearing products offer:

- A self-aligning capability up to $.5^\circ$ compensating for inaccuracies in base flatness or carriage machining.
- The RoundRail Advantage combined with the self-aligning feature, eliminating the need for derating factors commonly required for linear guides.
- Travel speeds up to 10 ft/s without a reduction in load capacity.
- Light weight, wear-resistant, engineered-polymer retainers and outer sleeves that reduce inertia and noise.
- Radially floating bearing plates. When installed in an adjustable housing, the Super Ball Bushing Bearing may be adjusted to a specific diametrical fit-up for accurate and repeatable movement.
- A constant coefficient of friction as low as .001.
- The use of smaller, less expensive drive motors, belts, linkages, gears and ball screws, when replacing high friction plain bearings.
- A closed configuration for end supported applications and an open configuration for continuously supported applications.
- Ready to install pillow blocks with double acting seals and an access for lubrication. Installation and downtime is minimized.
- Availability from over 1800 distributors, worldwide.

Inch – Super Ball Bushing Bearings

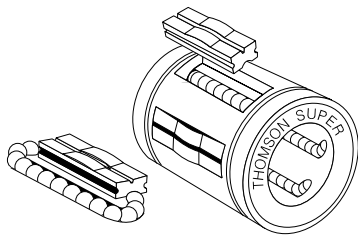

Figure 1

The Super Ball Bushing Bearing has been the industry standard for self-aligning linear bearings for over twenty years. This bearing provides three times the load capacity or 27 times the travel life of conventional linear bearings. This dramatic improvement in bearing performance significantly reduces downtime and maintenance, while increasing machine reliability. Thomson Industries, Inc. invented the Super Ball Bushing Bearing with many unique design features. Besides the dramatic increase in load capacity, the Super Ball Bushing Bearing is self-aligning, light weight and adjustable with a low coefficient of friction (Figure 1).

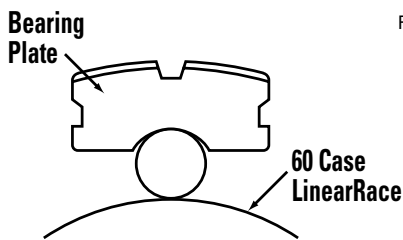

Figure 2

Three Times the Load Capacity

The bearing plates are hardened, bearing quality steel with ball conforming grooves (Figure 2). The groove is slightly larger than the ball diameter, providing an optimal area for ball contact. The greater ball to bearing plate contact provides the increase in load capacity or travel life.

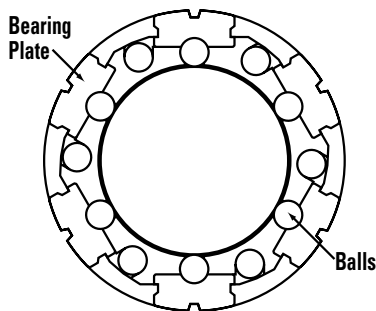

Figure 3

Cross-section of Super Ball Bushing Bearing

Zero Clearance Fit

The bearing plates are also designed to float radially (Figure 3). When the bearing is mounted in an adjustable housing, selected fit-ups can be achieved on the 60 Case LinearRace (shaft).

Self-Aligning

The Super Ball Bushing Bearing plates pivot $.5^\circ$ about their centers (Figure 4) to assure smooth entry and exit of the precision bearing balls. Each plate aligns itself automatically to compensate for inaccurate housing bore alignment, base flatness or carriage machining. This provides uniform ball loading, smooth ball recirculation and a constant coefficient of friction.

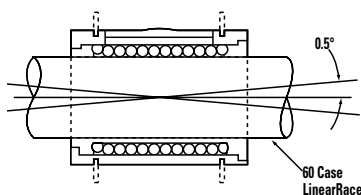

Figure 4

Smooth, Quiet Operation

The Super Ball Bushing Bearing's outer sleeve and retainer are made of wear-resistant, low-friction engineering polymer. It reduces inertia and operating noise levels significantly.

Inch – Super Ball Bushing Bearings

Part Number Description and Specification

Super Ball Bushing Bearings (Closed Type) for End Supported Applications

SUPER16DD-CR

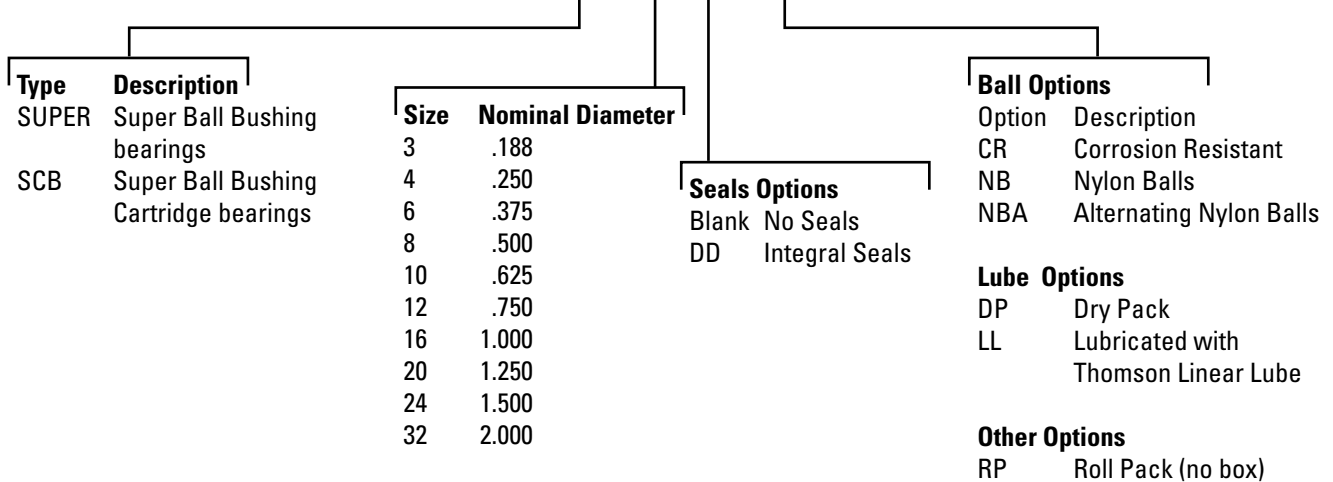

Super Ball Bushing Pillow Blocks (Closed Type) for End Supported Applications

SPB16ADJ-CR

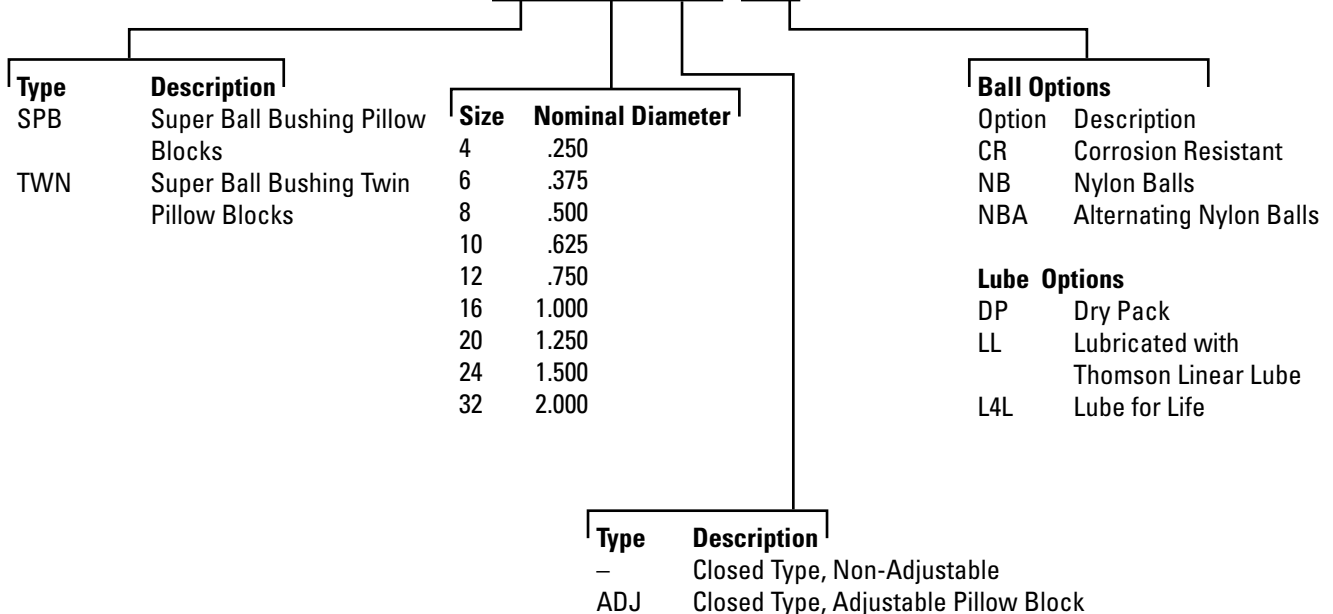

For addition informaiton on bearing options see page 273.

Inch – Super Ball Bushing Bearings

Super Ball Bushing Bearings (Closed Type) for End Supported Applications

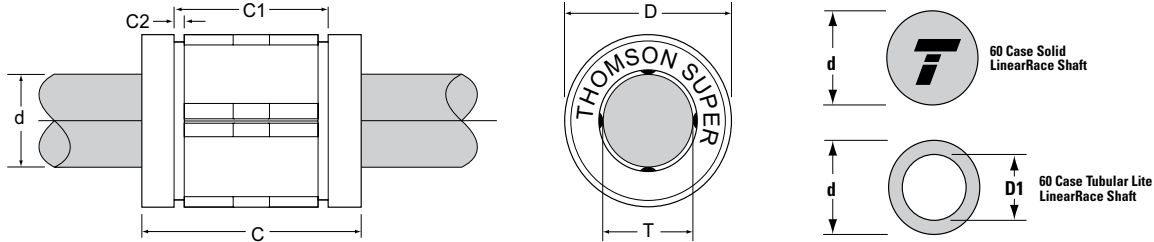
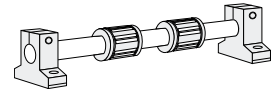

Super Ball Bushing Bearings (Closed Type) and 60 Case LinearRace (Dimensions in inches)

Part Number ⁽²⁾		Nominal Diameter	Length C	Distance Between Retaining Ring Grooves C1	Retaining Ring Groove min. C2	Number of Ball Circuits	Ball Bushing Bearing Mass lb	60 Case LinearRace Minimum Depth of Hardness	60 Case Solid LinearRace Mass lb/in	60 Case Tubular Lite LinearRace Mass lb/in	60 Case Tubular Lite LinearRace ID D1
Ball Bushing Bearing	60 Case Linear Race										
SUPER 3	3/16 L	.188	.562/.547	–	–	4	.003	.027	.008	–	–
SUPER 4	1/4 L	.250	.750/.735	.511/.501	.039	4	.01	.027	.01	–	–
SUPER 6	3/8 L	.375	.875/.860	.699/.689	.039	4	.02	.027	.03	–	–
SUPER 8	1/2 L	.500	1.250/1.230	1.032/1.012	.050	4	.04	.04	.06	–	–
SUPER 10	5/8 L	.625	1.500/1.480	1.105/1.095	.056	5	.10	.04	.09	–	–
SUPER 12	3/4 L	.750	1.625/1.605	1.270/1.250	.056	6	.14	.06	.13	.08	.46/.41
SUPER 16	1 L	1.000	2.250/2.230	1.884/1.864	.070	6	.25	.08	.22	.16	.62/.56
SUPER 20	1 1/4 L	1.250	2.625/2.600	2.004/1.984	.068	6	.45	.08	.35	–	–
SUPER 24	1 1/2 L	1.500	3.000/2.970	2.410/2.390	.086	6	.85	.08	.50	.33	.93/.84
SUPER 32	2 L	2.000	4.000/3.960	3.193/3.163	.105	6	1.45	.10	.89	.54	1.31/1.18

Part Number ⁽²⁾	Working Bore Diameter T	Recommended Housing Bore		60 Case LinearRace Diameter d	Ball Bushing Bearing/LinearRace Fit Up ‡		Dynamic ⁽¹⁾ Load Capacity lb _i
		Fixed D	Adjustable D		Fixed Diameter Housing	Adjustable Diameter Housing (Before Adjustment)	
SUPER 3	.1875/.1870	.3755/.3750	.3760/.3750	.1870/.1865	.0015C/.0000	.002C/.0000	35
SUPER 4	.2500/.2495	.5005/.5000	.5010/.5000	.2495/.2490	.0015C/.0000	.002C/.0000	60
SUPER 6	.3750/.3745	.6255/.6250	.6260/.6250	.3745/.3740	.0015C/.0000	.002C/.0000	100
SUPER 8	.5000/.4995	.8755/.8750	.8760/.8750	.4995/.4990	.0015C/.0000	.002C/.0000	255
SUPER 10	.6250/.6245	1.1255/1.1250	1.1260/1.1250	.6245/.6240	.0015C/.0000	.002C/.0000	450
SUPER 12	.7500/.7495	1.2505/1.2500	1.2510/1.2500	.7495/.7490	.0015C/.0000	.002C/.0000	600
SUPER 16	1.0000/.9995	1.5630/1.5625	1.5635/1.5625	.9995/.9990	.0015C/.0000	.002C/.0000	1050
SUPER 20	1.2500/1.2494	2.0008/2.0000	2.0010/2.0000	1.2495/1.2490	.0018C/.0001P	.002C/.0001P	1500
SUPER 24	1.5000/1.4994	2.3760/2.3750	2.3760/2.3750	1.4994/1.4989	.0021C/.0000	.0021C/.0000	2000
SUPER 32	2.0000/1.9992	3.0010/3.0000	3.0010/3.0000	1.9994/1.9987	.0023C/.0002P	.0023C/.0002P	3000

‡ P = Preload, C = Clearance

(1) The Dynamic Load Capacity is based on a rated travel life of 2 million inches. The actual Dynamic Load Capacity can be affected by the orientation of the bearing or the direction of the applied load. For dynamic load correction factors see polar graphs below.

(2) For part number description and specifications see page 48.

Note: For additional technical information, see the Engineering section beginning on page 262.

Inch – Super Ball Bushing Bearings

Load/Life Graph

(Lines indicate limiting load for given Ball Bushing bearing)

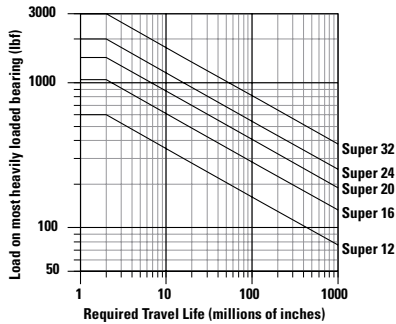
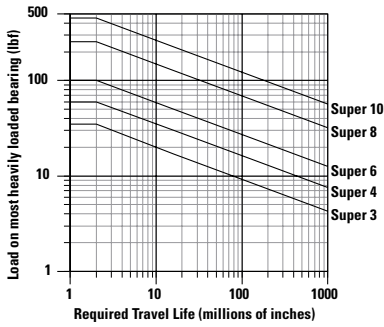

Determining Ball Bushing bearing Size

To determine the proper Ball Bushing bearing size enter the chart with the maximum load of the most heavily loaded bearing and the required travel life. Mark where the two lines intersect. All Ball Bushing bearing sizes that pass through or above and to the right of this point may be suitable for this application.

Note: For the purpose of using this chart.

Load on most heavily loaded bearing = maximum applied load/ K_0 .

Where K_0 can be determined from the Polar Graph to the right.

Polar Graphs

The actual Dynamic Load Capacity of a Ball Bushing bearing is determined by the orientation of the bearing or direction of the applied load. The load Correction Factor K_0 is found by knowing the direction of the applied load relative to the orientation of the bearings ball tracks and referring to the polar graph. To determine the actual Dynamic Load Capacity, multiply the proper correction factor by the Dynamic Load Capacity listed in the product table on the previous page.

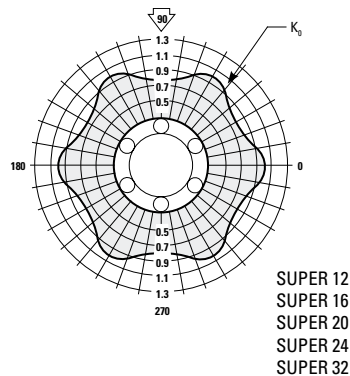
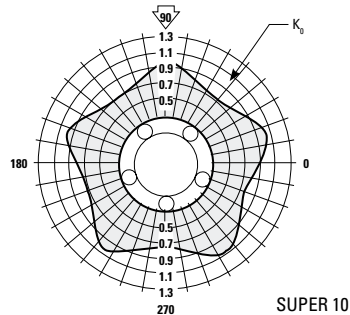
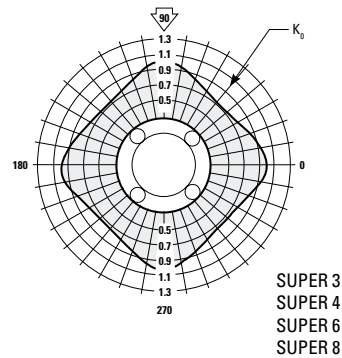

Inch – Super Ball Bushing Bearings

Sealed Super Ball Bushing Bearings (Closed Type) for End Supported Applications

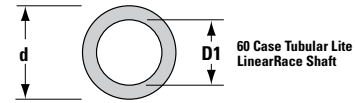
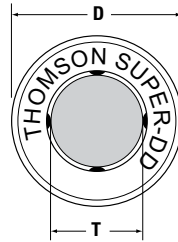
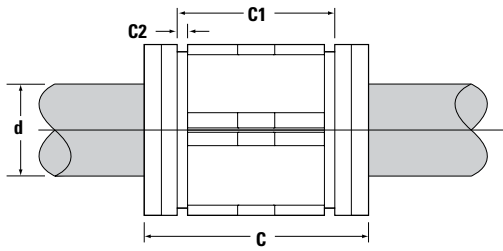
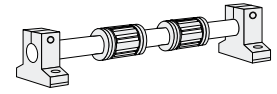

Sealed Super Ball Bushing Bearings (Closed Type, seal at both ends) and 60 Case LinearRace (Dimensions in inches)

Part Number ⁽²⁾		Nominal Diameter	Length C	Distance Between Retaining Ring Grooves C1	Retaining Ring Groove min. C2	Number of Ball Circuits	Ball Bushing Bearing Mass lb	60 Case LinearRace Minimum Depth of Hardness	60 Case Solid LinearRace Mass lb/in	60 Case Tubular Lite LinearRace Mass lb/in	60 Case Tubular Lite LinearRace ID D1
Ball Bushing Bearing	60 Case Linear Race										
SUPER8DD	1/2 L	.500	1.500/1.460	1.032/1.012	.050	4	.05	.04	.06	–	–
SUPER10DD	5/8 L	.625	1.750/1.710	1.105/1.095	.056	5	.11	.04	.09	–	–
SUPER12DD	3/4 L	.750	1.875/1.835	1.270/1.250	.056	6	.15	.06	.13	.08	.46/.41
SUPER16DD	1 L	1.000	2.625/2.585	1.884/1.864	.070	6	.27	.08	.22	.16	.62/.56

Part Number ⁽²⁾	Working Bore Diameter T	Recommended Housing Bore Dia.		60 Case LinearRace Diameter d	Ball Bushing Bearing/LinearRace Fit Up ‡		Dynamic ⁽¹⁾ Load Capacity lb _r
		Fixed D	Adjustable D		Fixed Diameter Housing	Adjustable Diameter Housing (Before Adjustment)	
SUPER8DD	.5000/.4995	.8750/.8755	.8750/.8760	.4995/.4990	.0015C/.0000	.002C/.0000	255
SUPER10DD	.6250/.6245	1.1250/1.1255	1.1250/1.1260	.6245/.6240	.0015C/.0000	.002C/.0000	450
SUPER12DD	.7500/.7495	1.2500/1.2505	1.2500/1.2510	.7495/.7490	.0015C/.0000	.002C/.0000	600
SUPER16DD	1.0000/.9995	1.5625/1.5630	1.5625/1.5635	.9995/.9990	.0015C/.0000	.002C/.0000	1050

‡ P = Preload, C = Clearance

(1) The Dynamic Load Capacity is based on a rated travel life of 2 million inches. The actual Dynamic Load Capacity can be affected by the orientation of the bearing or the direction of the applied load. For dynamic load correction factors see polar graphs below.

(2) For part number description and specifications see page 48.

Note: For additional technical information, see the Engineering section beginning on page 262.

Inch – Super Ball Bushing Bearings

Load/Life Graph

(Lines indicate limiting load for given Ball Bushing bearing)

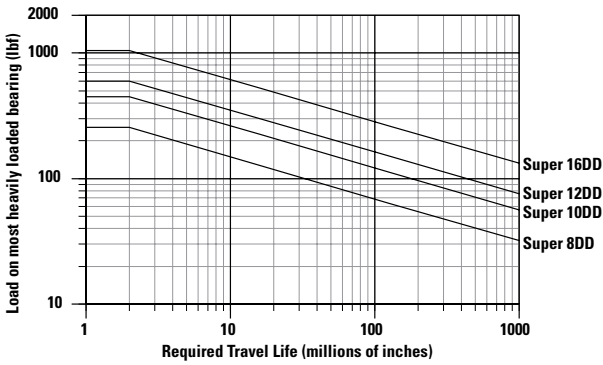

Determining Ball Bushing bearing Size

To determine the proper Ball Bushing bearing size enter the chart with the maximum load of the most heavily loaded bearing and the required travel life. Mark where the two lines intersect. All Ball Bushing bearing sizes that pass through or above and to the right of this point may be suitable for this application.

Note: For the purpose of using this chart.

Load on most heavily loaded bearing = maximum applied load/ K_0 .

Where K_0 can be determined from the Polar Graph to the right.

Polar Graphs

The actual Dynamic Load Capacity of a Ball Bushing bearing is determined by the orientation of the bearing or direction of the applied load. The load Correction Factor K_0 is found by knowing the direction of the applied load relative to the orientation of the bearings ball tracks and referring to the polar graph. To determine the actual Dynamic Load Capacity, multiply the proper correction factor by the Dynamic Load Capacity listed in the product table on the previous page.

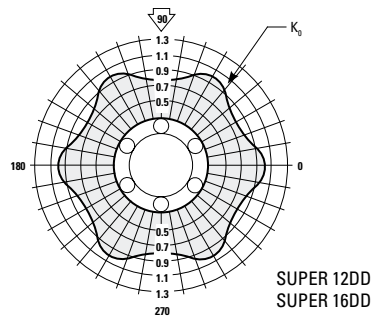
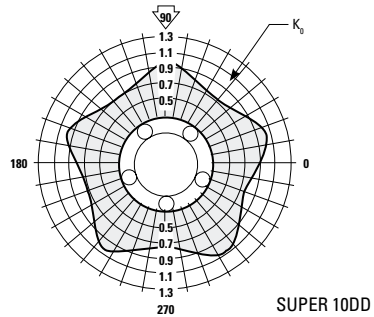
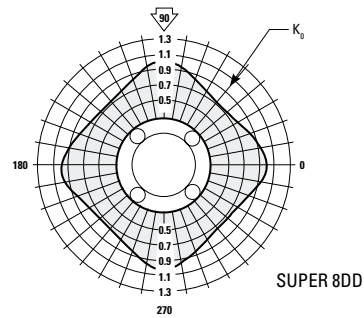

Inch – Super Ball Bushing Bearings

Super Ball Bushing Cartridge Bearings (Closed Type) for End Supported Applications

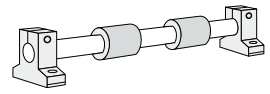

Inch Ball Bearing Bushing

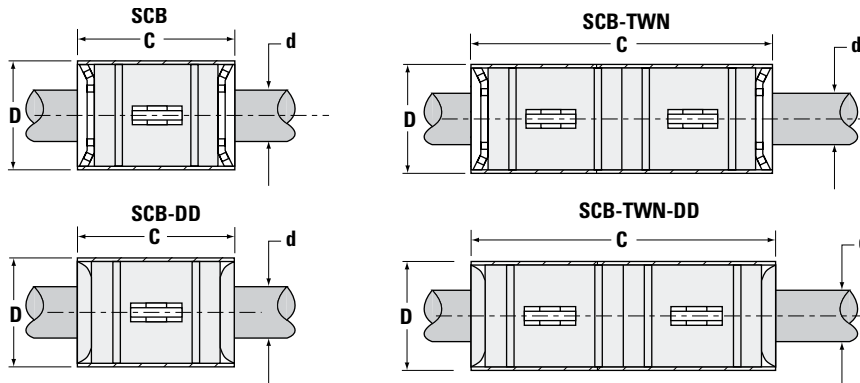

Super Ball Bushing Cartridge Bearings and 60 Case LinearRace (Dimensions in inches)

Part Number ⁽²⁾			Nominal Diameter	Length C ±.005	Number of Ball Circuits	Ball Bushing Mass w/out Seals lb	Ball Bushing Mass with Seals lb	60 Case LinearRace Diameter d	Nominal Outside Diameter D	Rec. Housing Bore Dia. Fixed	60 Case LinearRace Minimum Depth of Hardness	60 Case Solid LinearRace Mass lb/in	Dynamic ⁽¹⁾ Load Capacity lb _r
Without Seals	With Seals	60 Case Linear Race											
SCB4	SCB4DD	1/4 L	.250	1.000	4	.01	.02	.2495/.2490	.531/.529	.535/.533	.027	.01	60
SCB6	SCB6DD	3/8 L	.375	1.125	4	.02	.03	.3745/.3740	.656/.654	.660/.658	.027	.03	100
SCB8	SCB8DD	1/2 L	.500	1.500	4	.06	.07	.4995/.4990	.906/.904	.910/.908	.04	.06	255

Super Ball Bushing Twin Cartridge Bearings and 60 Case LinearRace (Dimensions in inches)

Part Number ⁽²⁾			Nominal Diameter	Length C ±.005	Number of Ball Circuits	Ball Bushing Mass w/out Seals lb	Ball Bushing Mass with Seals lb	60 Case LinearRace Diameter d	Nominal Outside Diameter D	Rec. Housing Bore Dia. Fixed	60 Case LinearRace Minimum Depth of Hardness	60 Case LinearRace Mass lb/in	Dynamic ⁽¹⁾ Load Capacity lb _r
Without Seals	With Seals	60 Case Linear Race											
SCB4TWN	SCB4TWNDD	1/4 L	.250	1.750	4	.02	.04	.2495/.2490	.531/.529	.535/.533	.027	.01	120
SCB6TWN	SCB6TWNDD	3/8 L	.375	2.000	4	.03	.04	.3745/.3740	.656/.654	.660/.658	.027	.03	200
SCB8TWN	SCB8TWNDD	1/2 L	.500	2.750	4	.12	.13	.4995/.4990	.906/.904	.910/.908	.04	.06	510

(1) The Dynamic Load Capacity is based on a rated travel life of 2 million inches. The actual Dynamic Load Capacity can be affected by the orientation of the bearing or the direction of the applied load. For dynamic load correction factors see polar graphs below. Dynamic load capacity of Twin Super Cartridge bearing is based on two bearings equally loaded.

(2) For part number description and specifications see page 48.

Note: For additional technical information, see the Engineering section beginning on page 262.

Inch – Super Ball Bushing Bearings

Load/Life Graph

(Lines indicate limiting load for given Ball Bushing Cartridge bearing)

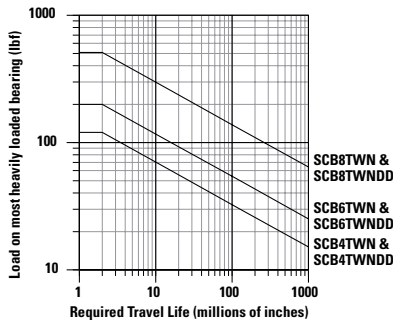
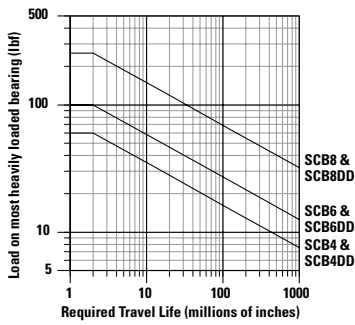

Polar Graphs

The actual Dynamic Load Capacity of a Ball Bushing bearing is determined by the orientation of the bearing or direction of the applied load. The load Correction Factor K_0 is found by knowing the direction of the applied load relative to the orientation of the bearings ball tracks and referring to the polar graph. To determine the actual Dynamic Load Capacity, multiply the proper correction factor by the Dynamic Load Capacity listed in the product table on the previous page.

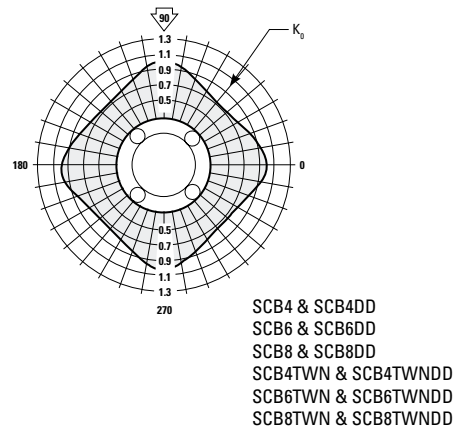

Determining Ball Bushing bearing Size

To determine the proper Ball Bushing bearing size enter the chart with the maximum load of the most heavily loaded bearing and the required travel life. Mark where the two lines intersect. All Ball Bushing bearing sizes that pass through or above and to the right of this point may be suitable for this application.

Note: For the purpose of using this chart.

Load on most heavily loaded bearing = maximum applied load/ K_0 .

Where K_0 can be determined from the Polar Graph to the right.

Inch – Super Ball Bushing Bearings

Super Ball Bushing Pillow Blocks (Closed and Adjustable Type) for End Supported Applications

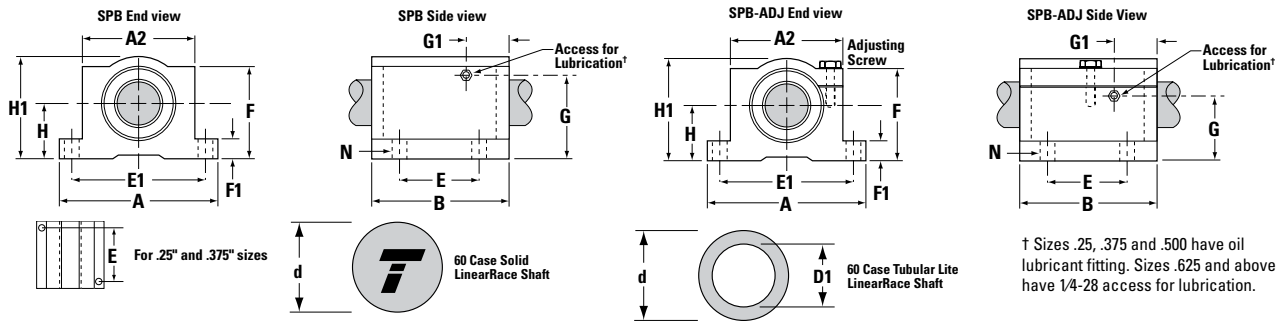
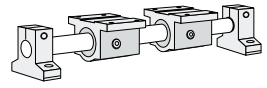

Super Ball Bushing Pillow Blocks (Closed and Adjustable Types, seal at both ends) and 60 Case LinearRace (Dim. in in.)

Part Number ⁽²⁾		60 Case LinearRace	Nominal Diameter	H ±.003	H1	60 Case LinearRace Diameter d	60 Case LinearRace Minimum Depth of Hardness	60 Case Solid LinearRace Mass lb/in	60 Case Tubular Lite LinearRace Mass lb/in	60 Case Tubular Lite LinearRace ID D1
Fixed	Adjustable									
SPB4	SPB4ADJ	1/4 L	.250	.437	.81	.2495/.2490	.027	.01	–	–
SPB6	SPB6ADJ	3/8 L	.375	.500	.94	.3745/.3740	.027	.03	–	–
SPB8	SPB8ADJ	1/2 L	.500	.687	1.25	.4995/.4990	.04	.06	–	–
SPB10	SPB10ADJ	5/8 L	.625	.875	1.63	.6245/.6240	.04	.09	–	–
SPB12	SPB12ADJ	3/4 L	.750	.937	1.75	.7495/.7490	.06	.13	.08	.46/.41
SPB16	SPB16ADJ	1 L	1.000	1.187	2.19	.9995/.9990	.08	.22	.16	.62/.56
SPB20	SPB20ADJ	1 1/4 L	1.250	1.500	2.81	1.2495/1.2490	.08	.35	–	–
SPB24	SPB24ADJ	1 1/2 L	1.500	1.750	3.25	1.4994/1.4989	.08	.50	.33	.93/.84
SPB32	SPB32ADJ	2 L	2.000	2.125	4.06	1.9994/1.9987	.10	.89	.54	1.31/1.18

Part Number ⁽²⁾		A	A2	B	E ±.010	E1 ±.010	F	F1	G	G1	N		Pillow Block Mass lb	Dynamic ⁽¹⁾ Load Capacity lb _f
Fixed	Adjustable										Hole	Bolt		
SPB4	SPB4ADJ	1.63	1.00	1.19	.750	1.313	.75	.19	.60	.41	.16	#6	.10	60
SPB6	SPB6ADJ	1.75	1.13	1.31	.875	1.438	.88	.19	.70	.41	.16	#6	.13	100
SPB8	SPB8ADJ	2.00	1.38	1.69	1.000	1.688	1.13	.25	.97	.44	.16	#6	.20	255
SPB10	SPB10ADJ	2.50	1.75	1.94	1.125	2.125	1.44	.28	1.20	.69	.19	#8	.50	450
SPB12	SPB12ADJ	2.75	1.88	2.06	1.250	2.375	1.56	.31	.94	.78	.19	#8	.60	600
SPB16	SPB16ADJ	3.25	2.38	2.81	1.750	2.875	1.94	.38	1.19	.91	.22	#10	1.20	1050
SPB20	SPB20ADJ	4.00	3.00	3.63	2.000	3.500	2.50	.44	1.50	1.37	.22	#10	2.50	1500
SPB24	SPB24ADJ	4.75	3.50	4.00	2.500	4.125	2.88	.50	1.75	1.13	.28	1/4	3.80	2000
SPB32	SPB32ADJ	6.00	4.50	5.00	3.250	5.250	3.63	.63	1.30	1.25	.41	3/8	7.00	3000

(1) The Dynamic Load Capacity is based on a rated travel life of 2 million inches. The actual Dynamic Load Capacity can be affected by the orientation of the bearing or the direction of the applied load. For dynamic load correction factors see polar graphs below.

(2) For part number description and specifications see page 48.

Note: For additional technical information, see the Engineering section beginning on page 262.

Inch – Super Ball Bushing Bearings

Load/Life Graph

(Lines indicate limiting load for given Ball Bushing Pillow Block)

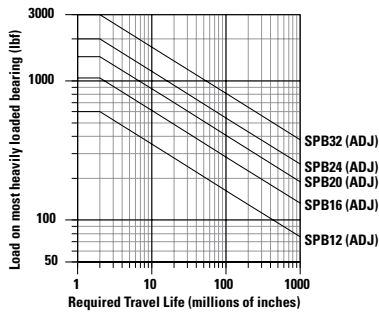
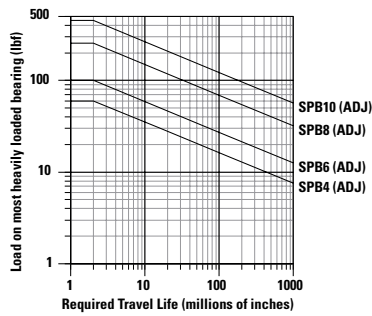

Determining Ball Bushing bearing Size

To determine the proper Ball Bushing bearing size enter the chart with the maximum load of the most heavily loaded bearing and the required travel life. Mark where the two lines intersect. All Ball Bushing bearing sizes that pass through or above and to the right of this point may be suitable for this application.

Note: For the purpose of using this chart.

Load on most heavily loaded bearing = maximum applied load/ K_0 .

Where K_0 can be determined from the Polar Graph to the right.

Polar Graphs

The actual Dynamic Load Capacity of a Ball Bushing bearing is determined by the orientation of the bearing or direction of the applied load. The load Correction Factor K_0 is found by knowing the direction of the applied load relative to the orientation of the bearings ball tracks and referring to the polar graph. To determine the actual Dynamic Load Capacity, multiply the proper correction factor by the Dynamic Load Capacity listed in the product table on the previous page.

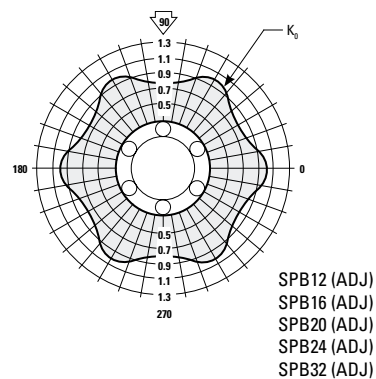
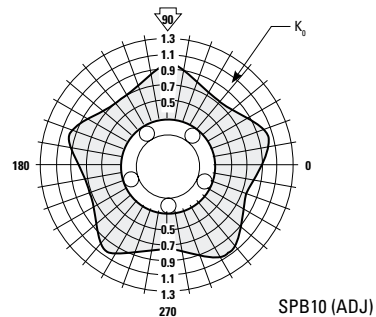
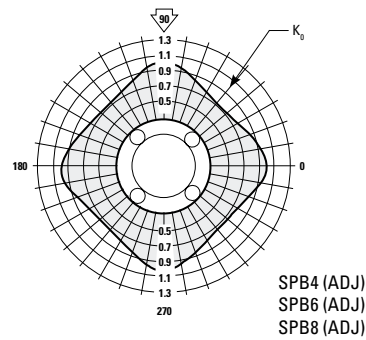

Inch – Super Ball Bushing Bearings

Super Ball Bushing Twin Pillow Blocks (Closed Type) for End Supported Applications

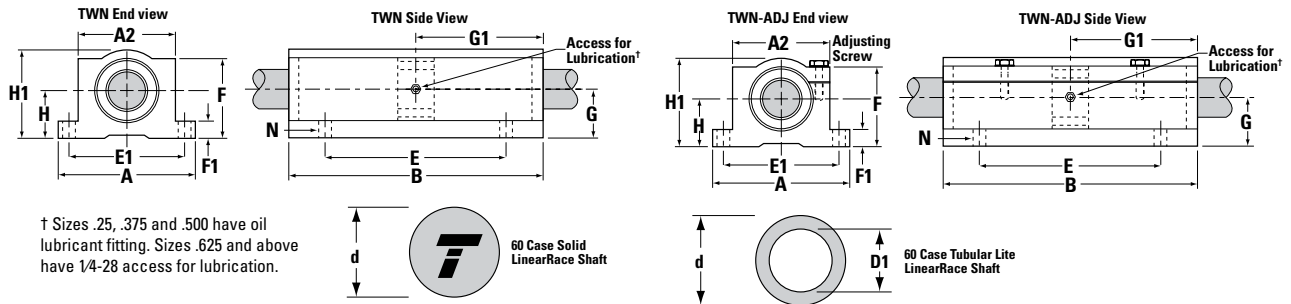
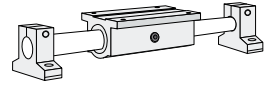

Super Ball Bushing Twin Pillow Blocks (Closed and Adjustable Type, seal at both ends) and LinearRace (Dim. in in.)

Part Number ⁽²⁾		60 Case LinearRace	Nominal Diameter	H ±.003	H1	60 Case LinearRace Diameter d	60 Case LinearRace Minimum Depth of Hardness	60 Case Solid LinearRace Mass lb/in	60 Case Tubular Lite LinearRace Mass lb/in	60 Case Tubular Lite LinearRace ID D1
Fixed	Adjustable									
TWN4	TWN4ADJ	1/4 L	.250	.437	.81	.2495/.2490	.027	.01	–	–
TWN6	TWN6ADJ	3/8 L	.375	.500	.94	.3745/.3740	.027	.03	–	–
TWN8	TWN8ADJ	1/2 L	.500	.687	1.25	.4995/.4990	.04	.06	–	–
TWN10	TWN10ADJ	5/8 L	.625	.875	1.63	.6245/.6240	.04	.09	–	–
TWN12	TWN12ADJ	3/4 L	.750	.937	1.75	.7495/.7490	.06	.13	.08	.46/.41
TWN16	TWN16ADJ	1 L	1.000	1.187	2.19	.9995/.9990	.08	.22	.16	.62/.56
TWN20	TWN20ADJ	1 1/4 L	1.250	1.500	2.81	1.2495/1.2490	.08	.35	–	–
TWN24	TWN24ADJ	1 1/2 L	1.500	1.750	3.25	1.4994/1.4989	.08	.50	.33	.93/.84

Part Number ⁽²⁾		A	A2	B	E ±.010	E1 ±.010	F	F1	G	G1	N		Pillow Block Mass lb	Dynamic ⁽¹⁾ Load Capacity lb _i
Fixed	Adjustable										Hole	Bolt		
TWN4	TWN4ADJ	1.63	1.00	2.50	2.000	1.313	.75	.19	.44	1.25	.16	#6	.19	120
TWN6	TWN6ADJ	1.75	1.13	2.75	2.250	1.438	.88	.19	.50	1.37	.16	#6	.25	200
TWN8	TWN8ADJ	2.00	1.38	3.50	2.500	1.688	1.13	.25	.59	1.75	.16	#6	.40	510
TWN10	TWN10ADJ	2.50	1.75	4.00	3.000	2.125	1.44	.28	.85	2.00	.19	#8	1.00	900
TWN12	TWN12ADJ	2.75	1.88	4.50	3.500	2.375	1.56	.31	.94	2.25	.19	#8	1.20	1200
TWN16	TWN16ADJ	3.25	2.38	6.00	4.500	2.875	1.94	.38	1.19	3.00	.22	#10	2.40	2100
TWN20	TWN20ADJ	4.00	3.00	7.50	5.500	3.500	2.50	.44	1.50	3.75	.22	#10	5.00	3000
TWN24	TWN24ADJ	4.75	3.50	9.00	6.500	4.125	2.88	.50	1.75	4.50	.28	1/4	7.80	4000

(1) The Dynamic Load Capacity is based on a rated travel life of 2 million inches. The actual Dynamic Load Capacity can be affected by the orientation of the bearing or the direction of the applied load. For dynamic load correction factors see polar graphs below. Dynamic load capacity of Super Ball Bushing Twin Pillow Blocks is based on two bearings equally loaded.

(2) For part number description and specifications see page 48.

Note: For additional technical information, see the Engineering section beginning on page 262.

Inch – Super Ball Bushing Bearings

Load/Life Graph

(Lines indicate limiting load for given Ball Bushing Pillow Block)

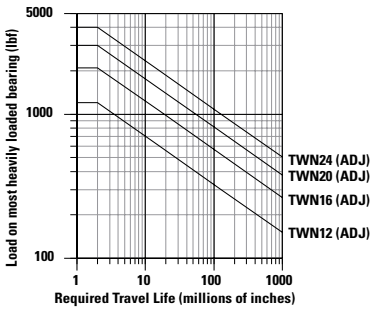
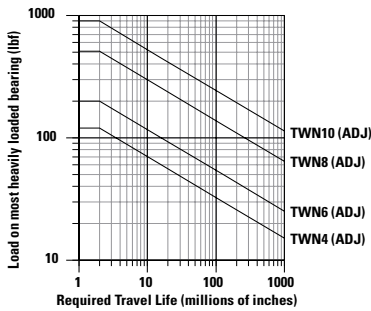

Determining Ball Bushing bearing Size

To determine the proper Ball Bushing bearing size enter the chart with the maximum load of the most heavily loaded bearing and the required travel life. Mark where the two lines intersect. All Ball Bushing bearing sizes that pass through or above and to the right of this point may be suitable for this application.

Note: For the purpose of using this chart.

Load on most heavily loaded bearing = maximum applied load/ K_0 .

Where K_0 can be determined from the Polar Graph to the right.

Polar Graphs

The actual Dynamic Load Capacity of a Ball Bushing bearing is determined by the orientation of the bearing or direction of the applied load. The load Correction Factor K_0 is found by knowing the direction of the applied load relative to the orientation of the bearings ball tracks and referring to the polar graph. To determine the actual Dynamic Load Capacity, multiply the proper correction factor by the Dynamic Load Capacity listed in the product table on the previous page.

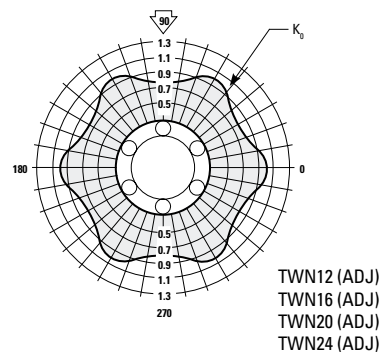
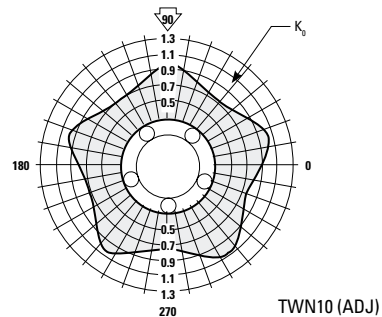
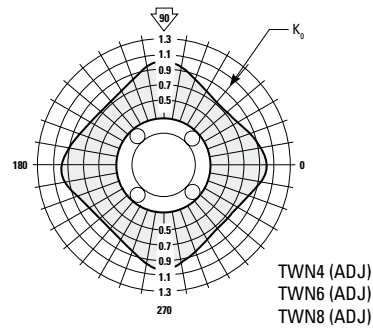

Inch – Super Ball Bushing Bearings

Part Number Description and Specification

Super Ball Bushing Bearings (Open Type) for Continuously Supported Applications

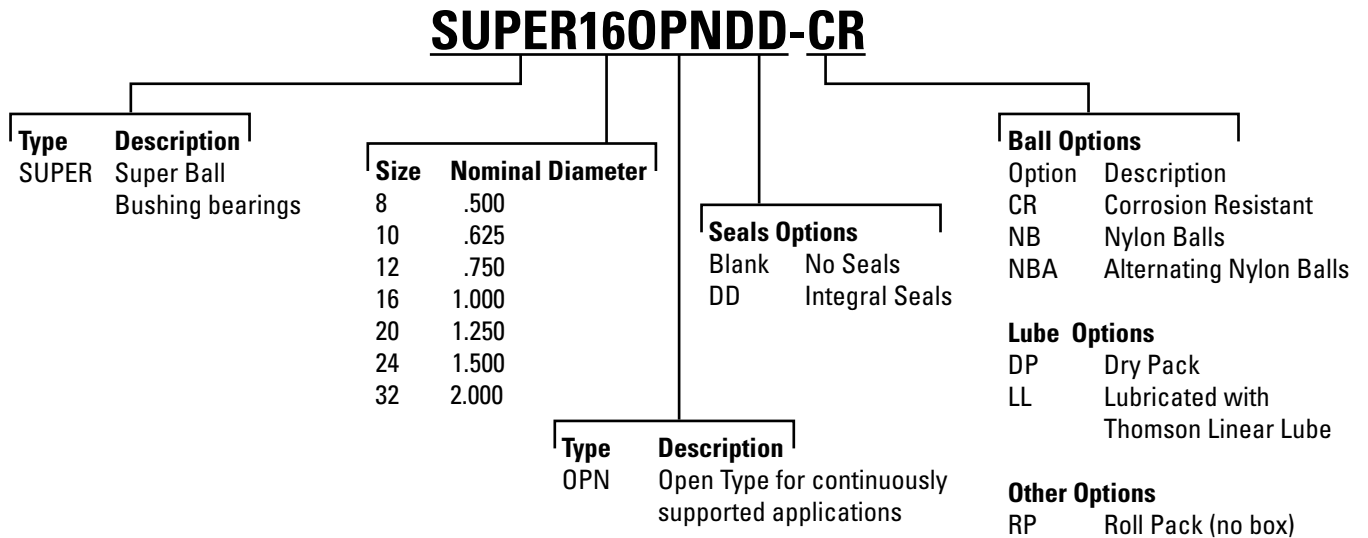

Super Ball Bushing Pillow Blocks (Open Type) for Continuously Supported Applications

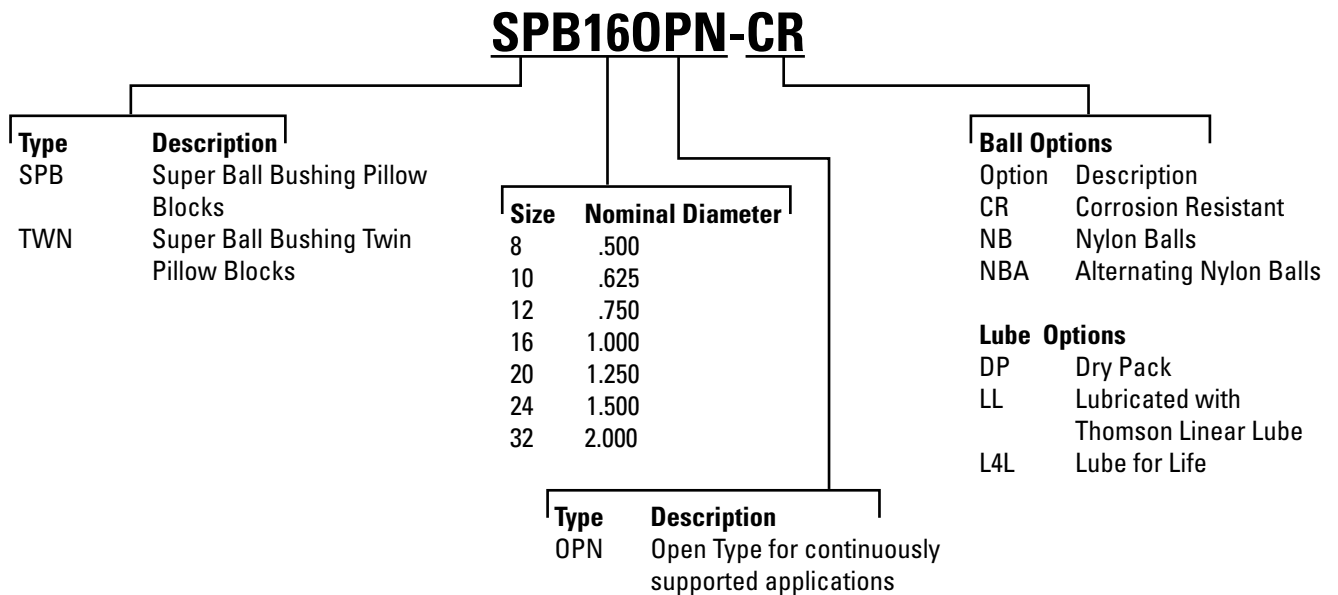

For addition information on bearing options see page 273.

Inch – Super Ball Bushing Bearings

Super Ball Bushing Bearings (Open Type) for Continuously Supported Applications

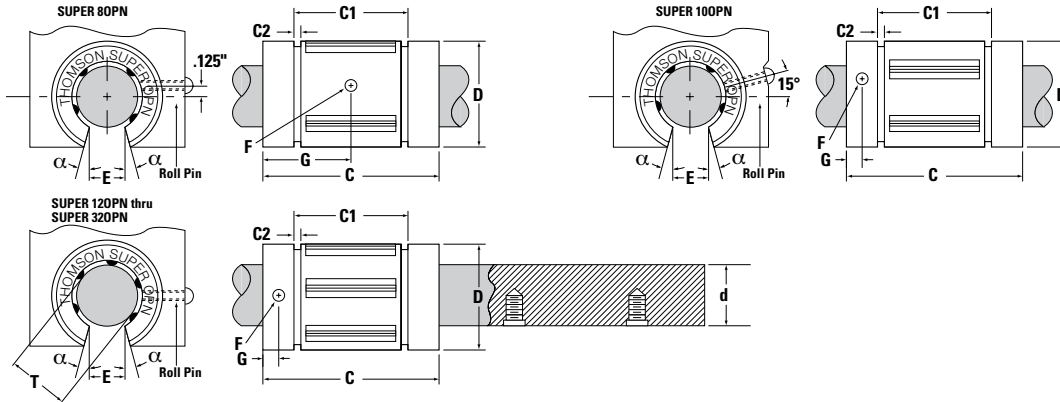
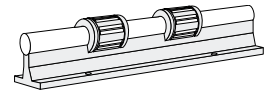

Super Ball Bushing Bearings (Open Type) and 60 Case LinearRace (Dimensions in inches)

Part Number ⁽³⁾		Nominal Diameter	Length C	Distance Between Retaining Rings C1	Ret. Ring Groove min. C2	Min. Slot Width E	Retention Hole		Angle deg α	Number of Ball Circuits	Ball Bushing Bearing Mass lb
Ball Bushing Bearing	60 Case LinearRace*						Dia. F	Loc. G			
SUPER80PN	1/2 L PD	.500	1.250/1.230	1.032/1.012	.050	.31	.14	.63	15	4	.04
SUPER100PN	5/8 L PD	.625	1.500/1.480	1.105/1.095	.056	.37	.11	.13	15	4	.08
SUPER120PN	3/4 L PD	.750	1.625/1.605	1.270/1.250	.056	.43	.14	.13	15	5	.12
SUPER160PN	1 L PD	1.000	2.250/2.230	1.884/1.864	.070	.56	.14	.13	15	5	.21
SUPER200PN	1 1/4 L PD	1.250	2.625/2.600	2.004/1.984	.068	.62	.20	.19	15	5	.38
SUPER240PN	1 1/2 L PD	1.500	3.000/2.970	2.410/2.390	.086	.75	.20	.19	15	5	.71
SUPER320PN	2 L PD	2.000	4.000/3.960	3.193/3.163	.105	1.00	.27	.31	15	5	1.20

* 60 Case begins on page 170.

Part Number ⁽³⁾	Working Bore Diameter T	Recommended Housing Bore Dia.		60 Case LinearRace Diameter d	Ball Bushing Bearing/LinearRace Fit Up \pm		Dynamic ^(2,*) Load Capacity lb _f
		Fixed D	Adjustable D		Fixed Diameter Housing	Adjustable Diameter Housing (Before Adjustment)	
SUPER80PN	.5000/.4995	.8755/.8750	.8760/.8750	.4995/.4990	.0015C/.0000	.002C/.0000	230
SUPER100PN	.6250/.6245	1.1255/1.1250	1.1260/1.1250	.6245/.6240	.0015C/.0000	.002C/.0000	320
SUPER120PN	.7500/.7495	1.2505/1.2500	1.2510/1.2500	.7495/.7490	.0015C/.0000	.002C/.0000	470
SUPER160PN	1.0000/.9995	1.5630/1.5625	1.5635/1.5625	.9995/.9990	.0015C/.0000	.002C/.0000	780
SUPER200PN	1.2500/1.2494	2.0008/2.0000	2.0010/2.0000	1.2495/1.2490	.0018C/.0001P	.002C/.0001P	1170
SUPER240PN	1.5000/1.4994	2.3760/2.3750	2.3760/2.3750	1.4994/1.4989	.0021C/.0000	.0021C/.0000	1560
SUPER320PN	2.000/1.9992	3.0010/3.0000	3.0010/3.0000	1.9994/1.9987	.0023C/.0002P	.0023C/.0002P	2350

‡ P = Preload, C = Clearance

(1) The Dynamic Load Capacity is based on a rated travel life of 2 million inches. The actual Dynamic Load Capacity can be affected by the orientation of the bearing or the direction of the applied load. For dynamic load correction factors see polar graphs below.

(3) For part number description and specifications see page 59.

Note: For additional technical information, see the Engineering section beginning on page 262.

Inch – Super Ball Bushing Bearings

Load/Life Graph

(Lines indicate limiting load for given Ball Bushing Pillow Block)

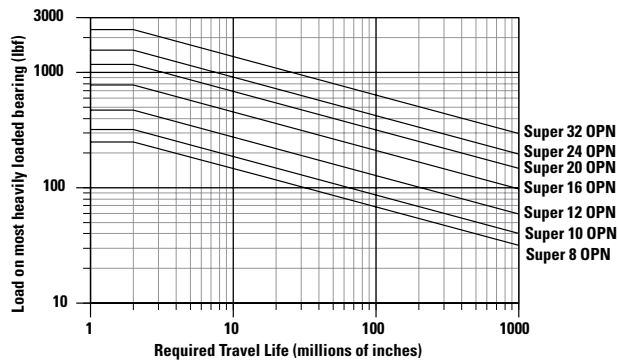

Determining Ball Bushing bearing Size

To determine the proper Ball Bushing bearing size enter the chart with the maximum load of the most heavily loaded bearing and the required travel life. Mark where the two lines intersect. All Ball Bushing bearing sizes that pass through or above and to the right of this point may be suitable for this application.

Note: For the purpose of using this chart.

Load on most heavily loaded bearing = maximum applied load/ K_0 .

Where K_0 can be determined from the Polar Graph to the right.

Polar Graphs

The actual Dynamic Load Capacity of a Ball Bushing bearing is determined by the orientation of the bearing or direction of the applied load. The load Correction Factor K_0 is found by knowing the direction of the applied load relative to the orientation of the bearings ball tracks and referring to the polar graph. To determine the actual Dynamic Load Capacity, multiply the proper correction factor by the Dynamic Load Capacity listed in the product table on the previous page.

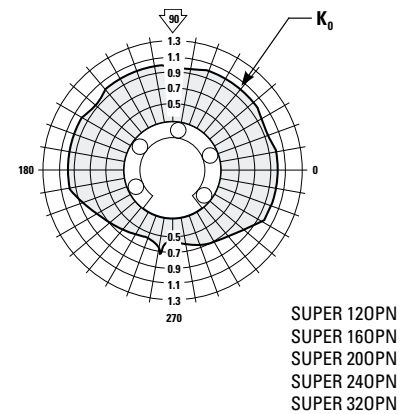
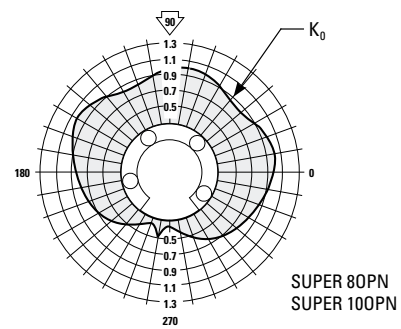

Inch – Super Ball Bushing Bearings

Sealed Super Ball Bushing Bearings (Open Type) for Continuously Supported Applications

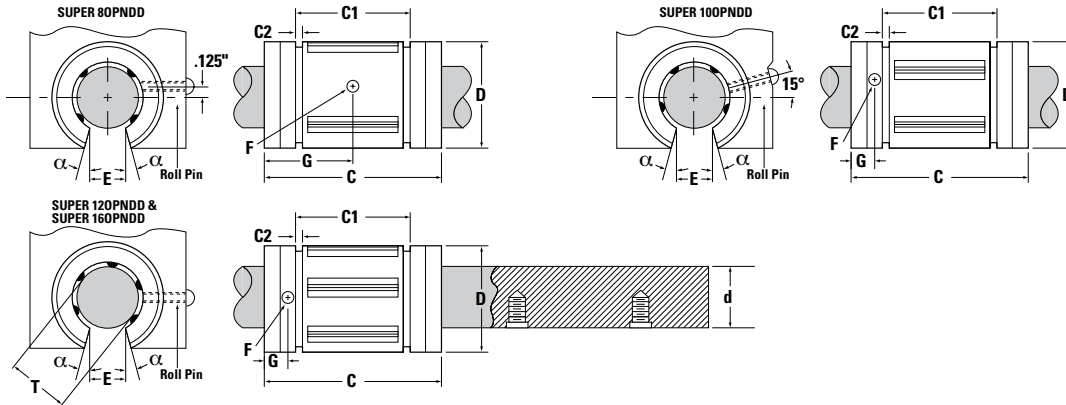
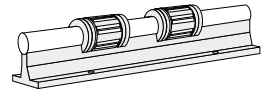

Sealed Super Ball Bushing Bearings (Open Type, seal at both ends) and 60 Case LinearRace (Dimensions in inches)

Part Number ⁽³⁾		Nom. Dia.	Length C	Distance Between Retaining Rings C1	Ret. Ring Groove min. C2	Min. Slot Width E	Retention Hole		Angle deg α	Number of Ball Circuits	Ball Bushings Mass lb
Ball Bushing Bearing	60 Case LinearRace*						Dia. F	Loc. G			
SUPER 80PNDD	1/2 L PD	.500	1.500/1.460	1.032/1.012	.050	.31	.14	.750	15	4	.03
SUPER 100PNDD	5/8 L PD	.625	1.750/1.710	1.105/1.095	.056	.37	.11	.250	15	4	.08
SUPER 120PNDD	3/4 L PD	.750	1.875/1.835	1.270/1.250	.056	.43	.14	.250	15	5	.12
SUPER 160PNDD	1 L PD	1.000	2.625/2.585	1.884/1.864	.070	.56	.14	.313	15	5	.21

* 60 Case begins on page 170.

Part Number ⁽³⁾	Working Bore Diameter T	Recommended Housing Bore Dia.		60 Case LinearRace Diameter d	Ball Bushing Bearing/LinearRace Fit Up †		Dynamic ^(2,*) Load Capacity lb _i
		Fixed D	Adjustable D		Fixed Diameter Housing	Adjustable Diameter Housing (Before Adjustment)	
SUPER 80PNDD	.5000/.4995	.8755/.8750	.8760/.8750	.4995/.4990	.0015C/.0000	.002C/.0000	230
SUPER 100PNDD	.6250/.6245	1.1255/1.1250	1.1260/1.1250	.6245/.6240	.0015C/.0000	.002C/.0000	320
SUPER 120PNDD	.7500/.7495	1.2505/1.2500	1.2510/1.2500	.7495/.7490	.0015C/.0000	.002C/.0000	470
SUPER 160PNDD	1.0000/.9995	1.5630/1.5625	1.5635/1.5625	.9995/.9990	.0015C/.0000	.002C/.0000	780

† P = Preload, C = Clearance

(1) The Dynamic Load Capacity is based on a rated travel life of 2 million inches. The actual Dynamic Load Capacity can be affected by the orientation of the bearing or the direction of the applied load. For dynamic load correction factors see polar graphs below.

(3) For part number description and specifications see page 59.

Note: For additional technical information, see the Engineering section beginning on page 262.

Inch – Super Ball Bushing Bearings

Load/Life Graph

(Lines indicate limiting load for given Ball Bushing Pillow Block)

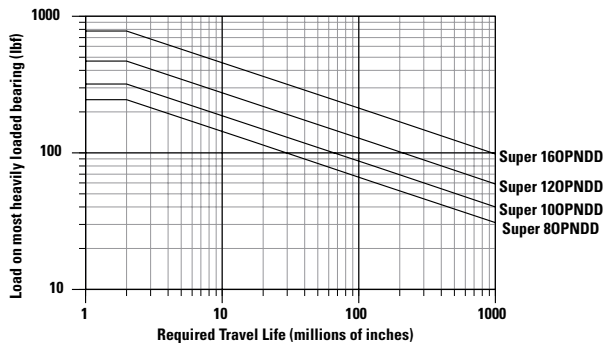

Determining Ball Bushing bearing Size

To determine the proper Ball Bushing bearing size enter the chart with the maximum load of the most heavily loaded bearing and the required travel life. Mark where the two lines intersect. All Ball Bushing bearing sizes that pass through or above and to the right of this point may be suitable for this application.

Note: For the purpose of using this chart.

Load on most heavily loaded bearing = maximum applied load/ K_0 .

Where K_0 can be determined from the Polar Graph to the right.

Polar Graphs

The actual Dynamic Load Capacity of a Ball Bushing bearing is determined by the orientation of the bearing or direction of the applied load. The load Correction Factor K_0 is found by knowing the direction of the applied load relative to the orientation of the bearings ball tracks and referring to the polar graph. To determine the actual Dynamic Load Capacity, multiply the proper correction factor by the Dynamic Load Capacity listed in the product table on the previous page.

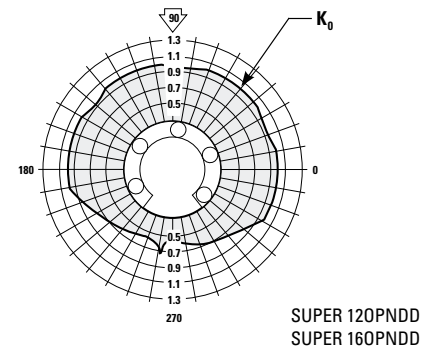
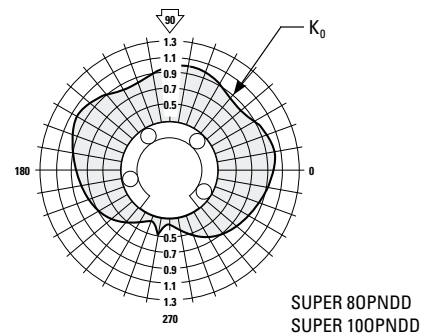

Inch – Super Ball Bushing Bearings

Super Ball Bushing Pillow Blocks (Open Type) for Continuously Supported Applications

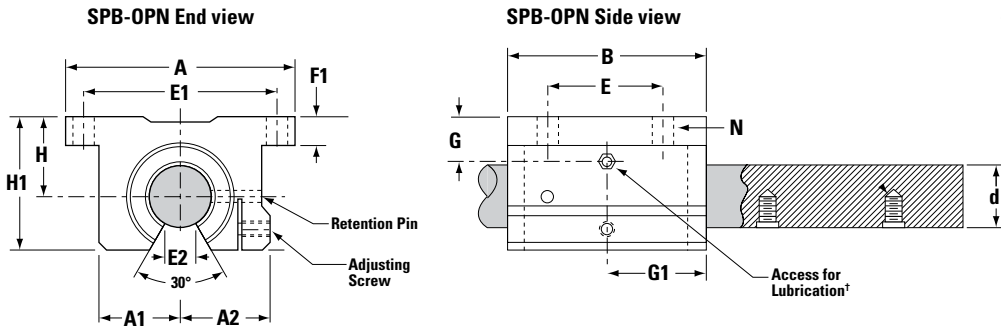
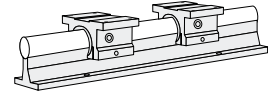

† Size .500 has oil lubricant fitting. Sizes .625 and above have 1/4-28 access for lubrication.

Super Ball Bushing Pillow Blocks (Open Type, seal at both ends) and 60 Case LinearRace (Dimensions in inches)

Part Number ⁽³⁾		Nominal Diameter	H ±.003	H1	A	A1	A2	B
Super Ball Bushing Pillow Block	60 Case LinearRace*							
SPB80PN	1/2 L PD	.500	.687	1.13	2.00	.69	.75	1.50
SPB100PN	5/8 L PD	.625	.875	1.44	2.50	.88	.94	1.75
SPB120PN	3/4 L PD	.750	.937	1.56	2.75	.94	1.00	1.88
SPB160PN	1 L PD	1.000	1.187	2.00	3.25	1.19	1.25	2.63
SPB200PN	1 1/4 L PD	1.250	1.500	2.56	4.00	1.50	1.63	3.38
SPB240PN	1 1/2 L PD	1.500	1.750	2.94	4.75	1.75	1.88	3.75
SPB320PN	2 L PD	2.000	2.125	3.63	6.00	2.25	2.44	4.75

* 60 Case begins on page 170.

Part Number ⁽³⁾	60 Case LinearRace Diameter d	E ±.010	E1 ±.010	E2 Min.	F1	G	G1	N		Pillow Block Mass lb	Dynamic ⁽¹⁾ Load Capacity lb _f
								Hole	Bolt		
SPB80PN	.4995/.4990	1.000	1.688	.31	.25	.50	.89	.16	#6	.2	230
SPB100PN	.6245/.6240	1.125	2.125	.37	.28	.55	.95	.19	#8	.4	320
SPB120PN	.7495/.7490	1.250	2.375	.43	.31	.67	1.08	.19	#8	.5	470
SPB160PN	.9995/.9990	1.750	2.875	.56	.38	.87	1.45	.22	#10	1.0	780
SPB200PN	1.2495/1.2490	2.000	3.500	.62	.44	1.15	1.83	.22	#10	2.1	1170
SPB240PN	1.4994/1.4989	2.500	4.125	.75	.50	1.28	2.02	.28	.25	3.2	1560
SPB320PN	1.9994/1.9987	3.250	5.250	1.00	.63	1.55	3.19	.41	.38	6.0	2350

(1) The Dynamic Load Capacity is based on a rated travel life of 2 million inches. The actual Dynamic Load Capacity can be affected by the orientation of the bearing or the direction of the applied load. For dynamic load correction factors see polar graphs below.

(3) For part number description and specifications see page 59.

Note: For additional technical information, see the Engineering section beginning on page 262.

Inch – Super Ball Bushing Bearings

Load/Life Graph

(Lines indicate limiting load for given Ball Bushing Pillow Block)

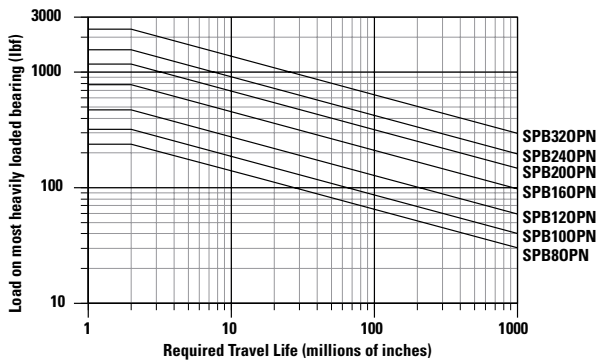

Determining Ball Bushing bearing Size

To determine the proper Ball Bushing bearing size enter the chart with the maximum load of the most heavily loaded bearing and the required travel life. Mark where the two lines intersect. All Ball Bushing bearing sizes that pass through or above and to the right of this point may be suitable for this application.

Note: For the purpose of using this chart.

Load on most heavily loaded bearing = maximum applied load/ K_0 .

Where K_0 can be determined from the Polar Graph to the right.

Polar Graphs

The actual Dynamic Load Capacity of a Ball Bushing bearing is determined by the orientation of the bearing or direction of the applied load. The load Correction Factor K_0 is found by knowing the direction of the applied load relative to the orientation of the bearings ball tracks and referring to the polar graph. To determine the actual Dynamic Load Capacity, multiply the proper correction factor by the Dynamic Load Capacity listed in the product table on the previous page.

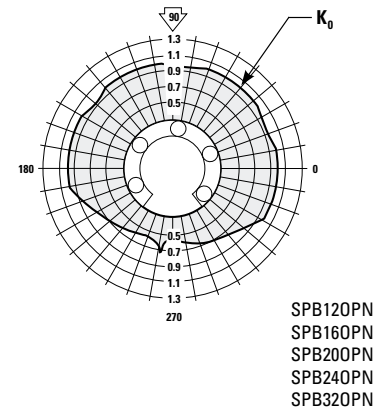
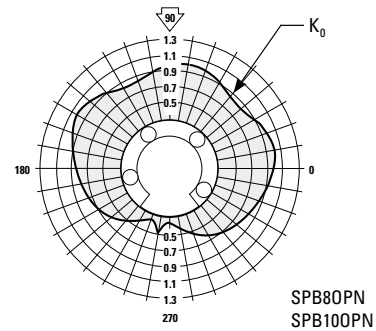

Inch – Super Ball Bushing Bearings

Super Ball Bushing Twin Pillow Blocks (Open Type) for Continuously Supported Applications

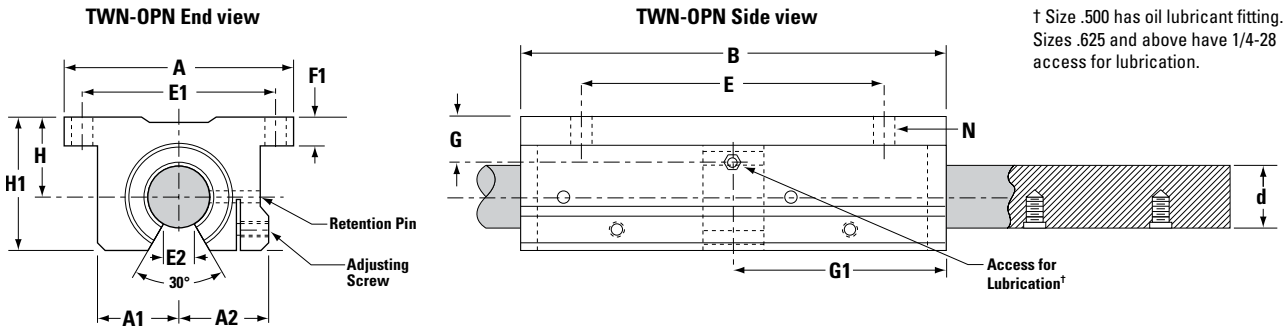
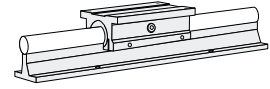

Super Ball Bushing Twin Pillow Blocks (Open Type, seal at both ends) and 60 Case LinearRace (Dimensions in inches)

Part Number ⁽³⁾		Nominal Diameter	H ±.003	H1	A	A1	A2	B
Super Ball Bushing Twin Pillow Block	60 Case LinearRace*							
TWN80PN	1/2 L PD	.500	.687	1.13	2.00	.69	.75	3.50
TWN100PN	5/8 L PD	.625	.875	1.44	2.50	.88	.94	4.00
TWN120PN	3/4 L PD	.750	.937	1.56	2.75	.94	1.00	4.50
TWN160PN	1 L PD	1.000	1.187	2.00	3.25	1.19	1.25	6.00
TWN200PN	1 1/4 L PD	1.250	1.500	2.56	4.00	1.50	1.63	7.50
TWN240PN	1 1/2 L PD	1.500	1.750	2.94	4.75	1.75	1.88	9.00

* 60 Case begins on page 170.

Part Number ⁽³⁾	60 Case LinearRace Diameter d	E ±.010	E1 ±.010	E2 Min.	F1	G	G1	N		Pillow Block Mass lb	Dynamic ⁽¹⁾ Load Capacity lb _i
								Hole	Bolt		
TWN80PN	.4995/.4990	2.500	1.688	.31	.25	.56	1.75	.16	#6	.4	460
TWN100PN	.6245/.6240	3.000	2.125	.37	.28	.67	2.00	.19	#8	.8	640
TWN120PN	.7495/.7490	3.500	2.375	.43	.31	.94	2.25	.19	#8	1.0	940
TWN160PN	.9995/.9990	4.500	2.875	.56	.38	1.20	3.00	.22	#10	2.0	1560
TWN200PN	1.2495/1.2490	5.500	3.500	.62	.44	1.50	3.75	.22	#10	4.2	2340
TWN240PN	1.4994/1.4989	6.500	4.125	.75	.50	1.75	4.50	.28	.25	6.7	3120

(1) The Dynamic Load Capacity is based on a rated travel life of 2 million inches. The actual Dynamic Load Capacity can be affected by the orientation of the bearing or the direction of the applied load. For dynamic load correction factors see polar graphs below.

(3) For part number description and specifications see page 59.

Note: For additional technical information, see the Engineering section beginning on page 262.

Inch – Super Ball Bushing Bearings

Load/Life Graph

(Lines indicate limiting load for given Ball Bushing Pillow Block)

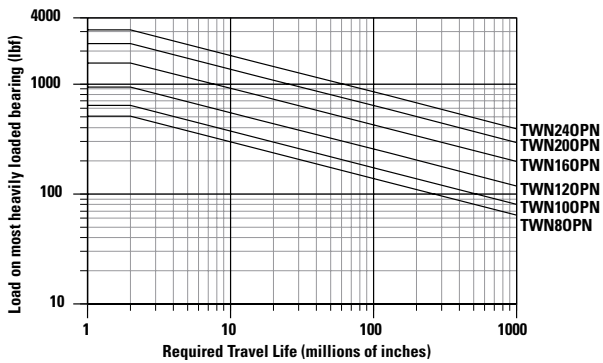

Determining Ball Bushing bearing Size

To determine the proper Ball Bushing bearing size enter the chart with the maximum load of the most heavily loaded bearing and the required travel life. Mark where the two lines intersect. All Ball Bushing bearing sizes that pass through or above and to the right of this point may be suitable for this application.

Note: For the purpose of using this chart.

Load on most heavily loaded bearing = maximum applied load/ K_0 .

Where K_0 can be determined from the Polar Graph to the right.

Polar Graphs

The actual Dynamic Load Capacity of a Ball Bushing bearing is determined by the orientation of the bearing or direction of the applied load. The load Correction Factor K_0 is found by knowing the direction of the applied load relative to the orientation of the bearings ball tracks and referring to the polar graph. To determine the actual Dynamic Load Capacity, multiply the proper correction factor by the Dynamic Load Capacity listed in the product table on the previous page.

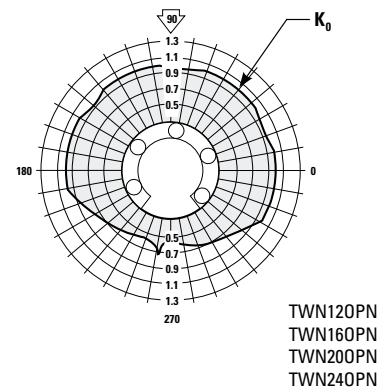
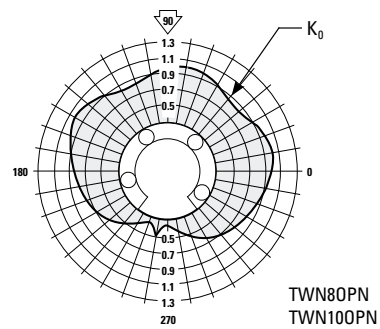

Inch – Super Ball Bushing Bearings

Cam-Actuated Part Transfer Mechanism for Multiple-Transfer Press

Objective

Improve production rate and increase the service life of a transfer table mechanism.

Solution

Replace the conventional linear bearings with Adjustable Super Ball Bushing Twin Pillow Blocks. Bearing service life increased to 5 years.

Products Specified

2 - TWN16-ADJ (Super Ball Bushing Twin Pillow Blocks)
4 - ASB16 (60 Case LinearRace End Support Blocks)
2 - 1 L CTL x 24.00 in (60 Case LinearRace)

Benefits

The table achieved maximum cycle efficiency by reducing costly downtime and improving service life.

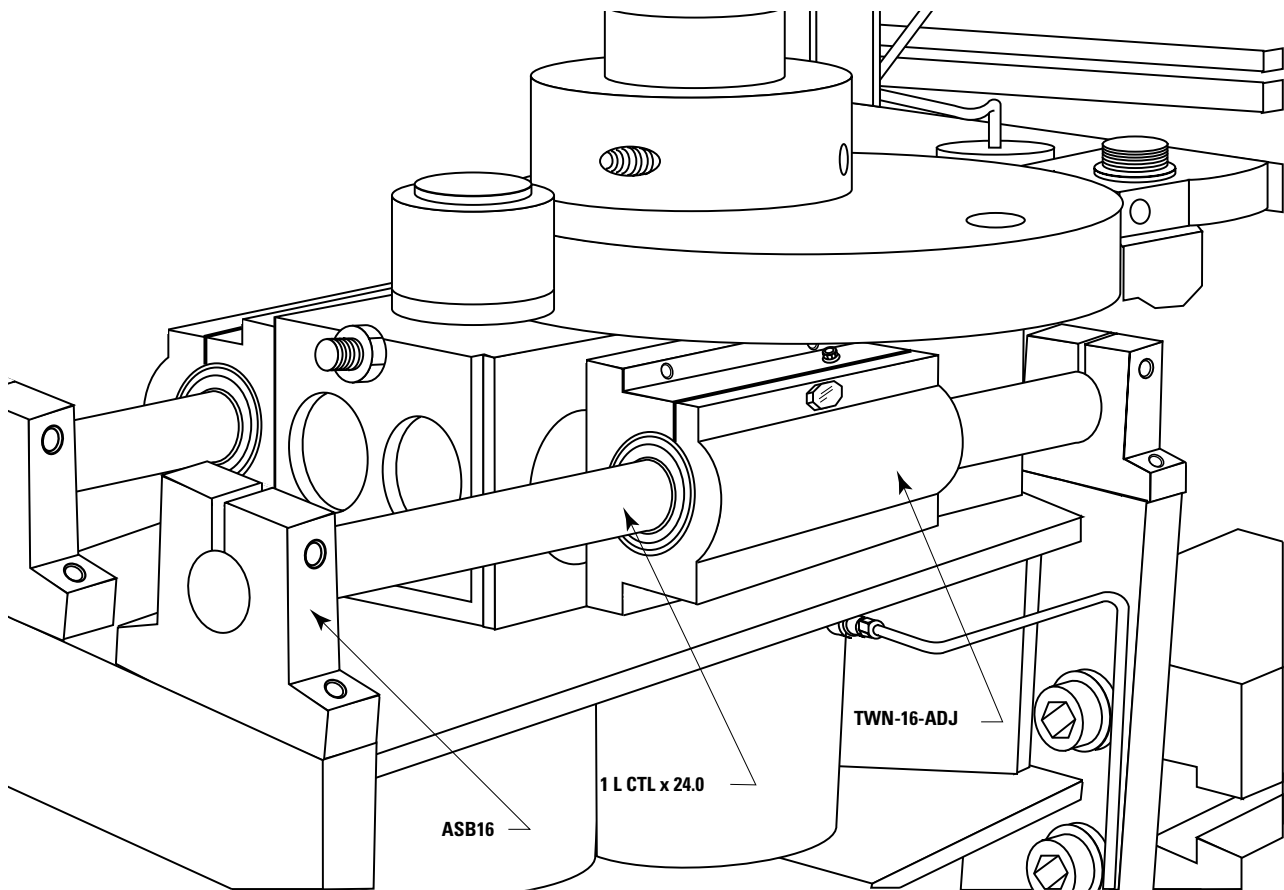

Inch – Precision Steel Ball Bushing Bearings

Precision Steel Ball Bushing Bearing Products

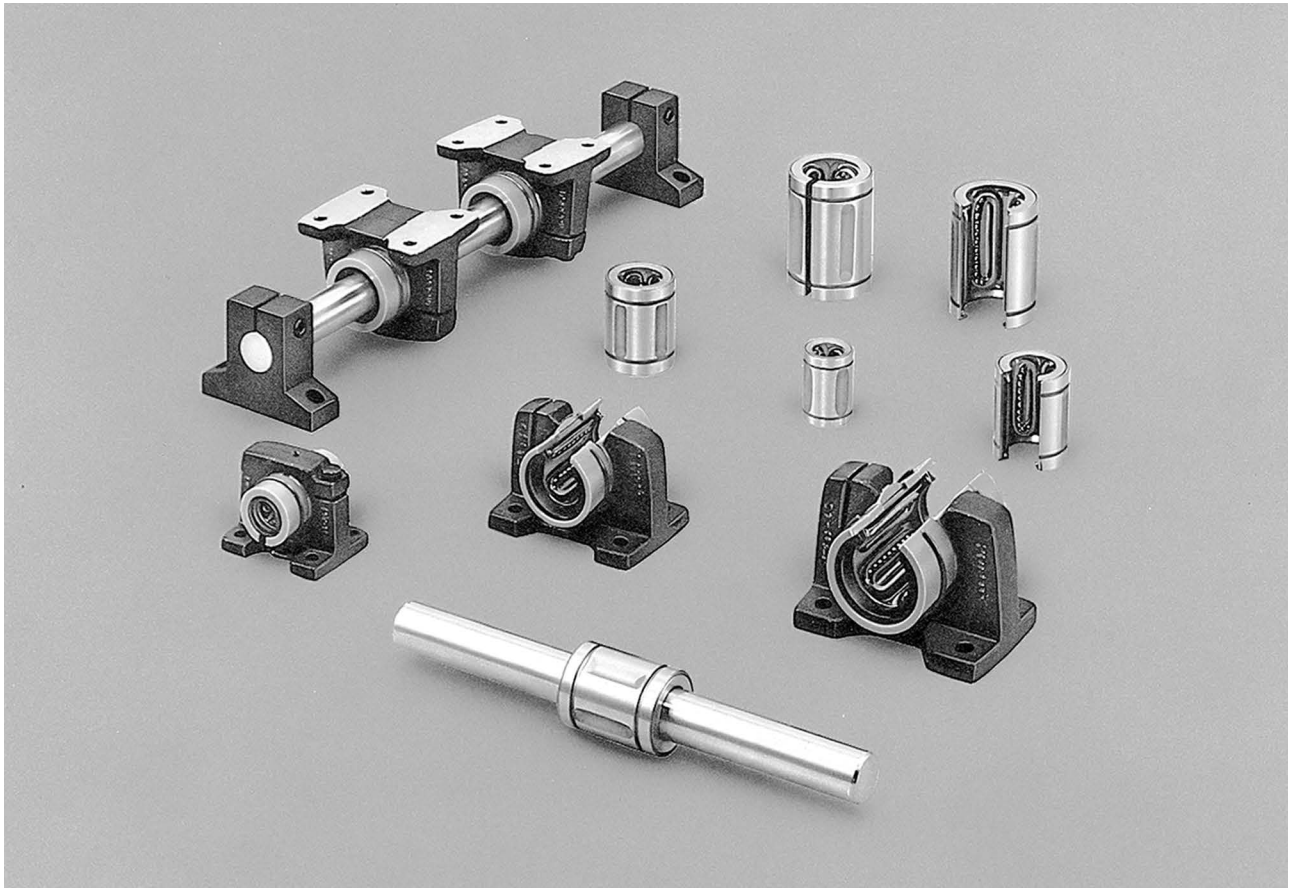

Thomson Precision Steel Ball Bushing Bearing Products offer:

- A coefficient of friction as low as .001. When replacing high friction plain bearings, Precision Steel Ball Bushing Bearings dramatically improve machine productivity and efficiency.
- All-steel construction, for maximum system rigidity.
- Two accuracy classes allowing for immediate improvements in system positioning and repeatability.
- Availability in fourteen bore sizes and nine configurations.
- The RoundRail Advantage which minimizes installation time and cost.
- Steady state travel speeds up to 10 ft/s and accelerations to 450 ft/s² without the use of derating factors.
- An operating temperature up to 600° F / 315° C.
- Availability in a self-aligning pillow block housing for ease of installation and use.
- Worldwide availability from over 1800 authorized distributors.

Inch – Precision Steel Ball Bushing Bearings

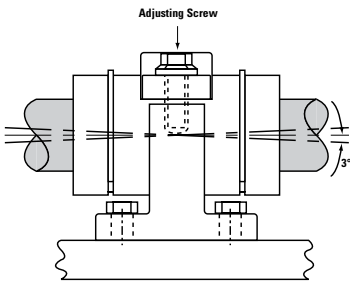

Figure 1

When the Precision Steel Ball Bushing Bearing is installed in its standard Pillow Block it will self-align up to 3 degrees in all directions.

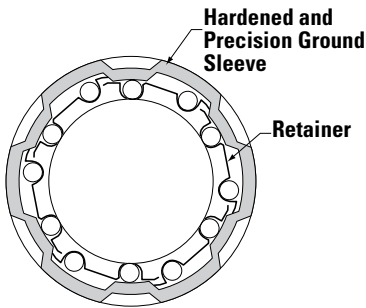

Figure 2

Precision Steel Ball Bushing Bearing Cross-section

The basis for the performance of all Precision Steel Ball Bushing Bearings is a simple but ingenious system of ball recirculation that permits almost frictionless, unlimited travel.

Replace High Friction Plain Bearings

Plain bearings cause friction, stick-slip, binding and chatter. The Precision Steel Ball Bushing Bearing's patented ball recirculation virtually eliminates wear and provides a constant coefficient of friction as low as .001. This dramatic reduction in friction allows the designer to use smaller less expensive drive motors, ball screws, belts, linkages and gears.

Lasting Precision Alignment

High friction plain bearings cause wear resulting in a loss in system alignment and repeatability. Each Precision Steel Ball Bushing Bearing is manufactured with high quality bearing steel that is hardened and precision ground. The rolling elements of each Ball Bushing Bearing are precision ground bearing balls that recirculate freely into and out of the load zone. The balls are guided through their recirculation path by a steel retainer and hardened sleeve. The inherent non-wear characteristics of each Precision Steel Ball Bushing Bearing assures maximum system accuracy and repeatability.

High Travel Speeds

Precision Steel Ball Bushing can operate at travel rates as high as 10 ft/s and accelerations as high as 450 ft/s². When replacing inefficient v-way or flat-way systems, this travel rate capability provides immediate improvements in machine efficiency and productivity.

Ease of Installation

The Precision Steel Ball Bushing Bearing can be retained in a housing, internally or externally. The retaining ring groove on the outside diameter allows the bearing to be captured and retained by an external retaining ring. If internal retention is required, the Ball Bushing Bearing can be installed in a housing and held in place with an internal retaining ring.

Protection from Contamination

Precision Steel Ball Bushing Bearings most popular sizes are available with double acting integral wipers that keep out contamination, retain lubrication and maximize travel life.

Inch – Precision Steel Ball Bushing Bearings

Part Number Description and Specification

Precision Steel Ball Bushing Bearings (Closed Type) for End Supported Applications

A162536DD-SP

Type	Description	Size	Nom. Dia.	Seals Options	Ball Options
A	Precision Steel Ball Bushing Bearings	4812	.250	Blank No Seals DD Integral Seals	Option Description SS Stainless Steel (up to and including 1")
XA	Extra Precision Ball Bushing Bearings	81420	.500		SP Stainless Steel Balls, Black Oxide Retainer and Sleeve
ADJ	Adjustable Precision Steel Ball Bushing bearings	122026	.750		NB Nylon Balls
		162536	1.000		NBA Alternating Nylon Balls
		203242	1.250		
		243848	1.500		
		324864	2.000		
		406080	2.500		
		487296	3.000		
6496128	4.000				
				Lube Options	DP Dry Pack LL Lubricated with Thomson Linear Lube
				Other Options	RP Roll Pack (no box)

Precision Steel Ball Bushing Pillow Blocks (Closed Type) for End Supported Applications

PB16ADJ-SS

Type	Description	Size	Nominal Diameter	Type	Description	Ball Options
PB	Precision Steel Ball Bushing Pillow Blocks	8	.500	A Standard ADJ Adjustable Type		Option Description SS Stainless Steel
		12	.750			SP Stainless Steel Balls, Black Oxide Retainer and Sleeve
		16	1.000			NB Nylon Balls
		20	1.250			NBA Alternating Nylon Balls
		24	1.500			
		32	2.000			
				Lube Options	DP Dry Pack LL Lubricated with Thomson Linear Lube	
				Other Options	HP Black Oxide	

For addition information on bearing options see page 273.

Inch – Precision Steel Ball Bushing Bearings

Precision Steel Ball Bushing Bearings (Closed Type) for End Supported Applications

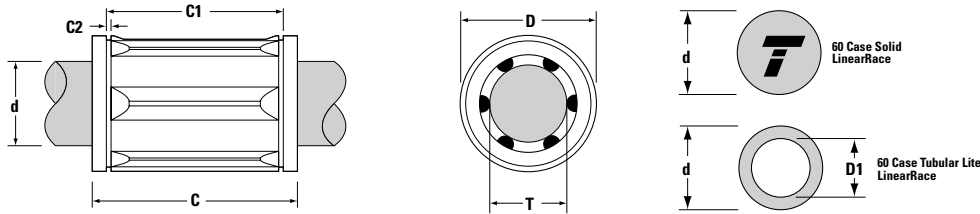
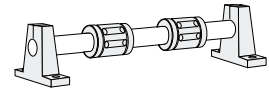

Sizes .250 thru 1.00 available in
Corrosion Resistant Stainless Steel

Precision Steel Ball Bushing Bearings (Closed Type) and 60 Case LinearRace (Dimensions in inches)

Part Number ⁽²⁾		60 Case Linear Race	Nominal Diameter	Length C	Distance Between Retaining Grooves C1	Retaining Ring Groove min. C2	Number of Ball Circuits	D	60 Case Solid LinearRace Mass lb/in	60 Case Tubular Lite LinearRace Mass lb/in	60 Case Tubular Lite LinearRace ID D1
Precision Steel Ball Bushing Bearings	w/o Seals										
A4812	–	1/4 S	.250	.750/.735	.515/.499	.039	3	.5000/.4996	.01	–	–
A61014	–	3/8 S	.375	.875/.860	.640/.624	.039	4	.6250/.6246	.03	–	–
A81420	A81420DD	1/2 S	.500	1.250/1.235	.967/.951	.046	4	.8750/.8746	.06	–	–
A101824	–	5/8 S	.625	1.500/1.485	1.108/1.092	.056	4	1.1250/1.1246	.09	–	–
A122026	A122026DD	3/4 S	.750	1.625/1.610	1.170/1.154	.056	5	1.2500/1.2496	.13	.08	.46/.41
A162536	A162536DD	1 S	1.000	2.250/2.235	1.759/1.741	.068	5	1.5625/1.5621	.22	.16	.62/.56
A203242	–	1 1/4 S	1.250	2.625/2.605	2.009/1.991	.068	6	2.0000/1.9995	.35	–	–
A243848	–	1 1/2 S	1.500	3.000/2.980	2.415/2.397	.086	6	2.3750/2.3745	.50	.33	.93/.84
A324864	–	2 S	2.000	4.000/3.980	3.195/3.177	.103	6	3.0000/2.9994	.89	.54	1.31/1.18
A406080	–	2 1/2 S	2.500	5.000/4.975	3.978/3.958	.120	6	3.7500/3.7492	1.39	.75	1.84/1.66
A487296	–	3 S	3.000	6.000/5.970	4.728/4.708	.120	6	4.5000/4.4990	2.00	1.11	2.20/1.80
A6496128	–	4 S	4.000	8.000/7.960	6.265/6.235	.139	6	6.0000/5.9988	3.56	1.56	3.30/2.70

Part Number ⁽²⁾		Working Bore Diameter T	Recommended Housing Bore		60 Case LinearRace Diameter d	Precision Steel Ball Bushing Bearing/ LinearRace Fit Up †	Precision Steel Ball Bushing Bearing Mass lb	Dynamic ⁽¹⁾ Load Capacity lb _i
Precision Steel Ball Bushing Bearings	w/o Seals		Normal Fit	Press Fit				
A4812	–	.2500/.2495	.5005/.5000	.4995/.4990	.2490/.2485	.0015C/.0005C	.02	19
A61014	–	.3750/.3745	.6255/.6250	.6245/.6240	.3740/.3735	.0015C/.0005C	.06	37
A81420	A81420DD	.5000/.4995	.8755/.8750	.8745/.8740	.4990/.4985	.0015C/.0005C	.08	85
A101824	–	.6250/.6245	1.1255/1.1250	1.1245/1.1240	.6240/.6235	.0015C/.0005C	.16	150
A122026	A122026DD	.7500/.7495	1.2505/1.2500	1.2495/1.2490	.7490/.7485	.0015C/.0005C	.21	200
A162536	A162536DD	1.0000/.9995	1.5630/1.5625	1.5620/1.5615	.9990/.9985	.0015C/.0005C	.38	350
A203242	–	1.2500/1.2494	2.0010/2.0000	1.9993/1.9983	1.2490/1.2485	.0015C/.0004C	1.10	520
A243848	–	1.5000/1.4994	2.3760/2.3750	2.3743/2.3733	1.4989/1.4984	.0016C/.0005C	1.43	770
A324864	–	2.0000/1.9992	3.0010/3.0000	2.9992/2.9982	1.9987/1.9980	.0020C/.0005C	2.75	1100
A406080	–	2.5000/2.4990	3.7510/3.7500	Not Normally Recommended	2.4985/2.4977	.0023C/.0005C	5.50	1800
A487296	–	3.0000/2.9988	4.5010/4.5000		2.9983/2.9974	.0026C/.0005C	9.50	2600
A6496128	–	4.0000/3.9980	6.0010/6.0000		3.9976/3.9964	.0036C/.0004C	20.20	5000

† P = Preload, C = Clearance

⁽¹⁾ The Dynamic Load Capacity is based on a rated travel life of 2 million inches.

The actual Dynamic Load Capacity can be affected by the orientation of the bearing or the direction of the applied load. For dynamic load correction factors see polar graphs below.

⁽²⁾ For part number description and specifications see page 71.

Note: Precision Steel Ball Bushing Bearings are available in corrosion resistant stainless steel in diameters up to 1 inch. Dynamic load ratings are reduced by 30% when using stainless steel Ball Bushing Bearings. For additional technical information, see the Engineering section beginning on page 262.

Inch – Precision Steel Ball Bushing Bearings

Load/Life Graph

(Lines indicate limiting load for given Ball Bushing Bearing)

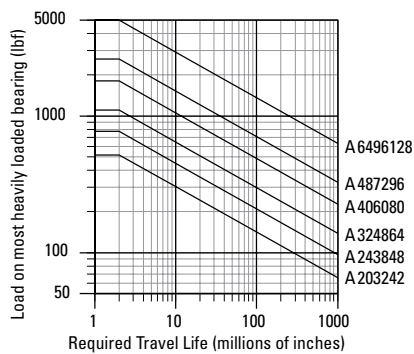
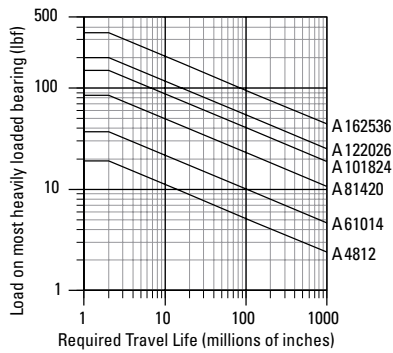

Determining Ball Bushing Bearing Size

To determine the proper Ball Bushing Bearing size enter the chart with the maximum load of the most heavily loaded bearing and the required travel life. Mark where the two lines intersect. All Ball Bushing Bearing sizes that pass through or above and to the right of this point may be suitable for this application.

Note: For the purpose of using this chart.

Load on most heavily loaded bearing = maximum applied load/ K_0 .

Where K_0 can be determined from the Polar Graph to the right.

Polar Graphs

The actual Dynamic Load Capacity of a Ball Bushing Bearing is determined by the orientation of the bearing or direction of the applied load. The load Correction Factor K_0 is found by knowing the direction of the applied load relative to the orientation of the bearings ball tracks and referring to the polar graph. To determine the actual Dynamic Load Capacity, multiply the proper correction factor by the Dynamic Load Capacity listed in the product table on the previous page.

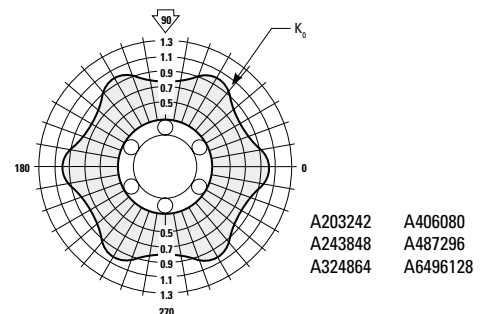
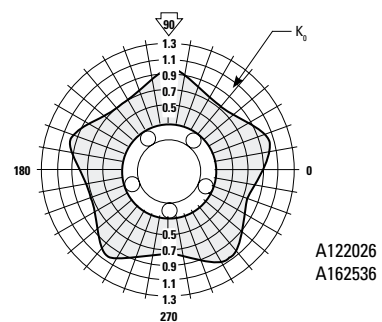
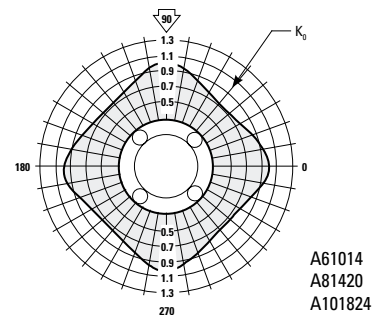
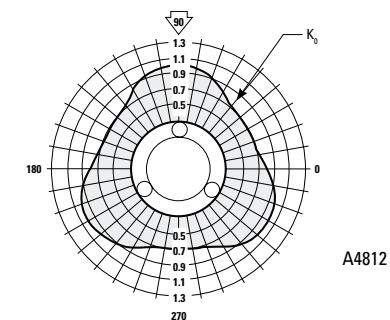

Inch – Precision Steel Ball Bushing Bearings

Extra Precision Steel Ball Bushing Bearings (Closed Type) for End Supported Applications

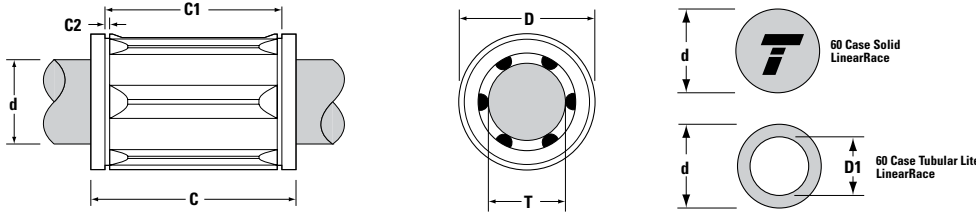
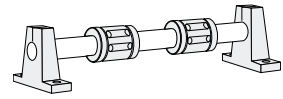

Sizes .250 thru 1.00 available in
Corrosion Resistant Stainless Steel

Extra Precision Steel Ball Bushing Bearings (Closed Type) and 60 Case LinearRace (Dimensions in inches)

Part Number ⁽²⁾		60 Case Linear Race	Nominal Diameter	Length C	Distance Between Retaining Grooves C1	Retaining Ring Groove min. C2	Number of Ball Circuits	D	60 Case Solid LinearRace Mass lb/in	60 Case Tubular Lite LinearRace Mass lb/in	60 Case Tubular Lite LinearRace ID D1
Extra Precision Steel Ball Bushing Bearing	w/o Wipers										
XA4812	–	1/4 L	.250	.750/.735	.515/.499	.039	3	.5000/.4996	.01	–	–
XA61014	–	3/8 L	.375	.875/.860	.640/.624	.039	4	.6250/.6246	.03	–	–
XA81420	XA81420DD	1/2 L	.500	1.250/1.235	.967/.951	.046	4	.8750/.8746	.06	–	–
XA101824	–	5/8 L	.625	1.500/1.485	1.108/1.092	.056	4	1.1250/1.1246	.09	–	–
XA122026	XA122026DD	3/4 L	.750	1.625/1.610	1.170/1.154	.056	5	1.2500/1.2496	.13	.08	.46/.41
XA162536	XA162536DD	1 L	1.000	2.250/2.235	1.759/1.741	.068	5	1.5625/1.5621	.22	.16	.62/.56
XA203242	–	1 1/4 L	1.250	2.625/2.605	2.009/1.991	.068	6	2.0000/1.9995	.35	–	–
XA243848	–	1 1/2 L	1.500	3.000/2.980	2.415/2.397	.086	6	2.3750/2.3745	.50	.33	.93/.84
XA324864	–	2 L	2.000	4.000/3.980	3.195/3.177	.103	6	3.0000/2.9994	.89	.54	1.31/1.18
XA406080	–	2 1/2 L	2.500	5.000/4.975	3.978/3.958	.120	6	3.7500/3.7492	1.39	.75	1.84/1.66
XA487296	–	3 L	3.000	6.000/5.970	4.728/4.708	.120	6	4.5000/4.4990	2.00	1.11	2.20/1.80
XA6496128	–	4 L	4.000	8.000/7.960	6.265/6.235	.139	6	6.0000/5.9988	3.56	1.56	3.30/2.70

Part Number ⁽²⁾		Working Bore Diameter T	Recommended Housing Bore		60 Case LinearRace Diameter d	Precision Steel Ball Bushing Bearing/LinearRace Fit Up ‡	Precision Steel Ball Bushing Bearing Mass lb	Dynamic ⁽¹⁾ Load Capacity lb _f
w/o Seals	with Seals		Normal Fit	Press Fit				
XA4812	–	.2500/.2497	.5005/.5000	Not Normally Recommended	.2495/.2490	.0010C/.0002C	.02	19
XA61014	–	.3750/.3747	.6255/.6250		.3745/.3740	.0010C/.0002C	.06	37
XA81420	XA81420DD	.5000/.4997	.8755/.8750		.4995/.4990	.0010C/.0002C	.08	85
XA101824	–	.6250/.6247	1.1255/1.1250		.6245/.6240	.0010C/.0002C	.16	150
XA122026	XA122026DD	.7500/.7497	1.2505/1.2500		.7495/.7490	.0010C/.0002C	.21	200
XA162536	XA162536DD	1.0000/.9997	1.5630/1.5625		.9995/.9990	.0010C/.0002C	.38	350
XA203242	–	1.2500/1.2496	2.0010/2.0000		1.2495/1.2490	.0010C/.0001C	1.10	520
XA243848	–	1.5000/1.4996	2.3760/2.3750		1.4994/1.4989	.0011C/.0002C	1.43	770
XA324864	–	2.0000/1.9996	3.0010/3.0000		1.9994/1.9987	.0013C/.0002C	2.75	1100
XA406080	–	2.5000/2.4995	3.7510/3.7500		2.4993/2.4985	.0015C/.0002C	5.50	1800
XA487296	–	3.0000/2.9994	4.5010/4.5000		2.9992/2.9983	.0017C/.0002C	9.50	2600
XA6496128	–	4.0000/3.9990	6.0010/6.0000		3.9988/3.9976	.0024C/.0002C	20.20	5000

‡ P = Preload, C = Clearance

(1) The Dynamic Load Capacity is based on a rated travel life of 2 million inches. The actual Dynamic Load Capacity can be affected by the orientation of the bearing or the direction of the applied load. For dynamic load correction factors see polar graphs below.

(2) For part number description and specifications see page 71.

Note: Precision Steel Ball Bushing Bearings are available in corrosion resistant stainless steel in diameters up to 1 inch. Dynamic load ratings are reduced by 30% when using stainless steel Ball Bushing Bearings. For additional technical information, see the Engineering section beginning on page 262.

Inch – Precision Steel Ball Bushing Bearings

Load/Life Graph

(Lines indicate limiting load for given Ball Bushing Bearing)

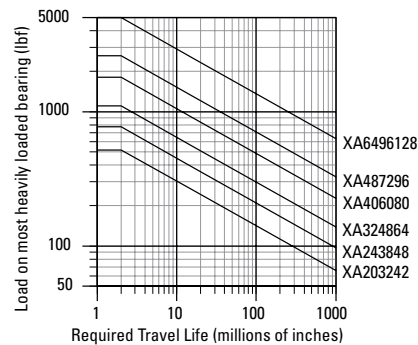
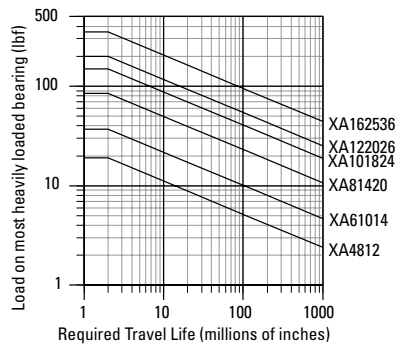

Determining Ball Bushing Bearing Size

To determine the proper Ball Bushing Bearing size enter the chart with the maximum load of the most heavily loaded bearing and the required travel life. Mark where the two lines intersect. All Ball Bushing Bearing sizes that pass through or above and to the right of this point may be suitable for this application.

Note: For the purpose of using this chart.

Load on most heavily loaded bearing = maximum applied load/ K_0 .

Where K_0 can be determined from the Polar Graph to the right.

Polar Graphs

The actual Dynamic Load Capacity of a Ball Bushing Bearing is determined by the orientation of the bearing or direction of the applied load. The load Correction Factor K_0 is found by knowing the direction of the applied load relative to the orientation of the bearings ball tracks and referring to the polar graph. To determine the actual Dynamic Load Capacity, multiply the proper correction factor by the Dynamic Load Capacity listed in the product table on the previous page.

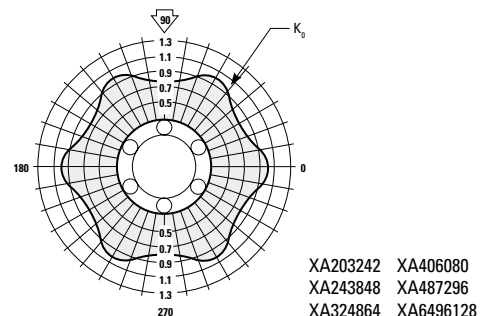
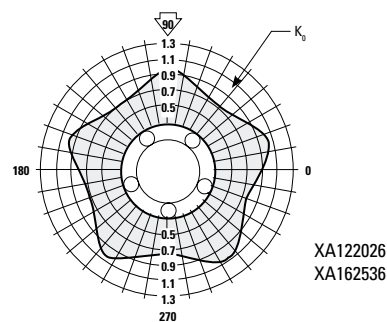
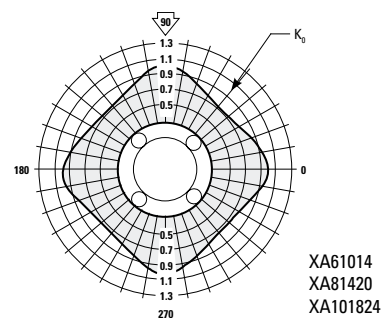
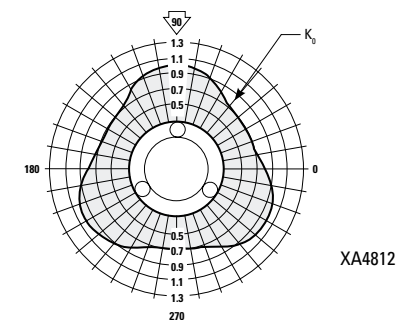

Inch – Precision Steel Ball Bushing Bearings

Adjustable Precision Steel Ball Bushing Bearings (Closed Type) for End Supported Applications

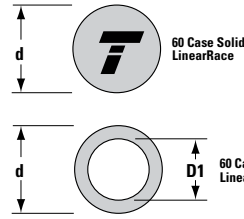
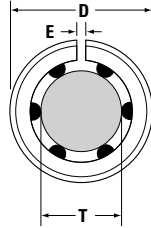
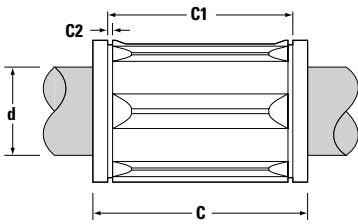
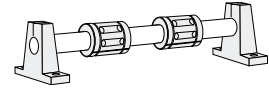

Sizes .250 thru 1.00 available in Corrosion Resistant Stainless Steel

Adjustable Precision Steel Ball Bushing Bearings and 60 Case LinearRace (Dimensions in inches)

Part Number ⁽²⁾		Nominal Diameter	Length C	Distance Between Retaining Grooves C1	Retaining Ring Groove min. C2	Min. Slot Width E	Number of Ball Circuits	60 Case LinearRace Minimum Depth of Hardness	60 Case Solid LinearRace Mass lb/in	60 Case Tubular Lite LinearRace Mass lb/in	60 Case Tubular Lite LinearRace ID D1
Precision Steel Ball Bushing Bearing	60 Case Linear Race										
ADJ81420	1/2 L	.500	1.250/1.235	.967/.951	.046	.06	4	.04	.06	–	–
ADJ101824	5/8 L	.625	1.500/1.485	1.108/1.092	.056	.09	4	.04	.09	–	–
ADJ122026	3/4 L	.750	1.625/1.610	1.170/1.154	.056	.09	5	.06	.13	.08	.46/.41
ADJ162536	1 L	1.000	2.250/2.235	1.759/1.741	.068	.09	5	.08	.22	.16	.62/.56
ADJ203242	1 1/4 L	1.250	2.625/2.605	2.009/1.991	.068	.09	6	.08	.35	–	–
ADJ243848	1 1/2 L	1.500	3.000/2.980	2.415/2.397	.086	.13	6	.08	.50	.33	.93/.84
ADJ324864	2 L	2.000	4.000/3.980	3.195/3.177	.103	.13	6	.10	.89	.54	1.31/1.18
ADJ406080	2 1/2 L	2.500	5.000/4.975	3.978/3.958	.120	.13	6	.10	1.39	.75	1.84/1.66
ADJ487296	3 L	3.000	6.000/5.970	4.728/4.708	.120	.13	6	.10	2.00	1.11	2.20/1.80
ADJ6496128	4 L	4.000	8.000/7.960	6.265/6.235	.139	.13	6	.10	3.56	1.56	3.30/2.70

Part Number ⁽²⁾	Working Bore Diameter T	Recommended Housing Bore Diameter D	60 Case LinearRace Diameter d	Precision Steel Ball Bushing Bearing Mass lb	Dynamic ⁽¹⁾ Load Capacity lb _f
		Normal Fit			
ADJ81420	.5000/.4995	.8755/.8750	.4995/.4990	.08	85
ADJ101824	.6250/.6245	1.1255/1.1250	.6245/.6240	.16	150
ADJ122026	.7500/.7495	1.2505/1.2500	.7495/.7490	.21	200
ADJ162536	1.0000/.9995	1.5630/1.5625	.9995/.9990	.38	350
ADJ203242	1.2500/1.2494	2.0010/2.0000	1.2495/1.2490	1.10	520
ADJ243848	1.5000/1.4994	2.3760/2.3750	1.4994/1.4989	1.43	770
ADJ324864	2.0000/1.9992	3.0010/3.0000	1.9994/1.9987	2.75	1100
ADJ406080	2.5000/2.4990	3.7510/3.7500	2.4993/2.4985	5.50	1800
ADJ487296	3.0000/2.9988	4.5010/4.5000	2.9992/2.9983	9.50	2600
ADJ6496128	4.0000/3.9980	6.0010/6.0000	3.9988/3.9976	20.20	5000

(1) The Dynamic Load Capacity is based on a rated travel life of 2 million inches. The actual Dynamic Load Capacity can be affected by the orientation of the bearing or the direction of the applied load. For dynamic load correction factors see polar graphs below.

(2) For part number description and specifications see page 71.

Note: Precision Steel Ball Bushing Bearings are available in corrosion resistant stainless steel in diameters up to 1 inch. Dynamic load ratings are reduced by 30% when using stainless steel Ball Bushing Bearings. For additional technical information, see the Engineering section beginning on page 262.

Inch – Precision Steel Ball Bushing Bearings

Load/Life Graph

(Lines indicate limiting load for given Ball Bushing Bearing)

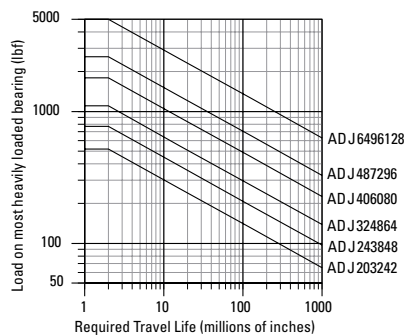
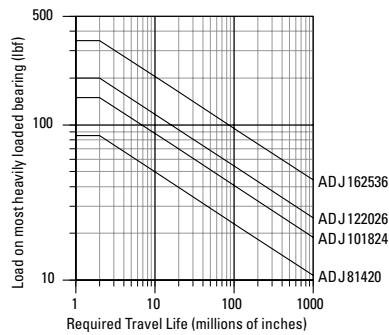

Determining Ball Bushing Bearing Size

To determine the proper Ball Bushing Bearing size enter the chart with the maximum load of the most heavily loaded bearing and the required travel life. Mark where the two lines intersect. All Ball Bushing Bearing sizes that pass through or above and to the right of this point may be suitable for this application.

Note: For the purpose of using this chart.

Load on most heavily loaded bearing = maximum applied load/ K_0 .

Where K_0 can be determined from the Polar Graph to the right.

Polar Graphs

The actual Dynamic Load Capacity of a Ball Bushing Bearing is determined by the orientation of the bearing or direction of the applied load. The load Correction Factor K_0 is found by knowing the direction of the applied load relative to the orientation of the bearings ball tracks and referring to the polar graph. To determine the actual Dynamic Load Capacity, multiply the proper correction factor by the Dynamic Load Capacity listed in the product table on the previous page.

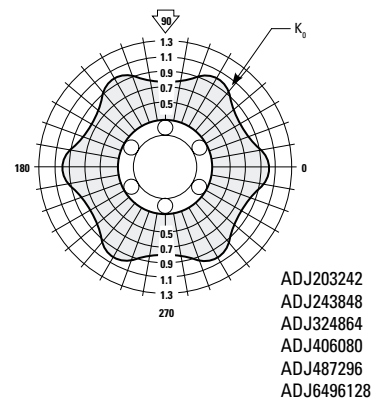
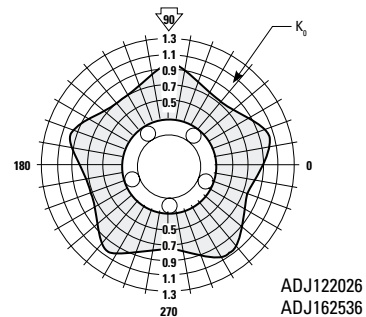
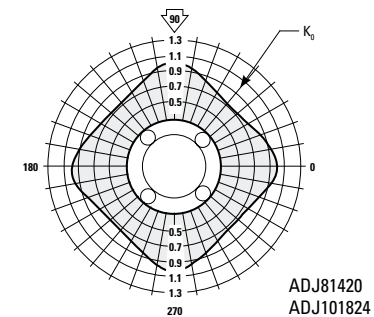

Inch – Precision Steel Ball Bushing Bearings

Precision Steel Ball Bushing Pillow Blocks (Closed and Adjustable Type) for End Supported Applications

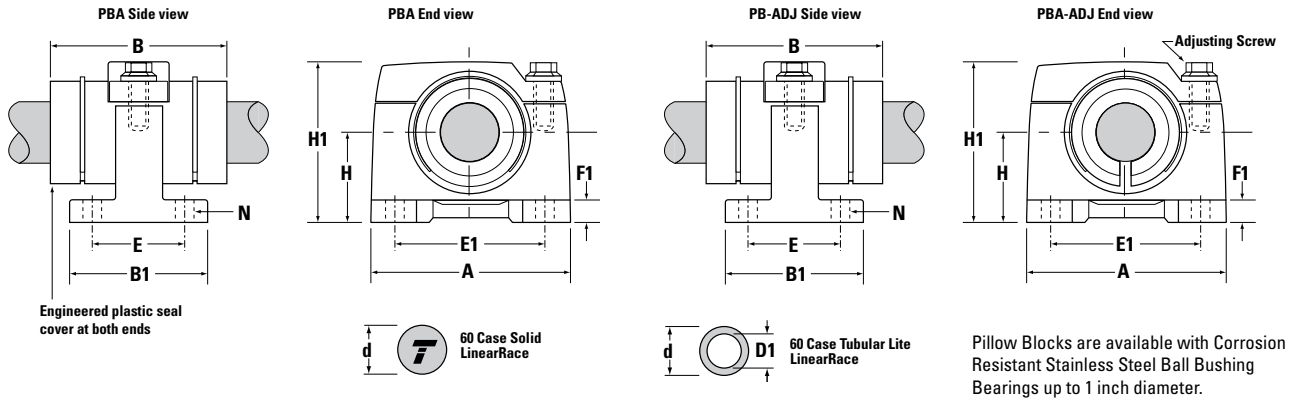
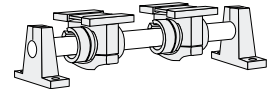

Precision Steel Ball Bushing Pillow Blocks (Closed and Adjustable Type) and 60 Case LinearRace (Dimensions in inches)

Part Number ⁽²⁾				Nom. Dia.	H ±.005	H1	Class S 60 Case LinearRace Diameter d	Class L 60 Case LinearRace Diameter d	60 Case LinearRace Minimum Depth of Hardness	60 Case Solid LinearRace Mass lb/in	60 Case Tubular Lite LinearRace Mass lb/in	60 Case Tubular Lite LinearRace ID D1
Precision Steel Ball Bushing Pillow Block	60 Case LinearRace Class S	Precision Steel Ball Bushing Pillow Block	60 Case LinearRace Class L									
Closed		Adjustable										
PB8A	1/2 S	PB8ADJ	1/2 L	.500	.875	1.63	.4990/.4985	.4995/.4990	.04	.06	–	–
PB12A	3/4 S	PB12ADJ	3/4 L	.750	1.125	2.13	.7490/.7485	.7495/.7490	.06	.13	.08	.46/.41
PB16A	1 S	PB16ADJ	1 L	1.000	1.375	2.56	.9990/.9985	.9995/.9990	.08	.22	.16	.62/.56
PB20A	1 1/4 S	PB20ADJ	1 1/4 L	1.250	1.750	3.25	1.2490/1.2485	1.2495/1.2490	.08	.35	–	–
PB24A	1 1/2 S	PB24ADJ	1 1/2 L	1.500	2.000	3.75	1.4989/1.4984	1.4994/1.4989	.08	.50	.33	.93/.84
PB32A	2 S	PB32ADJ	2 L	2.000	2.500	4.75	1.9987/1.9980	1.9994/1.9987	.10	.89	.54	1.31/1.18

Part Number ⁽²⁾		A	B	B1	E ±.010	E1 ±.010	F1	N		Pillow Block Mass lb	Dynamic ⁽¹⁾ Load Capacity lb _f
Precision Steel Ball Bushing Pillow Block								Hole	Bolt		
Closed	Adjustable										
PB8A	PB8ADJ	2.00	1.69	1.50	1.000	1.500	.25	.19	#8	.5	85
PB12A	PB12ADJ	2.75	2.06	2.00	1.375	2.000	.31	.22	#10	1.3	200
PB16A	PB16ADJ	3.25	2.88	2.25	1.500	2.500	.38	.28	1/4	2.1	350
PB20A	PB20ADJ	4.00	3.63	2.75	1.875	3.000	.44	.34	5/16	4.4	520
PB24A	PB24ADJ	4.75	4.00	3.00	2.000	3.500	.50	.34	5/16	5.7	770
PB32A	PB32ADJ	6.00	5.00	3.50	2.500	4.500	.63	.41	3/8	10.5	1100

(1) The Dynamic Load Capacity is based on a rated travel life of 2 million inches. The actual Dynamic Load Capacity can be affected by the orientation of the bearing or the direction of the applied load. For dynamic load correction factors see polar graphs below.

(2) For part number description and specifications see page 71.

Note: Precision Steel Ball Bushing Bearings are available in corrosion resistant stainless steel in diameters up to 1 inch. Dynamic load ratings are reduced by 30% when using stainless steel Ball Bushing Bearings. For additional technical information, see the Engineering section beginning on page 262.

Inch – Precision Steel Ball Bushing Bearings

Load/Life Graph

(Lines indicate limiting load for given Ball Bushing Bearing)

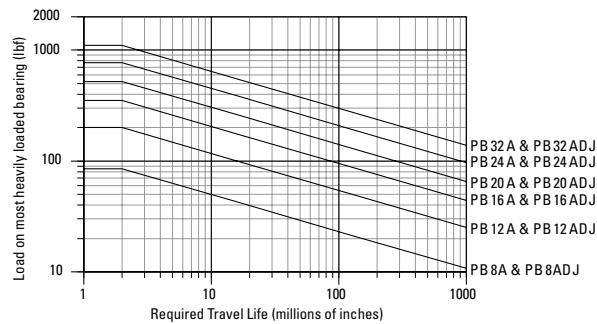

Determining Ball Bushing Bearing Size

To determine the proper Ball Bushing Bearing size enter the chart with the maximum load of the most heavily loaded bearing and the required travel life. Mark where the two lines intersect. All Ball Bushing Bearing sizes that pass through or above and to the right of this point may be suitable for this application.

Note: For the purpose of using this chart.

Load on most heavily loaded bearing = maximum applied load/ K_0 .

Where K_0 can be determined from the Polar Graph to the right.

Polar Graphs

The actual Dynamic Load Capacity of a Ball Bushing Bearing is determined by the orientation of the bearing or direction of the applied load. The load Correction Factor K_0 is found by knowing the direction of the applied load relative to the orientation of the bearings ball tracks and referring to the polar graph. To determine the actual Dynamic Load Capacity, multiply the proper correction factor by the Dynamic Load Capacity listed in the product table on the previous page.

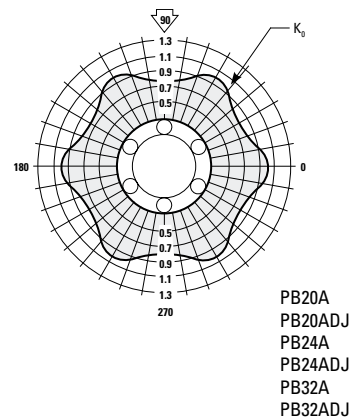
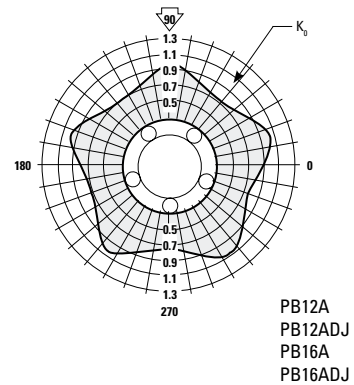
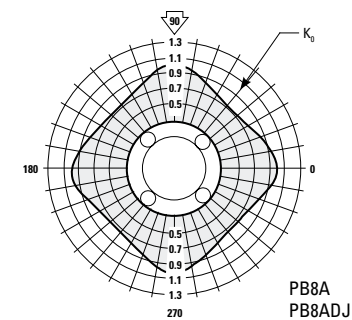

Inch – Precision Steel Ball Bushing Bearings

Miniature Instrument Ball Bushing Bearing and 60 Case LinearRace Sets

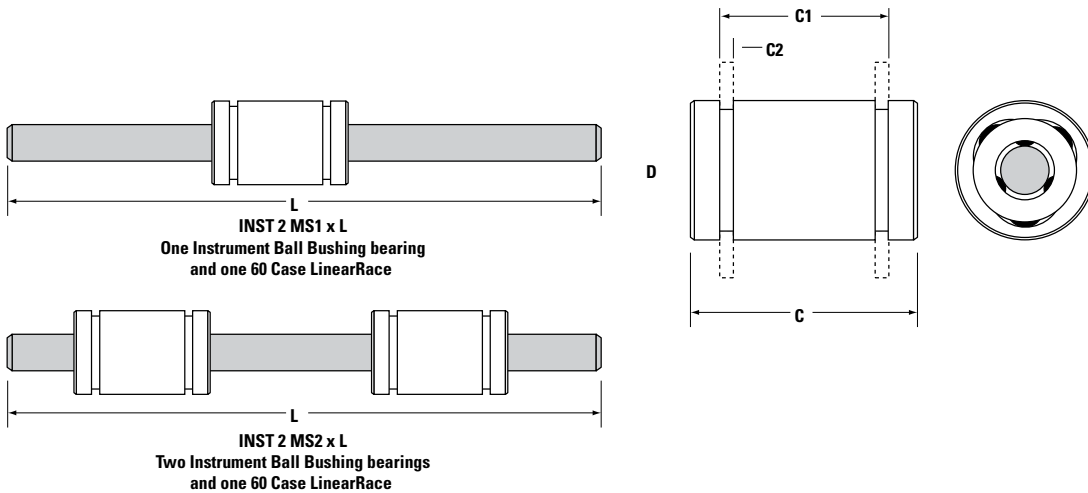
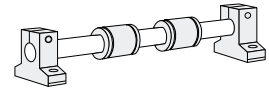

Miniature Instrument Ball Bushing Bearings and 60 Case LinearRace Sets (Dimensions in inches)

Part Number		Nominal Diameter	Outside Diameter D	Ball Bushing Bearing Length C	Distance Between Retaining Rings C1	Retaining Ring Groove min. C2	Recommended ‡ Housing Bore	Number of Ball Circuits	Ball Bushing Bearing Mass lb/in	60 Case LinearRace Mass lb/in
One Bearing	Two Bearings									
INST 2 MS1	INST 2 MS2	.1250	.3125/.3121	.500/.485	.354	.028	.3130/.3124	3	.007	.004
INST 3 MS1	INST 3 MS2	.1875	.3750/.3746	.562/.547	.417	.028	.3755/.3749	3	.011	.008
INST 4 MS1	INST 4 MS2	.2500	.5000/.4996	.750/.735	.499	.039	.5005/.4999	3	.025	.014

Miniature Instrument Ball Bushing Bearings (Dimensions in inches)

Part Number	Working Bore Diameter	60 Case LinearRace Part Number	LinearRace Maximum Length	60 Case LinearRace Diameter d	Instrument Ball Bushing Bearing/LinearRace Set Fit Up	Dynamic ⁽¹⁾ Load Capacity lb _r
INST 258-SS	.1250/.1247	LRI 2	12	.1248/.1247	.0003C/.0001C	7
INST 369-SS	.1875/.1872	LRI 3	12	.1873/.1872	.0003C/.0001C	9
INST 4812-SS	.2500/.2497	LRI 4	12	.2498/.2497	.0003C/.0001C	19

‡ Press fit not recommended.

(1) The Dynamic Load Capacity is based on a rated travel life of 2 million inches.

The actual Dynamic Load Capacity can be affected by the orientation of the bearing or the direction of the applied load. For dynamic load correction factors see polar graphs below. The dynamic load capacity for MS2 configurations are based on two bearings equally loaded.

Note: For additional technical information, see the Engineering section beginning on page 262.

Part Number Description

INST 2 MS1 x L3.0

Instrument	60 Case LinearRace diameter	Type of Matched Set	Length of 60 Case LinearRace in inches (3.0 in.)
Ball	2 1/8 in.	MS1 one bearing and one 60 Case LinearRace	
Bushing	3 3/16 in.	MS2 two bearings and one 60 Case LinearRace	
Product	4 1/4 in.		

60 Case LinearRace Specifications
Material: 440 Stainless Steel
Hardness: 55 HRC minimum
Surface Finish: 4 R_a microinch
Straightness: .0001 inch per inch

Inch – Precision Steel Ball Bushing Bearings

Load/Life Graph

(Lines indicate limiting load for given Ball Bushing Bearing)

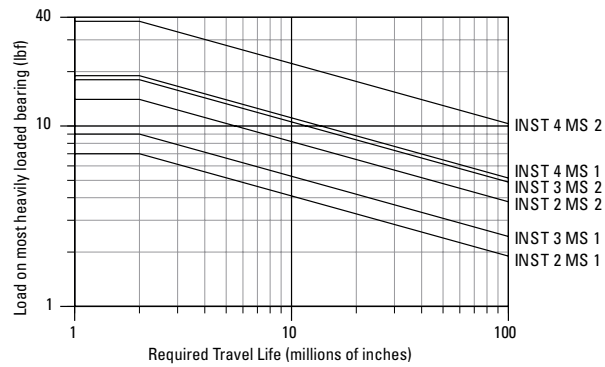

Determining Ball Bushing Bearing Size

To determine the proper Ball Bushing Bearing size enter the chart with the maximum load of the most heavily loaded bearing and the required travel life. Mark where the two lines intersect. All Ball Bushing Bearing sizes that pass through or above and to the right of this point may be suitable for this application.

Note: For the purpose of using this chart.

Load on most heavily loaded bearing = maximum applied load/ K_0 .

Where K_0 can be determined from the Polar Graph to the right.

Polar Graphs

The actual Dynamic Load Capacity of a Ball Bushing Bearing is determined by the orientation of the bearing or direction of the applied load. The load Correction Factor K_0 is found by knowing the direction of the applied load relative to the orientation of the bearings ball tracks and referring to the polar graph. To determine the actual Dynamic Load Capacity, multiply the proper correction factor by the Dynamic Load Capacity listed in the product table on the previous page.

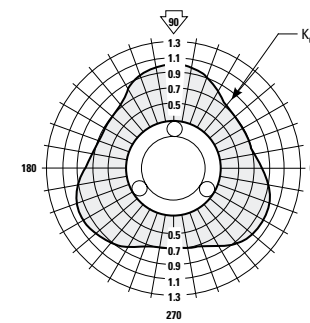

INST258SS
INST369SS
INST4812SS

Inch – Precision Steel Ball Bushing Bearings

Die Set Ball Bushing Bearings for End Supported Applications

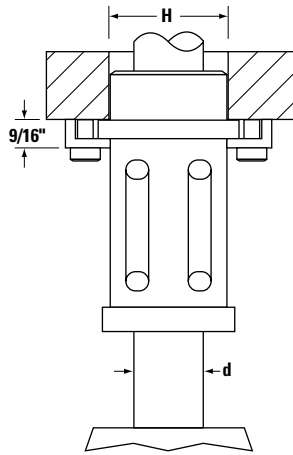
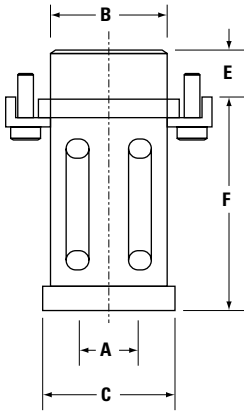
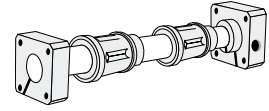

Precision Series Die Set Ball Bushing Bearings and 60 Case LinearRace (Dimensions in inches)

Part Number		Nominal Diameter	60 Case LinearRace Diameter d	Working Bore Diameter A	Ball Bushing Pilot Diameter B	O.D. C	Ball Bushing Bearing Pilot Length E	F	Bearing Weight lb	Recommended Mounting Hole Diameter H	Concentricity of Pilot (B) to Bearing Bore (A) (TIR)	Dynamic Load Capacity lb _r ⁽¹⁾
DS Ball Bushing Bearing	60 Case LinearRace											
DS16	1 D	1.000	1.0003/1.0000	.9999/.9996	1.5007/1.5003	1.91	.94	3.17	1.350	1.5005/1.5000	.0007	350
DS20	1 1/4 D	1.250	1.2503/1.2500	1.2498/1.2495	1.7507/1.7503	2.31	1.19	3.67	2.145	1.7505/1.7500	.0007	520
DS24	1 1/2 D	1.500	1.5003/1.5000	1.4997/1.4994	2.0007/2.0003	2.72	1.44	4.17	3.255	2.0005/2.0000	.0007	770
DS32	2 D	2.000	2.0003/2.0000	1.9995/1.9992	2.5007/2.5003	3.53	1.94	4.42	5.640	2.5005/2.5000	.0007	1100

(1) The Dynamic Load Capacity is based on a rated travel life of 2 million inches. The actual Dynamic Load Capacity can be affected by the orientation of the bearing or the direction of the applied load. For dynamic load correction factors see polar graphs below.
Note: For additional technical information, see the Engineering section beginning on page 262.

Inch – Precision Steel Ball Bushing Bearings

Load/Life Graph

(Lines indicate limiting load for given Ball Bushing Bearing)

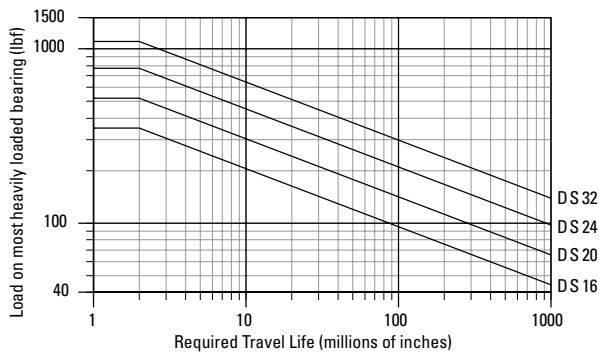

Determining Ball Bushing Bearing Size

To determine the proper Ball Bushing Bearing size enter the chart with the maximum load of the most heavily loaded bearing and the required travel life. Mark where the two lines intersect. All Ball Bushing Bearing sizes that pass through or above and to the right of this point may be suitable for this application.

Note: For the purpose of using this chart.

Load on most heavily loaded bearing = maximum applied load/ K_0 .

Where K_0 can be determined from the Polar Graph to the right.

Polar Graphs

The actual Dynamic Load Capacity of a Ball Bushing Bearing is determined by the orientation of the bearing or direction of the applied load. The load Correction Factor K_0 is found by knowing the direction of the applied load relative to the orientation of the bearings ball tracks and referring to the polar graph. To determine the actual Dynamic Load Capacity, multiply the proper correction factor by the Dynamic Load Capacity listed in the product table on the previous page.

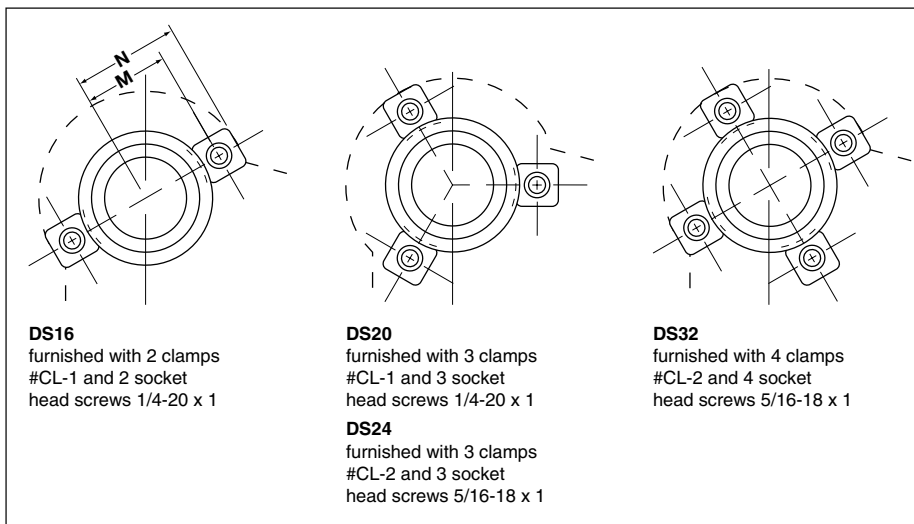
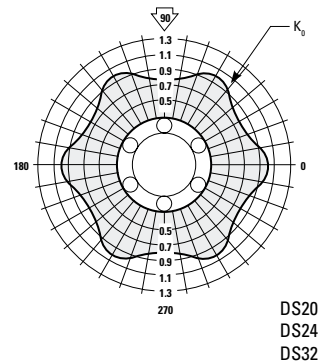
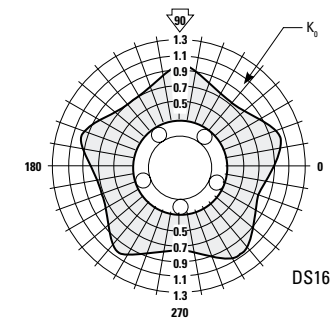

Die Set DS (Dimensions in Inches)

Part Number		M	N
DS Ball Bushing Bearing	DS-B Ball Bushing Bearing		
DS16	DS-16B	1.06	1.41
DS20	DS-20B	1.27	1.61
DS24	DS-24B	1.56	2.00
DS32	DS-32B	1.94	2.38

Inch – Precision Steel Ball Bushing Bearings

Part Number Description and Specification

Precision Steel Ball Bushing Bearings (Open Type) for Continuously Supported Applications

OPN162536DD-SS

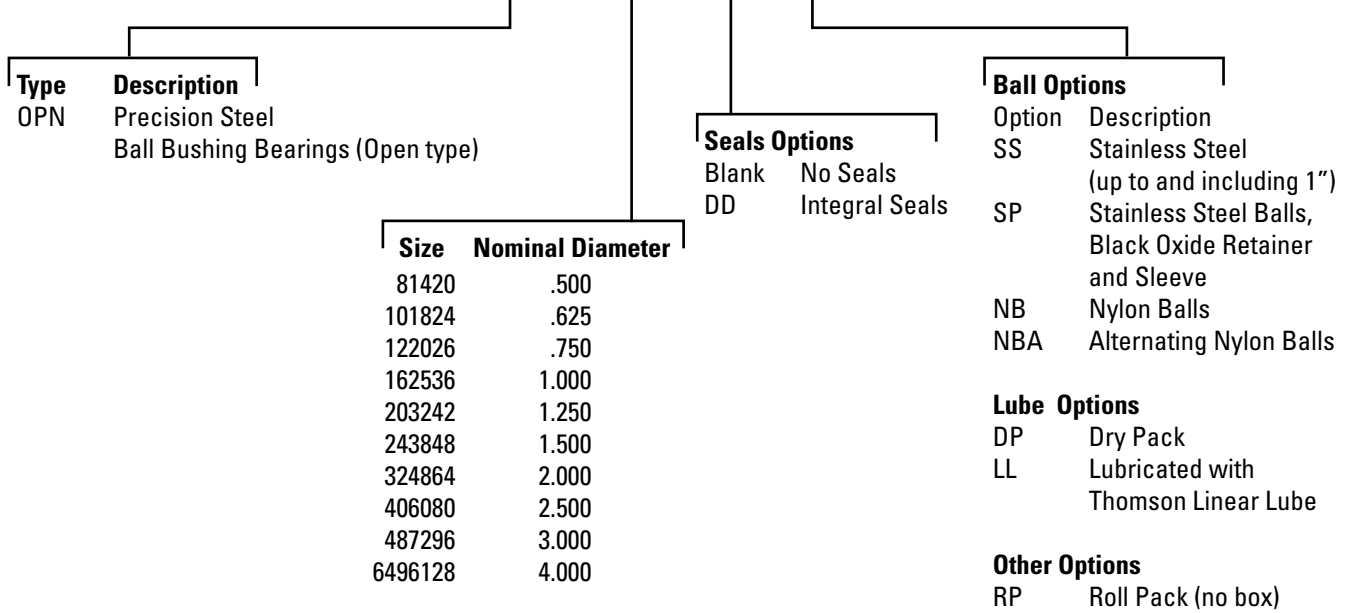

Precision Steel Ball Bushing Pillow Blocks (Open Type) for Continuously Supported Applications

PBO80PN-SS

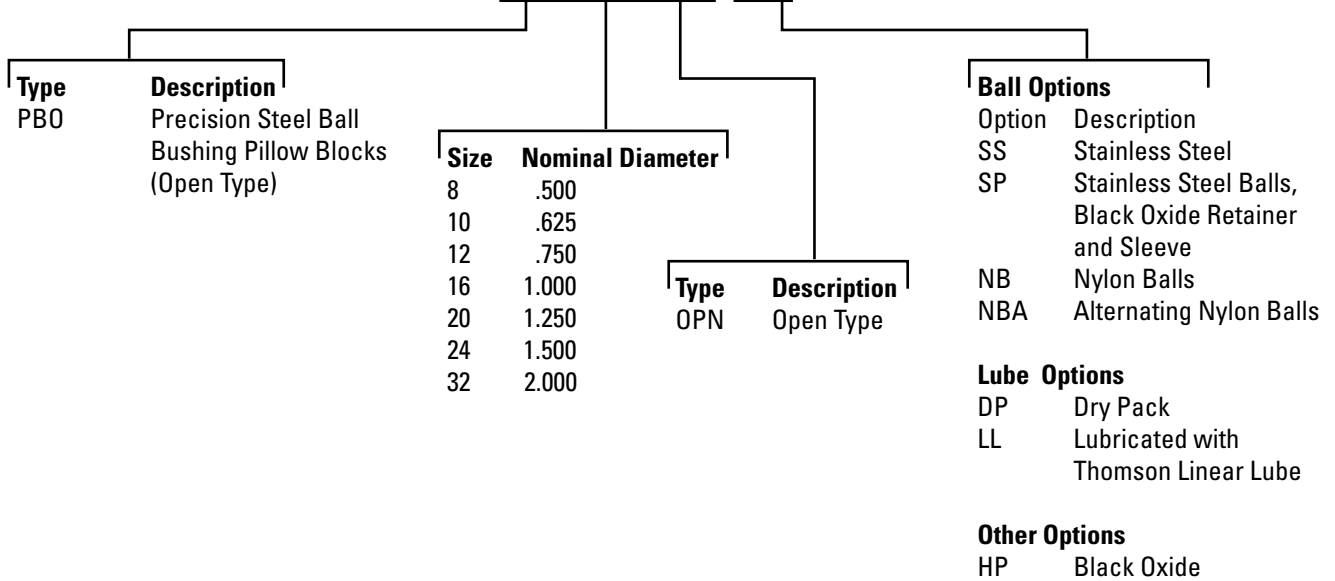

For addition informaiton on bearing options see page 273.

Inch – Precision Steel Ball Bushing Bearings

Precision Steel Ball Bushing Bearings (Open Type) for Continuously Supported Applications

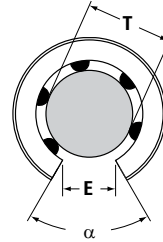
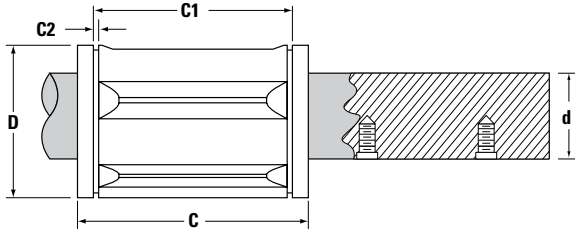
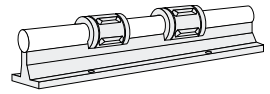

Sizes .500 thru 1.00 available in Corrosion resistant Stainless Steel.

Precision Steel Ball Bushing Bearings (Open Type) and 60 Case LinearRace (Dimensions in inches)

Part Number ⁽³⁾		Nominal Diameter	Length C	Distance Between Retaining Rings C1	Ret. Ring Groove min. C2
Precision Steel Ball Bushing Bearing	60 Case LinearRace*				
OPN81420	1/2 L PD	.500	1.250/1.235	.967/.951	.046
OPN101824	5/8 L PD	.625	1.500/1.485	1.108/1.092	.056
OPN122026	3/4 L PD	.750	1.625/1.610	1.170/1.154	.056
OPN162536	1 L PD	1.000	2.250/2.235	1.759/1.741	.068
OPN203242	1 1/4 L PD	1.250	2.625/2.605	2.009/1.991	.068
OPN243848	1 1/2 L PD	1.500	3.000/2.980	2.415/2.397	.086
OPN324864	2 L PD	2.000	4.000/3.980	3.195/3.177	.103
OPN406080	2 1/2 L	2.500	5.000/4.975	3.978/3.958	.120
OPN487296	3 L	3.000	6.000/5.970	4.728/4.708	.120
OPN6496128	4 L	4.000	8.000/7.960	6.265/6.235	.139

* 60 Case begins on page 170.

Part Number ⁽³⁾	Working Bore Diameter T	Recommended Housing Bore Before Adjustment D	60 Case LinearRace Diameter d	Minimum Slot Width E	Angle deg alpha	Number of Ball Circuits	Ball Bushing Bearing Mass lb	Dynamic ⁽¹⁾ Load Capacity lb _f
OPN81420	.5005/.4995	.8760/.8740	.4995/.4990	.31	50	3	.07	60
OPN101824	.6255/.6245	1.1260/1.1240	.6245/.6240	.38	60	3	.11	105
OPN122026	.7505/.7495	1.2510/1.2490	.7495/.7490	.44	60	4	.17	140
OPN162536	1.0005/.9995	1.5635/1.5615	.9995/.9990	.56	60	4	.32	240
OPN203242	1.2506/1.2494	2.0010/1.9990	1.2495/1.2490	.63	50	5	.90	400
OPN243864	1.5006/1.4994	2.3760/2.3740	1.4994/1.4989	.75	50	5	1.12	600
OPN324864	2.0008/1.9992	3.0010/2.9990	1.9994/1.9987	1.00	50	5	2.16	860
OPN406080	2.5010/2.4990	3.7515/3.7485	2.4993/2.4985	1.25	50	5	4.24	1380
OPN487296	3.0012/2.9988	4.5015/4.4985	2.9992/2.9983	1.50	50	5	7.33	2000
OPN6496128	4.0020/3.9980	6.0020/5.9980	3.9988/3.9976	2.00	50	5	17.25	3800

(1) The Dynamic Load Capacity is based on a rated travel life of 2 million inches. The actual Dynamic Load Capacity can be affected by the orientation of the bearing or the direction of the applied load. For dynamic load correction factors see polar graphs below. See page 151 for Stainless Steel bearing derating.

(3) For part number description and specifications see page 84.

Inch – Precision Steel Ball Bushing Bearings

Load/Life Graph

(Lines indicate limiting load for given Ball Bushing Bearing)

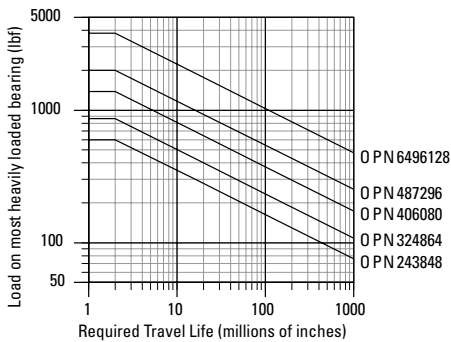
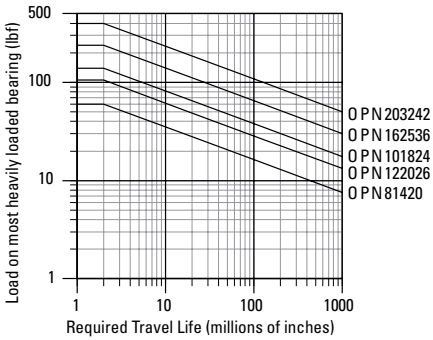

Determining Ball Bushing Bearing Size

To determine the proper Ball Bushing Bearing size enter the chart with the maximum load of the most heavily loaded bearing and the required travel life. Mark where the two lines intersect. All Ball Bushing Bearing sizes that pass through or above and to the right of this point may be suitable for this application.

Note: For the purpose of using this chart.

Load on most heavily loaded bearing = maximum applied load/ K_0 .

Where K_0 can be determined from the Polar Graph to the right.

Polar Graphs

The actual Dynamic Load Capacity of a Ball Bushing Bearing is determined by the orientation of the bearing or direction of the applied load. The load Correction Factor K_0 is found by knowing the direction of the applied load relative to the orientation of the bearings ball tracks and referring to the polar graph. To determine the actual Dynamic Load Capacity, multiply the proper correction factor by the Dynamic Load Capacity listed in the product table on the previous page.

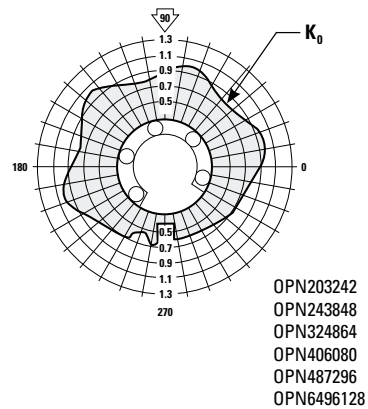
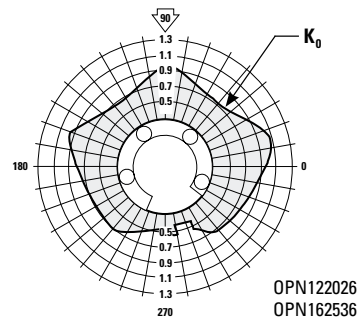
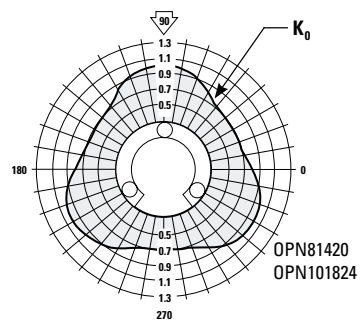

Inch – Precision Steel Ball Bushing Bearings

Precision Steel Ball Bushing Bearing Pillow Block

(Open Type) for Continuously Supported Applications

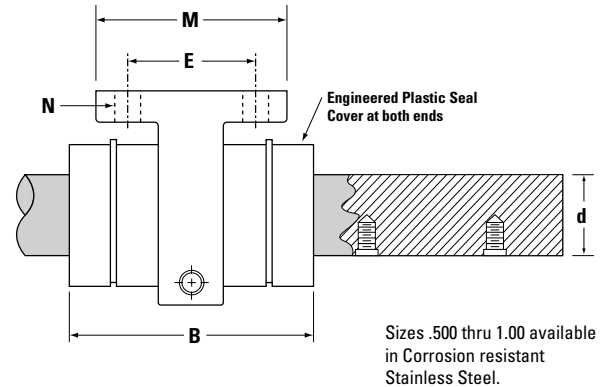
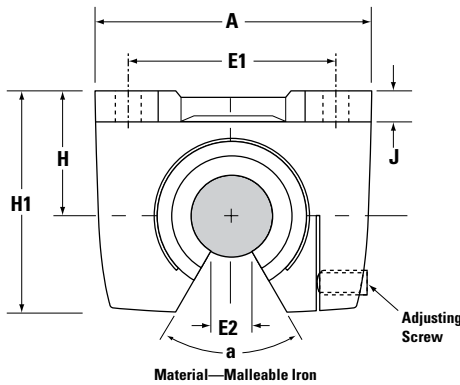
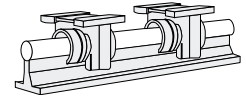

Precision Steel Ball Bushing Bearing Pillow Blocks (Open Type, seal at both ends) and 60 Case LinearRace (Dim. in inches)

Part Number ⁽³⁾		Nominal Diameter	H ±.005	H1
Precision Steel Ball Bushing Pillow Block	60 Case LinearRace*			
PB080PN	1/2 L PD	.500	.875	1.50
PB0120PN	3/4 L PD	.750	1.125	2.00
PB0160PN	1 L PD	1.000	1.375	2.38
PB0200PN	1 1/4 L PD	1.250	1.750	3.06
PB0240PN	1 1/2 L PD	1.500	2.000	3.50
PB0320PN	2 L PD	2.000	2.500	4.50

* 60 Case begins on page 170.

Part Number ⁽³⁾	60 Case LinearRace Diameter d	A	B	E ±.010	E1 ±.010	E2 min.	J	α deg	M	N		Pillow Block Weight lb	Dynamic ⁽¹⁾ Load Capacity lb _f
										Hole	Bolt		
PB080PN	.4995/.4990	2.00	1.69	1.000	1.500	.37	.25	50	1.50	.19	#8	.4	60
PB0120PN	.7495/.7490	2.75	2.06	1.375	2.000	.43	.31	60	2.00	.22	#10	1.0	140
PB0160PN	.9995/.9990	3.25	2.88	1.500	2.500	.56	.38	60	2.25	.28	1/4	1.8	240
PB0200PN	1.2495/1.2490	4.00	3.63	1.875	3.000	.67	.44	50	2.75	.34	5/16	3.8	400
PB0240PN	1.4994/1.4989	4.75	4.00	2.000	3.5000	.81	.50	50	3.00	.34	5/16	4.8	600
PB0320PN	1.9994/1.9987	6.00	5.00	2.500	4.500	1.00	.63	50	3.50	.41	3/8	8.5	860

(1) The Dynamic Load Capacity is based on a rated travel life of 2 million inches. The actual Dynamic Load Capacity can be affected by the orientation of the bearing or the direction of the applied load. For dynamic load correction factors see polar graphs below.

(3) For part number description and specifications see page 84.

Note: Precision Steel Ball Bushing Bearings are available in corrosion resistant stainless steel in diameters up to 1 inch. Dynamic load ratings are reduced by 30% when using stainless steel Ball Bushing Bearings. For additional technical information, see the Engineering section beginning on page 262.

Inch – Precison Steel Ball Bushing Bearings

Load/Life Graph

(Lines indicate limiting load for given Ball Bushing Bearing)

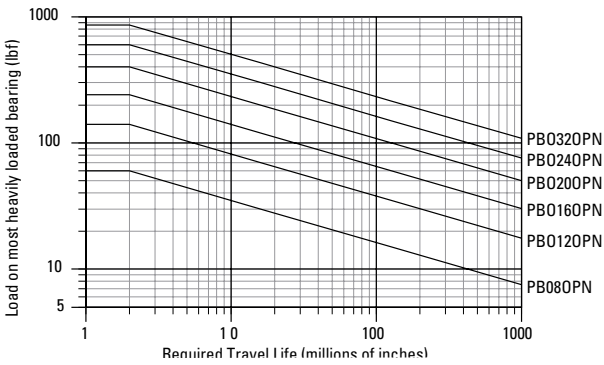

Determining Ball Bushing Bearing Size

To determine the proper Ball Bushing Bearing size enter the chart with the maximum load of the most heavily loaded bearing and the required travel life. Mark where the two lines intersect. All Ball Bushing Bearing sizes that pass through or above and to the right of this point may be suitable for this application.

Note: For the purpose of using this chart.

Load on most heavily loaded bearing = maximum applied load/ K_0 .

Where K_0 can be determined from the Polar Graph to the right.

Polar Graphs

The actual Dynamic Load Capacity of a Ball Bushing Bearing is determined by the orientation of the bearing or direction of the applied load. The load Correction Factor K_0 is found by knowing the direction of the applied load relative to the orientation of the bearings ball tracks and referring to the polar graph. To determine the actual Dynamic Load Capacity, multiply the proper correction factor by the Dynamic Load Capacity listed in the product table on the previous page.

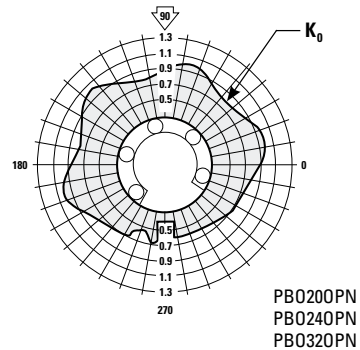
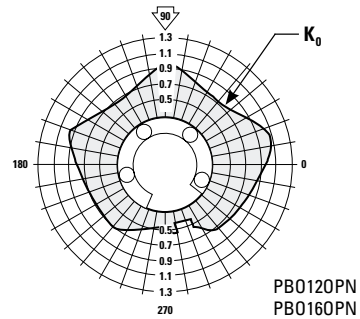
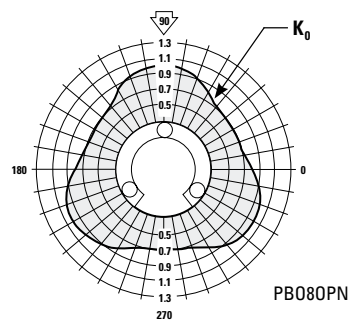

Inch – Precision Steel Ball Bushing Bearings

Wire Straightening/Feeding Mechanism

Objective

Redesign a wire straightening/feeding mechanism for a wire drawing machine that improves cycle time and minimizes downtime.

Solution

Combine the performance advantages of the Precision Steel Ball Bushing Bearing with the operating efficiency of Thomson ball screws.

Products Specified

- 4 - A162536 (Precision Steel Ball Bushing Bearings)
- 2 - 1 S CTL (60 Case LinearRace)
- 1 - .625 x .200 (Thomson ball screw assembly)

Benefits

By replacing high friction plain bearings with Precision Steel Ball Bushing Bearings, service life increased from six months to four years. This significantly reduced downtime and maintenance requirements and provided increased productivity with substantial.

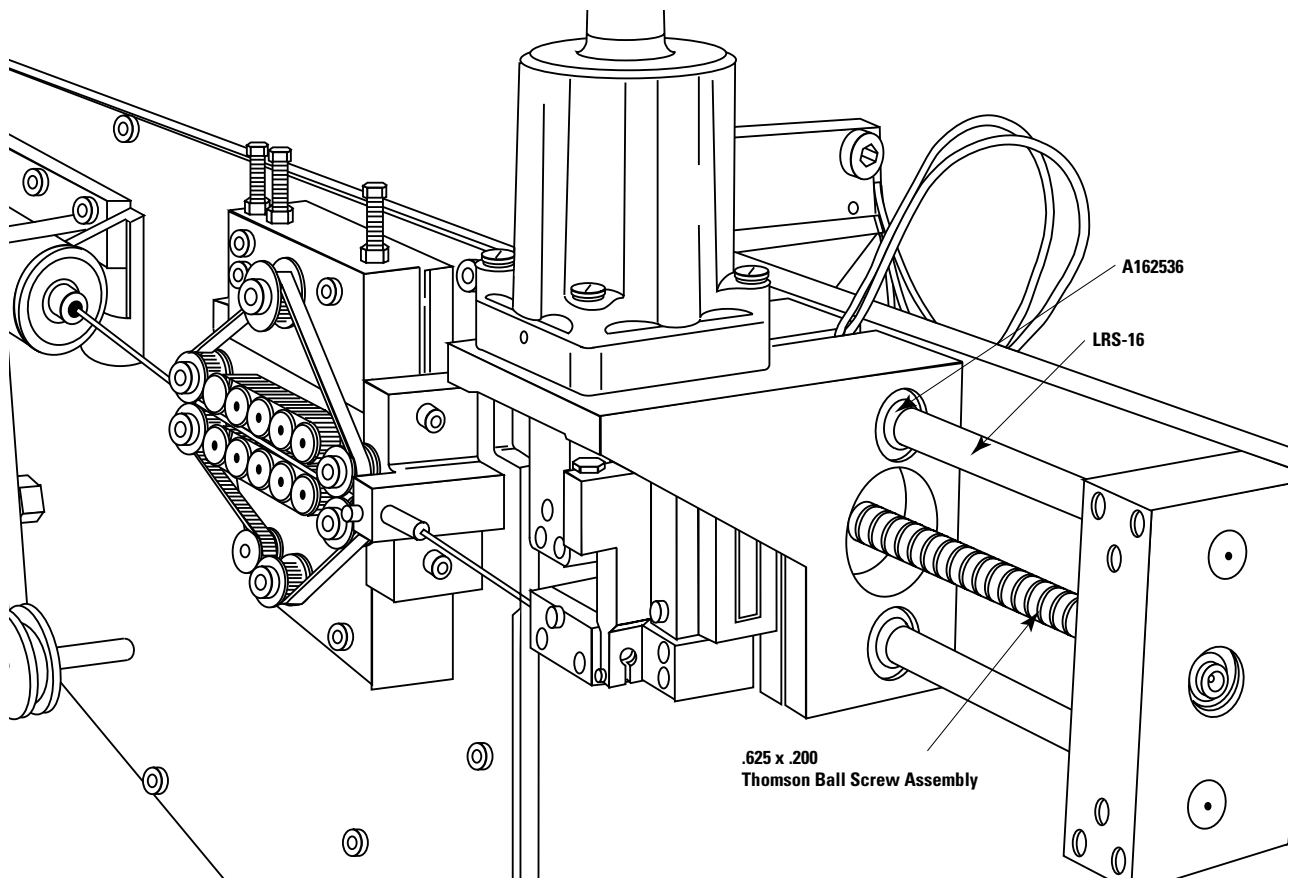

Inch – XR Ball Bushing Bearings

XR Ball Bushing Bearing Products

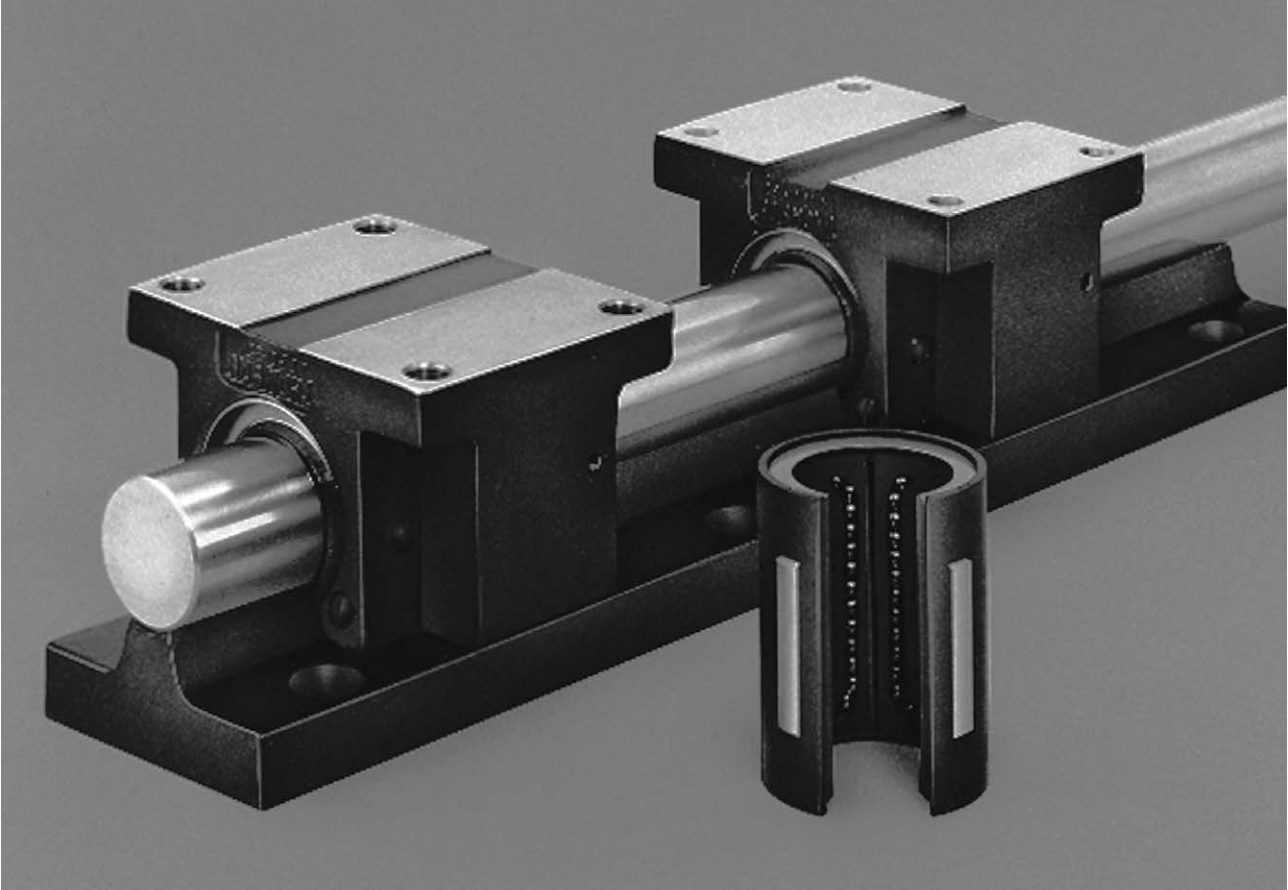

Thomson XR Ball Bushing Bearing products offer:

- Five times the load capacity or 125 times the travel life of conventional linear bearings. This dramatic increase in travel life reduces downtime and maximizes productivity.
- Three times the rigidity of conventional linear bearings. This increase in stiffness provides immediate improvements in machine positioning accuracy and repeatability.
- The RoundRail Advantage combined with travel speeds up to 5 ft/s. Derating factors commonly found in linear guide products are eliminated.
- Ease of maintenance. When normal maintenance requires bearing replacement, XR Ball Bushing Bearings can be quickly and cost-effectively replaced without scrapping the entire system – another shortcoming of some linear guides.
- Double acting seals at both ends that keep out contamination and retain lubrication.
- Lasting precision alignment by combining the non-wear characteristics of the XR Ball Bushing Bearing with a rigid ductile iron pillow block.
- High accelerations and operating speeds without a dramatic increase in the power consumption commonly seen with high friction v-way and flat-way systems.

Inch – XR Ball Bushing Bearings

XR Ball Bushing Bearing products provide five times the load capacity or 125 times the travel life and three times the rigidity of conventional linear bearings. These improvements are centered around four technologically advanced components, the XR Ball Bushing Bearing, the XPBO Ball Bushing pillow block, the XL 60 Case LinearRace (shaft) and the XSR 60 Case LinearRace support rail.

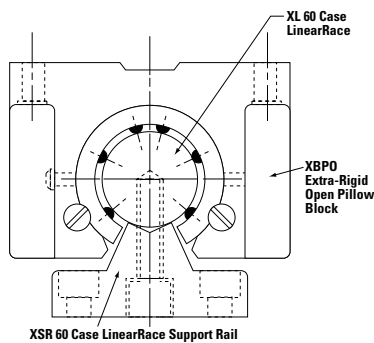

Figure 1

XR Ball Bushing Bearing

The dramatic increase in load capacity and/or travel life is provided by the XR Ball Bushing Bearing's advanced plate design. Each ball conforming bearing plate is precision ground providing smooth and virtually friction free linear movement. The bearing plate length has also been maximized to increase the number of rolling elements in the load carrying zone. The position of each XR bearing plate helps to maximize the load capacity in both pull-off and down loading conditions.

XPBO Ball Bushing Pillow Block

Each XR Ball Bushing Bearing can be housed in a rigid ductile iron pillow block (Figure 1). The XPBO pillow block provides the stiffness required in high load applications (Figure 2). Each XPBO is equipped with four mounting holes for easy assembly to the table surface.

XL 60 Case LinearRace

Available factory mounted to XSR 60 Case LinearRace support rail is a hardened and precision ground 60 Case LinearRace (Figure 1). Each 60 Case LinearRace is ground to a surface finish less than 10 Ra microinch and is straight to .001 inch per foot cumulative. Roundness of each 60 Case LinearRace is controlled through proprietary techniques that results in a roundness of 80 millionths of an inch. Each XL 60 Case LinearRace is held to these world class quality standard to assure maximum system performance and travel life.

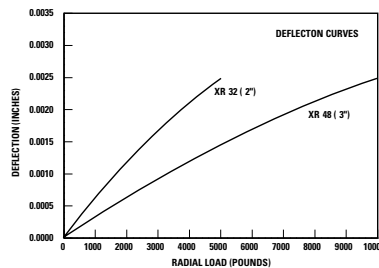

Figure 2

XSR 60 Case LinearRace Support Rails

Rigidity always starts by continuously supporting the 60 Case LinearRace and bearing system (Figure 1). The large ductile iron alloy cross-section of the XSR provides maximum rigidity and stiffness (Figure 2). The increased number of standard 60 Case LinearRace mounting holes add further stiffness and stability to the system.

The RoundRail Advantage

The RoundRail Advantage is the inherent ability of an XR Ball Bushing Bearing system to accommodate torsional misalignment (caused by inaccuracies in carriage or base machining or by machine deflection) with little increase in stress to bearing components. Installation time and cost are minimized and system performance is maximized.

Inch – XR Ball Bushing Bearings

XR Ball Bushing Bearings for Continuously Supported Applications

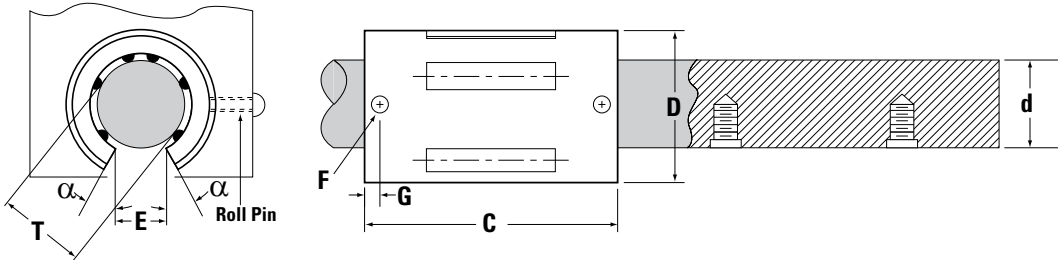
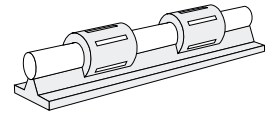

XR Ball Bushing Bearings and 60 Case LinearRace (Dimensions in inches)

Part Number		Nom. Dia.	Length C	60 Case LinearRace Diameter d
XR Ball Bushing Bearing	60 Case LinearRace*			
XR320PN	2 XL PD ⁽⁴⁾	2	4.000/3.970	1.9994/1.9991
XR480PN	3 XL PD ⁽⁴⁾	3	6.000/5.940	2.9992/2.9989

* 60 Case begins on page 170.

Part Number	Working Bore Diameter T	Recommended Housing Bore Diameter D	Minimum Slot Width E	Retention Hole ⁽²⁾		Angle deg α	Number of Ball Circuits	Ball Diameter	Bearing Mass lb	Dynamic Load Capacity lb _r
				Diameter F	Loc. G					
XR320PN	2.0000/1.9992	3.0000	1.00	.27	.31	27	6	.25	1.3	4500
XR480PN	3.0000/2.9988	4.5000	1.50	.27	.42	30	6	.38	4.4	10000

(1) When installed in a nominal housing bore D, before adjustment. Any deviation from nominal housing bore diameter will change the working bore T, an equal amount.

Minimum recommended housing bores are 2.9980 for XR-32-OPN and 4.4975 for XR-48-OPN.

(2) Retention hole does not go through bearing retainer.

(3) The Dynamic Load Capacity is based on a rated travel life of 2 million inches. The actual Dynamic Load Capacity can be affected by the orientation of the bearing or the direction of the applied load. For dynamic load correction factors see polar graphs opposite.

(4) Contact factory for availability.

Inch – XR Ball Bushing Bearings

Load/Life Graph

(Lines indicate limiting load for given Ball Bushing Bearing)

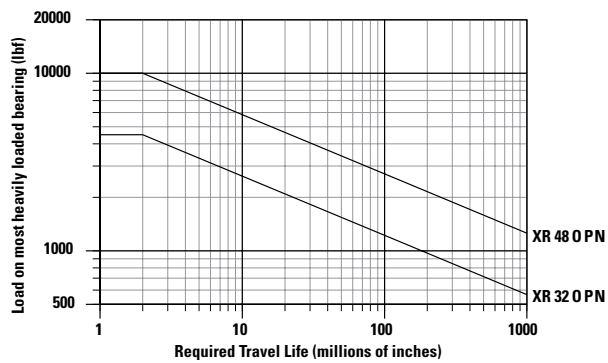

Determining Ball Bushing Bearing Size

To determine the proper Ball Bushing Bearing size enter the chart with the maximum load of the most heavily loaded bearing and the required travel life. Mark where the two lines intersect. All Ball Bushing Bearing sizes that pass through or above and to the right of this point may be suitable for this application.

Note: For the purpose of using this chart.

Load on most heavily loaded bearing = maximum applied load/ K_0 .

Where K_0 can be determined from the Polar Graph to the right.

Polar Graphs

The actual Dynamic Load Capacity of a Ball Bushing Bearing is determined by the orientation of the bearing or direction of the applied load. The load Correction Factor K_0 is found by knowing the direction of the applied load relative to the orientation of the bearings ball tracks and referring to the polar graph. To determine the actual Dynamic Load Capacity, multiply the proper correction factor by the Dynamic Load Capacity listed in the product table on the previous page.

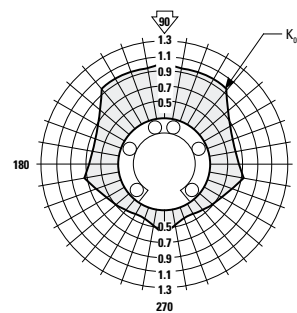

Inch – XR Ball Bushing Bearings

XR Ball Bushing Pillow Blocks for Continuously Supported Applications

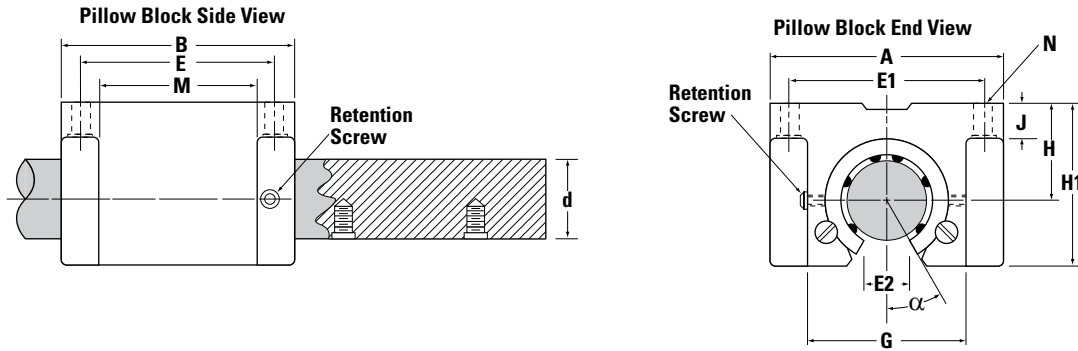
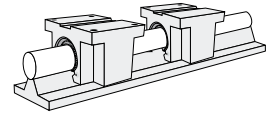

XR Ball Bushing Pillow Blocks (seal at both ends) and 60 Case LinearRace (Dimensions in inches)

Part Number		Nominal Diameter	H +0.000 -0.001	H1
Extra Rigid Ball Bushing Bearing	60 Case LinearRace*			
XPB0320PN	2 XL PD ⁽³⁾	2	2.375	3.875
XPB0480PN	3 XL PD ⁽³⁾	3	3.500	5.875

* 60 Case begins on page 170.

Part Number	Working Bore Diameter T	60 Case LinearRace Diameter d	Ball Bushing ⁽¹⁾ Bearing/LinearRace Fit Up	A	B	E ±.010	E1 ±.010	E2 min.	G	J	α deg	M	N	Pillow Block Mass lb	Dynamic ⁽²⁾ Load Capacity lb _i
XPB0320PN	1.9985/1.9972	1.9994/1.9991	.0022P/.006P	6.00	4.88	3.750	5.000	1.00	3.75	.88	27	2.63	.53 1/2	18	4500
XPB0480PN	2.9980/2.9963	2.9992/2.9989	.0029/.0009P	8.38	7.25	5.875	7.000	1.50	5.50	1.25	30	4.13	.66 5/8	55	10000

(1) XPBO pillow blocks are designed to give extra rigid support and are therefore dimensioned to provide the interference fits when used with 60 Case LinearRace class XL. If used with class L 60 Case LinearRace the fit-up values would be .0022P/.0002P for the 2 inch size and .0029P/.0003P for the 3 inch size.

(2) The Dynamic Load Capacity is based on a rated travel life of 2 million inches. The actual Dynamic Load Capacity can be affected by the orientation of the bearing or the direction of the applied load. For dynamic load correction factors see polar graphs opposite.

(3) Contact factory for availability.

Inch – XR Ball Bushing Bearings

Load/Life Graph

(Lines indicate limiting load for given Ball Bushing Bearing)

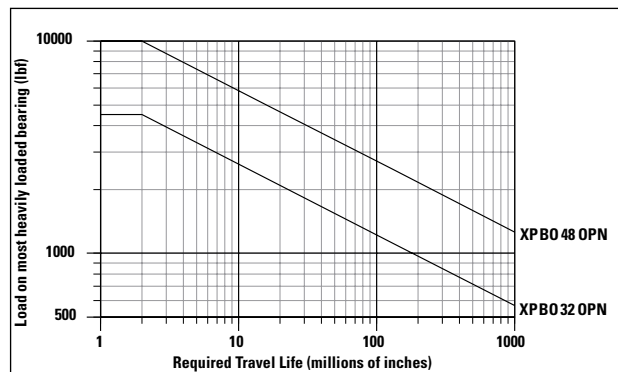

Determining Ball Bushing Bearing Size

To determine the proper Ball Bushing Bearing size enter the chart with the maximum load of the most heavily loaded bearing and the required travel life. Mark where the two lines intersect. All Ball Bushing Bearing sizes that pass through or above and to the right of this point may be suitable for this application.

Note: For the purpose of using this chart.

Load on most heavily loaded bearing = maximum applied load/ K_0 .

Where K_0 can be determined from the Polar Graph to the right.

Polar Graphs

The actual Dynamic Load Capacity of a Ball Bushing Bearing is determined by the orientation of the bearing or direction of the applied load. The load Correction Factor K_0 is found by knowing the direction of the applied load relative to the orientation of the bearings ball tracks and referring to the polar graph. To determine the actual Dynamic Load Capacity, multiply the proper correction factor by the Dynamic Load Capacity listed in the product table on the previous page.

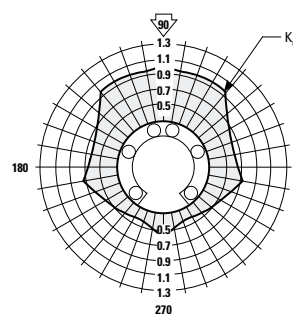

Inch – XR Ball Bushing Bearings

X-Y-Z System

Objective

Build a rigid X-Y-Z System designed to perform welding and flame cutting tasks.

Solution

Extra Rigid Ball Bushing Bearings will be used on the X-axis to minimize deflection of the cantilevered Y-axis. Self-aligning Super Smart Ball Bushing Bearings are used on the Y and Z axis to simplify the assembly.

Products Specified

X-axis

- 4 - XR-32-OPN (XR Ball Bushing Bearing)
- 2 - XSRA-32 x 108 in (60 Case LinearRace Support Rail Assembly)

Y-axis

- 4 - SSU-12-OPN (Super Smart Ball Bushing Bearing [Open Type])
- 2 - LSR-12-PD x 48 in (Low Profile 60 Case LinearRace Support Rail)
- 2 - 3/4 L PD CTL x 48 in (60 Case LinearRace)

Z-axis

- 4 - SSU-12 (Super Smart Ball Bushing Bearing)
- 2 - 3/4 L CTL x 36 in (60 Case LinearRace)

Benefits

The high load capacity, rigidity and RoundRail Advantage of the Super Smart and XR Ball Bushing Bearings provided an easy to assemble system with a repeatability of $\pm .005$ in.

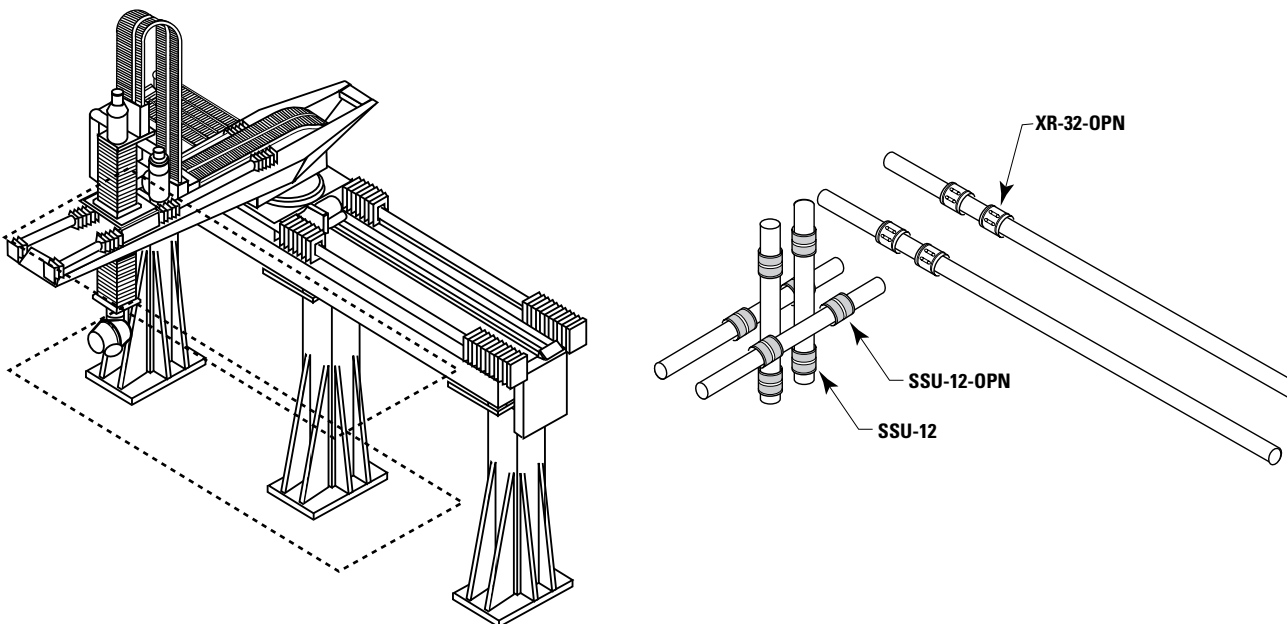

RoundWay Linear Roller Bearing Products



Thomson RoundWay Linear Roller Bearings offer:

- Up to twenty times the load capacity of conventional linear ball bearings. This dramatic increase allows for more compact machine designs with a reduction in hardware costs.
- A rigid design that provides high accuracy while tolerating the high shock loads common to machine tool applications.
- A coefficient of friction as low as .005. When replacing v-ways or flat-ways, RoundWay linear roller bearings allow for the use of smaller less expensive drives, motors, belts, gears and ball screws.
- A self-aligning capability that reduces installation time and cost.
- An eccentric trunnion pin that adjusts bearing height to compensate for minor inaccuracies in mounting base flatness or machining accuracy. Installation is quicker and easier than old style, conventional way systems.
- Availability of an integral wiper that protects against contamination while retaining lubrication.
- Interchangeable components for quick, cost-effective machine maintenance. There is no need to scrap the entire way system, a problem with some linear guide products.
- The RoundRail Advantage combined with the self aligning feature, eliminates the need for derating factors commonly seen with linear guides.
- Availability from over 1800 distributors worldwide.

Inch – RoundWay Linear Roller Bearings

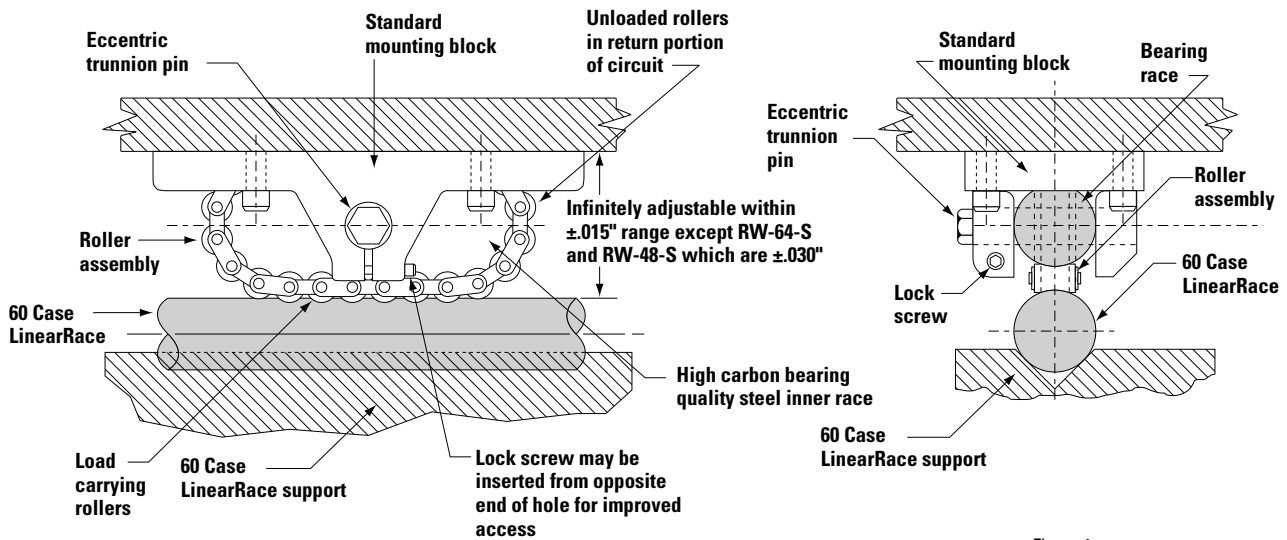

Figure 1

RoundWay Operating Principle

Thomson invented the RoundWay Linear roller bearing for use in high load, heavy duty applications. Each RoundWay bearing combines the high load capacity of hardened and ground steel recirculating rollers with a rigid malleable iron pillow block providing extremely high load capacity with smooth linear travel. The RoundWay linear roller bearing comes in both a single and dual version. A single RoundWay linear roller bearing does not resist side loads and is therefore always used in conjunction with a dual version, unless used in a configuration as shown in Figures 2, 3 and 4 on page 99.

Each RoundWay linear roller bearing is designed for use on 60 Case LinearRace. The 60 Case LinearRace shaft can be continuously supported using type LSR, SR, FLSR or XSR 60 Case LinearRace support rails or intermittently supported using the adjustable Waymount* LinearRace supports type WM.

The RoundWay linear roller bearing consists of four basic parts: the bearing race, the roller assembly, the eccentric trunnion pin and the mounting block. The rolling elements of a RoundWay linear roller bearing are a series of concave rollers interconnected and linked by a chain assembly. As load is applied to the mounting block it is transferred through the bearing race and roller assembly to the supported 60 Case LinearRace. Connecting the mounting block to the RoundWay bearing and roller assembly is an eccentric trunnion pin that allows the height of the RoundWay linear roller bearing to be adjusted to compensate for variations in the mounting surfaces or the build-up of tolerances between component elements. The eccentric trunnion pin can also be used to preload the RoundWay bearing by eliminating internal bearing clearance. After the eccentric trunnion pin has been adjusted it can be held in place by simply tightening the lock screw.

Self-Aligning

The RoundWay single and dual bearings are designed with a built-in self-aligning capability that absorbs misalignment caused by inaccuracies in carriage or base machining. The RoundWay single bearing has an additional built-in self-aligning capability that allows it to absorb misalignment caused by two slightly out of parallel 60 Case LinearRace ways. This feature is realized when two RoundWay single bearings are mounted on one 60 Case LinearRace and two dual RoundWay bearings are on a parallel 60 Case LinearRace (Figure 1 on page 99).

* Trademark of Thomson Industries Inc. Thomson Industries Inc. is registered in the U.S. Patent and Trademark Office and in other countries.

Inch – RoundWay Linear Roller Bearings

RoundWay Linear Roller Bearing Mounting Configurations

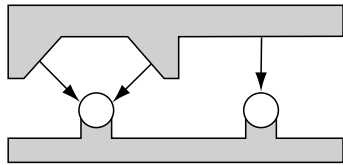

Figure 1

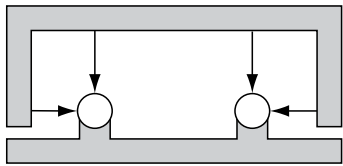

Figure 2

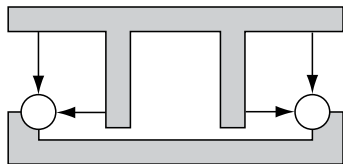

Figure 3

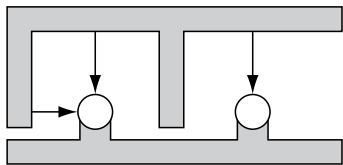

Figure 4

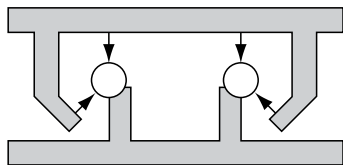

Figure 5

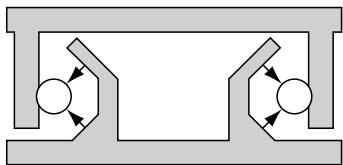

Figure 6

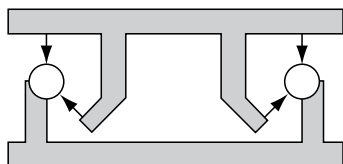

Figure 7

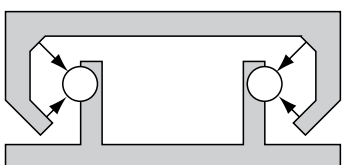

Figure 8

RoundWay Bearing Mounting Arrangements

RoundWay bearings are available in single mounting blocks or dual V-blocks. The basic race and roller assembly can be purchased separately, along with the suitable type of trunnion pin for mounting directly in the carriage or other machine elements (see page 113). When using either type of cantilever mounting trunnion pin, deflection may be experienced under heavy loads.

The above illustrations are a few schematic suggestions for arrangements of RoundWay bearings and 60 Case LinearRace ways. The load directions of the bearings are indicated by arrows.

The first group (Figs. 1 through 4) depends on gravity to hold the carriage on the ways.

The second group shows arrangements which will carry loads in any direction. The first two figures (Figs. 5 and 6) are similar to the second two figures (Figs. 7 and 8), except for reverse orientation of horizontal load-carrying bearings.

All schematics on this page can be pre-loaded except Fig. 1. In the Fig. 1 arrangement, the maximum side load permitted is 50% of the applied vertical load on the Dual RoundWay bearing.

IMPORTANT!

A single RoundWay bearing does not resist side loads. Therefore, dual RoundWay bearings or the equivalent are always used in combination with single units.

Inch – RoundWay Linear Roller Bearings

RoundWay Linear Roller Bearings for Continuously Supported Applications

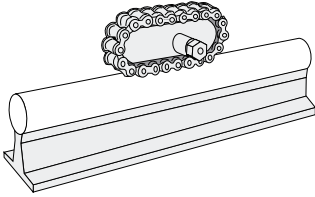

RoundWay Linear Roller Bearing Type (Type A,B,C)

- Available in 1/2 through 3 inch diameters.
- Load capacity range between 970 and 24,000 lb_r.
- Travel speeds up to 100 ft/s.
- Accelerations up to 450 ft/s².
- Can be adjusted to compensate for variations in the mounting surface.
- Self-aligning in all directions.
- Designed to compensate for two 60 Case LinearRace ways that are slightly out of parallel
- Can be mounted in a custom housing.
- Available with a two piece seal that retains lubrication while protecting the bearing from the ingress of dirt or contaminants.

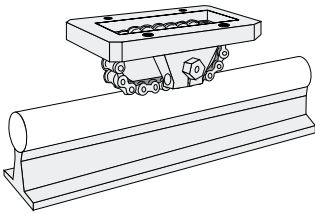

RoundWay Linear Roller Bearing (Single Type)

- Available in 1/2 through 3 inch diameters.
- Load capacity range between 970 and 24,000 lb_r.
- Travel speeds up to 100 ft/s.
- Accelerations up to 450 ft/s².
- Can be adjusted to compensate for variations in the mounting surface.
- Self-aligning in all directions.
- Designed to compensate for two 60 Case LinearRace ways that are slightly out of parallel
- Should always be used in conjunction with RoundWay Dual version.
- Can be mounted in a custom housing.
- Available with a two piece seal that retains lubrication while protecting the bearing from the ingress of dirt or contaminants.
- Easily mounted to carriage with four mounting bolts.

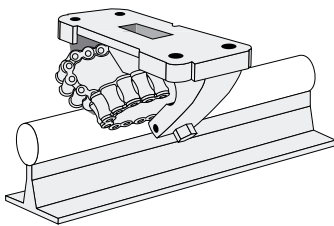

RoundWay Linear Roller Bearing (Dual Type)

- Available in 1/2 through 3 inch diameters.
- Load capacity range between 1370 and 35,000 lb_r.
- Travel speeds up to 100 ft/s.
- Accelerations up to 450 ft/s².
- Can be adjusted to compensate for variations in the mounting surface.
- Self-aligning in all directions.
- Available with a two piece seal that retains lubrication while protecting the bearing from the ingress of dirt or contaminants.
- Easily mounted to carriage with four mounting bolts.

Inch – RoundWay Linear Roller Bearings

RoundWay Linear Roller Bearing

Type A, B and C

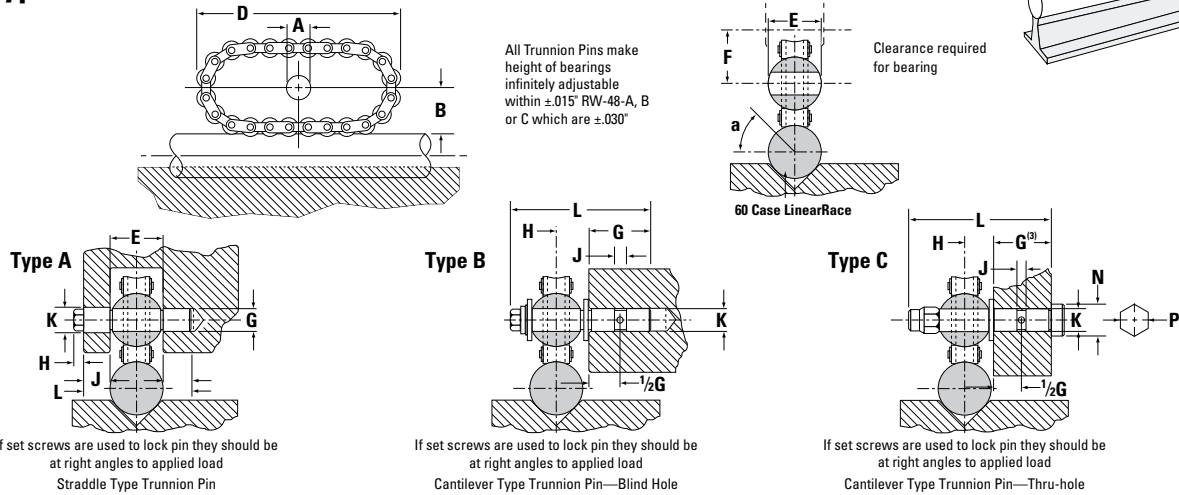

RoundWay Linear Roller Bearing (Type A, B and C) and 60 Case LinearRace (Dimensions in inches)

Part Number				Nom. Dia.	A +.0005 -.0000	B	C	D	E ±.001	F	α deg	60 Case LinearRace Diameter d	60 Case LinearRace Maximum Length	60 Case Solid LinearRace Mass lb/in	Dynamic (1) Load Capacity lb _i
Bearing Type A	Bearing Type B	Bearing Type C	60 Case LinearRace												
RW8A	RW8B	RW8C	1/2 L PD	.500	.2500	.45	.63	2.38	.502	.56	50	.4995/.4990	168	.06	970
RW16A	RW16B	RW16C	1 L PD	1.000	.4688	.80	1.00	3.75	1.002	.94	50	.9995/.9990	180	.22	3020
RW24A	RW24B	RW24C	1 1/2 L PD	1.500	.7188	1.15	1.50	5.38	1.502	1.38	55	1.4994/1.4989	204	.50	6020
RW32A	RW32B	RW32C	2 L PD	2.000	.9688	1.50	2.00	7.38	2.002	1.75	55	1.9994/1.9987	204	.89	12360
RW48A	RW48B	RW48C	3 L PD ⁽²⁾	3.000	1.5626	2.30	3.00	11.00	3.002	2.75	50	2.9992/2.9983	204	2.00	24000

RW-64-A

Trunion Type A

Round Way Bearing Part Number	G	H	J	K +.0000 -.0005	L	Bearing Mass lb
RW8A	.2187	.19	.31	.2812	1.13	.30
RW16A	.4375	.25	.50	.5000	2.00	1.10
RW24A	.6875	.31	.63	.7500	2.75	3.10
RW32A	.9375	.38	.75	1.0000	3.50	7.3
RW48A	1.5000	.59	1.25	1.6250	5.53	24.0
RW64A						

Trunion Type B

Round Way Bearing Part Number	G ⁽²⁾ +.0000 -.0005	H	J	K +.000 -.001	L	Bearing Mass lb
RW8B	.75	.31	.13	.3105	1.63	.30
RW16B	1.25	.59	.19	.498	2.78	1.10
RW24B	1.75	.88	.25	.748	3.94	3.10
RW32B	2.25	1.13	.31	.998	5.06	7.70
RW48B	3.50	1.75	.50	1.623	8.00	24.80

Trunion Type C

Round Way Bearing Part Number	G ⁽²⁾ +.060 -.000	H	J	K +.000 -.001	L	M	N	P Std. Hex across Flats	Bearing Mass lb
RW8C	.719	.31	.13	.311	1.69	.22	.44	—	.30
RW16C	1.188	.59	.19	.498	2.88	.31	.75	—	1.10
RW24C	1.656	.88	.25	.748	4.13	.50	1.00	—	3.20
RW32C	2.094	1.13	.31	.998	5.25	.63	1.31	—	7.90
RW48C	3.063	1.75	.50	1.623	7.25	1.00	—	2.25	25.60

(1) Dynamic Load Capacity is based on 10 million inches of travel. (2) Thickness of mounting member.

Load/Life Graph (Lines indicate limiting load for given RoundWay bearing)

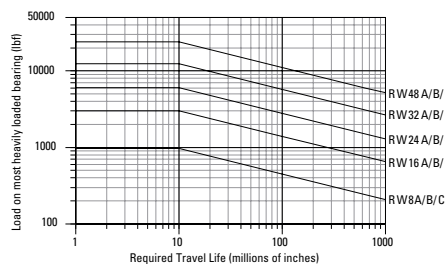

Determining RoundWay Bearing Size

The primary factors that influence the choice of bearing size are maximum load on a single RoundWay bearing and the required travel life. To determine the proper RoundWay bearing size enter the chart with the maximum load of the most heavily loaded bearing and the required travel life. Mark where the two lines intersect. All RoundWay bearing sizes that pass through or above and to the right of this point may be suitable for this application.

Inch – RoundWay Linear Roller Bearings

RoundWay Linear Roller Bearing (Single Type)

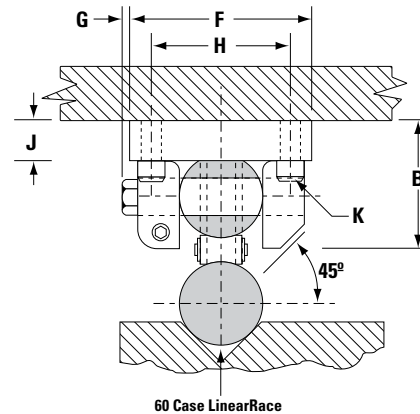
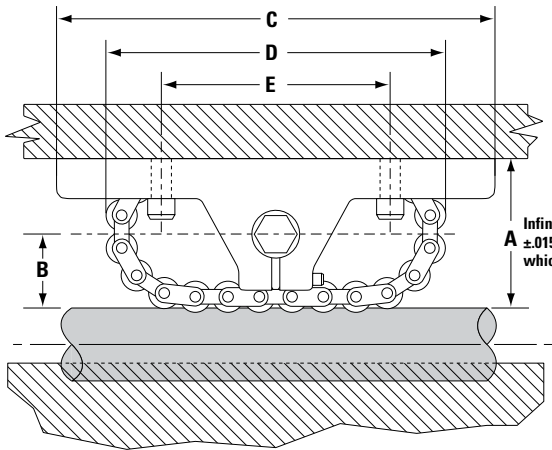
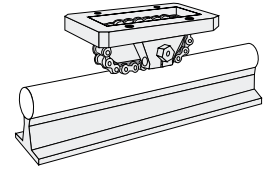

RoundWay Linear Roller Bearing (Single Type) and 60 Case LinearRace (Dimensions in inches)

Part Number		Nom. Dia.	A	B	C	D	E	F	G	H	J	K		L	60 Case LinearRace Diameter d	60 Case LinearRace Maximum Length	60 Case Solid LinearRace Mass lb/in	Bearing Mass lb	Dynamic ⁽¹⁾ Load Capacity lb _f
RoundWay Bearing	60 Case LinearRace											Bolt	Hole						
RW8S	1/2 L PD	.500	1.00	.45	3.0	2.38	1.50	1.25	.19	.94	.31	#6	.16	.88	.4995/.4990	168	.06	.50	970
RW16S	1 L PD	1.000	1.75	.80	5.0	3.75	2.50	2.13	.25	1.63	.50	#10	.25	1.50	.9995/.9990	180	.22	2.20	3020
RW24S	1 1/2 L PD	1.500	2.50	1.15	6.5	5.38	3.50	2.88	.31	2.13	.63	.31	.38	2.13	1.4994/1.4989	204	.50	5.60	6020
RW32S	2 L PD	2.000	3.25	1.50	8.5	7.38	4.50	3.63	.38	2.75	.75	.38	.44	2.88	1.9994/1.9987	204	.89	12.40	12360
RW48S	3 L PD	3.000	5.00	2.30	13.0	11.00	7.00	6.00	.50	4.25	1.25	.63	.69	4.25	2.9992/2.9983	204	2.00	48.00	24000
RW64S	4 L PD	4.000	6.50	3.00	17.0	14.88	9.00	7.75	.50	5.50	1.50	.75	.81	5.88	3.9988/3.9976	202	3.56	105.00	48000

(1) Dynamic Load Capacity is based on 10 million inches of travel.

Load/Life Graph

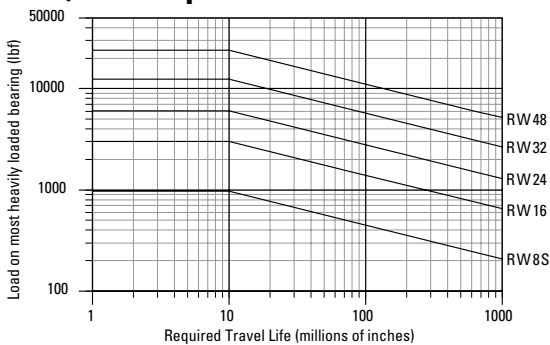

(Lines indicate limiting load for given RoundWay bearing)

Determining RoundWay Bearing Size

The primary factors that influence the choice of bearing size are maximum load on a single RoundWay bearing and the required travel life. To determine the proper RoundWay bearing size enter the chart with the maximum load of the most heavily loaded bearing and the required travel life. Mark where the two lines intersect. All RoundWay bearing sizes that pass through or above and to the right of this point may be suitable for this application.

Inch – RoundWay Linear Roller Bearings

RoundWay Linear Roller Bearing (Dual Type)

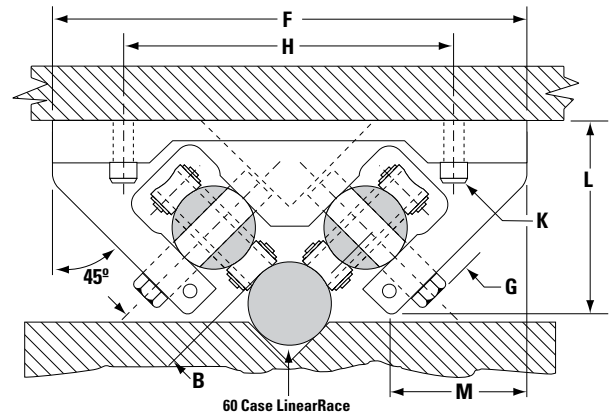
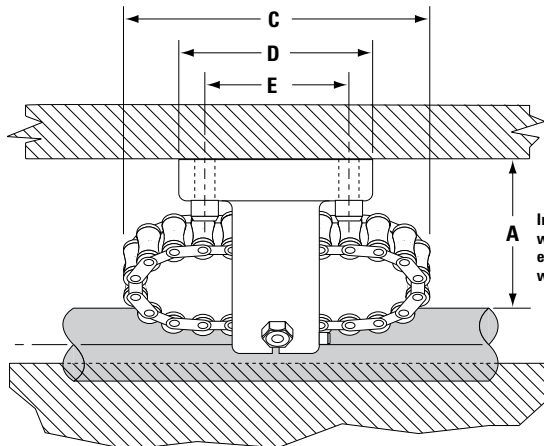
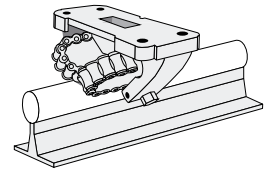

RoundWay Linear Roller Bearing (Dual Type) and 60 Case LinearRace (Dimensions in inches)

Part Number		Nom. Dia.	A	B	C	D	E	F	G	H	J	K		L	M	60 Case LinearRace Diameter d	60 Case LinearRace Maximum Length	60 Case Solid LinearRace Mass lb/in	Bearing Mass lb	Dynamic ⁽¹⁾ Load Capacity lb _f
RoundWay Bearing	60 Case LinearRace											Bolt	Hole							
RW8V	1/2 L PD	.500	1.00	.45	2.38	1.38	1.00	3.00	.19	2.25	.31	#8	.19	1.38	.69	.4995/.4990	168	.06	1.10	1370
RW16V	1 L PD	1.000	1.75	.80	3.75	2.25	1.63	5.75	.25	4.0	.50	#10	.25	2.38	1.56	.9995/.9990	180	.22	4.90	4300
RW24V	1 1/2 L PD	1.500	2.50	1.15	5.38	2.75	2.00	7.88	.31	6.0	.63	.31	.38	3.38	2.13	1.4994/1.4989	204	.50	11.70	8600
RW32V	2 L PD	2.000	3.25	1.50	7.38	3.50	2.50	9.75	.38	7.5	.75	.38	.44	4.33	2.50	1.9994/1.9987	204	.89	25.20	17500
RW48V	3 L PD	3.000	5.00	2.30	11.00	5.50	4.00	15.50	.63	12	1.25	.63	.69	6.69	4.25	2.9992/2.9983	204	2.00	90.00	35000
RW64V	4 L PD	4.000	6.50	3.00	14.88	7.00	5.00	19.25	.75	15	1.50	.75	.81	8.63	5.00	3.9988/3.9976	204	3.56	193.00	70000

(1) Dynamic Load Capacity is based on 10 million inches of travel.

Load/Life Graph

(Lines indicate limiting load for given RoundWay bearing)

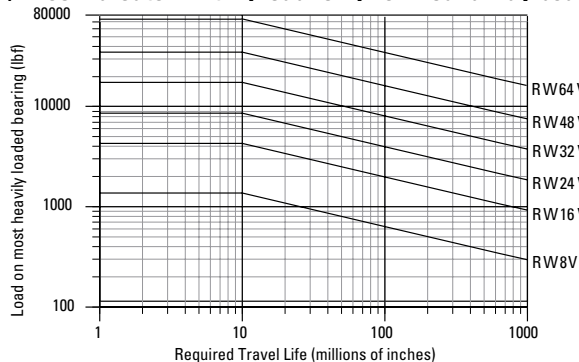

Determining RoundWay Bearing Size

The primary factors that influence the choice of bearing size are maximum load on a single RoundWay bearing and the required travel life. To determine the proper RoundWay bearing size enter the chart with the maximum load of the most heavily loaded bearing and the required travel life. Mark where the two lines intersect. All RoundWay bearing sizes that pass through or above and to the right of this point may be suitable for this application.

Inch – RoundWay Linear Roller Bearings

Overhead Carriage for Log-Processing Machine

Objective

Design overhead carriage system using RoundWay linear roller bearings mounted on 60 Case LinearRace ways.

Solution

RoundWay linear roller bearings' high load capacity will be used to move heavy logs into and out of the band saws. The carriages shuttle back and forth on 100 foot long 60 Case LinearRace ways until the final cut is made.

Products specified

- 2 - RW32V (RoundWay Linear Roller bearing Dual Type)
- 2 - RW32S (RoundWay Linear Roller bearing Single Type)
- 2 - 2 L PD CTL x 100 ft (60 Case LinearRace)

Benefits

RoundWay linear roller bearings provide operating speeds up to 100 ft/s, optimizing productivity and minimizing cost. The RoundWay bearings' low coefficient of friction allows the use of smaller, less expensive drive motors, belts, linkages and gears. The seal keeps out wood chips and other contaminants and maximizes bearing life.

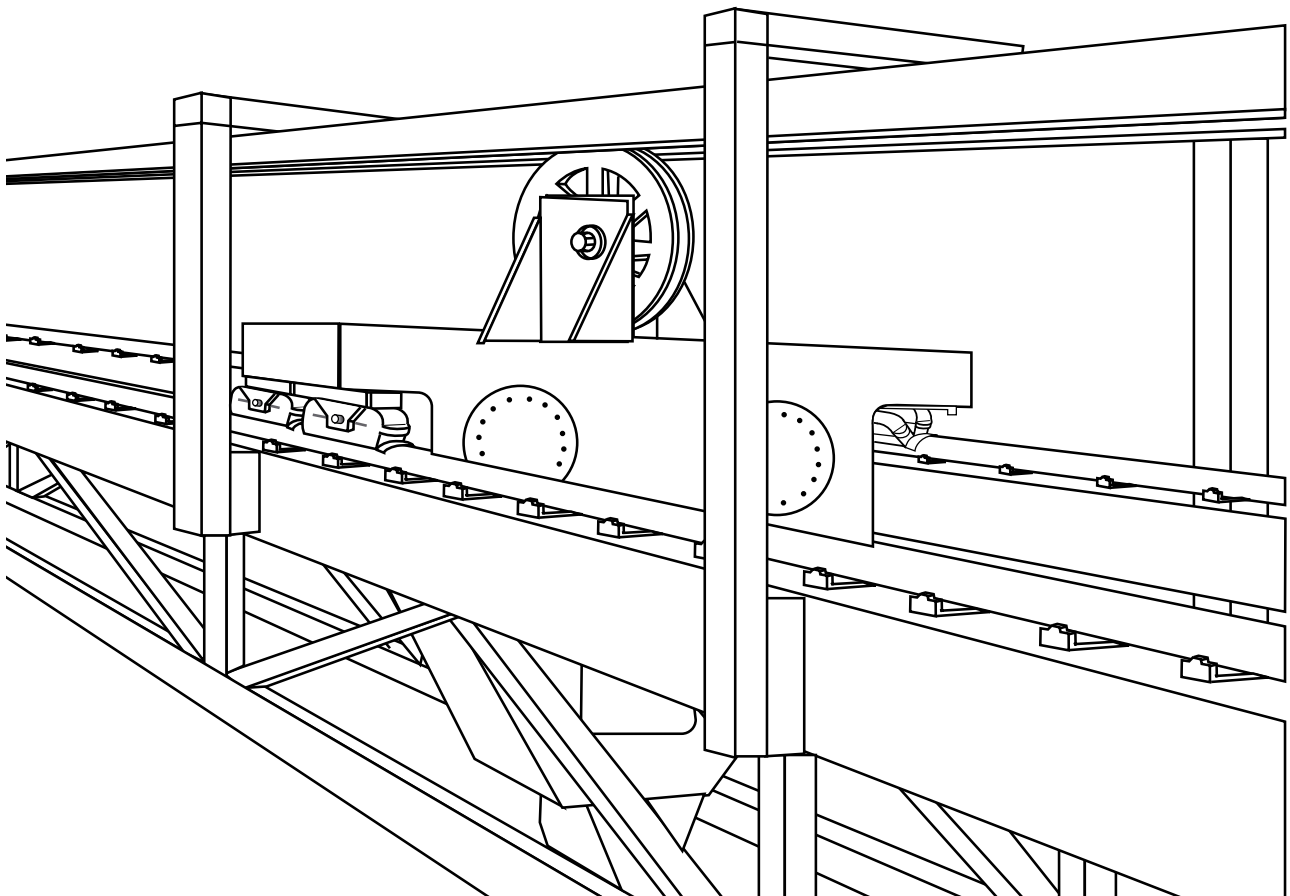

Inch – FluoroNyliner Bushing Bearings

FluoroNyliner Bushing Bearings



Thomson FluoroNyliner Bushing Bearings offer:

- High performance in contaminated, washdown, or submerged environments
- Proprietary, self-lubricating, composite bearing liner TEP 950
- Low friction, ideally suited for linear and rotary motion
- Precision machined aluminum sleeve
- Excellent performance in high vibration and mechanical shock applications
- Corrosion resistance
- Product availability in industry standard sizes from 0.25" to 2.00"
- Eight bearing configurations, include closed, open, self-aligning, precision and compensated IDs
- Load capacities up to 14,000 lb_f
- Integral seals
- Closed, Open, and Flanged Pillow Blocks available in single or twin versions
- Available from over 1800 distributors worldwide

Inch – FluoroNyliner Bushing Bearings

FluroNyliner Bushing Bearings

Common Specifications

Nominal Bearing Diameter (in.)	60 Case LinearRace Shafting			Recommended Shaft Diameter (in.)		Weight (lbs.)	Effective Surface Area (in ²)	Max. Static Load ¹ (lb.)
	Carbon Steel	316 Stainless Steel	Aluminum Inputs	Min.	Max.			
.250	1/4 L	1/4 L 316 SS	1/4 AL	.2490	.2495	.008	.19	300
.375	3/8 L	3/8 L 316 SS	3/8 AL	.3740	.3745	.013	.33	500
.500	1/2 L	1/2 L 316 SS	1/2 AL	.4990	.4995	.030	.63	970
.625	5/8 L	5/8 L 316 SS	5/8 AL	.6240	.6245	.072	.94	1450
.750	3/4 L	3/4 L 316 SS	3/4 AL	.7490	.7495	.090	1.22	1900
1.000	1 L	1 L 316 SS	1 AL	.9990	.9995	.190	2.25	3500
1.250	1 1/4 L	1 1/4 L 316 SS	-	1.2490	1.2495	.380	3.28	5100
1.500	1 1/2 L	1 1/2 L 316 SS	-	1.4989	1.4994	.610	4.51	7000
2.000	2 L	2 L 316 SS	-	1.9987	1.9994	1.230	8.01	12500

(1) Open bearings operating in shear should be derated by 40%. Open bearings operating in tension should be derated by 70%.

Closed Bearing

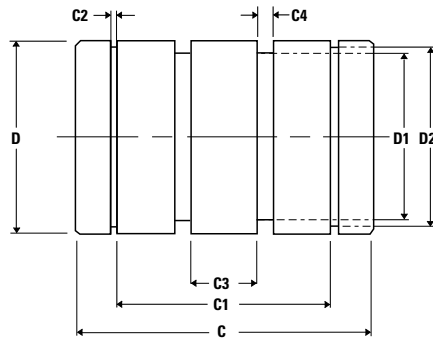

Side View

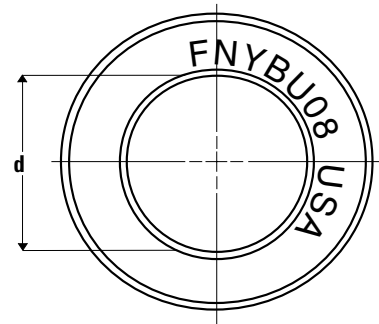

Front View

Self-Aligning Bearing

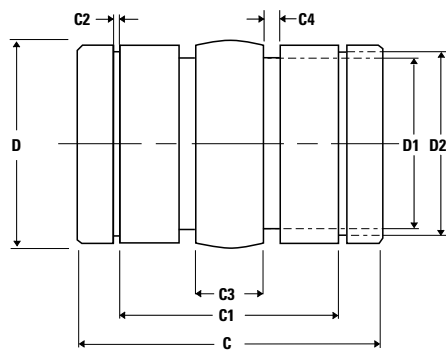

Side View



Inch – FluoroNyliner Bushing Bearings

Standard Bearings

Precision I.D.			Compensated I.D. ¹				Closed Bearing Dimensions (in.)									
Part Number	d (in.)		Part Number	d (in.)		Nom. Bearing Dia.	D		D1	D2	C		C1 Min.	C2 Min.	C3	C4
	Min.	Max.		Min.	Max.		Min.	Max.			Min.	Max.				
FNYBU04	0.2505	0.2515	FNYBU04L	0.2530	0.2540	0.250	0.4990	0.5000	0.395	0.467	0.735	0.750	0.437	0.040	0.180	0.085
FNYBU06	0.3755	0.3765	FNYBU06L	0.3780	0.3780	0.375	0.6240	0.6250	0.520	0.587	0.860	0.875	0.562	0.040	0.260	0.085
FNYBU08	0.5005	0.5015	FNYBU08L	0.5030	0.5040	0.500	0.8740	0.8750	0.710	0.820	1.235	1.250	0.875	0.048	0.490	0.118
FNYBU10	0.6255	0.6265	FNYBU10L	0.6280	0.6290	0.629	1.1240	1.1250	0.958	1.060	1.485	1.500	1.000	0.058	0.550	0.118
FNYBU12	0.7508	0.7518	FNYBU12L	0.7540	0.7550	0.750	1.2490	1.2500	1.085	1.175	1.610	1.625	1.062	0.058	0.612	0.118
FNYBU16	1.0008	1.0018	FNYBU16L	1.0040	1.0050	1.000	1.5615	1.5625	1.395	1.467	2.235	2.250	1.625	0.070	1.180	0.118
FNYBU20	1.2508	1.2518	FNYBU20L	1.2550	1.2560	1.250	1.9990	2.0000	1.835	1.885	2.610	2.625	1.875	0.070	1.425	0.118
FNYBU24	1.5008	1.5002	FNYBU24L	1.5050	1.5062	1.500	2.3735	2.3750	2.210	2.238	2.980	3.000	2.250	0.090	1.670	0.118
FNYBU32	2.0012	2.0027	FNYBU32L	2.0050	2.0074	2.000	2.9985	3.0000	2.750	2.837	3.980	4.000	3.000	0.105	1.450	0.155

Standard Self-Aligning Bearings

Precision I.D.			Compensated I.D. ¹				Closed Bearing Dimensions (in.)									
Part Number	d (in.)		Part Number	d (in.)		Nom. Bearing Dia.	D		D1	D2	C		C1 Min.	C2 Min.	C3	C4
	Min.	Max.		Min.	Max.		Min.	Max.			Min.	Max.				
FNYBU04A	0.2505	0.2515	FNYBU04AL	0.2530	0.2540	0.250	0.4990	0.5000	0.395	0.467	0.735	0.750	0.437	0.040	0.180	0.085
FNYBU06A	0.3755	0.3765	FNYBU06AL	0.3780	0.3780	0.375	0.6240	0.6250	0.520	0.587	0.860	0.875	0.562	0.040	0.260	0.085
FNYBU08A	0.5005	0.5015	FNYBU08AL	0.5030	0.5040	0.500	0.8740	0.8750	0.710	0.820	1.235	1.250	0.875	0.048	0.490	0.118
FNYBU10A	0.6255	0.6265	FNYBU10AL	0.6280	0.6290	0.629	1.1240	1.1250	0.958	1.060	1.485	1.500	1.000	0.058	0.550	0.118
FNYBU12A	0.7508	0.7518	FNYBU12AL	0.7540	0.7550	0.750	1.2490	1.2500	1.085	1.175	1.610	1.625	1.062	0.058	0.612	0.118
FNYBU16A	1.0008	1.0018	FNYBU16AL	1.0040	1.0050	1.000	1.5615	1.5625	1.395	1.467	2.235	2.250	1.625	0.070	1.180	0.118
FNYBU20A	1.2508	1.2518	FNYBU20AL	1.2550	1.2560	1.250	1.9990	2.0000	1.835	1.885	2.610	2.625	1.875	0.070	1.425	0.118
FNYBU24A	1.5008	1.5002	FNYBU24AL	1.5050	1.5062	1.500	2.3735	2.3750	2.210	2.238	2.980	3.000	2.250	0.090	1.670	0.118
FNYBU32A	2.0012	2.0027	FNYBU32AL	2.0050	2.0074	2.000	2.9985	3.0000	2.750	2.837	3.980	4.000	3.000	0.105	1.450	0.155

¹ Compensated I.D. bearings have additional running clearance, ideally suited for high speed and non-parallel shaft applications.

Inch – FluoroNyliner Bushing Bearings

Common Open Bearing Dimensions (in.)

Nominal Bearing Diameter (in.)	E	F	G	B	a(*)
.250	.094	.375	.125	.188	60
.375	.094	.438	.146	.250	60
.500	.136	.625	.000	.313	66
.625	.104	.125	.000	.375	60
.750	.136	.125	.000	.438	66
1.000	.136	.125	.000	.563	64
1.250	.201	.197	.000	.625	60
1.500	.201	.193	.000	.750	60
2.000	.265	.292	.000	1.000	60

Open Bearing

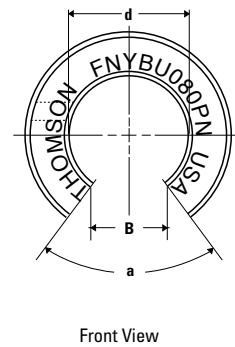
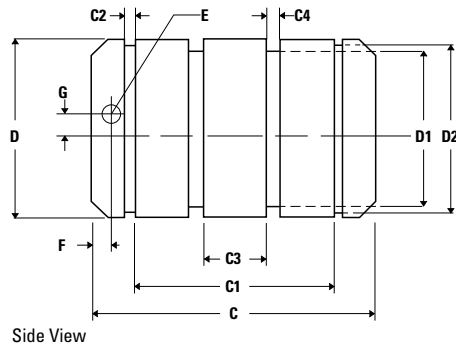

Self-Aligning Open Bearing

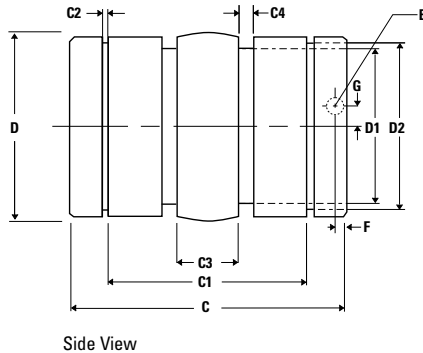
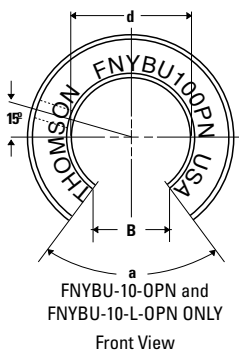

Inch – FluoroNyliner Bushing Bearings

Standard Open Bearings

Precision I.D.		Compensated I.D. ¹				Open Bearing Dimensions (in.)										
Part Number	d (in.)		Part Number	d (in.)		Nom. Bearing Dia.	D		D1	D2	C		C1 Min.	C2 Min.	C3	C4
	Min.	Max.		Min.	Max.		Min.	Max.			Min.	Max.				
FNYBU04OPN	0.2505	0.2515	FNYBU04LOPN	0.2530	0.2540	0.250	0.4990	0.5000	0.395	0.467	0.735	0.750	0.437	0.040	0.180	0.085
FNYBU06OPN	0.3755	0.3765	FNYBU06LOPN	0.3780	0.3780	0.375	0.6240	0.6250	0.520	0.587	0.860	0.875	0.562	0.040	0.260	0.085
FNYBU08OPN	0.5005	0.5015	FNYBU08LOPN	0.5030	0.5040	0.500	0.8740	0.8750	0.710	0.820	1.235	1.250	0.875	0.048	0.490	0.118
FNYBU10OPN	0.6255	0.6265	FNYBU10LOPN	0.6280	0.6290	0.629	1.1240	1.1250	0.958	1.060	1.485	1.500	1.000	0.058	0.550	0.118
FNYBU12OPN	0.7508	0.7518	FNYBU12LOPN	0.7540	0.7550	0.750	1.2490	1.2500	1.085	1.175	1.610	1.625	1.062	0.058	0.612	0.118
FNYBU16OPN	1.0008	1.0018	FNYBU16LOPN	1.0040	1.0050	1.000	1.5615	1.5625	1.395	1.467	2.235	2.250	1.625	0.070	1.180	0.118
FNYBU20OPN	1.2508	1.2518	FNYBU20LOPN	1.2550	1.2560	1.250	1.9990	2.0000	1.835	1.885	2.610	2.625	1.875	0.070	1.425	0.118
FNYBU24OPN	1.5008	1.5002	FNYBU24LOPN	1.5050	1.5062	1.500	2.3735	2.3750	2.210	2.238	2.980	3.000	2.250	0.090	1.670	0.118
FNYBU32OPN	2.0012	2.0027	FNYBU32LOPN	2.0050	2.0074	2.000	2.9985	3.0000	2.750	2.837	3.980	4.000	3.000	0.105	1.450	0.155

Standard Self-Aligning Open Bearings

Precision I.D.		Compensated I.D. ¹				Self-Aligning Bearing Dimensions (in.)										
Part Number	d (in.)		Part Number	d (in.)		Nom. Bearing Dia.	D		D1	D2	C		C1 Min.	C2 Min.	C3	C4
	Min.	Max.		Min.	Max.		Min.	Max.			Min.	Max.				
FNYBU04AOPN	0.2505	0.2515	FNYBU04ALOPN	0.2530	0.2540	0.250	0.4990	0.5000	0.395	0.467	0.735	0.750	0.437	0.040	0.180	0.085
FNYBU06AOPN	0.3755	0.3765	FNYBU06ALOPN	0.3780	0.3780	0.375	0.6240	0.6250	0.520	0.587	0.860	0.875	0.562	0.040	0.260	0.085
FNYBU08AOPN	0.5005	0.5015	FNYBU08ALOPN	0.5030	0.5040	0.500	0.8740	0.8750	0.710	0.820	1.235	1.250	0.875	0.048	0.490	0.118
FNYBU10AOPN	0.6255	0.6265	FNYBU10ALOPN	0.6280	0.6290	0.629	1.1240	1.1250	0.958	1.060	1.485	1.500	1.000	0.058	0.550	0.118
FNYBU12AOPN	0.7508	0.7518	FNYBU12ALOPN	0.7540	0.7550	0.750	1.2490	1.2500	1.085	1.175	1.610	1.625	1.062	0.058	0.612	0.118
FNYBU16AOPN	1.0008	1.0018	FNYBU16ALOPN	1.0040	1.0050	1.000	1.5615	1.5625	1.395	1.467	2.235	2.250	1.625	0.070	1.180	0.118
FNYBU20AOPN	1.2508	1.2518	FNYBU20ALOPN	1.2550	1.2560	1.250	1.9990	2.0000	1.835	1.885	2.610	2.625	1.875	0.070	1.425	0.118
FNYBU24AOPN	1.5008	1.5002	FNYBU24ALOPN	1.5050	1.5062	1.500	2.3735	2.3750	2.210	2.238	2.980	3.000	2.250	0.090	1.670	0.118
FNYBU32AOPN	2.0012	2.0027	FNYBU32ALOPN	2.0050	2.0074	2.000	2.9985	3.0000	2.750	2.837	3.980	4.000	3.000	0.105	1.450	0.155

¹ Compensated I.D. bearings have additional running clearance, ideally suited for high speed and non-parallel shaft applications.

² Open bearings operating in shear should be derated by 40%. Open bearings operating in tension should be derated by 70%.

Inch – FluoroNyliner Bushing Bearings

FluoroNyliner Bushing Bearing Pillow Blocks



For the easiest installation, order Pillow Blocks with factory installed FluoroNyliner Bushing Bearings.

Three Pillow Block Configurations



Closed Bearing Pillow Blocks

- For end supported applications
- Choose twin pillow blocks for twice the load capacity
- Order with seals for heavily contaminated environments
- Available as single or twin pillow blocks



Open Bearing Pillow Blocks

- For continuously supported applications
- Choose compensated I.D. bearings for non-parallel shafting
- Order with seals for heavily contaminated environments
- Available as single or twin pillow blocks



Flanged Pillow Blocks with Closed Bearings

- For low profile applications such as packaging equipment
- Choose precision I.D. bearings for precision fit-up
- Available with self-aligning or compensated I.D. bearings
- Available as single or twin pillow blocks

Inch – FluoroNyliner Bushing Bearings

Closed Pillow Blocks with Self-Aligning Bearings

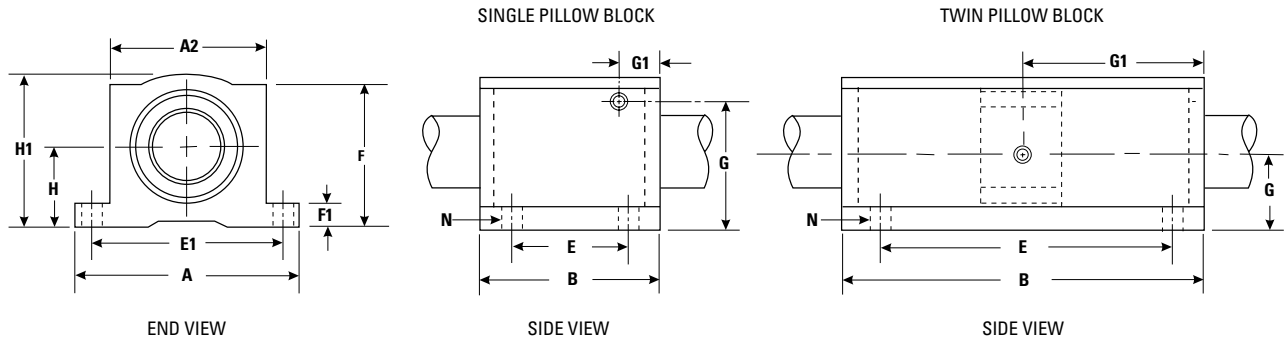

Closed Single Pillow Blocks with Self-Aligning Bearings

Precision I.D.	Compensated I.D. ¹	Single Pillow Block Dimensions (in.)														Pillow Block Mass (lb)	Max. Static Load (lb _v)
Part Number	Part Number	H ±.003	H1	A	A2	B	E ±.010	E1 ±.010	F	F1	G	G1	N				
													Hole	Bolt			
FNYBUPB04ALS	FNYBUPB04ALLS	.437	.81	1.63	1.00	1.19	.750	1.313	.75	.19	.60	.41	.16	#6	.10	300	
FNYBUPB06ALS	FNYBUPB06ALLS	.500	.94	1.75	1.13	1.31	.875	1.438	.88	.19	.70	.41	.16	#6	.13	500	
FNYBUPB08ALS	FNYBUPB08ALLS	.687	1.25	2.00	1.38	1.69	1.000	1.688	1.13	.25	.97	.44	.16	#6	.40	970	
FNYBUPB10ALS	FNYBUPB10ALLS	.875	1.63	2.50	1.75	1.94	1.125	2.125	1.44	.28	1.17	.68	.19	#8	1.00	1450	
FNYBUPB12ALS	FNYBUPB12ALLS	.937	1.75	2.75	1.88	2.06	1.250	2.375	1.56	.31	.94	.72	.19	#8	1.20	1900	
FNYBUPB16ALS	FNYBUPB16ALLS	1.187	2.19	3.25	2.38	2.81	1.750	2.875	1.94	.38	1.20	.86	.22	#10	2.40	3500	
FNYBUPB20ALS	FNYBUPB20ALLS	1.500	2.81	4.00	3.00	3.63	2.000	3.500	2.50	.44	1.50	1.20	.22	#10	5.00	5100	
FNYBUPB24ALS	FNYBUPB24ALLS	1.750	3.25	4.75	3.50	4.00	2.500	4.125	2.88	.50	1.75	1.25	.28	1/4	7.80	7000	
FNYBUPB32ALS	FNYBUPB32ALLS	2.125	4.06	6.00	4.50	5.00	3.250	3.250	3.63	.63	1.30	1.25	.41	1/4	7.80	12500	

Closed Twin Pillow Blocks with Self-Aligning Bearings

Precision I.D.	Compensated I.D. ¹	Twin Pillow Block Dimensions (in.)														Pillow Block Mass (lb)	Max. Static Load (lb _v)
Part Number	Part Number	H ±.003	H1	A	A2	B	E ±.010	E1 ±.010	F	F1	G	G1	N				
													Hole	Bolt			
FNYBUTWN04ALS	FNYBUTWN04ALLS	.437	.81	1.63	1.00	2.50	2.000	1.313	.75	.19	.60	.41	.16	#6	.19	600	
FNYBUTWN06ALS	FNYBUTWN06ALLS	.500	.94	1.75	1.13	2.75	2.050	1.438	.88	.19	.70	.41	.16	#6	.25	1000	
FNYBUTWN08ALS	FNYBUTWN08ALLS	.687	1.25	2.00	1.38	3.50	2.000	1.688	1.13	.25	.97	.44	.16	#6	.40	1940	
FNYBUTWN10ALS	FNYBUTWN10ALLS	.875	1.63	2.50	1.75	4.00	3.000	2.125	1.44	.28	1.17	.68	.19	#8	1.00	2900	
FNYBUTWN12ALS	FNYBUTWN12ALLS	.937	1.75	2.75	1.88	4.50	3.500	2.375	1.56	.31	.94	.72	.19	#8	1.20	3800	
FNYBUTWN16ALS	FNYBUTWN16ALLS	1.187	2.19	3.25	2.38	6.00	4.500	2.875	1.94	.38	1.20	.86	.22	#10	2.40	7000	
FNYBUTWN20ALS	FNYBUTWN20ALLS	1.500	2.81	4.00	3.00	7.50	5.500	3.500	2.50	.44	1.50	1.20	.22	#10	5.00	10200	
FNYBUTWN24ALS	FNYBUTWN24ALLS	1.750	3.25	4.75	3.50	9.00	6.500	4.125	2.88	.50	1.75	1.25	.28	1/4	7.80	14000	

¹ Compensated I.D. bearings have additional running clearance, ideally suited for high speed and non-parallel shaft applications.

² All dimensions in inches unless otherwise noted.

Note: For Pillow Block Seals or non-self-aligning bearings see Part Number Matrix on page 113.

Inch – FluoroNyliner Bushing Bearings

Open Pillow Blocks with Self-Aligning Bearings

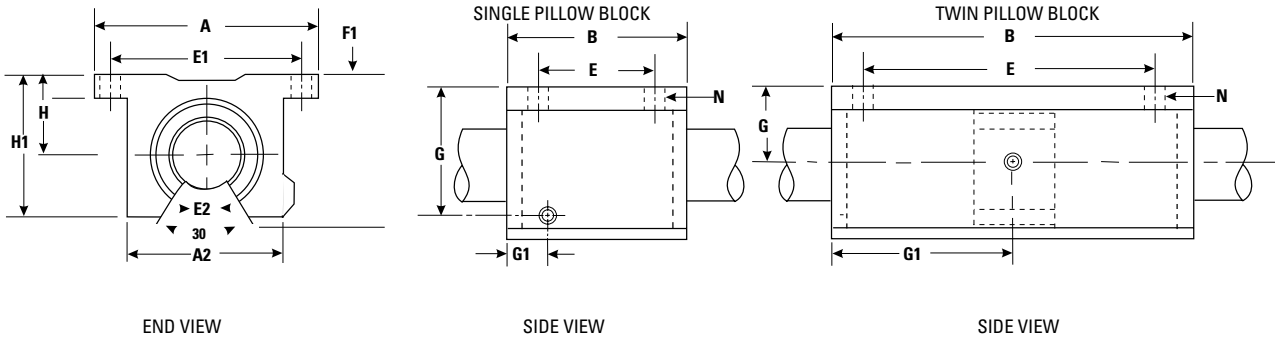

Open Single Pillow Blocks with Self-Aligning Bearings

Precision I.D.	Compensated I.D. ¹	Single Pillow Block Dimensions (in.)													
Part Number	Part Number	H ±.003	H1	A	A2	B	E ±.010	E1 ±.010	F1	G	G1	N		Pillow Block Mass (lb)	Max. Static Load (lb.)
												Hole	Bolt		
FNYBUPB008ALS	FNYBUPB008ALLS	.687	1.13	2.00	1.38	1.69	1.000	1.688	.25	.69	.84	.16	#6	.20	970
FNYBUPB010ALS	FNYBUPB010ALLS	.875	1.44	2.50	1.75	1.94	1.125	2.125	.28	.70	.68	.19	#8	.50	1450
FNYBUPB012ALS	FNYBUPB012ALLS	.937	1.56	2.75	1.88	2.06	1.250	2.375	.31	.94	.72	.19	#8	.60	1900
FNYBUPB016ALS	FNYBUPB016ALLS	1.187	2.00	3.25	2.38	2.81	1.750	2.875	.38	1.20	.86	.22	#10	1.20	3500
FNYBUPB020ALS	FNYBUPB020ALLS	1.500	2.56	4.00	3.00	3.63	2.000	3.500	.44	1.50	1.20	.22	#10	2.50	5100
FNYBUPB024ALS	FNYBUPB024ALLS	1.750	2.94	4.75	3.50	4.00	2.500	4.125	.50	1.75	1.25	.28	1/4	3.80	7000
FNYBUPB032ALS	FNYBUPB032ALLS	2.125	3.63	6.00	4.50	5.00	3.250	5.250	.63	2.12	1.58	.41	3/8	7.00	12500

Open Twin Pillow Blocks with Self-Aligning Bearings

Precision I.D.	Compensated I.D. ¹	Twin Pillow Block Dimensions (in.)													
Part Number	Part Number	H ±.003	H1	A	A2	B	E ±.010	E1 ±.010	F1	G	G1	N		Pillow Block Mass (lb)	Max. Static Load (lb.)
												Hole	Bolt		
FNYBUTWN008ALS	FNYBUTWN008ALLS	.687	1.13	2.00	1.38	3.50	2.000	1.688	.25	.59	1.75	.16	#6	.40	1940
FNYBUTWN010ALS	FNYBUTWN010ALLS	.875	1.44	2.50	1.75	4.00	3.000	2.125	.28	.85	2.00	.19	#8	1.00	2900
FNYBUTWN012ALS	FNYBUTWN012ALLS	.937	1.56	2.75	1.88	4.50	3.500	2.375	.31	.94	2.25	.19	#8	1.20	3800
FNYBUTWN016ALS	FNYBUTWN016ALLS	1.187	2.00	3.25	2.38	6.00	4.500	2.875	.38	1.20	3.00	.22	#10	2.40	7000
FNYBUTWN020ALS	FNYBUTWN020ALLS	1.500	2.56	4.00	3.00	7.50	5.500	3.500	.44	1.50	3.75	.22	#10	5.00	10200
FNYBUTWN024ALS	FNYBUTWN024ALLS	1.750	2.94	4.75	3.50	9.00	6.500	4.125	.50	1.75	4.50	.28	1/4	7.80	14000

1 Compensated I.D. bearings have additional running clearance, ideally suited for high speed and non-parallel shaft applications.

2 All dimensions in inches unless otherwise noted.

3 Open bearings operating in shear should be derated by 40%. Open bearings operating in tension should be derated by 70%.

Note: For Pillow Block Seals or non-self-aligning bearings see Part Number Matrix on page 113.

Inch – FluoroNyliner Bushing Bearings

Flanged Pillow Blocks with Self-Aligning Bearings

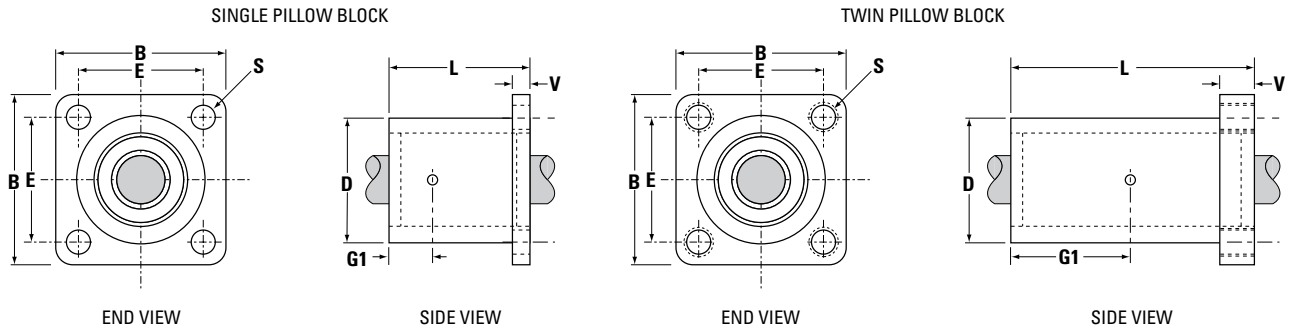

Flanged Single Pillow Blocks with Self-Aligning Bearings

Precision I.D.	Compensated I.D. ¹	Single Pillow Block Dimensions (in.)									
Part Number	Part Number	Nominal Bearing Diameter	B	E ±.010	L	D	V	G1 ±.010	S Shaft Hole Diameter	60 Case LinearRace Shaft Diameter	
										Min.	Mx.
FNYBUF08ALS	FNYBUF08ALLS	.500	1.63	1.250	1.69	1.25	.25	.72	.19	.4990	.4995
FNYBUF12ALS	FNYBUF12ALLS	.750	2.38	1.750	2.06	1.75	.38	.89	.22	.7490	.7495
FNYBUF16ALS	FNYBUF16ALLS	1.00	2.75	2.125	2.81	2.25	.50	1.27	.28	.9990	.9995
FNYBUF20ALS	FNYBUF20ALLS	1.25	3.50	2.750	3.63	3.00	.63	1.67	.35	1.2490	1.2495
FNYBUF24ALS	FNYBUF24ALLS	1.50	4.00	3.125	4.00	3.62	.75	1.86	.41	1.4989	1.4994

Flanged Twin Pillow Blocks with Self-Aligning Bearings

Precision I.D.	Compensated I.D. ¹	Twin Pillow Block Dimensions (in.)									
Part Number	Part Number	Nominal Bearing Diameter	B	E ±.010	L	D	V	G1 ±.010	S Thread	60 Case LinearRace Shaft Diameter	
										Min.	Mx.
FNYBUTFB08ALS	FNYBUTFB08ALLS	.500	1.63	1.250	3.20	1.25	.90	1.48	1/4 - 20	.4990	.4995
FNYBUTFB12ALS	FNYBUTFB12ALLS	.750	2.38	1.750	3.95	1.75	.90	1.98	1/4 - 20	.7490	.7495
FNYBUTFB16ALS	FNYBUTFB16ALLS	1.00	2.75	2.125	5.33	2.25	.90	2.67	1/4 - 18	.9990	.9995
FNYBUTFB20ALS	FNYBUTFB20ALLS	1.25	3.50	2.750	6.70	3.00	.90	3.35	5/16 - 18	1.2490	1.2495
FNYBUTFB24ALS	FNYBUTFB24ALLS	1.50	4.00	3.125	7.50	3.62	.100	3.75	5/16 - 16	1.4989	1.4994

1 Compensated I.D. bearings have additional running clearance, ideally suited for high speed and non-parallel shaft applications.

2 All dimensions in inches unless otherwise noted.

Note: For Pillow Block Seals or non-self-aligning bearings see Part Number Matrix at bottom of this page.

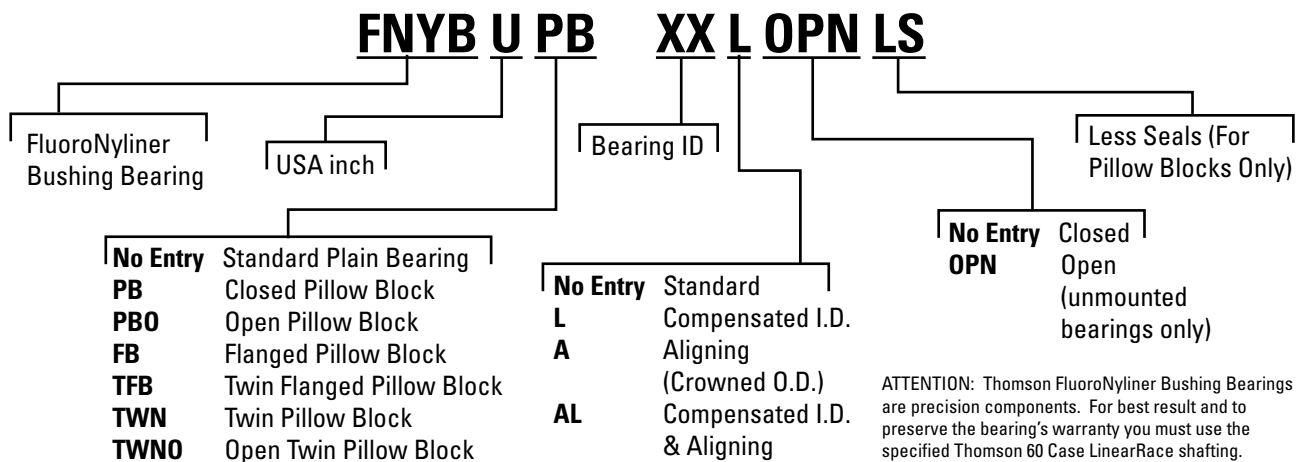

Inch – FluoroNyliner Bushing Bearings

Frictional Characteristics:

I) Static: Tests performed on dry FNYBU16 bearings indicate that the force required to initiate motion is dependent upon the applied load according to the following equation:

$$F_f = 1.3 + 0.18 F_a$$

Where:

F_f = Friction force, static (lb_f)

F_a = Applied force (lb_f)

Characteristic	Limit
Linear Temperature Range	-400° F to 550° F (-240° C to 288° C)
Velocity, dry	140 ft/min. Continuous
Velocity, dry	400 ft/min. Intermittent
Velocity, Lubricated	400 ft/min. Continuous
Pressure	1500 psi
PV	10,000 psi ft/min

II) Dynamic: The coefficient of friction is dependent upon both the pressure and the velocity.

Pressure: Coefficient of friction decreases rapidly with increase in pressure.

Velocity: Coefficient of friction increases with an increase in velocity, and quickly stabilizes.

For example, at 100 psi, the coefficient of friction is approximately 0.25 for velocities of 100ft/min and higher.

COEFFICIENT OF FRICTION VS. LOAD
(AT LOW SPEEDS)

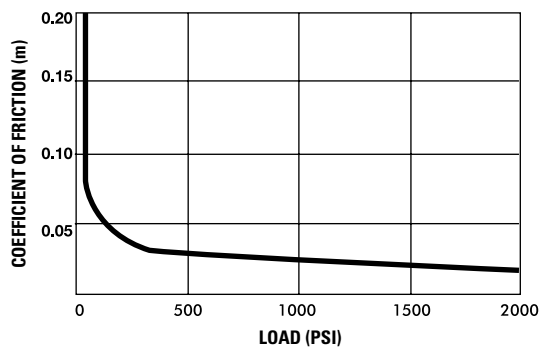

COEFFICIENT OF FRICTION VS. SPEED
(AT 100 P.S.I.)

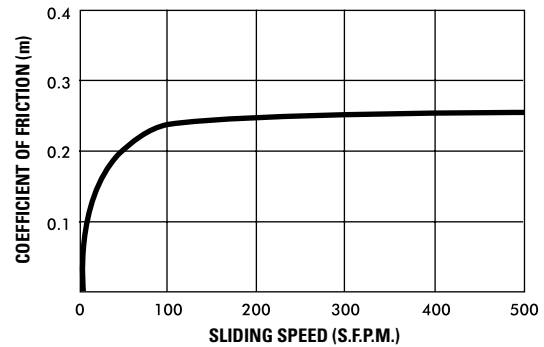

Wear Rates and Life Expectancy:

I) Wear rates: The wear rates of a plain bearing are dependent upon a number of variables, including characteristics of the counter-face, velocity, lubrication, load and contamination. Tests conducted on FNYBU16 bearings operating in the linear mode at approximately 70 ft/min, and at a pressure of approximately 33 psi, demonstrated an average radial wear change of 0.0011 inches, after 80 million inches of travel. This yields the following formula:

$$W_r = 14 \times (10^{-6}) \times T$$

Where:

W_r = Radial Wear (micro-inches)

T = Travel (inches)

II) Life expectancy: The life expectancy may be calculated from the wear rate. This is normally associated with the allowable radial clearance for a given application. The absolute wear limit is the bearing material thickness, which is 0.028 inches.

Inch – FluoroNyliner Bushing Bearings

FluoroNyliner Bushing Bearing Chemical Resistance Chart

Chemical	Rating **		
	Part Number	Standard Aluminum	Optional Hardcoat Anodized Aluminum
2-butanone	A		
Acetic Acid, 20%	A	C	C
Acetone	A	B	B
Acetylene	A		
Alkalines	E		
Ammonia	E		
Ammonia Anhydrous		B	B
Ammonium Chloride, 10%		D	D
Ammonium Hydroxide, 10%		D	D
Amyl Chloride	A		
Aniline	A		
Barium Hydroxide		D	D
Beer	A	B	B
Benzaldehyde or Benzonitrile	A		
Benzenesulfonic Acid	A	A	A
Boric Acid Solutions	A	B	B
Bromine	A		
Butane		C	C
Calcium Chloride, 20%	A	C	C
Calcium Hydroxide, 10%	E	C	C
Calcium Hypochlorite	A	C	C
Camphor Oil or Carbon Sulfide	A		
Carbon Dioxide	A		
Carbon Monoxide	A	B	B
Carbon Tetrachloride	A	B	B
Chloral Hydrate or Chloroacetic Acid	A		
Chlorine gas, dry	A	C	C
Chlorine gas, wet	A	D	D
Chloroform or Chlorosulfonic Acid	A		
Chromic Acid, 10%	A	C	B
Citric Acid, 5%	A	B	B
Concentrated Oxidizing Acids	A		
Creosote or Cresol	A		
Decalin or Dichlorobenzene	A		
Diethyl Ether or Dimethylamine	A		
Dimethyl Sulfoxide	A		
Ethyl Acetate	A		
Ethyl Alcohol	A	B	B
Ethylene Glycol	A	B	B
Ferric Chloride, 50%	A	D	D
Ferric Nitrate	A		
Ferric Sulfate	A		
Ferrous Sulfate	A		
Fluoboric Acid	E		
Fluorinating Agents, strong	E		
Fluorine > 140°F & dry gas > 250°F	E		
Fluosilicic Acid	E		
Gasoline	A	C	C
Hydrobromic Acid	A		

Chemical	Rating **		
	Part Number	Standard Aluminum	Optional Hardcoat Anodized Aluminum
Hydrochloric Acid, 20% or 35%	A	D	D
Hydrocyanic Acid	A	D	D
Hydrocyanic Acid, 10%		C	C
Hydrofluoric Acid	E	D	D
Hydrofluosilicic Acid	E		
Hydrogen Fluoride, dry > 250°F	E		
Hydrogen Peroxide - dilute	A	B	B
Hydrogen Sulfide, dry	A	C	B
Hydrogen Sulfide, moist	A		
Hydroxides	E		
Kerosene		C	C
Lactic Acid, 10%	A	C	C
Magnesium Chloride, 50%	A	D	D
Mercury or Silver Salts	A	D	D
Methyl Alcohol		C	C
Methylene Chloride	A	B	B
Methylethyl Ketone	A	C	C
Mineral Oil	A	C	C
Molten Alkali Metals	E		
Molten Anhydrous Base	E		
Naptha	A	C	C
Nitric Acid, 70%	E	D	D
Nitro Benzene	A		
Oleum	A		
Phosphoric Acid, 10%	A	D	D
Potassium Chlorate	E		
Potassium or Sodium Cyanide	A		
Potassium Dichromate or Nitrate	A		
Potassium Hydroxide	E		
Sea Water	A	C	B
Sodium Chlorate	A		
Sodium Chloride	A		
Sodium Hydroxide, 20%	C	D	D
Sodium Hypochlorite, 20%	A	C	C
Sodium Peroxide, 10%		C	C
Stannous Chloride	A		
Sulfur Dioxide, dry	A	C	C
Sulfur Dioxide, 5% +H ₂ O	A	D	D
Sulfuric Acid, 50%	A	D	D
Trichlorethylene	A		
Toluene (122°F/50°C)	A	B	B
Trifluoroacetic Acid	A		
Turpentine	A	C	B
Water, demineralized	A	C	B
Water, distilled	A	D	C
Water, sewage		D	C
Xylene	A	C	C
Zinc Chloride solutions	A	D	D

** Rating Key

A = No Attack B = Minimal Material Loss C = Moderate Material Loss D = Significant Material Loss E = Not Recommended
 Chemical effects are at room temperature unless otherwise noted.

All information contained herein is believed to be correct but is presented without any guaranty, warranty or representation of any kind, express or implied. Changes in temperature, concentration and/or combinations of chemicals may cause different results. Prior to use, it is recommended that the material be tested to determine its compatibility with a specific application. Contact Thomson applications engineers for more detailed information at 1-540-633-3549.

Inch – FluoroNyliner Bushing Bearings

New Thomson Food Grade FluoroNyliner Bushing Bearings



Description

Thomson Food Grade FluoroNyliner Bushing Bearings are the first stainless steel, corrosion resistant self lubricating bushing bearing with FDA compliant liner materials. They are designed for use in food processing, pharmaceutical and medical applications.

The corrosion resistant sleeve is stainless steel, while the self lubricating liner is FDA and USDA compliant.

As the bearing does not utilize ball bearings, it can be run on soft shafting such as Thomson "corrosion proof" 316 Stainless Steel or Ultra Light Aluminum LinearRace shafting, making the Food Grade FluoroNyliner excel in washdown applications.

Features and Benefits

- 303 Stainless Steel corrosion resistant shell will not rust or otherwise contaminate applications
- Self lubricating liner eliminates costly maintenance and labor
- Non-magnetic and corrosion resistant
- FDA, USDA and washdown compliant
- Special machining options available
- Available in Open and Closed types

Inch – FluoroNyliner Bushing Bearings

Maximum PV, continuous	10,000 psi ft/min
Maximum P, static	1,000 psi
Maximum V, no load	400 ft/min
Temperature Range	-400°F to 385°F / -240°C to 196°C
Shaft Finish, recommended	8-16 Ra
Coefficient of Friction	.12 - .20

FluoroNyliner LinearRace® Options

Food Grade FluoroNyliner Bushing bearings can be combined with a wide range of corrosion resistant LinearRace options, depending on the application requirements:

- **440C Stainless Steel** Corrosion resistant shafting with 50 HRC min case hardness
- **316 Stainless Steel** “Corrosion proof” shafting with no carbon content
- **Ultra Light Aluminum** Hard anodized coated, light weight aluminum shafting
- **Plated 60 Case Options** include Hard Chrome, Thin Dense Chrome, and Black Oxide

Pillow Block Options

Stainless steel pillow block assemblies are also available per request in Closed, Open and Flanged styles, all of which are available as single or twin styles.

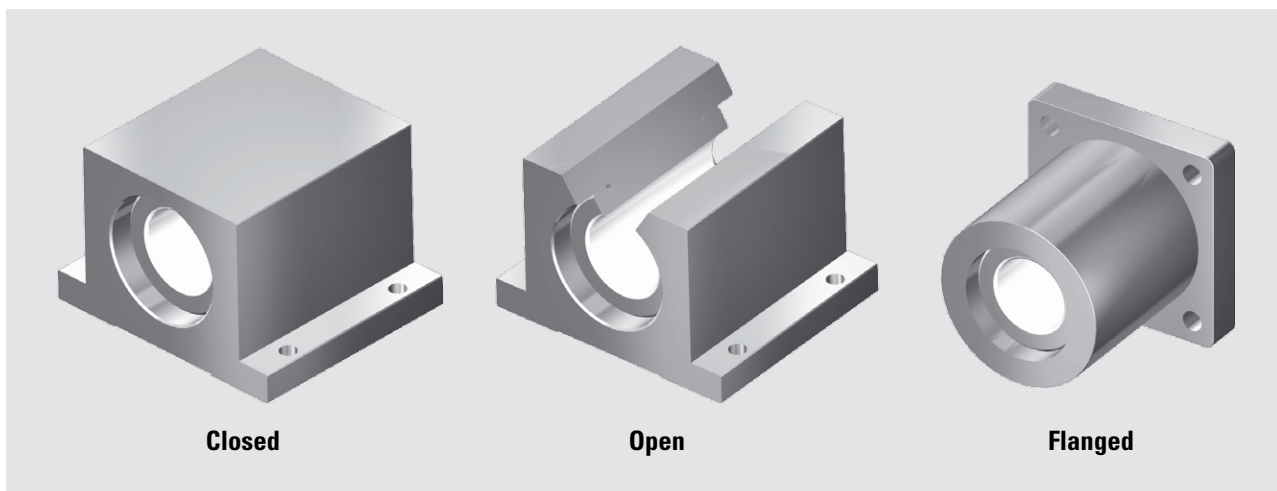

Inch – FluoroNyliner Bushing Bearings

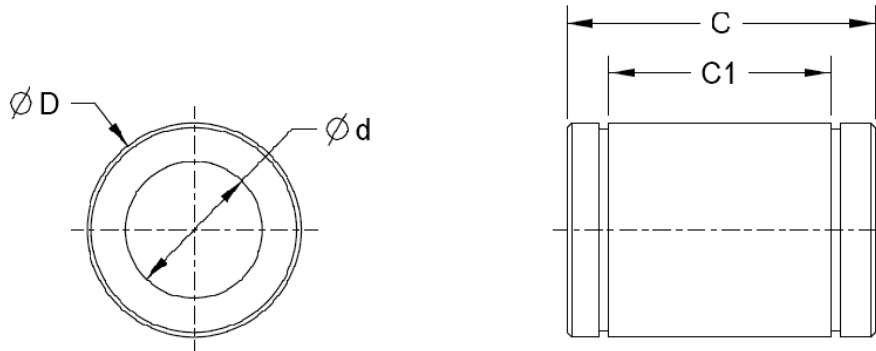

Closed Type

Part Number	Nominal Bearing Diameter	Working Bore Diameter (d)	Outside Diameter (D)	Length (C)	Distance Between Retaining Rings (C1)	Bearing Weight (lbs)
FNYBU06F	3/8	.3765/.3755	.6250/.6240	.875/.860	.562	.016
FNYBU08F	1/2	.5015/.5005	.8750/.8740	1.250/1.235	.875	.041
FNYBU10F	5/8	.6265/.6255	1.1250/1.1240	1.500/1.485	1.000	.091
FNYBU12F	3/4	.7518/.7508	1.2500/1.2490	1.625/1.610	1.062	.109
FNYBU16F	1	1.0018/1.0008	1.5625/1.5615	2.250/2.235	1.625	.228
FNYBU20F	1 1/4	1.2518/1.2508	2.0000/1.9990	2.625/2.605	1.875	.459
FNYBU24F	1 1/2	1.5018/1.5008	2.3750/2.3735	3.000/2.980	2.250	.750

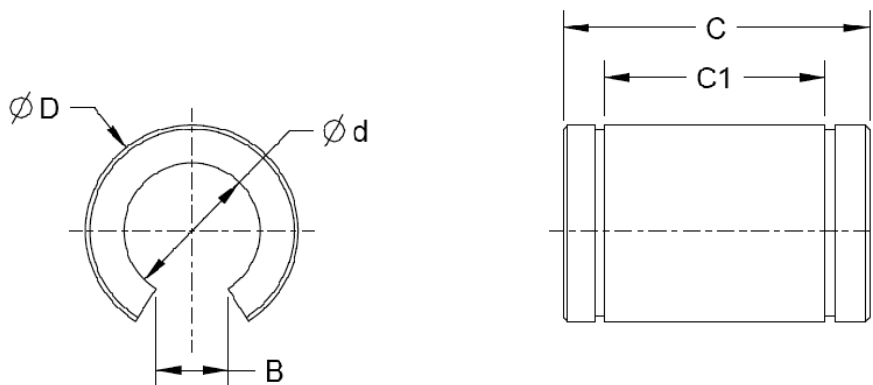

Open Type

Part Number	Nominal Bearing Diameter	Working Bore Diameter (d)	Outside Diameter (D)	Length (C)	Distance Between Retaining Rings (C1)	Slot Width Min (B)	Bearing Weight (lbs)
FNYBU06FOPN	3/8	.3765/.3755	.6250/.6240	.875/.860	.562	.156	.013
FNYBU08FOPN	1/2	.5015/.5005	.8750/.8740	1.250/1.235	.875	.312	.034
FNYBU10FOPN	5/8	.6265/.6255	1.1250/1.1240	1.500/1.485	1.000	.375	.072
FNYBU12FOPN	3/4	.7518/.7508	1.2500/1.2490	1.625/1.610	1.062	.438	.091
FNYBU16FOPN	1	1.0018/1.0008	1.5625/1.5615	2.250/2.235	1.625	.563	.184
FNYBU20FOPN	1 1/4	1.2518/1.2508	2.0000/1.9990	2.625/2.605	1.875	.625	.381
FNYBU24FOPN	1 1/2	1.5018/1.5008	2.3750/2.3735	3.000/2.980	2.250	.750	.630

Accessories



Described here are accessories for Linear Ball Bushing Bearings and pillow blocks including retaining rings, external seals, integral seals and resilient mounts.

Inch – Accessories

Lube for Life Mod Kits

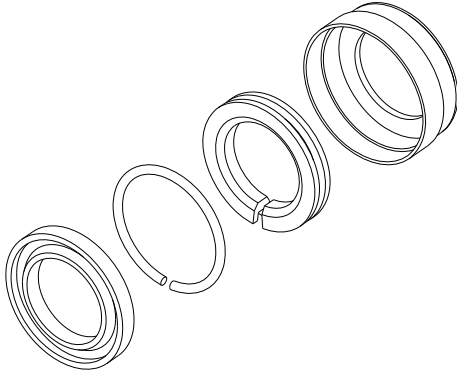

Lube for Life modification kits provide continuous bearing lubrication and enhanced protection for a broad range of applications. The Lube for Life attachments consist of a section of oil saturated polymer actively compressed by a contact spring, inside a standard Pillow Block seal. Mod Kits are for use with non self-lubricating Super and Super Smart Ball Bushing bearing Pillow Blocks. Each Mod Kit includes 2 Lube-for-Life cartridges and assembly instructions.

Closed Type Cartridges

Nominal LinearRace Diameter	Part Number	D1	D2	A	B
.500	MODKIT8-L4L	.94	.888	.45	.23
.750	MODKIT12-L4L	1.32	1.252	.46	.24
1.000	MODKIT16-L4L	1.63	1.565	.58	.30
1.250	MODKIT20-L4L	2.08	2.004	.78	.42
1.500	MODKIT24-L4L	2.46	2.379	.79	.43

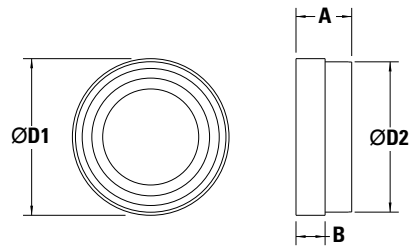

Open Type Cartridges

Nominal LinearRace Diameter	Part Number	D1	D2	A	B
.500	MODKIT80PN-L4L	.94	.888	.43	.31
.750	MODKIT120PN-L4L	1.32	1.252	.43	.30
1.000	MODKIT160PN-L4L	1.63	1.565	.49	.30
1.250	MODKIT200PN-L4L	2.08	2.004	.78	.42
1.500	MODKIT240PN-L4L	2.46	2.379	.79	.43

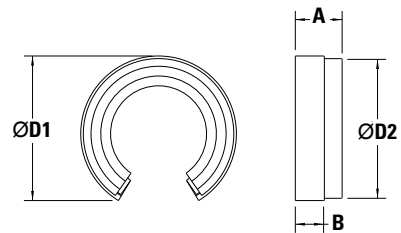

Retaining Rings

Internal Retaining Rings (Type PR)

Push-in retaining rings, as shown, are for use with Super Smart, Super and Precision Steel Ball Bushing closed type bearings. Each retaining ring is installed inside the housing bore at each end of the Ball Bushing bearing.

(Dimensions in inches)

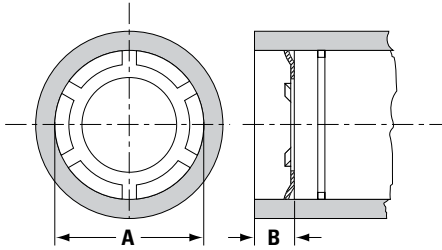

Part Number	Use with Ball Bushing bearing Part Number	Nominal Housing Bore A	Minimum End Space required B
PR250	SUPER4 or 4812 ⁽¹⁾	.500	.060
PR375	SUPER6 or 61014 ⁽¹⁾	.625	.060
PR500	SUPER8 or 81420 ⁽¹⁾	.875	.080
PR625	SSU10 or SUPER10 or 101824 ⁽¹⁾	1.125	.080
PR750	SSU12 or SUPER12 or 122026 ⁽¹⁾	1.250	.080
PR1000	SSU16 or SUPER16 or 162536 ⁽¹⁾	1.563	.080
PR1250	SSU20 or SUPER20 or 203242 ⁽¹⁾	2.000	.080
PR1500	SSU24 or SUPER24 or 243848 ⁽¹⁾	2.375	.100
PR2000	SUPER32 or 324864 ⁽¹⁾	3.000	.100

⁽¹⁾Applies to A and XA Type Precision Steel Ball Bushing Bearings

External Retaining Rings (Types C and W)

Type W: External retaining rings fit into the retaining ring grooves on the outside diameter of Super Smart, Super and Precision Steel Ball Bushing Bearings to provide external mounting retention. Available in standard and stainless steel versions.

Type C: External retaining rings fit into the retaining ring grooves on the outside diameter of Super Smart, Super and Precision Steel Ball Bushing Bearings (Open and Closed Type) to provide external mounting retention. Available in standard and stainless steel versions.

(Dimensions in inches)

External Retaining Rings (Type W)

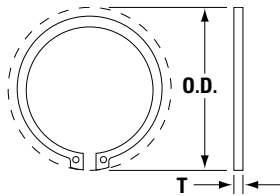

Standard Steel Part Number	Stainless Steel Part Number	Use with Ball Bushing bearing Part Number	T	O.D.
-	W125SS	INST258SS ⁽¹⁾	.025	.520
-	W187SS	INST369SS ⁽¹⁾	.025	.560
W250	W250SS	SUPER4 or 4812 ⁽¹⁾	.035	.720
C250	C250SS		.035	.550
W375	W375SS	SUPER6 or 61014 ⁽¹⁾	.035	.850
C375	C375SS		.035	.673
W500	W500SS	SUPER8 or 81420 ⁽¹⁾	.042	1.150
C500	C500SS		.042	.923
W625	W625SS	SSU10 or SUPER10 or 101824 ⁽¹⁾	.050	1.510
C625	C625SS		.050	1.180
W750	W750SS	SSU12 or SUPER12 or 122026 ⁽¹⁾	.050	1.620
C750	C750SS		.050	1.301
W1000	W1000SS	SSU16 or SUPER16 or 162536 ⁽¹⁾	.062	2.040
C1000	C1000SS		.062	1.620
W1250	-	SSU20 or SUPER20 or 203242 ⁽¹⁾	.062	2.500
C1250	-		.062	2.040
W1500	-	SSU24 or SUPER24 or 243848 ⁽¹⁾	.078	2.910
C1500	-		.078	2.429
W2000	-	SUPER32 or 324864 ⁽¹⁾	.093	3.600
W2500	-	406080 ⁽¹⁾	.109	4.420
W3000	-	487296 ⁽¹⁾	.109	5.310
W4000	-	6496128 ⁽¹⁾	.125	7.100

⁽¹⁾Applies to A, XA and OPN Type Precision Steel Ball Bushing Bearings

External Retaining Rings (Type C)

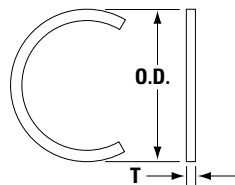

Inch – Accessories

External Seals

Seals for Fixed Diameter Housings

Double acting seals for Super Smart, Super and Precision Steel closed type Ball Bushing Bearings. Standard and stainless versions. Sizes 1 1/2 inch and above use spring fingers to reinforce sealing capability which could add to seal drag.

(Dimensions in inches)

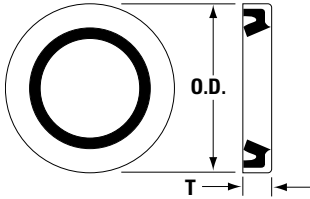

Standard Steel Seal Part Number	Stainless Steel Seal Part Number	Use with Ball Bushing Bearing Part Number	Nominal Linear Race Diameter	T	O.D.
S250	S250SS	SUPER4 or 4812 ⁽¹⁾	.250	.125	.504
S375	S375SS	SUPER6 or 61014 ⁽¹⁾	.375	.125	.629
S500	S500SS	SUPER8 or 81420 ⁽¹⁾	.500	.125	.879
S625	S625SS	SSU10 or SUPER10 or 101824 ⁽¹⁾	.625	.125	1.129
S750	S750SS	SSU12 or SUPER12 or 122026 ⁽¹⁾	.750	.125	1.254
S1000	S1000SS	SSU16 or SUPER16 or 162536 ⁽¹⁾	1.000	.187	1.567
S1250	-	SSU20 or SUPER20 or 203242 ⁽¹⁾	1.250	.375	2.004
S1500	-	SSU24 or SUPER24 or 243848 ⁽¹⁾	1.500	.375	2.379
S2000	-	SUPER32 or 324864 ⁽¹⁾	2.000	.375	3.004
S2500	-	406080 ⁽¹⁾	2.500	.375	3.756
S3000	-	487296 ⁽¹⁾	3.000	.500	4.506
S4000	-	6496128 ⁽¹⁾	4.000	.500	6.006

⁽¹⁾Applies to Aand XA Precision Steel Ball Bushing Bearings

Seals for Adjustable Housing

Double acting seals for Super Smart, Super and Precision Steel Ball Bushing Bearings. Seals have a radial slot through the circumferences to facilitate diameter adjustment. Standard and stainless steel versions.

(Dimensions in inches)

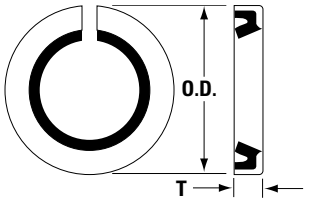

⁽²⁾Applies to ADJ Type Precision Steel Ball Bushing Bearings

Standard Steel Seal Part Number	Stainless Steel Seal Part Number	Use with Adjustable Type Ball Bushing Bearing Part Number	Nominal Linear Race Diameter	T	O.D.
ADJS500	ADJS500SS	SUPER8 or 81420 ⁽²⁾	.500	.125	.879
ADJS625	ADJS625SS	SSU10 or SUPER10 or 101824 ⁽²⁾	.625	.125	1.129
ADJS750	ADJS750SS	SSU12 or SUPER12 or 122026 ⁽²⁾	.750	.125	1.254
ADJS1000	ADJS1000SS	SSU16 or SUPER16 or 162536 ⁽²⁾	1.000	.187	1.567
ADJS1250	-	SSU20 or SUPER20 or 203242 ⁽²⁾	1.250	.375	2.004
ADJS1500	-	SSU24 or SUPER24 or 243848 ⁽²⁾	1.500	.375	2.379
ADJS2000	-	SUPER32 or 324864 ⁽²⁾	2.000	.375	3.004
ADJS2500	-	406080 ⁽²⁾	2.500	.375	3.756
ADJS3000	-	487296 ⁽²⁾	3.000	.500	4.506
ADJS4000	-	6496128 ⁽²⁾	4.000	.500	6.006

⁽²⁾Applies to ADJ type Precision Steel Ball Bushing Bearings

Seals for Open Type Housing

Double acting seals for Super Smart, Super and Precision Steel Ball Bushing Open Type bearings. Standard and stainless steel versions.

(Dimensions in inches)

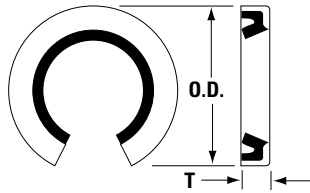

⁽³⁾Applies to OPN Type Precision Steel Ball Bushing Bearings

Standard Steel Seal Part Number	Stainless Steel Seal Part number	Use with Adjustable Type Ball Bushing Bearing Part Number	Nominal Linear Race Diameter	T	O.D.
OPNS500	OPNS500SS	SUPER-8 or 81420 ⁽³⁾	.500	.125	.879
OPNS625	OPNS625SS	SSU10 or SUPER10 or 101824 ⁽³⁾	.625	.125	1.129
OPNS750	OPNS750SS	SSU12 or SUPER12 or 122026 ⁽³⁾	.750	.125	1.254
OPNS1000	OPNS1000SS	SSU16 or SUPER16 or 162536 ⁽³⁾	1.000	.187	1.567
OPNS1250	-	SSU20 or SUPER20 or 203242 ⁽³⁾	1.250	.375	2.004
OPNS1500	-	SSU24 or SUPER24 or 243848 ⁽³⁾	1.500	.375	2.379
OPNS2000	-	SUPER32 or 324864 ⁽³⁾	2.000	.375	3.004
OPNS2500	-	406080 ⁽³⁾	2.500	.375	3.756
OPNS3000	-	487296 ⁽³⁾	3.000	.500	4.506
OPNS4000	-	6496128 ⁽³⁾	4.000	.500	6.006

⁽³⁾Applies to OPN type Precision Steel Ball Bushing Bearings

Integral Seals

Seals for Sealed Super Ball Bushing Bearings (Closed Type)

Double acting replacement seals for the Sealed Super Ball Bushing* bearing.

(Dimensions in inches)

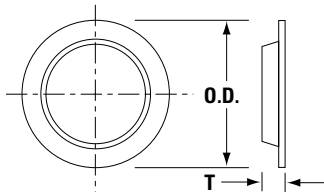

Part number	Use with Super Ball Bushing Bearing Number	Nominal LinearRace Diameter	T	O.D.
S500DD	SUPER8DD	.500	.120	.770
S625DD	SUPER10DD	.625	.120	1.010
S750DD	SUPER12DD	.750	.120	1.110
S1000DD	SUPER16DD	1.000	.180	1.390

Seals for Sealed Super Ball Bushing Bearings (Open Type)

Double acting replacement seals for the Sealed Super Ball Bushing bearing.

(Dimensions in inches)

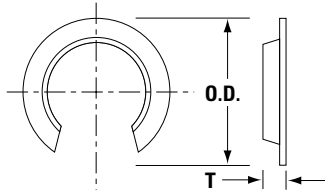

Part Number	Use with Super Ball Bushing Bearing Number	Nominal LinearRace Diameter	T	O.D.
S500PNDD	SUPER8DDOPN	.500	.120	.770
S625PNDD	SUPER10DDOPN	.625	.120	1.010
S750PNDD	SUPER12DDOPN	.750	.120	1.110
S1000PNDD	SUPER16DDOPN	1.000	.180	1.390

Felt Seals for Closed Type Ball Bushing Bearings

Felt seals for Super Smart, Super and Precision Steel closed type Ball Bushing Bearings. Felt seals reduce drag for applications where reduced friction is critical. Felt seals provide minimal protection from the ingress of contamination. Use PR type external retaining rings for retention.

(Dimensions in inches)

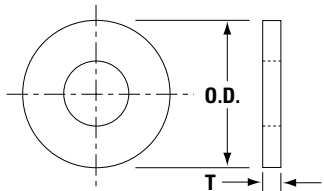

⁽¹⁾Applies to A, XA and ADJ Type Precision Steel Ball Bushing Bearings

Standard Felt Seal Part Number	Use with Ball Bushing Bearing Part Number	Nominal LinearRace Diameter	T	O.D.
FS250	SUPER4 or 4812 ⁽¹⁾	.250	.125	.500
FS375	SUPER6 or 61014 ⁽¹⁾	.375	.125	.625
FS500	SUPER8 or 81420 ⁽¹⁾	.500	.125	.875
FS625	SSU10 or SUPER10 or 101824 ⁽¹⁾	.625	.125	1.125
FS750	SSU12 or SUPER12 or 122026 ⁽¹⁾	.750	.125	1.250
FS1000	SSU16 or SUPER16 or 162536 ⁽¹⁾	1.000	.125	1.563
FS1250	SSU20 or SUPER20 or 203242 ⁽¹⁾	1.250	.188	2.000
FS1500	SSU24 or SUPER24 or 243848 ⁽¹⁾	1.500	.188	2.375
FS2000	SUPER32 or 324864 ⁽¹⁾	2.000	.188	3.000

⁽¹⁾Applies to A, XA and ADJ type Precision Steel Ball Bushing Bearings

Seals for Roundway Linear Roller Bearings

Standard seals for both single and dual types.

(Dimensions in inches)

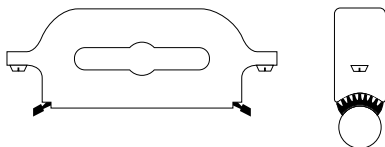

Seal Number	Nominal LinearRace Diameter	Overall Length L	Overall Width W	Overall Height from Centerline of LinearRace H
RS16	1.000	5.00	1.00	2.25
RS24	1.500	6.50	1.38	3.25
RS32	2.000	8.50	1.88	4.25
RS48	3.000	13.00	2.63	6.50
RS64	4.000	17.00	3.38	8.50

Inch – Accessories

Resilient Mounts

Resilient Ball Bushing Bearing Mounts for Ease of Installation

Used with Precision Steel Ball Bushing Bearings Type A and XA. Resilient Ball Bushing bearing mounts are sometimes used when absolute rigidity is not essential and where a slightly larger housing bore can be accommodated. The self-aligning feature of these mounts guarantee uniform load distribution over the entire length of the load carrying balls and compensates for slight errors in housing bores and parallel 60 Case LinearRace alignment. The mount consists of a band of resilient material that can be easily mounted to the outside diameter of the Ball Bushing bearing. After it is installed in the housing bore it provides permanent resilient, self-aligning support for the bearing. Resilient mounts consist of one rubber ring, 2 spacers and 2 retaining rings. Ball Bushing Bearings must be purchased separately.

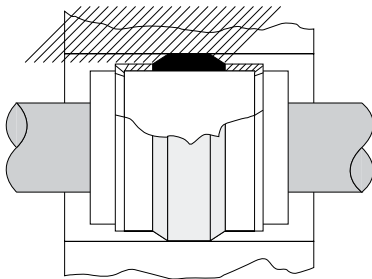

(Dimensions in inches)

Resilient Mount Assembly Part Number	Use with Ball Bushing Bearing Number	Nominal LinearRace Diameter	Recommended Housing Bore ±.005
RSL250	A or XA-4812	.250	.625
RSL375	A or XA-61014	.375	.750
RSL500	A or XA-81420	.500	1.000
RSL625	A or XA-101824	.625	1.313
RSL750	A or XA-122026	.750	1.438
RSL1000	A or XA-162536	1.000	1.813
RSL1250	A or XA-203242	1.250	2.313
RSL1500	A or XA-243848	1.500	2.750

Metric - General Product Overview

Thomson Linear Motion Metric Components

The RoundRail Advantage - The inherent ability of a RoundRail Ball Bushing bearing system to absorb torsional misalignment caused by inaccuracies in carriage or base machining or machine deflection...with little increase in stress to bearing components.

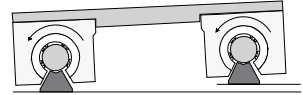

Super Smart Ball Bushing Bearings

Thomson Super Smart Ball Bushing Bearings represent a major advancement for Linear bearing technology, worldwide.

This patented self-aligning linear bearing provides two times the load carrying capacity of the industry standard Thomson Super Ball Bushing bearing. Super Smart Ball Bushing Bearings also provide eight times the bearing life and up to five times the LinearRace shaft life when used in place of standard Super type bearings. (See page 127)



Super Smart Ball Bushing Pillow Blocks

Thomson Super Smart Ball Bushing Pillow Blocks available in closed, adjustable and open styles in both single and twin versions.

To minimize installation time and cost, the Super Smart Ball bushing bearing can be ordered factory-installed in an industry standard single or twin pillow block. The closed type pillow block is used in end supported applications for spanning or bridging a gap. The open style is used in continuously supported applications when maximum rigidity and stiffness is required. Each Super Smart Pillow Block is complete with integral double acting seals which keep out contaminants, retain lubrication and maximize bearing life. Since each pillow block is dimensionally interchangeable with industry standard pillow blocks, system performance improvements can be realized immediately. All pillow blocks are available and in stock from 1800 authorized distributors worldwide. (See page 136)



MultiTrac Ball Bushing Bearings

Rigid, high load capacity, linear bearings

Extremely rigid MultiTrac Ball Bushing Bearing gives you less deflection and twice the load capacity or eight times the travel life of conventional Ball Bushing bearings. This increased bearing performance significantly reduces downtime and maintenance, while increasing machine reliability. The improvement in bearing capacity permits designers to optimize system compactness and minimizes hardware costs. The bearing's patented ball control technology eliminates binding and chatter (stick-slip) common to high friction, plain bushings. Available and stocked in 7 standard sizes from over 1800 distributor locations worldwide. (See page 148)



NEW: Super Ball Bushing Bearings and Pillow Blocks

High performance from superior design:

A coefficient of friction as low as 0,001. This allows the use of smaller less expensive motors, belts, gears and ball screws, when replacing high friction, plain bearings. A self-aligning capability up to 0,5° compensates for inaccuracies in base flatness or carriage machining. Achieved with Thomson Super Bearing plates which have defined radius crowns for maximized self-alignment accuracy. Accelerations as high as 150m/s² and steady state travel speeds up to 3 m/s without the derating factors commonly required with linear guides. Quick to ship, drop-in replacement parts for existing applications. Twin version with two Super Ball Bushing bearings providing twice the load capacity or 8 times more travel life than the single version. (See page 156)

Application

Thomson products are engineered to world-class performance standards, so that you can specify them with confidence worldwide. This Engineering Support section provides charts, formulas and technical information for:

- Ball Bushing bearing selection
- Load considerations for horizontal, side and vertical mounted applications
- Shaft deflection
- Installation
- Tolerance zones for internal and external diameters

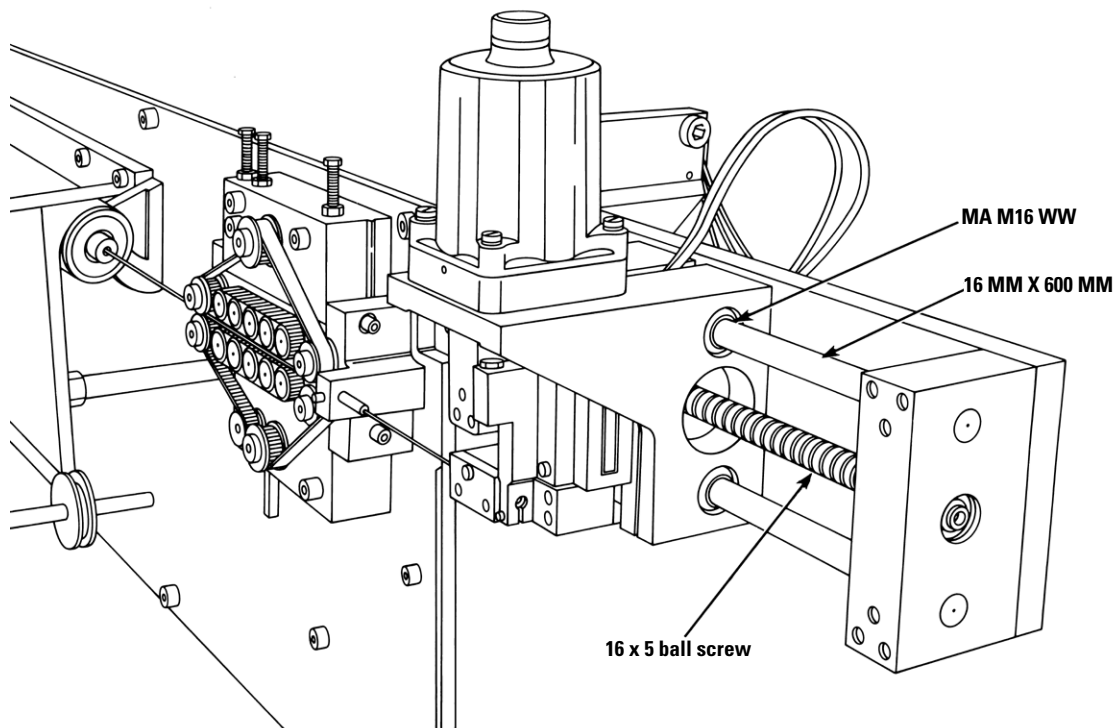

Metric – Super Smart Ball Bushing Bearings

Super Smart Ball Bushing Bearings



Metric Ball Bearing Bushing

Thomson Super Smart Ball Bushing Bearing products offer:

- Up to six times the load capacity or 216 times the travel life of conventional linear bearings.
- Twice the load capacity or eight times the travel life of industry standard Thomson Super Ball Bushing Bearings.
- Universal self-alignment feature, that compensates for misalignment of housing bores and 60 Case LinearRace shaft deflection, optimizes load distribution between ball tracks and assures uniform ball loading over the entire length of the bearing plate. Installation time and cost is minimized while bearing performance and life is maximized.
- Technologically advanced design that allows the bearing to maintain its diametral fit-up when installed in a housing that is slightly out-of-round.
- Up to 400% longer LinearRace shaft life and minimal machine downtime when replacing conventional linear bearings or the standard Super Ball Bushing Bearing.
- RoundRail Advantage combined with universal self-alignment eliminating the need for derating factors commonly required when using linear guides.
- Coefficient of friction as low as 0,001. This allows the use of smaller less expensive motors, belts, gears and ball screws, when replacing high friction, plain bearings.
- Closed and open configurations.
- Double lip integral wipers that keep out dirt while retaining lubrication. Travel life is maximized.
- Worldwide availability from over 1800 authorized distributors.

Available in both European and JIS standard dimensions.

Metric – Super Smart Ball Bushing Bearings

Part Number Description and Specification

Super Smart Ball Bushing Bearings (Closed Type) for End Supported Applications

SSEM160PNWW-CR

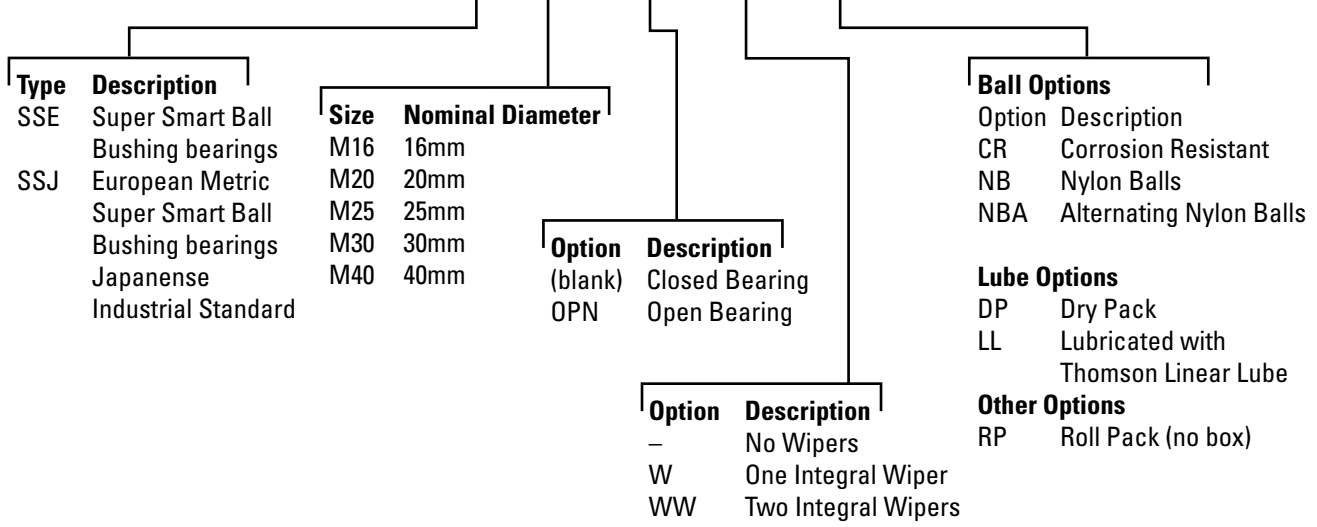

For addition informaiton on bearing options see page 273.

Metric – Super Smart Ball Bushing Bearings

The Super Smart Advantage

Advantage: Load Capacity

The Super Smart Ball Bushing Bearing provides twice the load capacity of the industry standard Thomson Super Ball Bushing Bearing and six times the load capacity of conventional linear bearings.

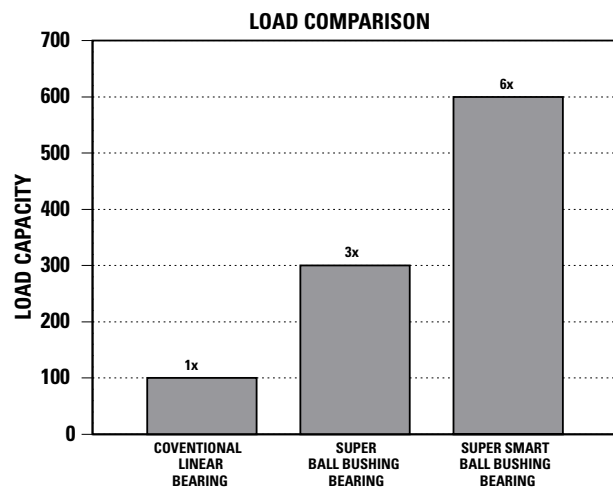

Downsizing

The photograph above shows a conventional Ball Bushing bearing, Super Ball Bushing Bearing and Super Smart Ball Bushing Bearing, all of which have the same load capacity.

Advantage: Travel Life

The Super Smart Ball Bushing Bearing provides eight times the travel life of the industry standard Thomson Super Ball Bushing Bearing and 216 times the travel life of conventional linear bearings.

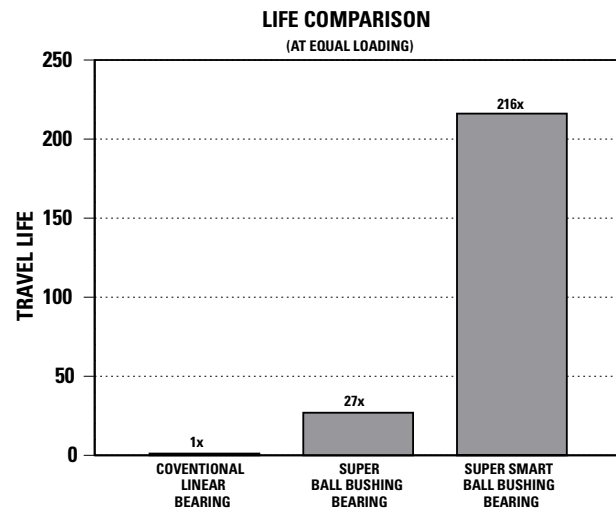

Metric – Super Smart Ball Bushing Bearings

Super Smart Ball Bushing Bearings (Closed Type)

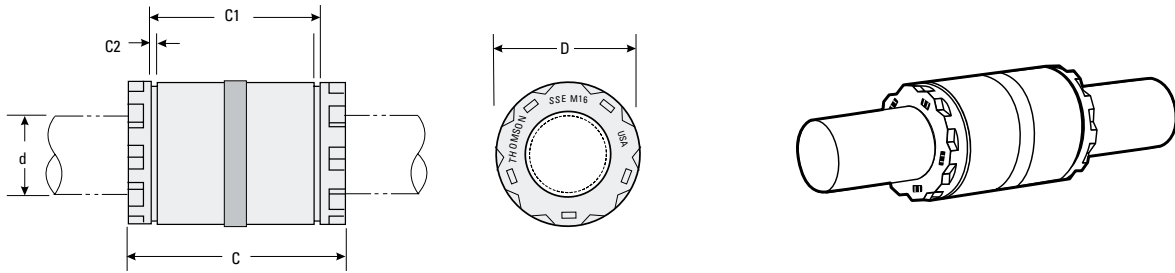

Super Smart Ball Bushing Bearings (Closed Type) (Dimensions in mm)

Part Number			d ⁽⁴⁾	D	C h14	C1 H13	C2 min.	Number of Ball Tracks	Mass (kg)	Dynamic Load W ⁽¹⁾⁽³⁾ (N)	Load Limit W ₀ ⁽²⁾⁽³⁾ (N)
Without Integral Wipers	With one Integral Wiper	With two Integral Wipers									
SSE M16	SSE M16 W	SSE M16 WW	16	26	36	24,6	1,30	10	0,030	2200	2400
SSE M20	SSE M20 W	SSE M20 WW	20	32	45	31,2	1,60	10	0,066	4000	4400
SSE M25	SSE M25 W	SSE M25 WW	25	40	58	43,7	1,85	10	0,135	6700	7300
SSE M30	SSE M30 W	SSE M30 WW	30	47	68	51,7	1,85	10	0,206	8300	9100
SSE M40	SSE M40 W	SSE M40 WW	40	62	80	60,3	2,15	10	0,392	13700	15000

(1) For rated travel life of 100 km. For longer travel lives, reduce load to $\bullet(100/L)^{0,33}$ where L (km) is the required travel life. Do not exceed the Dynamic Load Rating for travel life of less than 100 km.

(2) The Load Limit is the maximum load that may be applied to a bearing/shaft. It is important to analyze the application so that peak and/or shock do not exceed the Load Limit.

(3) The load capacities W and W_q are valid for a resultant load applied at 90° with the ball tracks oriented as shown in the polar graphs below. If the resultant acts along another direction, the appropriate multiplicative correction factor K_q should be applied to W and W_q respectively. Open type bearings have reduced load capacities when used in pull-off situations.

(4) Internal bearing diameter is affected by the housing bore, see Table 1.

(5) Hole for anti-rotation pin is below centerline.

NOTE: External seals and retaining rings are available. See page 167 for specifications.

NOTE: For additional technical information, see the Engineering section beginning on page 262.

NOTE: For a corrosion resistant bearing add suffix-cr to the part number and reduce the load capacity by 30%.

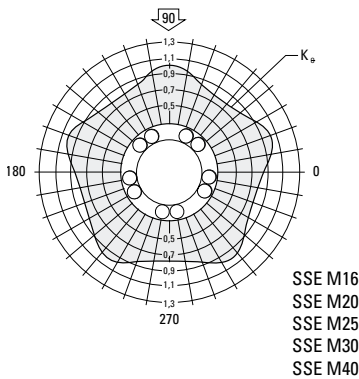

Metric – Super Smart Ball Bushing Bearings

Super Smart Ball Bushing Bearings (Open Type)

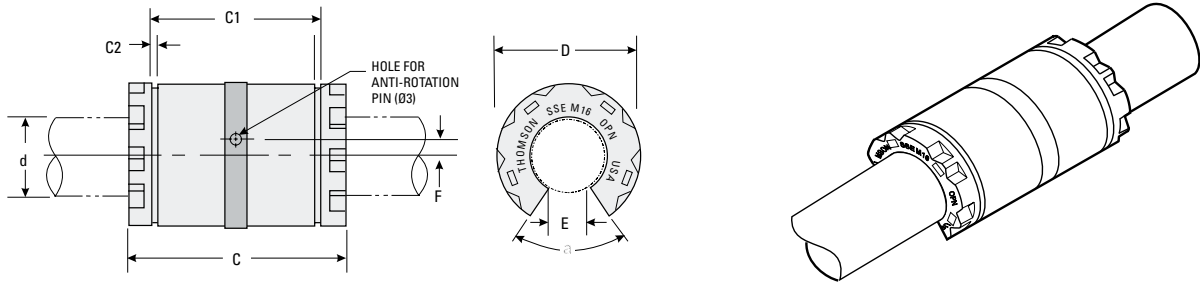

Super Smart Ball Bushing Bearings (Open Type) (Dimensions in mm)

Part Number			d ⁽⁴⁾	D	C h14	C1 H13	C2 min.	E	F	Angle α (deg)	Number of Ball Tracks	Mass (kg)	Dynamic Load W ⁽¹⁾⁽³⁾ (N)	Load Limit W ₀ ⁽²⁾⁽³⁾ (N)
Without Integral Wipers	With one Integral Wiper	With two Integral Wipers												
SSE M16 OPN	SSE M16 OPN W	SSE M16 OPN WW	16	26	36	24,6	1,30	9,0	0	70	8	0,023	2200	2400
SSE M20 OPN	SSE M20 OPN W	SSE M20 OPN WW	20	32	45	31,2	1,60	10,0	0	50	8	0,054	4000	4400
SSE M25 OPN	SSE M25 OPN W	SSE M25 OPN WW	25	40	58	43,7	1,85	12,5	1,50 ⁽⁵⁾	60	8	0,107	6700	7300
SSE M30 OPN	SSE M30 OPN W	SSE M30 OPN WW	30	47	68	51,7	1,85	13,7	2,00	55	8	0,163	8300	9100
SSE M40 OPN	SSE M40 OPN W	SSE M40 OPN WW	40	62	80	60,3	2,15	19,0	1,50	54	8	0,315	13700	15000

- (1) For rated travel life of 100 km. For longer travel lives, reduce load to $\bullet(100/L)^{0,33}$ where L (km) is the required travel life. Do not exceed the Dynamic Load Rating for travel life of less than 100 km.
 - (2) The Load Limit is the maximum load that may be applied to a bearing/shaft. It is important to analyze the application so that peak and/or shock do not exceed the Load Limit.
 - (3) The load capacities W and Wq are valid for a resultant load applied at 90° with the ball tracks oriented as shown in the polar graphs below. If the resultant acts along another direction, the appropriate multiplicative correction factor Kq, should be applied to W and Wq respectively. Open type bearings have reduced load capacities when used in pull-off situations.
 - (4) Internal bearing diameter is affected by the housing bore, see Table 1.
 - (5) Hole for anti-rotation pin is below centerline.
- NOTE: External seals and retaining are available. See page 167 for specifications.
 NOTE: For additional technical information, see the Engineering section beginning on page 262.

Table 1 - Standard Diametral Clearances

Nominal Shaft Diameter d (mm)	Nominal Housing Bore Diameter d (mm)	Diametral Clearance	
		Housing Bore H7 (µm)	Housing Bore H6 (µm)
16	26	+33 +4	+26 +3
20	32	+37 +6	+30 +4
25	40	+37 +6	+30 +4
30	47	+37 +6	+30 +4
40	62	+44 +7	+35 +5

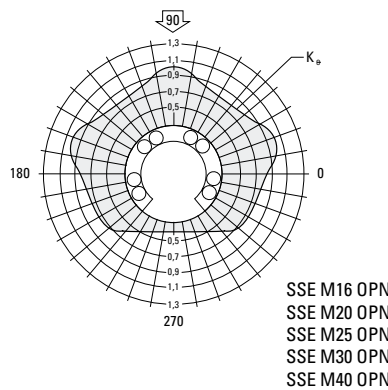

For Super Smart Ball Bushing Bearings mounted in a housing and with LinearRace shafts, h6 tolerance

Metric – Super Smart Ball Bushing Bearings

Super Smart Ball Bushing Bearings - JIS Specifications (Closed Type)

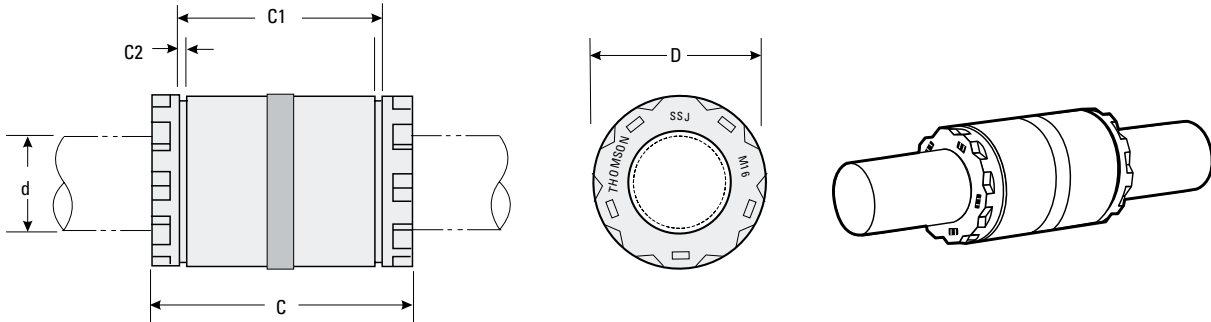

Designed to be used for new or existing JIS (Japanese Industrial Standard) designs

Part Number			Dimensions (mm)					Number of Ball Tracks	Mass (kg)	Dynamic Load $W^{(1)(3)}$ (N)	Load Limit $W_0^{(2)(3)}$ (N)
Without Integral Wipers	With One Integral Wiper	With Two Integral Wiper	Nominal LinearRace Dia. d	C h14	C1 h13	C2 min.	Nominal Housing Bore Dia. $D^{(2)}$				
SSJM 16	SSJM 16 W	SSJM 16 WW	16	37	26.5	1.60	28	10	.030	2200	2400
SSJM 20	SSJM 20 W	SSJM 20 WW	20	42	30.5	1.60	32	10	.066	4000	4400
SSJM 25	SSJM 25 W	SSJM 25 WW	25	59	41	1.85	40	10	.133	6700	7300
SSJM 30	SSJM 30 W	SSJM 30 WW	30	64	44.5	1.85	45	10	.202	8300	9100
SSJM 40	SSJM 40 W	SSJM 40 WW	40	80	60.5	2.10	60	10	.392	13700	15000

(1) For rated travel life of 100 km. For longer travel lives, reduce load to $\bullet(100/L)^{0.33}$ where L (km) is the required travel life. Do not exceed the Dynamic Load Rating for travel life of less than 100 km.

(2) The Load Limit is the maximum load that may be applied to a bearing/shaft. It is important to analyze the application so that peak and/or shock do not exceed the Load Limit.

(3) The load capacities W and W_q are valid for a resultant load applied at 90° with the ball tracks oriented as shown in the polar graphs below. If the resultant acts along another direction, the appropriate multiplicative correction factor K_q , should be applied to W and W_q respectively. Open type bearings have reduced load capacities when used in pull-off situations.

(4) Refer to Table 1 to find the diametral tolerance between the LinearRace and Super Smart Ball Bushing bearing for bearing installation in housing H7 or J7 tolerance.

NOTE: External seals and retaining rings are available. See page 167 for specifications.

NOTE: For additional technical information, see engineering section beginning on page 262.

NOTE: For corrosion resistant bearing add suffix -cr to the part number and reduce the load capacity by 30%.

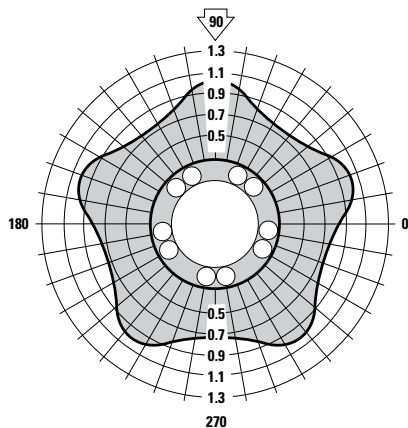

SSJ M16
SSJ M20
SSJ M25
SSJ M30
SSJ M40

Metric – Super Smart Ball Bushing Bearings

Super Smart Ball Bushing Bearings - JIS Specifications (Open Type)

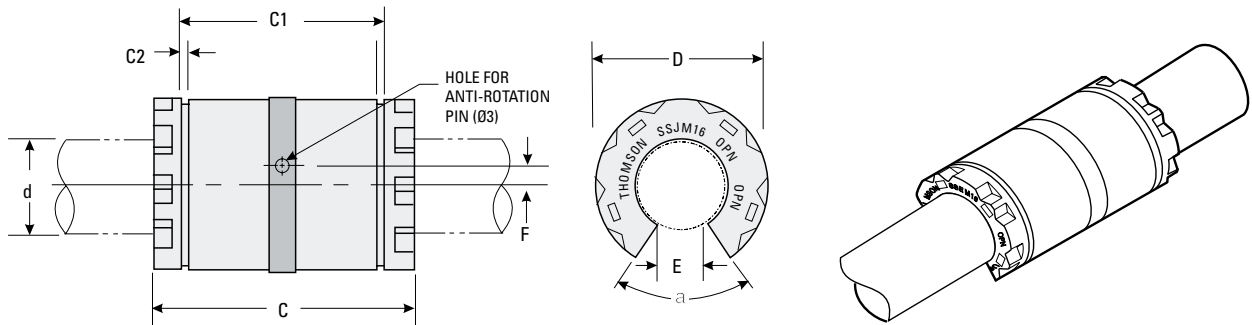

Designed to be used for new or existing JIS (Japanese Industrial Standard) designs

Part Number			Dimensions (mm)					Nominal Housing Bore Dia. D ⁽²⁾	E min.	a (deg)	Number of Ball Tracks	Mass (kg)	Dynamic Load W ⁽¹⁾⁽³⁾ (N)	Load Limit W ₀ ⁽²⁾⁽³⁾ (N)
Without Integral Wipers	With One Integral Wiper	With Two Integral Wiper	Nominal LinearRace Dia. d	C h14	C1 h13	C2 min.								
SSJM 16 OPN	SSJM 16 OPN W	SSJM 16 OPN WW	16	37	26.5	1.60	28	11	80	8	.023	2200	2400	
SSJM 20 OPN	SSJM 20 OPN W	SSJM 20 OPN WW	20	42	30.5	1.60	32	11	60	8	.054	4000	4400	
SSJM 25 OPN	SSJM 25 OPN W	SSJM 25 OPN WW	25	59	41	1.85	40	12	50	8	.107	6700	7300	
SSJM 30 OPN	SSJM 30 OPN W	SSJM 30 OPN WW	30	64	44.5	1.85	45	15	50	8	.163	8300	9100	
SSJM 40 OPN	SSJM 40 OPN W	SSJM 40 OPN WW	40	80	60.5	2.10	60	20	50	8	.315	13700	15000	

- (1) For rated travel life of 100 km. For longer travel lives, reduce load to $\bullet(100/L)^{0.33}$ where L (km) is the required travel life. Do not exceed the Dynamic Load Rating for travel life of less than 100 km.
- (2) The Load Limit is the maximum load that may be applied to a bearing/shaft. It is important to analyze the application so that peak and/or shock do not exceed the Load Limit.
- (3) The load capacities W and Wq are valid for a resultant load applied at 90° with the ball tracks oriented as shown in the polar graphs below. If the resultant acts along another direction, the appropriate multiplicative correction factor Kq, should be applied to W and Wq respectively. Open type bearings have reduced load capacities when used in pull-off situations.
- (4) Refer to Table 1 to find the diametral tolerance between the LinearRace and Super Smart Ball Bushing bearing for bearing installation in housing having either a H7 or J7 tolerance.

NOTE: External seals and retaining are available. See page 167 for specifications.

NOTE: For additional technical information, see engineering section beginning on page 262.

NOTE: For corrosion resistant bearing add suffix -cr to the part number and reduce the load capacity by 30%.

Table 1 – Standard Dimensional Clearances

Nominal LinearRace Dia. d (mm)	Nominal Housing Bore Diameter d (mm)	Dimensional Clearance	
		Housing Bore H7 (µm)	Housing Bore J7 (µm)
16	28	+33 +8	+24 -1
20	32	+39 +9	+28 -2
25	40	+39 +9	+28 -2
30	45	+39 +9	+28 -2
40	60	+44 +11	+35 -1

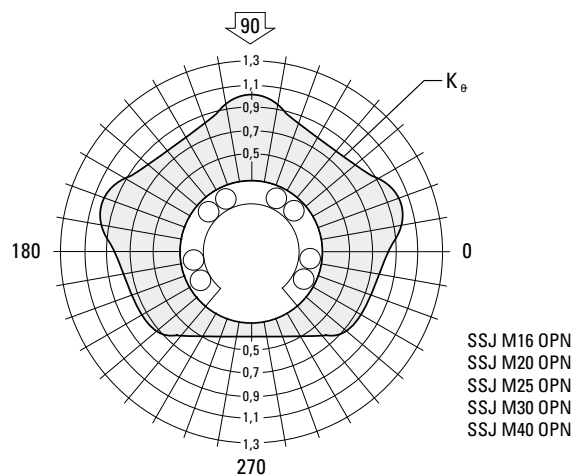

For Super Smart Ball Bushing Bearings mounted in a housing and with LinearRace shafts, h6 tolerances

Metric – Super Smart Ball Bushing Bearings

Application

Cam-Actuated Part Transfer Mechanism for Multiple-Transfer Press

Objective

Improve production rate and increase the service life of a transfer table mechanism.

Solution

Replace the conventional linear bearings with adjustable Super Smart twin pillow blocks.

Products Specified

- 2 - SSE TWNA M20 DD (Super Smart Twin Pillow Blocks)
- 4 - ASB M20 (Shaft support blocks) Blocks
- 2 - 20 MM X 600 mm 60 Case LinearRace Shaft

Benefits

The table achieved maximum cycle efficiency by reducing costly downtime and improving service life. Bearing life is increased from 1 to 8 years.

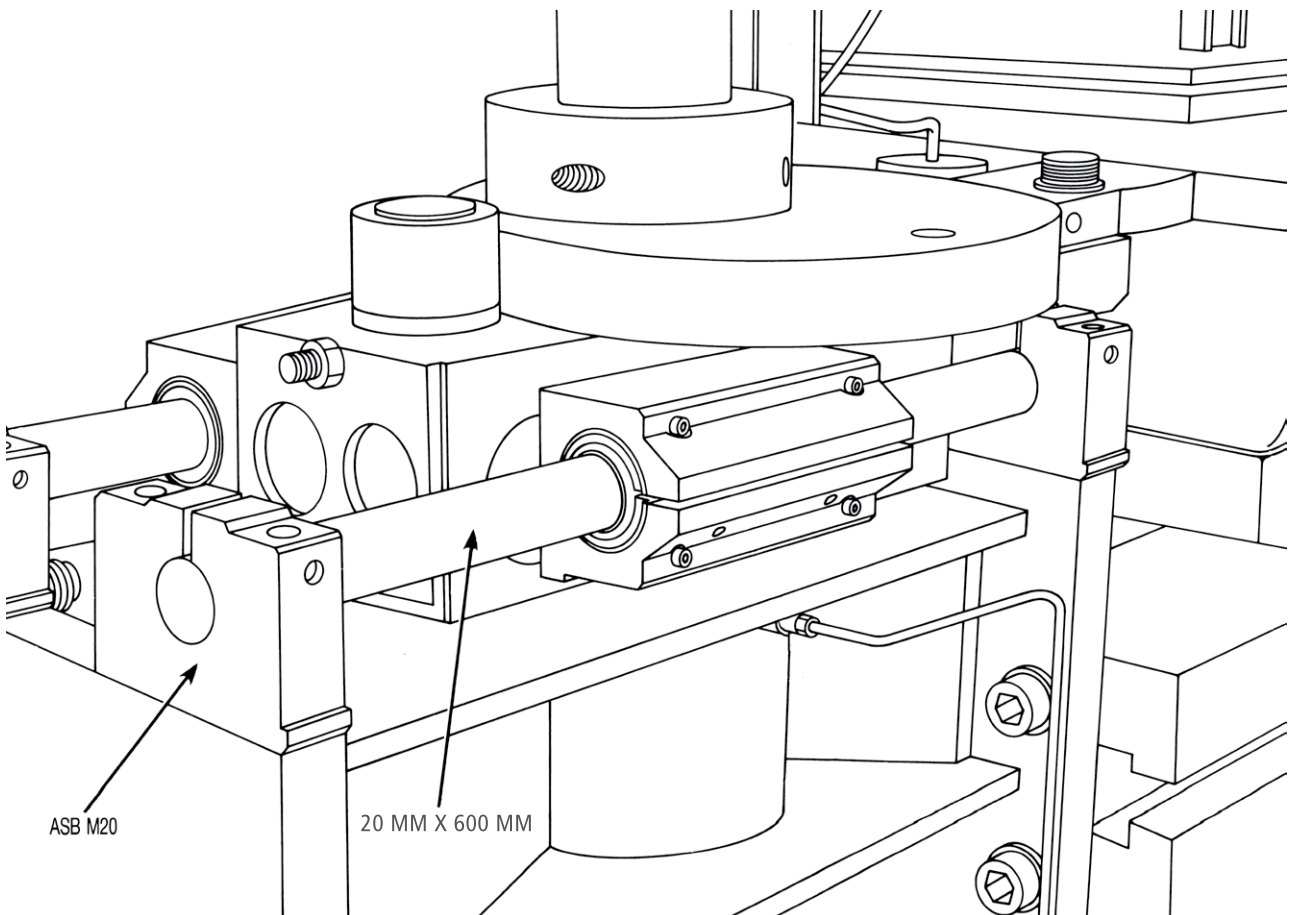

Metric – Super Smart Ball Bushing Bearings

X-Y Inspection System

Objective

Accurately position an inspection probe of an X-Y system over small electronic components.

Solution

Design an X-Y system with Super Smart Ball Bushing pillow blocks to provide accurate and repeatable movement of the test probe. Utilize Thomson Industries linear motion systems on the Y-axis to reduce cost and installation time.

Benefits

Outstanding positioning accuracy and repeatability was provided by the adjustable pillow blocks and ball screws. The use of a pre-engineered, pre-assembled linear motion system on the Y-axis saved valuable design and assembly time.

Products Specified

X-axis

- 2 - SSE TWNA M16 DD (Super Smart Twin pillow blocks)
- 4 - ASB M16 (Shaft support blocks)
- 2 - 16 MM X 600 MM (60 Case LinearRace shaft)
- 2 - 12 x5 Thomson ball screw assemblies

Y-axis

- 1 - 2CA M12 (pre-assembled linear motion system)
- 1 - 12 x5 Thomson ball screw assembly

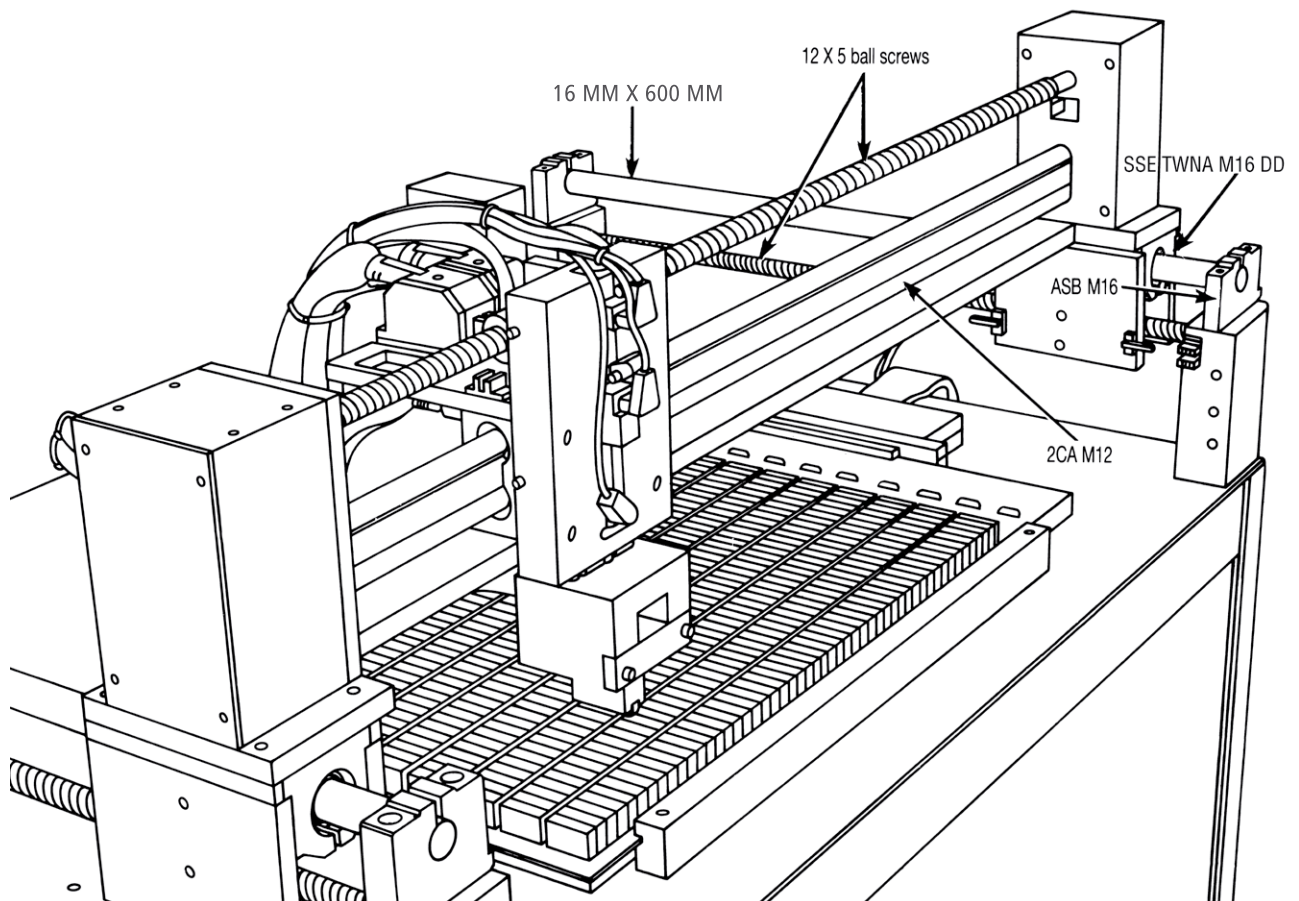

Metric – Super Smart Pillow Blocks

Super Smart Pillow Blocks

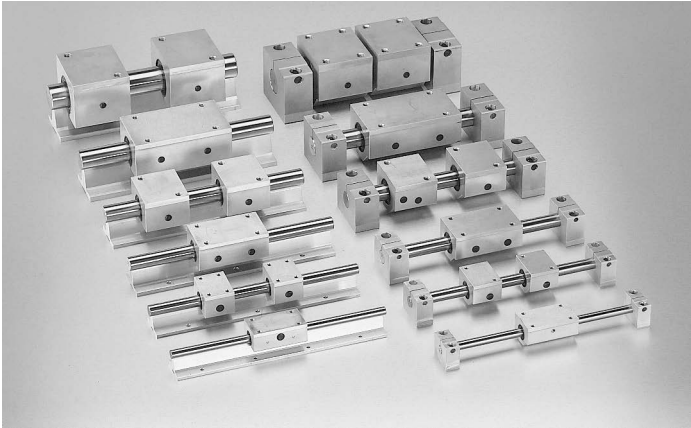

Thomson Pillow Blocks with factory-installed Super Smart Ball Bushing Bearings offer:

- Up to 6 times the load capacity or 216 times the travel life and 5 times the LinearRace shaft life when replacing conventional linear bearing pillow blocks.
- Accelerations as high as 150 m/s² and steady state travel speeds up to 3 m/s without the derating factors commonly required with linear guides.
- Replaceable bearing components for quick, cost effective machine maintenance and minimal downtime.
- Standard, double-acting, integral seals at both ends which keep out dirt, grit and other contaminants, retain lubrication and maximize bearing life.
- Adjustable, closed, and open styles.
- Lubrication hole for easy maintenance.
- Tapped or thru hole mounting configuration for ease of installation.
- Twin version with two Super Smart Ball Bushing Bearings providing twice the load capacity or 8 times more travel life than the single version.
- A single bearing version that self aligns in all directions, minimizing installation time and cost.

Note: See page 127 for information on Thomson Super Smart Ball Bushing Bearings.

Metric – Super Smart Pillow Blocks

Part Number Description and Specification

Super Smart Ball Bushing Bearings (Closed Type) for End Supported Applications

SSETWNM160PNWW-CR

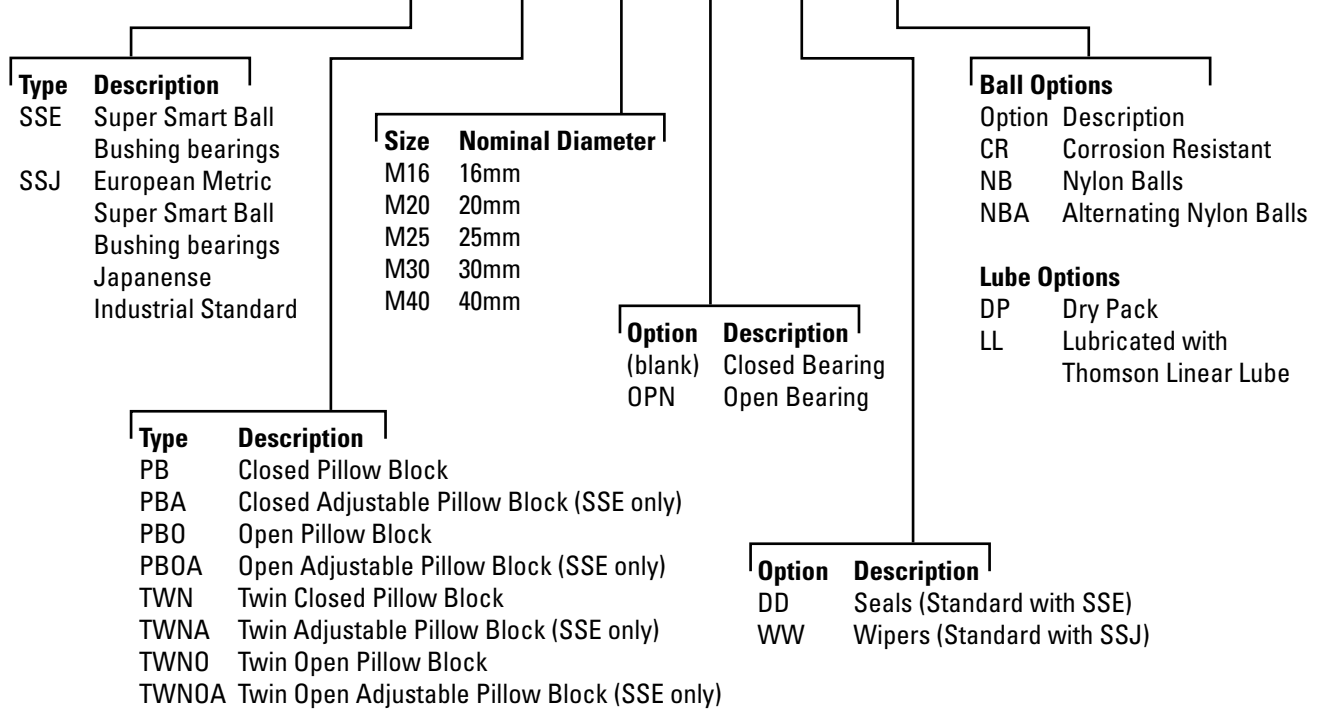

Metric Ball Bearing Bushing

For addition information on bearing options see page 273.

Metric – Super Smart Pillow Blocks

Super Smart Pillow Blocks

(Closed Type)

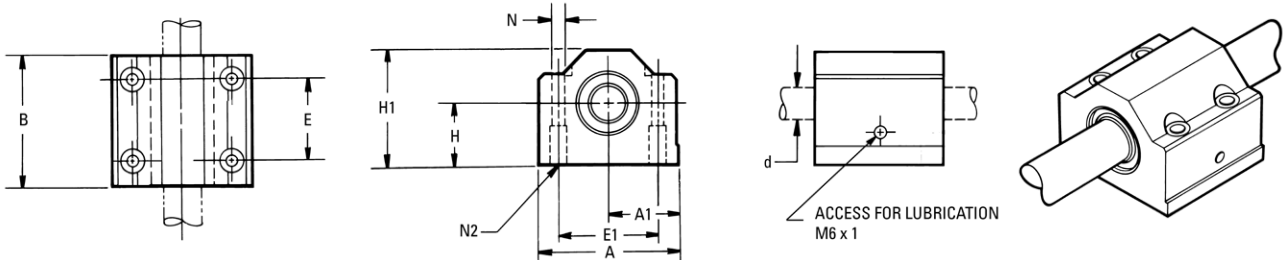

Super Smart Pillow Blocks (Closed Type) (Dimensions in mm)

Part Number	d ⁽⁵⁾	H ± 0,020	H1	A	A1 ± 0,020	B	E ± 0,1	E1 ± 0,1	N Dia.	N2	Mass (kg)	Dynamic Load W _d ⁽¹⁾⁽³⁾ (N)	Load Limit W ₀ ⁽²⁾⁽³⁾ (N)
SSE PB M16 DD	16	22	42	53	26,5	43	26	40	5,3	M6	0,21	2200	2400
SSE PB M20 DD	20	25	50	60	30,0	54	32	45	6,6	M8	0,35	4000	4400
SSE PB M25 DD	25	30	60	78	39,0	67	40	60	8,4	M10	0,67	6700	7300
SSE PB M30 DD	30	35	71	87	43,5	79	45	68	8,4	M10	0,99	8300	9100
SSE PB M40 DD	40	45	91	108	54,0	91	58	86	10,5	M12	1,84	13700	15000

(1) For rated travel life of 100 km. For longer travel lives, reduce load to $W \cdot (100/L)^{0,33}$ where L (km) is the required travel life. Do not exceed the Dynamic Load Rating for travel life of less than 100km.

(2) The Load Limit is the maximum load that may be applied to a bearing/shaft. It is important to analyze the application so the peak and/or shock loads do not exceed the Load Limit.

(3) For bearing diametral clearances, see Table 1.

NOTE: For additional technical information, see the Engineering section beginning on page 262.

**Table 1- Standard
Diametral Clearances
(Closed Type)**

Nominal Size d (mm)	Diametral Clearance (µm)
16	+26 +3
20	+30 +4
25	+30 +4
30	+30 +4
40	+35 +5

For Pillow Blocks used with
LinearRace Shaft, h6 tolerance

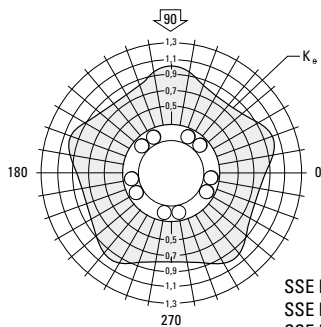

SSE PB M16 DD
SSE PB M20 DD
SSE PB M25 DD
SSE PB M30 DD
SSE PB M40 DD

Metric – Super Smart Pillow Blocks

Super Smart Pillow Blocks (Closed Adjustable Type)

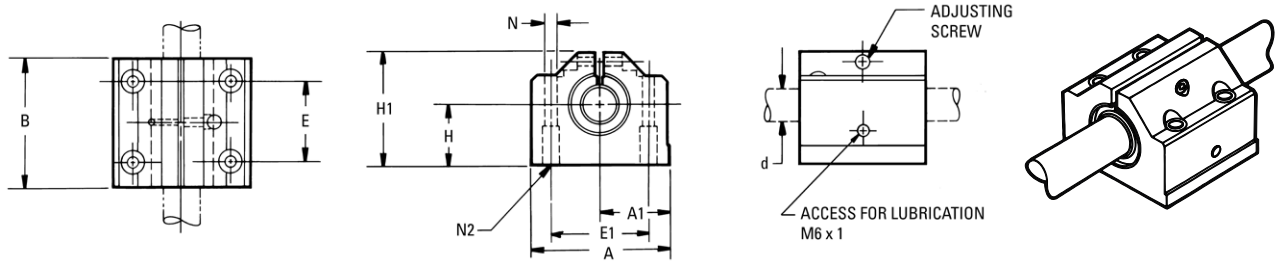

Super Smart Pillow Blocks (Closed Adjustable Type) (Dimensions in mm)

Part Number	d ⁽⁵⁾	H ± 0,020	H1	A	A1 ± 0,020	B	E ± 0,1	E1 ± 0,1	N Dia.	N2	Mass (kg)	Dynamic Load W ⁽¹⁾⁽²⁾ (N)	Load Limit W ₀ ⁽²⁾⁽⁴⁾ (N)
SSE PBA M16 DD	16	22	42	53	26,5	43	26	40	5,3	M6	0,21	2200	2400
SSE PBA M20 DD	20	25	50	60	30,0	54	32	45	6,6	M8	0,35	4000	4400
SSE PBA M25 DD	25	30	60	78	39,0	67	40	60	8,4	M10	0,67	6700	7300
SSE PBA M30 DD	30	35	71	87	43,5	79	45	68	8,4	M10	0,99	8300	9100
SSE PBA M40 DD	40	45	91	108	54,0	91	58	86	10,5	M12	1,84	13700	15000

(4) The load capacities W and W₀ are valid for a resultant load applied at 90° with the ball tracks oriented as shown in the polar graphs below. If the resultant acts along another direction, the appropriate multiplicative correction factor, K_q, should be applied to W and W₀ respectively. Open type bearings have reduced load capacities when used in pull-off situations.

(5) Adjusted to nominal.

NOTE: For additional technical information, see the Engineering section beginning on page 262.

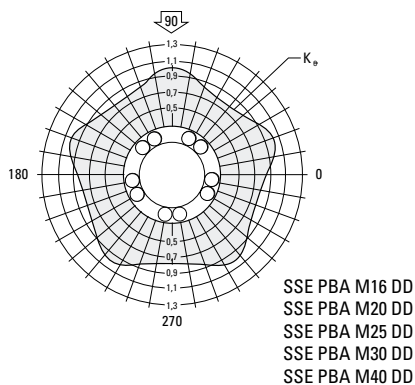

Metric – Super Smart Pillow Blocks

Super Smart Pillow Blocks (Open Type)

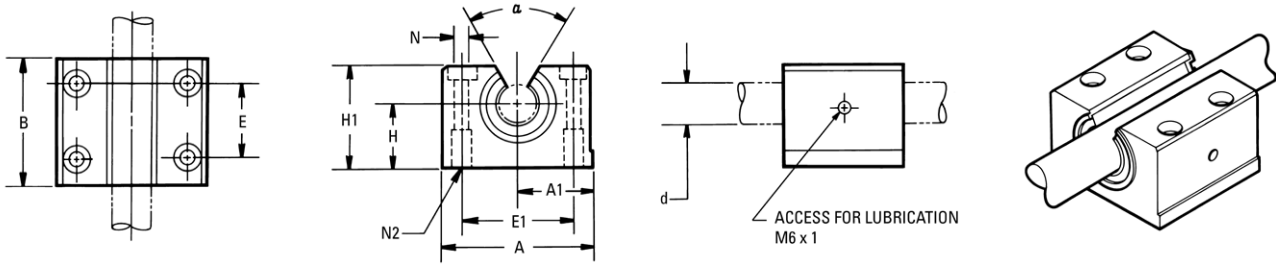

Super Smart Pillow Blocks (Open Type) (Dimensions in mm)

Part Number	d ⁽⁵⁾	H ± 0,020	H1	A	A1 ± 0,020	B	E ± 0,1	E1 ± 0,1	N Dia.	N2	Angle α (deg)	Mass (kg)	Dynamic Load W ⁽¹⁾⁽²⁾ (N)	Load Limit W ₀ ⁽²⁾⁽⁴⁾ (N)
SSE PBO M16 DD	16	22	35	53	26,5	43	26	40	5,3	M6	70	0,19	2200	2400
SSE PBO M20 DD	20	25	42	60	30,0	54	32	45	6,6	M8	50	0,30	4000	4400
SSE PBO M25 DD	25	30	51	78	39,0	67	40	60	8,4	M10	60	0,60	6700	7300
SSE PBO M30 DD	30	35	60	87	43,5	79	45	68	8,4	M10	55	0,93	8300	9100
SSE PBO M40 DD	40	45	77	108	54,0	91	58	86	10,5	M12	54	1,66	13700	15000

(1) For rated travel life of 100 km. For longer travel lives, reduce load to $W \cdot (100/L)^{0,33}$ where L (km) is the required travel life. Do not exceed the Dynamic Load Rating for travel life of less than 100km.

(2) The Load Limit is the maximum load that may be applied to a bearing/shaft. It is important to analyze the application so that peak and/or shock loads do not exceed the Load Limit.

(3) For bearing diametral clearances, see Table 2.

NOTE: For additional technical information, see the Engineering section beginning on page 262.

Table 2 - Standard Diametral Clearances (Open Type)

Nominal Size d (mm)	Diametral Clearance (μm)
16	+26 +3
20	+30 +4
25	+30 +4
30	+30 +4
40	+35 +5

For Pillow Blocks used with LinearRace Shaft, h6 tolerance

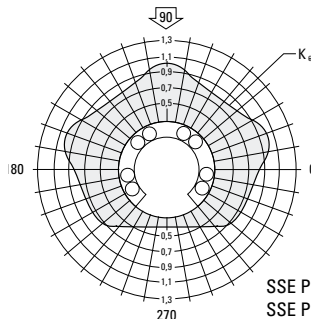

SSE PBO M16 DD
SSE PBO M20 DD
SSE PBO M25 DD
SSE PBO M30 DD
SSE PBO M40 DD

Metric – Super Smart Pillow Blocks

Super Smart Pillow Blocks (Open Adjustable Type)

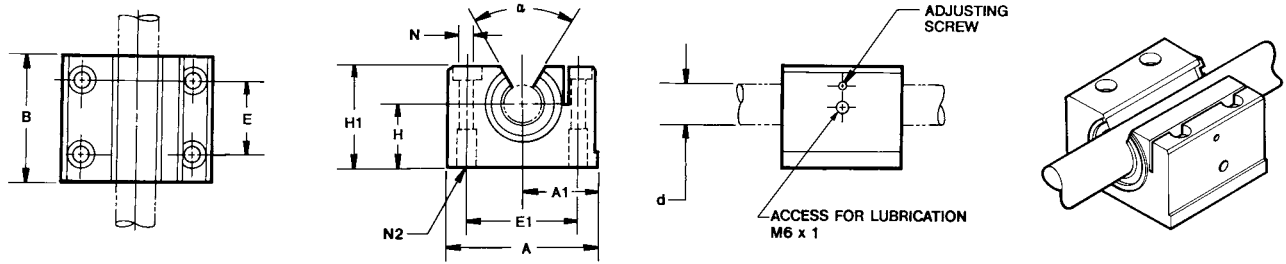

Super Smart Pillow Blocks (Open Adjustable Type) (Dimensions in mm)

Part Number	d ⁽⁵⁾	H ± 0,020	H1	A	A1 ± 0,020	B	E ± 0,1	E1 ± 0,1	N Dia.	N2	Angle α (deg)	Mass (kg)	Dynamic Load W ⁽¹⁾⁽²⁾ (N)	Load Limit W ₀ ⁽²⁾⁽⁴⁾ (N)
SSE PBOA M16 DD	16	22	35	53	26,5	43	26	40	5,3	M6	70	0,19	2200	2400
SSE PBOA M20 DD	20	25	42	60	30,0	54	32	45	6,6	M8	50	0,30	4000	4400
SSE PBOA M25 DD	25	30	51	78	39,0	67	40	60	8,4	M10	60	0,60	6700	7300
SSE PBOA M30 DD	30	35	60	87	43,5	79	45	68	8,4	M10	55	0,93	8300	9100
SSE PBOA M40 DD	40	45	77	108	54,0	91	58	86	10,5	M12	54	1,66	13700	15000

(4) The load capacities W and W₀ are valid for a resultant load applied at 90° with the ball tracks oriented as shown in the polar graphs below. If the resultant acts along another direction, the appropriate multiplicative correction factor, K_q, should be applied to W and W₀ respectively. Open type bearings have reduced load capacities when used in pull-off situations.

(5) Adjusted to nominal.

NOTE: For additional technical information, see the Engineering section beginning on page 262.

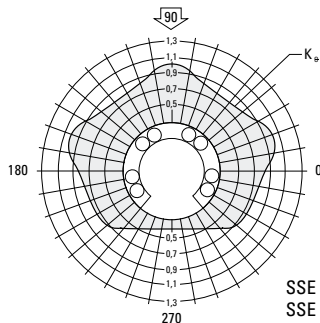

SSE PBOA M16 DD
SSE PBOA M20 DD
SSE PBOA M25 DD
SSE PBOA M30 DD
SSE PBOA M40 DD

Metric – Super Smart Pillow Blocks

Super Smart Twin Pillow Blocks (Closed Type)

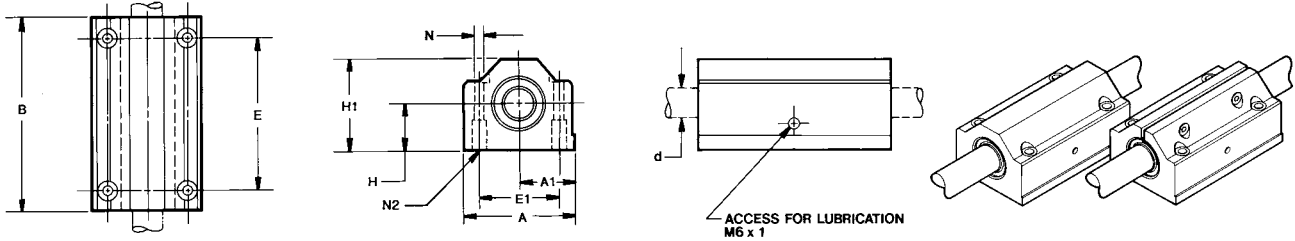

Super Smart Twin Pillow Blocks (Closed Type) (Dimensions in mm)

Part Number	d ⁽⁵⁾	H ± 0,020	H1	A	A1 ± 0,020	B	E ± 0,1	E1 ± 0,1	N Dia.	N2	Mass (kg)	Dynamic Load W ₀ ⁽¹⁾⁽²⁾ (N)	Load Limit W ₀ ⁽²⁾⁽⁴⁾ (N)
SSE TWN M16 DD	16	22	42	53	26,5	84	64	40	5,3	M6	0,41	4400	4800
SSE TWN M20 DD	20	25	51	60	30,0	104	76	45	6,6	M8	0,67	8000	8800
SSE TWN M25 DD	25	30	60	78	39,0	130	94	60	8,4	M10	1,24	13400	14600
SSE TWN M30 DD	30	35	71	87	43,5	152	106	68	8,4	M10	1,94	16600	18200
SSE TWN M40 DD	40	45	91	108	54,0	176	124	86	10,5	M12	3,63	27400	30000

(Closed Adjustable Type)

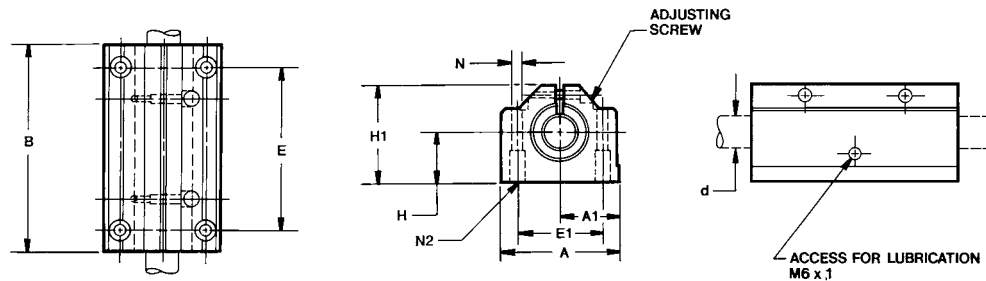

Super Smart Twin Pillow Blocks (Closed Adjustable Type) (Dimensions in mm)

Part Number	d ⁽⁵⁾	H ± 0,020	H1	A	A1 ± 0,020	B	E ± 0,1	E1 ± 0,1	N Dia.	N2	Mass (kg)	Dynamic Load W ₀ ⁽¹⁾⁽²⁾ (N)	Load Limit W ₀ ⁽²⁾⁽⁴⁾ (N)
SSE TWNA M16 DD	16	22	42	53	26,5	84	64	40	5,3	M6	0,41	4400	4800
SSE TWNA M20 DD	20	25	50	60	30,0	104	76	45	6,6	M8	0,67	8000	8800
SSE TWNA M25 DD	25	30	60	78	39,0	130	94	60	8,4	M10	1,24	13400	14600
SSE TWNA M30 DD	30	35	71	87	43,5	152	106	68	8,4	M10	1,94	16600	18200
SSE TWNA M40 DD	40	45	91	108	54,0	176	124	86	10,5	M12	3,63	27400	30000

See footnotes (1) (2) (3) (4) (5) on pages 140-141. For diametral clearances, see single versions of pillow block.

Metric – Super Smart Pillow Blocks

Super Smart Twin Pillow Blocks (Open Type)

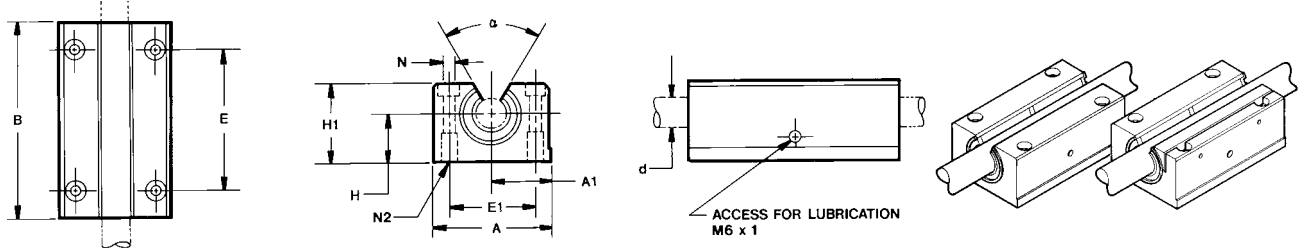

Super Smart Twin Pillow Blocks (Open Type) (Dimensions in mm)

Part Number	d ⁽⁵⁾	H ± 0,020	H1	A	A1 ± 0,020	B	E ± 0,1	E1 ± 0,1	N Dia.	N2	Angle α (deg)	Mass (kg)	Dynamic Load W ₀ ⁽¹⁾⁽²⁾ (N)	Load Limit W ₀ ⁽²⁾⁽⁴⁾ (N)
SSE TWNO M16 DD	16	22	35	53	26,5	84	64	40	5,3	M6	70	0,37	4400	4800
SSE TWNO M20 DD	20	25	41	60	30,0	104	76	45	6,6	M8	50	0,58	8000	8800
SSE TWNO M25 DD	25	30	50	78	39,0	130	94	60	8,4	M10	60	1,16	13400	14600
SSE TWNO M30 DD	30	35	60	87	43,5	152	106	68	8,4	M10	55	1,78	16600	18200
SSE TWNO M40 DD	40	45	77	108	54,0	176	124	86	10,5	M12	54	3,25	27400	30000

(Open Adjustable Type)

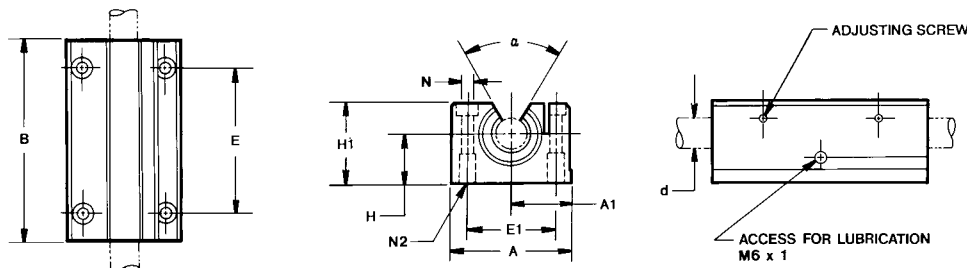

Super Smart Twin Pillow Blocks (Open Adjustable Type) (Dimensions in mm)

Part Number	d ⁽⁵⁾	H ± 0,020	H1	A	A1 ± 0,020	B	E ± 0,1	E1 ± 0,1	N Dia.	N2	Angle α (deg)	Mass (kg)	Dynamic Load W ₀ ⁽¹⁾⁽²⁾ (N)	Load Limit W ₀ ⁽²⁾⁽⁴⁾ (N)
SSE TWNOA M16 DD	16	22	35	53	26,5	84	64	40	5,3	M6	70	0,37	4400	4800
SSE TWNOA M20 DD	20	25	41	60	30,0	104	76	45	6,6	M8	50	0,58	8000	8800
SSE TWNOA M25 DD	25	30	50	78	39,0	130	94	60	8,4	M10	60	1,16	13400	14600
SSE TWNOA M30 DD	30	35	60	87	43,5	152	106	68	8,4	M10	55	1,78	16600	18200
SSE TWNOA M40 DD	40	45	77	108	54,0	176	124	86	10,5	M12	54	3,25	27400	30000

See footnotes (1) (2) (3) (4) (5) on pages 140-141. For diametral clearances, see single versions of pillow block.

Metric – Super Smart Pillow Blocks

**Super Smart Pillow Blocks - JIS Specifications
(Closed Type)**

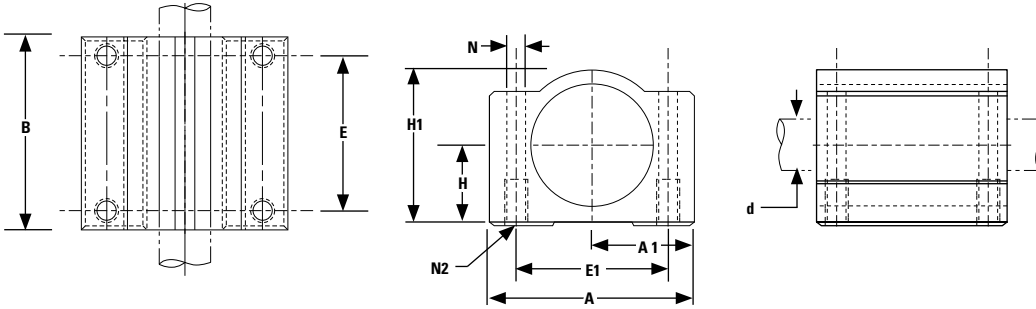

Designed to be used for new or existing JIS (Japanese Industrial Standard) designs

Part Number	d ⁽⁵⁾	H ± 0,020	H1	A	A1 ± 0,020	B	E ± 0,1	E1 ± 0,1	N Dia.	N2	Mass (kg)	Dynamic Load W ₀ ⁽¹⁾⁽³⁾ (N)	Load Limit W ₀ ⁽²⁾⁽³⁾ (N)
SSJ PB M16	16	19	37	50	25	44	34	36	4,3	M5	0,21	2200	2400
SSJ PB M20	20	21	41	54	27	50	40	40	5,2	M6	0,35	4000	4400
SSJ PB M25	25	26	51	76	38	67	50	54	7	M8	0,67	6700	7300
SSJ PB M30	30	30	57	78	39	72	58	58	7	M8	0,99	8300	9100
SSJ PB M40	40	40	75	102	51	90	60	80	8,7	M10	1,84	13700	15000

(1) For rated travel life of 100 km. For longer travel lives, reduce load to $W \cdot (100/L)^{0.33}$ where L (km) is the required travel life. Do not exceed the Dynamic Load Rating for travel life of less than 100km.

(2) The Load Limit is the maximum load that may be applied to a bearing/shaft. It is important to analyze the application so the peak and/or shock loads do not exceed the Load Limit.

(3) For bearing diametral clearances, see Table 1.

NOTE: For additional technical information, see the Engineering section beginning on page 262.

**Table 1- Standard
Diametral Clearances
(Closed Type)**

Nominal Size d (mm)	Diametral Clearance (µm)
16	+26 +3
20	+30 +4
25	+30 +4
30	+30 +4
40	+35 +5

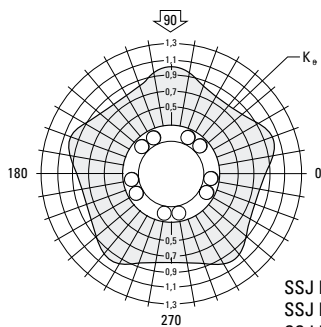

SSJ PB M16
SSJ PB M20
SSJ PB M25
SSJ PB M30
SSJ PB M40

For Pillow Blocks used with LinearRace Shaft, h6 tolerance

Metric – Super Smart Pillow Blocks

Super Smart Pillow Blocks - JIS Specifications (Open Type)

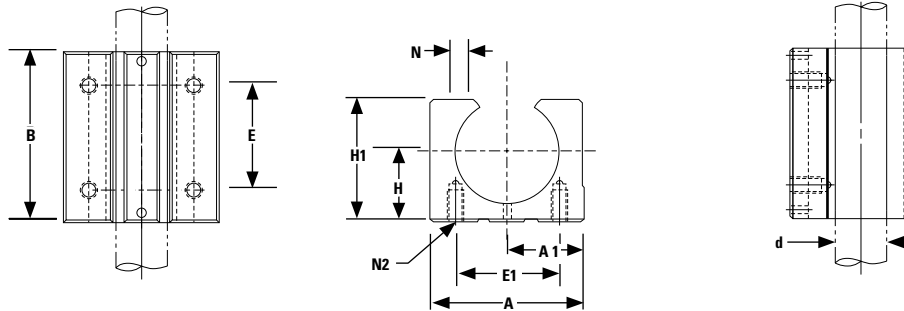

Designed to be used for new or existing JIS (Japanese Industrial Standard) designs

Part Number	d ⁽⁵⁾	H ± 0,020	H1	A	A1 ± 0,020	B	E ± 0,1	E1 ± 0,1	N Dia.	N2	Mass (kg)	Dynamic Load W _d ⁽¹⁾⁽²⁾ (N)	Load Limit W _L ⁽²⁾⁽⁴⁾ (N)
SSJ PBO M16	16	20	33	45	22,5	45	30	32	5	M5	0,19	2200	2400
SSJ PBO M20	20	23	38	48	24	50	35	35	6	M6	0,30	4000	4400
SSJ PBO M25	25	27	47	60	30	65	40	40	6	M6	0,60	6700	7300
SSJ PBO M30	30	33	55	70	35	70	50	50	8	M8	0,93	8300	9100
SSJ PBO M40	40	42	72	90	45	90	65	65	10	M10	1,66	13700	15000

- (1) For rated travel life of 100 km. For longer travel lives, reduce load to $W \cdot (100/L)^{0.33}$ where L (km) is the required travel life. Do not exceed the Dynamic Load Rating for travel life of less than 100km.
- (2) The Load Limit is the maximum load that may be applied to a bearing/shaft. It is important to analyze the application so that peak and/or shock loads do not exceed the Load Limit.
- (3) For bearing diametral clearances, see Table 2.

NOTE: For additional technical information, see the Engineering section beginning on page 262.

Table 2 - Standard Diametral Clearances (Open Type)

Nominal Size d (mm)	Diametral Clearance (µm)
16	+26 +3
20	+30 +4
25	+30 +4
30	+30 +4
40	+35 +5

For Pillow Blocks used with LinearRace Shaft, h6 tolerance

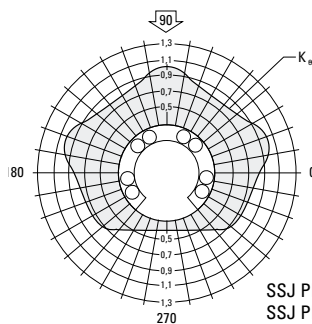

SSJ PBO M16
SSJ PBO M20
SSJ PBO M25
SSJ PBO M30
SSJ PBO M40

Metric – Super Smart Pillow Blocks

Super Smart Twin Pillow Blocks - JIS Specifications (Closed Type)

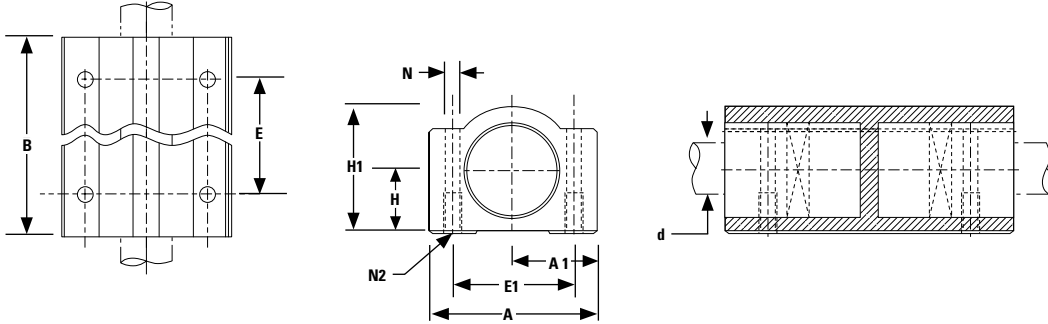

Designed to be used for new or existing JIS (Japanese Industrial Standard) designs

Part Number	d ⁽⁵⁾	H ± 0,020	H1	A	A1 ± 0,020	B	E ± 0,1	E1 ± 0,1	N Dia.	N2	Mass (kg)	Dynamic Load W ₀ ⁽¹⁾⁽²⁾ (N)	Load Limit W ₀ ⁽²⁾⁽⁴⁾ (N)
SSJ TWN M16	16	19	37	50	25	85	60	36	4,3	M5	0,41	4400	4800
SSJ TWN M20	20	21	41	54	27	96	70	40	5,2	M6	0,67	8000	8800
SSJ TWN M25	25	26	51	76	38	130	100	54	7	M8	1,24	13400	14600
SSJ TWN M30	30	30	57	78	39	140	110	58	7	M8	1,94	16600	18200
SSEJTWN M40	40	40	75	102	51	175	140	80	8,7	M10	3,63	27400	30000

(Open Type)

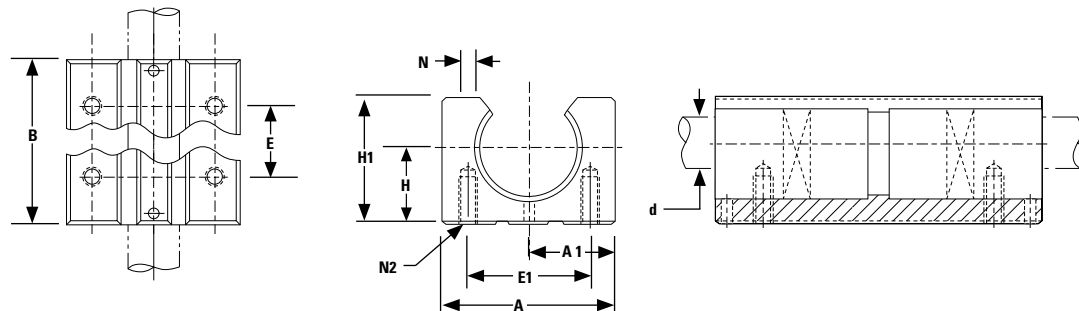

Designed to be used for new or existing JIS (Japanese Industrial Standard) designs

Part Number	d ⁽⁵⁾	H ± 0,020	H1	A	A1 ± 0,020	B	E ± 0,1	E1 ± 0,1	N Dia.	N2	Mass (kg)	Dynamic Load W ₀ ⁽¹⁾⁽²⁾ (N)	Load Limit W ₀ ⁽²⁾⁽⁴⁾ (N)
SSJ TWNO M16	16	20	33	45	27,5	85	60	32	5	M5	0,41	4400	4800
SSJ TWNO M20	20	23	38	48	24	96	70	35	6	M6	0,67	8000	8800
SSJ TWNO M25	25	27	47	60	30	130	100	40	6	M6	1,24	13400	14600
SSJ TWNO M30	30	33	55	70	35	140	110	50	8	M8	1,94	16600	18200
SSJ TWNO M40	40	42	72	90	45	175	140	65	10	M10	3,63	27400	30000

See footnotes (1) (2) (3) (4) (5) on pages 144-145. For diametral clearances, see single versions of pillow block.

Metric – Super Smart Pillow Blocks

Application Punch Press

Objective

Reduce deflection of plate loader to minimize scrap and improve cycle speed.

Solution

Replace super type linear bearings with Super Smart pillow blocks and Smart Rail assemblies to improve accuracy, load capacity, service life, efficiency and reduce downtime.

Products Specified

4 - SSE PBOA M25 DD (Super Smart Pillow Blocks)
2 - LSRA M25 T4 900 mm Smart Rail assemblies

Benefits

By retrofitting with Super Smart Pillow Blocks, machine productivity increased 700%. Smart Rail assemblies provided reduced deflection during plate loading. The retrofit required minimum downtime due to the pillow blocks' ease of installation.

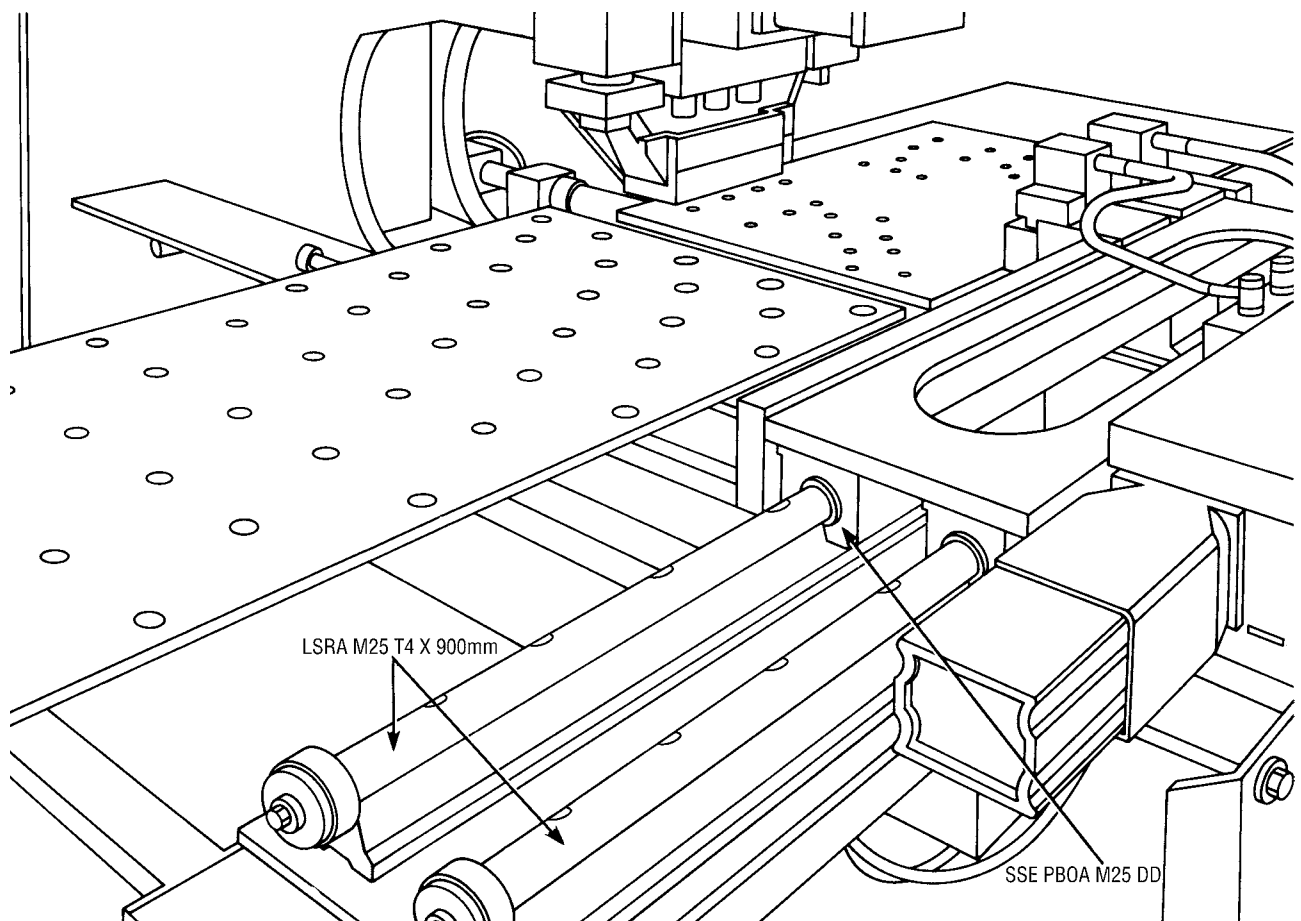

Metric – MultiTrac Ball Bushing Bearings

MultiTrac Ball Bushing Bearings



Thomson MultiTrac Ball Bushing Bearings offer:

- Patented, multiple-track design with up to twice the load carrying capacity, or 8 times the life, of conventional linear bearings.
- Rigid design for minimal deflection assuring accurate, precise positioning.
- Coefficient of friction as low as 0,001.
- Patented ball control technology which eliminates binding and chatter (stick-slip) common to high-friction, plain bushings and sliding-way bearings.
- RoundRail Advantage which, combined with the advanced MultiTrac Ball Bushing Bearing design, eliminates the need for the derating factors commonly required with square rail linear guides.
- Steady state speeds up to 3 m/s and accelerations up to 150 m/s², without the use of derating factors.
- Wear-resistant, engineered-polymer retainers to reduce inertia and noise levels.
- Adjustable, closed and open configurations.
- Stainless steel (440C) option available in all sizes for for corrosive environments.

Metric – MultiTrac Ball Bushing Linear bearings

Part Number Description and Specification

Super Smart Ball Bushing Bearings (Closed Type) for End Supported Applications

MAM160PNWW-SS

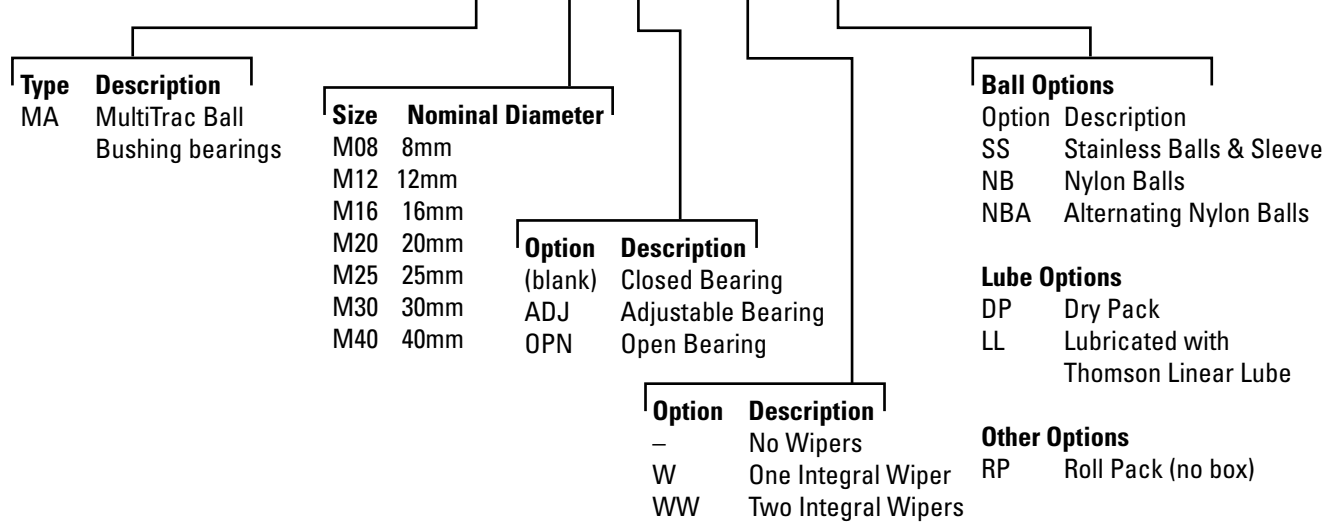

Metric Ball Bushing

For addition information on bearing options see page 273.

Metric – MultiTrac Ball Bushing Bearings

MultiTrac Ball Bushing Bearings (Closed Type)

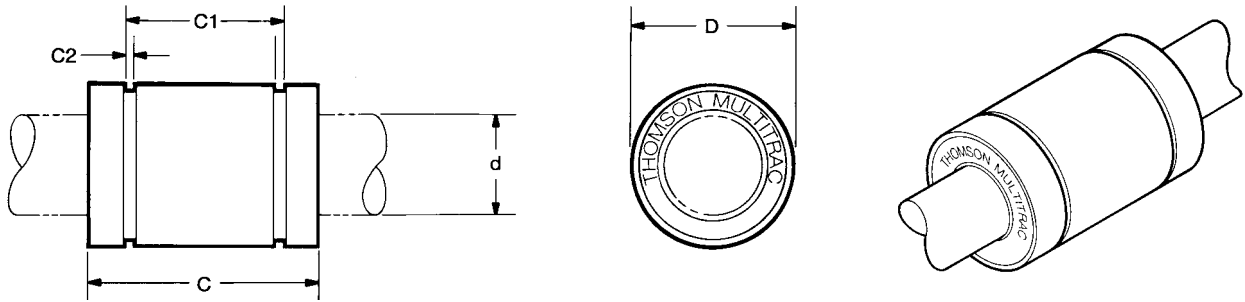

MultiTrac Ball Bushing Linear Bearings (Closed Type) (Dimensions in mm)

Part Number			d ⁽⁴⁾	D	C h14	C1 H13	C2 min.	Number of ball tracks	Mass (kg)	Dynamic Load W ⁽¹⁾⁽³⁾ (N)	Load Limit W ₀ ⁽²⁾⁽³⁾ (N)
Without Integral Wipers	With one Integral Wiper	With two Integral Wipers									
MA M08	MA M08 W	MA M08 WW	8	16	25	16,2	1,10	4	0,02	180	330
MA M12	MA M12 W	MA M12 WW	12	22	32	22,6	1,30	5	0,04	350	880
MA M16	MA M16 W	MA M16 WW	16	26	36	24,6	1,30	8	0,06	550	1300
MA M20	MA M20 W	MA M20 WW	20	32	45	31,2	1,60	8	0,11	1000	2360
MA M25	MA M25 W	MA M25 WW	25	40	58	43,7	1,85	8	0,20	1980	5100
MA M30	MA M30 W	MA M30 WW	30	47	68	51,7	1,85	8	0,33	2060	5800
MA M40	MA M40 W	MA M40 WW	40	62	80	60,3	2,15	8	0,63	3820	9250

(1) For rated travel life of 100 km. For longer travel lives, reduce load to $W \cdot (100/L)^{0.33}$ where L (km) is the required travel life. Do not exceed the Dynamic Load Rating for travel life of less than 100 km.

(2) The load Limit is the maximum load that may be applied to a bearing/shaft. It is important to analyze the application so that peak and/or shock loads do not exceed the Load Limit.

(3) For diametral clearance, see Table 1.

NOTE: External seals and retaining rings are available. See page 167 for specifications.

NOTE: For additional technical data, see Engineering Support section.

Table 1 - Standard Diametral Clearances Closed Type

Nominal Size d (mm)	Diametral Clearance (µm)
8	+15 +3
12	+19 +3
16	+19 +3
20	+22 +4
25	+22 +4
30	+22 +4
40	+27 +5

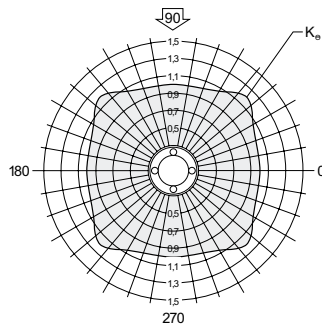

MA M16 MA M16 ADJ
MA M20 MA M20 ADJ
MA M25 MA M25 ADJ
MA M30 MA M30 ADJ
MA M40 MA M40 ADJ

Table 2 - Stainless Steel Part Numbers

Part Number		
Without Integral Wipers	With One Integral Wiper	With Two Integral Wipers
MAM08SS	MAM08WSS	MAM08WWSS
MAM12SS	MAM12WSS	MAM12WWSS
MAM16SS	MAM16WSS	MAM16WWSS
MAM20SS	MAM20WSS	MAM20WWSS
MAM25SS	MAM25WSS	MAM25WWSS
MAM30SS	MAM30WSS	MAM30WWSS

All dimensional information and load ratings for the stainless steel MultiTrac Ball Bushing Bearings are identical to those shown above. If run on stainless steel shafting, load ratings of these bearings are 80% of the above stated values.

For closed type bearings with LinearRace shaft, h6 tolerance

Metric – MultiTrac Ball Bushing Linear bearings

MultiTrac Ball Bushing Linear bearings

(Closed adjustable type)

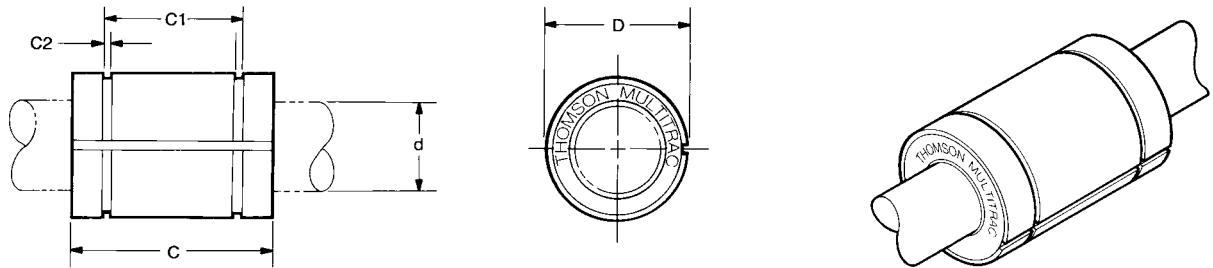

MultiTrac Ball Bushing Linear Bearings (Closed Adjustable Type) (Dimensions in mm)

Part Number			d ⁽⁴⁾	D	C h14	C1 H13	C2 min.	Number of ball tracks	Mass (kg)	Dynamic Load W ⁽¹⁾⁽³⁾ (N)	Load Limit W ₀ ⁽²⁾⁽³⁾ (N)
Without Integral Wipers	With one Integral Wiper	With two Integral Wipers									
MA M08 ADJ	MA M08 ADJ W	MA M08 ADJ WW	8	16	25	16,2	1,10	4	0,002	180	330
MA M12 ADJ	MA M12 ADJ W	MA M12 ADJ WW	12	22	32	22,6	1,30	6	0,04	350	880
MA M16 ADJ	MA M16 ADJ W	MA M16 ADJ WW	16	26	36	24,6	1,30	8	0,06	550	1300
MA M20 ADJ	MA M20 ADJ W	MA M20 ADJ WW	20	32	45	31,2	1,60	8	0,11	1000	2360
MA M25 ADJ	MA M25 ADJ W	MA M25 ADJ WW	25	40	58	43,7	1,85	8	0,20	1980	5100
MA M30 ADJ	MA M30 ADJ W	MA M30 ADJ WW	30	47	68	51,7	1,85	8	0,33	2060	5800
MA M40 ADJ	MA M40 ADJ W	MA M40 ADJ WW	40	62	80	60,3	2,15	8	0,63	3820	9250

(4) The load capacities W and Wq are valid for a resultant load applied at 90° with the ball tracks oriented as shown in the polar graphs below. If the resultant acts along another direction, the appropriate multiplicative correction factor Kq, should be applied to W and Wq respectively. Open type bearings have reduced load capacities when used in pull-off situations.

(5) Diametral fit-up is determined by the housing diameter. See Table 2.

NOTE: External seals and retaining are available. See page 167 for specifications.

NOTE: For additional technical information, see the Engineering section beginning on page 262.

Table 3 - Standard Diametral Clearances Adjustable and Open Type

Nominal Shaft Diameter d (mm)	Diametral Housing Bore H6 (µm)
8	+28 +7
12	+33 +9
16	+33 +9
20	+40 +10
25	+40 +10
30	+40 +10
40	+48 +12

For adjustable and open type bearings with LinearRace shaft, h6 tolerance

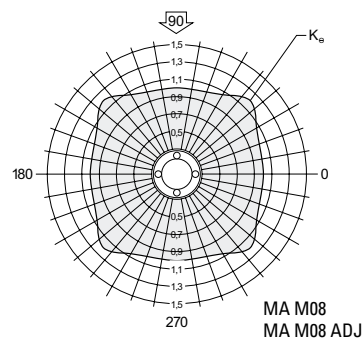
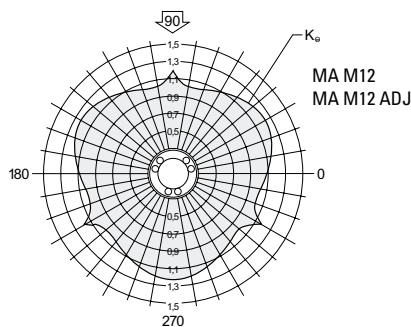

Table 4 - Stainless Steel Part Numbers

Part Number		
Without Integral Wipers	With One Integral Wiper	With Two Integral Wipers
MAM08ADJSS	MAM08ADJWSS	MAM08ADJWWSS
MAM12ADJSS	MAM12ADJWSS	MAM12ADJWWSS
MAM16ADJSS	MAM16ADJWSS	MAM16ADJWWSS
MAM20ADJSS	MAM20ADJWSS	MAM20ADJWWSS
MAM25ADJSS	MAM25ADJWSS	MAM25ADJWWSS
MAM30ADJSS	MAM30ADJWSS	MAM30ADJWWSS

All dimensional information and load ratings for the stainless steel MultiTrac Ball Bushing Bearings are identical to those shown above.

Metric – MultiTrac Ball Bushing Bearings

**MultiTrac Ball Bushing Bearings
(Open Type)**

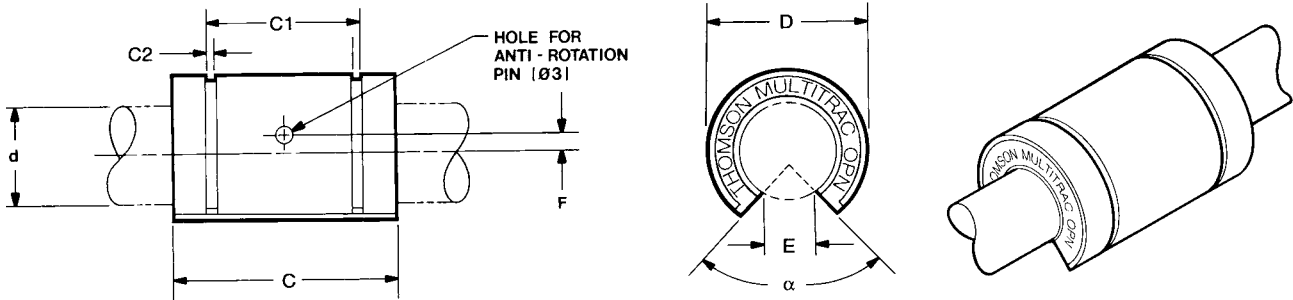

MultiTrac Ball Bushing Linear Bearings (Open Type) (Dimensions in mm)

Part Number			d ⁽⁴⁾	D	C h14	C1 H13	C2 min.	E	F	Angle α (deg)	Number of ball tracks	Mass (kg)	Dynamic Load W ⁽¹⁾⁽³⁾ (N)	Load Limit W ₀ ⁽²⁾⁽³⁾ (N)
Without Integral Wipers	With one Integral Wiper	With two Integral Wipers												
MAM120PN	MAM120PNW	MAM120PNWW	12	22	32	22,6	1,30	7,3	1,35	120	4	0,04	440	1100
MAM160PN	MAM160PNW	MAM160PNWW	16	26	36	24,6	1,30	10,6	0	90	6	0,06	600	1500
MAM200PN	MAM200PNW	MAM200PNWW	20	32	45	31,2	1,60	11,5	0	90	6	0,11	1100	2720
MAM250PN	MAM250PNW	MAM250PNWW	25	40	58	43,7	1,85	13,9	1,50 ⁽⁶⁾	90	6	0,20	2170	5300
MAM300PN	MAM300PNW	MAM300PNWW	30	47	68	51,7	1,85	20,3	2,00	90	6	0,33	2260	6710
MAM400PN	MAM400PNW	MAM400PNWW	40	62	80	60,3	2,15	20,9	1,50	90	6	0,63	4200	10700

(6) Hole for anti-rotation pin is below centerline.

For footnotes 1-5, see pages 146-147.

Note: External seals and retaining rings are available. See page 167 for specifications.

NOTE: For additional technical information, see the Engineering section beginning on page 262.

Table 5 - Stainless Steel Part Numbers

Part Number		
Without Integral Wipers	With One Integral Wiper	With Two Integral Wipers
MAM120PNSS	MAM120PNWSS	MAM120PNWWSS
MAM160PNSS	MAM160PNWSS	MAM160PNWWSS
MAM200PNSS	MAM200PNWSS	MAM200PNWWSS
MAM250PNSS	MAM250PNWSS	MAM250PNWWSS
MAM300PNSS	MAM300PNWSS	MAM300PNWWSS

All dimensional information and load ratings for the stainless steel MultiTrac Ball Bushing Bearings are identical to those shown above.

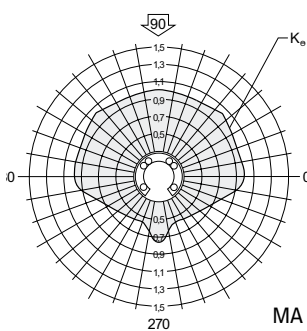

MA M16 OPN
MA M20 OPN
MA M25 OPN
MA M30 OPN
MA M40 OPN

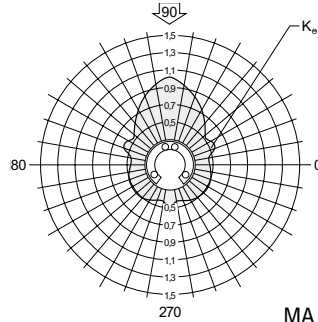

MA M12 OPN

Metric – MultiTrac Ball Bushing Bearings

MultiTrac Ball Bushing Bearings

Our Thomson MultiTrac Ball Bushing Bearings are designed with greater rigidity and up to twice the load capacity of conventional linear bearings. The design incorporates a one-piece, bearing quality steel sleeve (see Figure 1) for maximum rigidity. The single-piece engineered polymer ball retainer provides smooth, quiet operation.

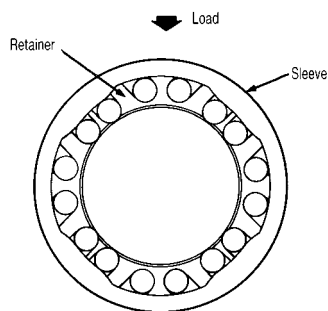

Figure 1

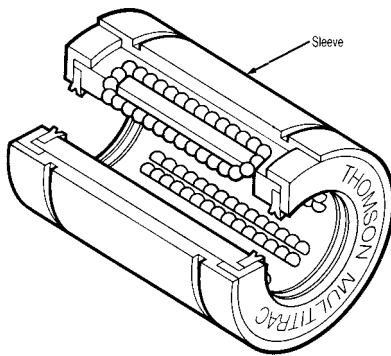

Figure 2

Twice the Load Capacity

The bearing's load capacity is improved by the optimal positioning of the load tracks. This places the maximum number of load-bearing balls in the load zone (see Figure 1).

High Speed Operation

The advanced design also improves the bearing's ball control. This allows accelerations as high as 150 m/s² and travel speeds up to 3 m/s.

Integral Seals

The bearing includes double acting integral wipers, which keep out dirt, grit and other contaminants, and retain bearing lubrication.

Improved Ball Control

Through advanced computer-aided design techniques, ball control improvements assure smooth entry and exit of the balls in and out of the load zone.

Ideal for Corrosive Environments

Optional stainless steel (440C) resists rust and corrosion.

Metric – MultiTrac Ball Bushing Bearings

Application

Wire Straightening/Feeding Machine

Objective

Redesign a wire straightening/feeding mechanism for a wire drawing machine that improves cycle time and minimizes downtime.

Solution

Combine the performance advantages of the MultiTrac Ball Bushing Linear bearings with the operating efficiency of Thomson all screws.

Products Specified

- 4 - MA M16 WW (MultiTrac Ball Bushing linear bearings)
- 2 - 16 MM X 600 MM (60 Case LinearRace shaft)
- 1 - 16 x 5 Thomson ball screw assembly

Benefits

Because MultiTrac Ball Bushing Linear bearings have twice the load capacity of conventional linear bearings, service life increased from six months to four years.

This significantly reduced downtime and maintenance requirements and provided increased productivity with substantial cost savings.

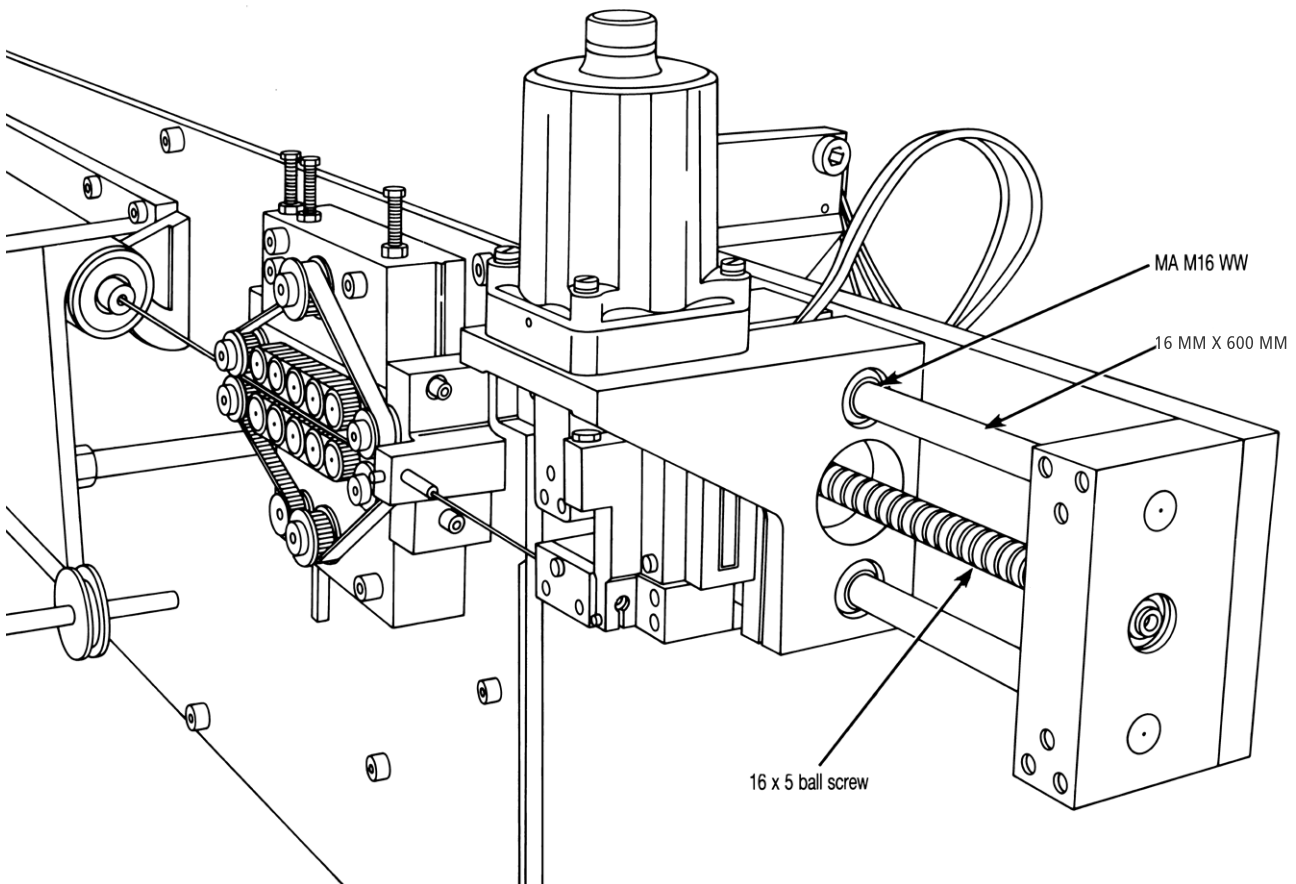

Metric – MultiTrac Ball Bushing Bearings

Application

Pick and Place X-Y System

Objective

Build an X-Y System that transfers the work piece between two separate machining stations.

Solution

Assemble the X-Y System utilizing Super Smart Ball Bushings Bearing pillow blocks on end supported shafts for the X-axis and continuous supported 60 Case LinearRace shaft on the Y-axis. Utilize Thomson Saginaw* ball screws for high speed positioning.

Products Specified

- X-axis
- 2 - 40 MM X 1200 MM (60 Case LinearRace)
- 4 - SB M40 (shaft support blocks)
- 4 - SSE PBA M40 DD (Super Smart pillow blocks)
- 1 - 32 x 5 Thomson ball screw assembly Y-axis
- 2 - LSRA M40 T5 X 1200 mm (Smart Rail™ guides)
- 4 - SSE PBOA M40 DD (Super Smart pillow blocks)
- 1 - 32 x 5 Thomson ball screw assembly

Benefits

The 60 Case LinearRace shafts and shaft support end blocks provided an important bridge between machining stations. The Super Smart pillow blocks and Thomson ball screws provided uninterrupted high speed movement of the work piece. Productivity increased by 200%

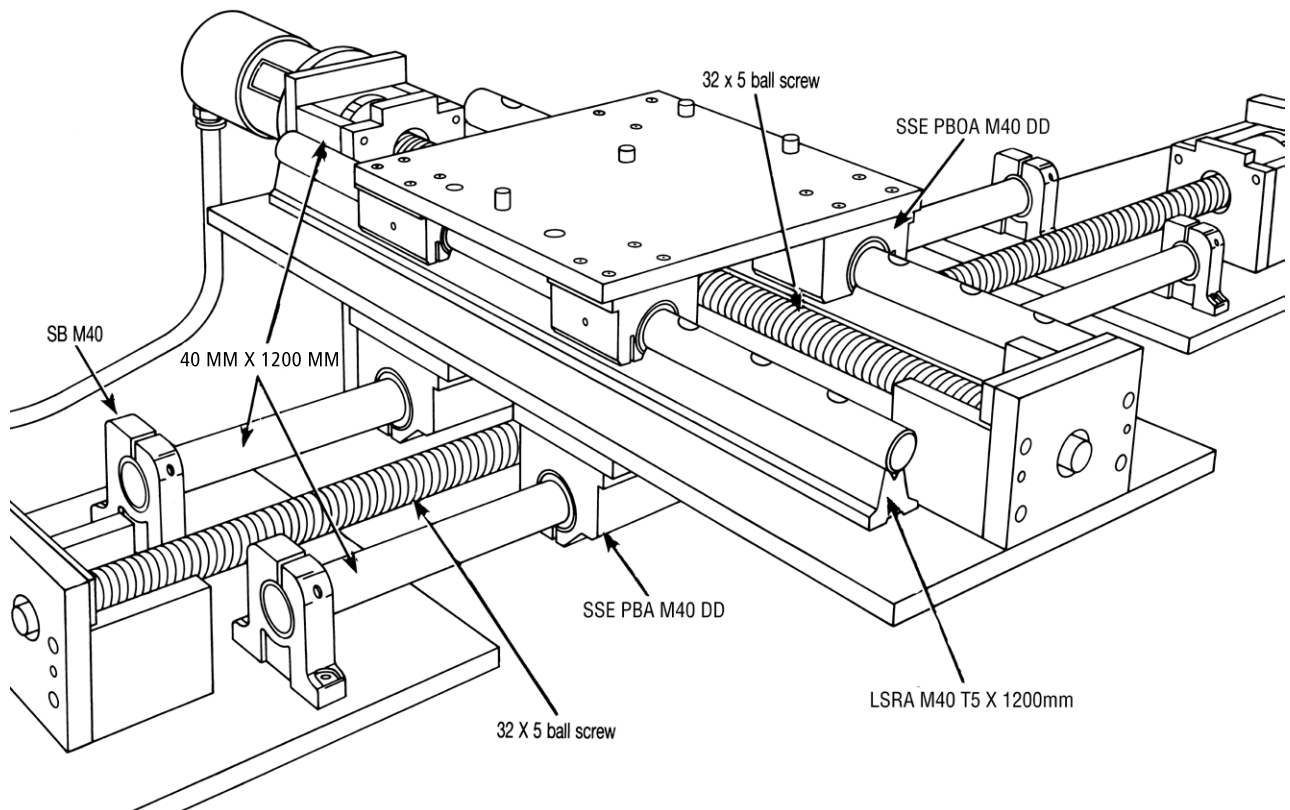

*Trademark of Thomson Industries Inc. Thomson Industries Inc. is registered in the U.S. Patent and Trademark Office and in other countries.

Metric – Super Ball Bushing Bearings

Super Ball Bushing* Bearings

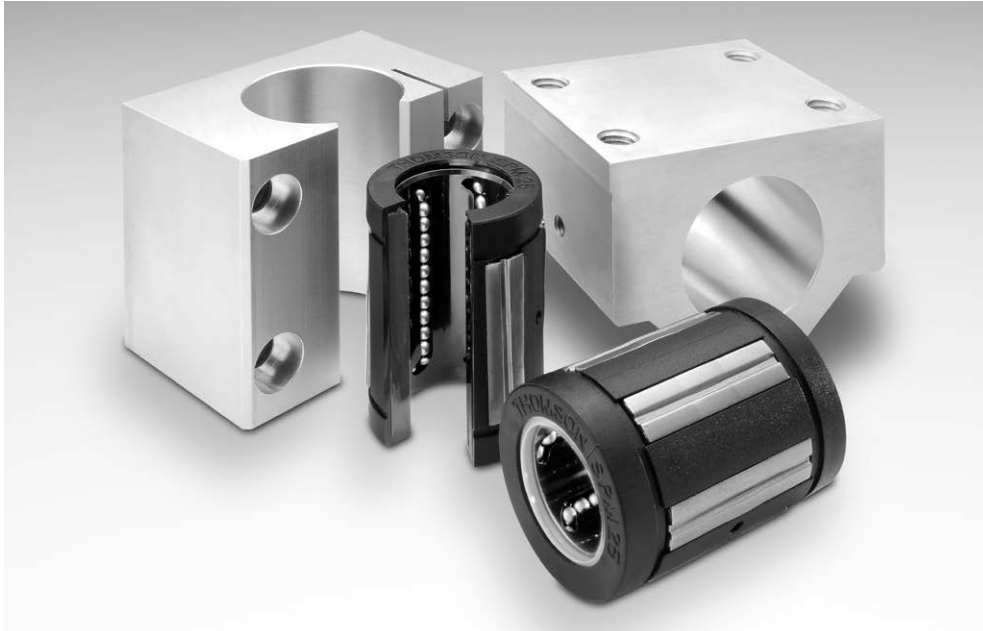

High performance from superior design:

- A coefficient of friction as low as 0,001. This allows the use of smaller less expensive motors, belts, gears and ball screws, when replacing high friction, plain bearings.
- A self-aligning capability up to 0,5° compensates for inaccuracies in base flatness or carriage machining. Achieved with Thomson Super Bearing plates which have defined radius crowns for maximized self-alignment accuracy.
- Accelerations as high as 150 m/s² and steady state travel speeds up to 3 m/s without the derating factors commonly required with linear guides.
- Double lip integral wipers that keep out dirt while retaining lubrication. Travel life is maximized.
- Light weight, wear-resistant, engineered polymer retainers and outer sleeves that reduce inertia and noise.
- Adjustable, closed and open configurations.

Quick to ship, drop-in replacement parts for existing applications:

- Dimensional interchangeable with competitive and legacy applications.
- Easy to order with local manufacturer's stock available in Europe and North America.
- Plus worldwide availability from over 1800 authorized distributors.

Genuine Thomson Quality:

- Thomson Ball Bushing Bearings in combination with 60 Case* shafting last longer and carry significantly more load than conventional linear bearings, allowing you to reduce component size, saving space and cost. Thomson is the one and only name you'll need when choosing a round rail solution.
- To complete your application with genuine Thomson 60 Case shafting and shaft supports, please visit www.thomsonlinear.com
- Thomson is the innovator of linear bearings and has supplied superior quality product to the linear industry for 60 years. Superior Thomson quality translates into better reliability and performance.

Metric – Super Ball Bushing* Bearings

Part Number Description and Specification

Super Smart Ball Bushing Bearings

SPM160PNWW-CR

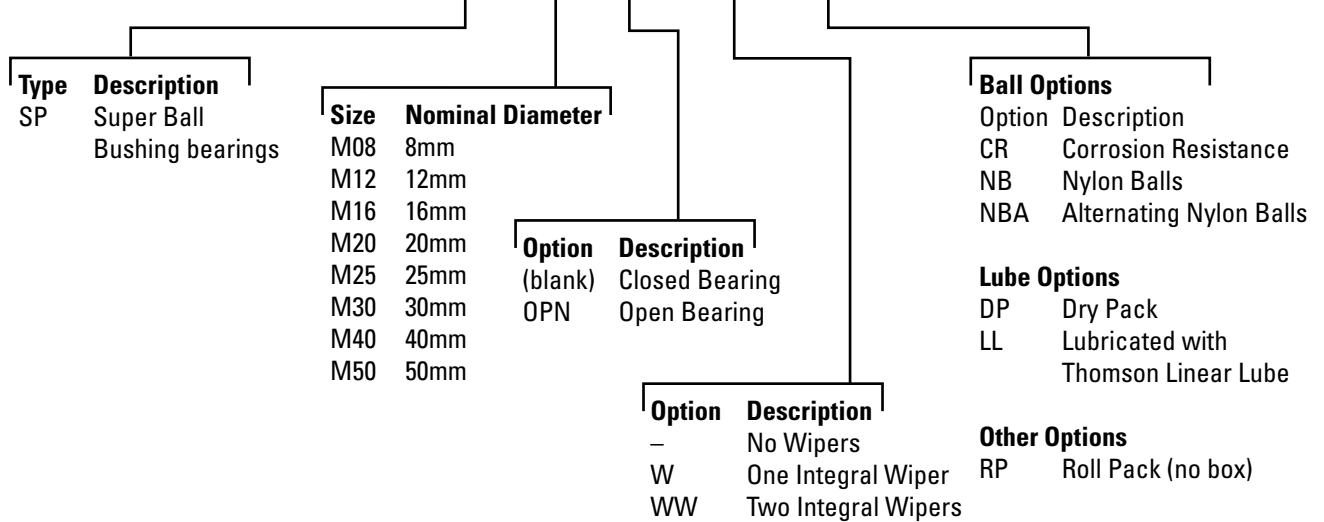

Super Smart Ball Bushing Pillow Blocks

SPPBAM16-CR

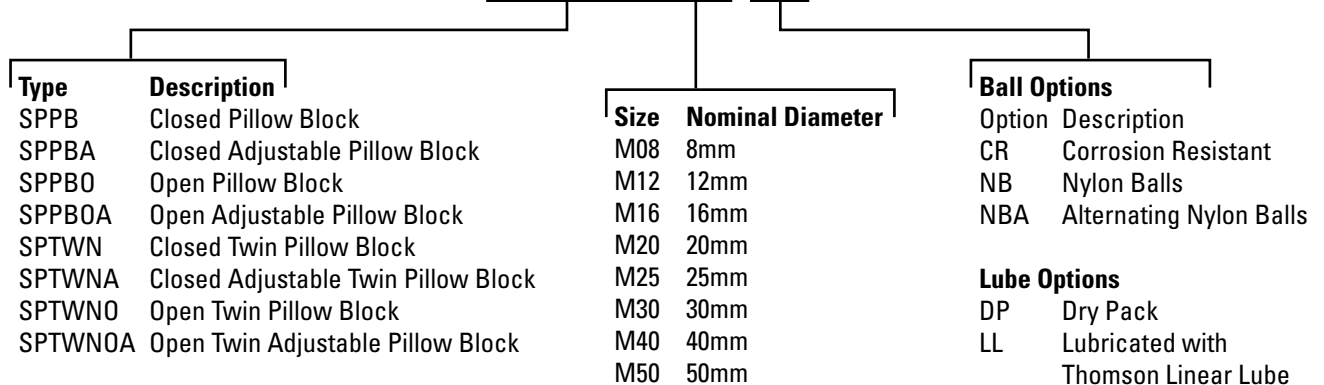

For addition informaiton on bearing options see page 273.

Metric – Super Ball Bushing Bearings

Super Ball Bushing Bearings (Closed Type) for End Supported Applications

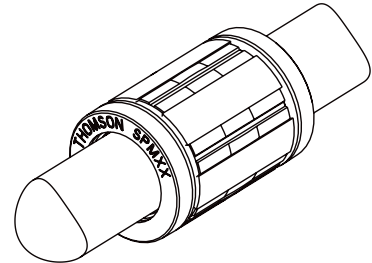
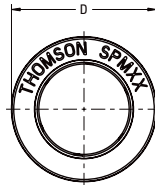
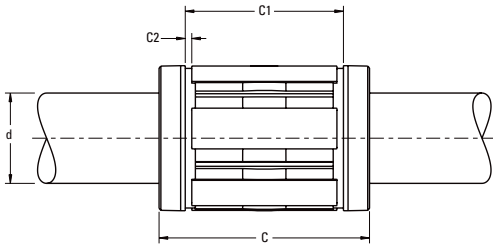

Super Metric Ball Bushing Bearings (Closed Type)

Part Number			Dimensions (mm)					Number of ball tracks	Mass (kg)	Dynamic Load $W^{(1)}$ (3) (N)	Load Limit $W_0^{(2)}$ (3) (N)
Without Integral Wipers	With One Integral Wiper	With Two Integral Wipers	$\phi d^{(4)}$	ϕD	C h14	C1 h13	C2 min				
SPM 08	SPM 08 W	SPM 08 WW	8	16	25	16.2	1.10	4	0.02	310	340
SPM 12	SPM 12 W	SPM 12 WW	12	22	32	22.6	1.30	5	0.02	830	910
SPM 16	SPM 16 W	SPM 16 WW	16	26	36	24.6	1.30	5	0.03	1020	1120
SPM 20	SPM 20 W	SPM 20 WW	20	32	45	31.2	1.60	6	0.06	2020	2220
SPM 25	SPM 25 W	SPM 25 WW	25	40	58	43.7	1.85	6	0.13	3950	4350
SPM 30	SPM 30 W	SPM 30 WW	30	47	68	51.7	1.85	6	0.19	4800	5280
SPM 40	SPM 40 W	SPM 40 WW	40	62	80	60.3	2.15	6	0.36	8240	9060
SPM 50	SPM 50 W	SPM 50 WW	50	75	100	77.3	2.65	6	0.66	12060	13270

(1) For rated travel life of 100 km. For longer travel lives, reduce load to $W \cdot (100/L)^{0.33}$ where L (km) is the required travel life. Do not exceed the Dynamic Load Rating for travel life of less than 100 km.

(2) The Load Limit is the maximum load that may be applied to a bearing and shaft. It is important to analyze the application so that peak and/or shock loads do not exceed the Load Limit.

(3) The load capacities W and W_0 are valid for a resultant load applied at 90° with the ball tracks oriented as shown in the polar graphs below. If the resultant acts along another direction, the appropriate multiplicative correction factor K_θ , should be applied to W and W_0 respectively.

(4) Internal bearing diameter is affected by the housing bore, see Table 1.

NOTE: External seals and retaining rings are available. See page 167 for specifications.

NOTE: For additional technical information, see the Engineering section beginning on page 262.

NOTE: For a corrosion resistant bearing add suffix-CR to the part number and reduce the load capacity by 30%.

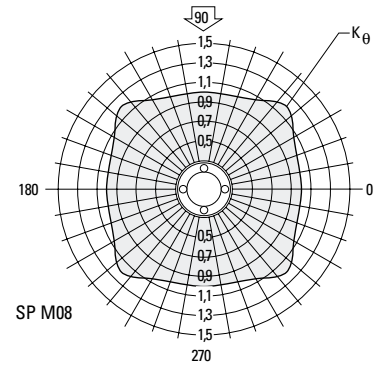
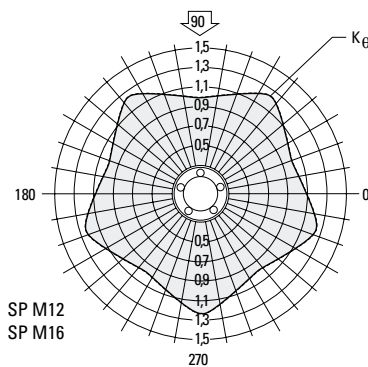
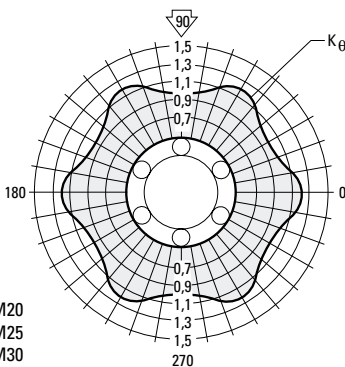

Metric – Super Ball Bushing* Bearings

Super Ball Bushing Bearings (Open Type) for Continuously Supported Applications

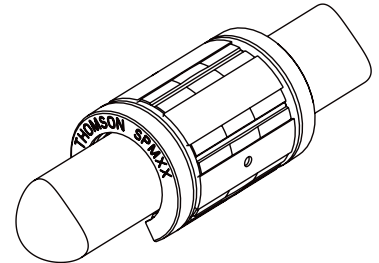
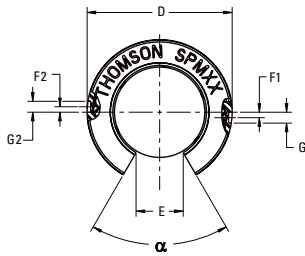
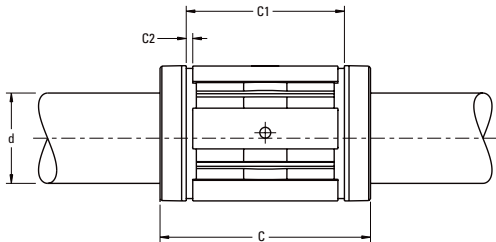

Super Metric Ball Bushing Bearings (Open Type)

Part Number			Dimensions (mm)											Angle α (deg)	Number of ball tracks	Mass (kg)	Dynamic Load $W^{(1)(3)}$ (N)	Load Limit $W_0^{(2)(3)}$ (N)
Without Integral Wipers	With One Integral Wiper	With Two Integral Wipers	$\phi d^{(4)}$	ϕD	C h14	C1 h13	C2 min	E +/- 0,1	F1	$\phi G1$	F2	$\phi G2$						
SPM 12 OPN	SPM 12 OPN W	SPM 12 OPN WW	12	22	32	22,3	1,30	7,0	1,35 (5)	3,0	-	-	70	4	0,02	1060	1170	
SPM 16 OPN	SPM 16 OPN W	SPM 16 OPN WW	16	26	36	24,6	1,30	9,8	0	3,0	-	-	70	4	0,02	1280	1410	
SPM 20 OPN	SPM 20 OPN W	SPM 20 OPN WW	20	32	45	31,2	1,60	10,5	0	3,0	-	-	58	5	0,05	2100	2310	
SPM 25 OPN	SPM 25 OPN W	SPM 25 OPN WW	25	40	58	43,7	1,85	13,0	1,50	3,0	0	3,5	60	5	0,10	4130	4540	
SPM 30 OPN	SPM 30 OPN W	SPM 30 OPN WW	30	47	68	51,7	1,85	15,3	0	3,5	2,0	3,0	60	5	0,15	5020	5520	
SPM 40 OPN	SPM 40 OPN W	SPM 40 OPN WW	40	62	80	60,3	2,15	21,4	0	3,5	1,5	3,0	58	5	0,30	8620	9480	
SPM 50 OPN	SPM 50 OPN W	SPM 50 OPN WW	50	75	100	77,3	2,65	24,0	0	4,5	2,5	5,0	55	5	0,55	12500	13750	

- (1) For rated travel life of 100 km. For longer travel lives, reduce load to $W \cdot (100/L)^{0.33}$ where L (km) is the required travel life. Do not exceed the Dynamic Load Rating for travel life of less than 100 km.
 - (2) The Load Limit is the maximum load that may be applied to a bearing and shaft. It is important to analyze the application so that peak and/or shock loads do not exceed the Load Limit.
 - (3) The load capacities W and W_0 are valid for a resultant load applied at 90° with the ball tracks oriented as shown in the polar graphs below. If the resultant acts along another direction, the appropriate multiplicative correction factor K_θ , should be applied to W and W_0 respectively. Open type bearings have reduced load capacities when used in pull-off situations.
 - (4) Internal bearing diameter is affected by the housing bore, see Table 1.
 - (5) Hole for anti-rotation pin is above centerline.
- NOTE: External seals and retaining are available. See page 167 for specifications.
 NOTE: For additional technical information, see the Engineering section beginning on page 262.
 NOTE: For corrosion resistant bearing add suffix-CR to the part number and reduce the load capacity by 30%.

Table 1 - Standard Diametral Clearances

Nominal Shaft Diameter d (mm)	Nominal Housing Bore Diameter D (mm)	Diametral Clearance	
		Housing Bore H7 (µm)	Housing Bore H6 (µm)
12	22	+33 +4	+26 +3
16	26	+33 +4	+26 +3
20	32	+37 +6	+30 +4
25	40	+37 +6	+30 +4
30	47	+37 +6	+30 +4
40	62	+44 +7	+35 +5
50	75	+44 +7	+35 +5

For Super Metric Ball Bushing Bearings mounted in a housing and with LinearRace® shafts, h6 tolerance

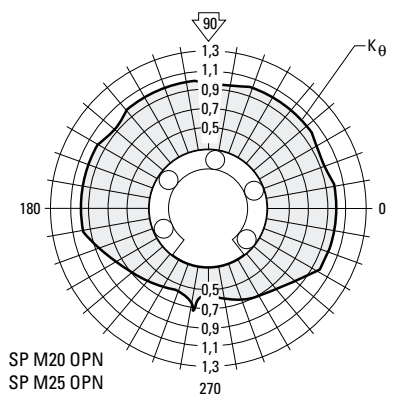
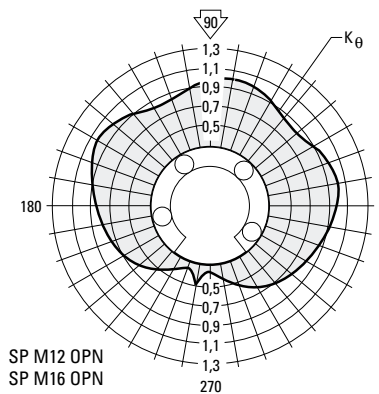

Metric – Super Pillow Blocks

Super Pillow Blocks

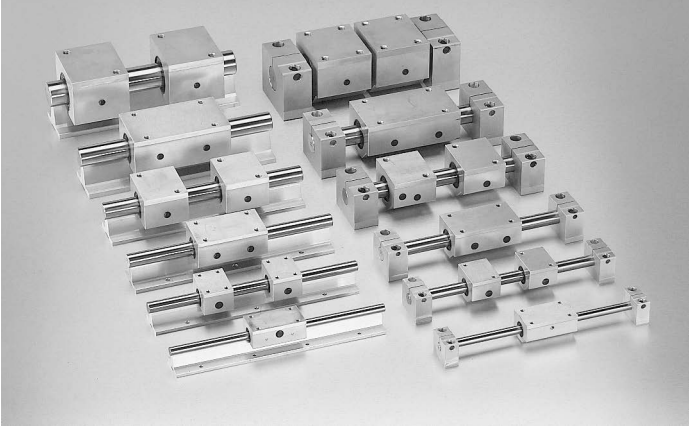

Thomson Pillow Blocks with factory-installed Super Metric Ball Bushing Bearings offer:

- Accelerations as high as 150 m/s² and steady state travel speeds up to 3 m/s without the derating factors commonly required with linear guides.
- Replaceable bearing components for quick, cost-effective machine maintenance and minimal downtime.
- Light weight, wear-resistant, engineered polymer retainers and outer sleeves that reduce inertia and noise.
- Standard, double-acting, integral seals at both ends which keep out dirt, grit and other contaminants, retain lubrication and maximize bearing life.
- Lubrication hole for easy maintenance.
- Tapped or thru hole mounting configuration for ease of installation.
- Twin version with two Super Ball Bushing Bearings providing twice the load capacity or 8 times more travel life than the single version.
- A single bearing version that self aligns in all directions, minimizing installation time and cost.

Note: See page 156 for information on Thomson Super Metric Ball Bushing Bearings.

Metric – Super Pillow Blocks

Super Pillow Blocks (Closed Type) for End Supported Applications

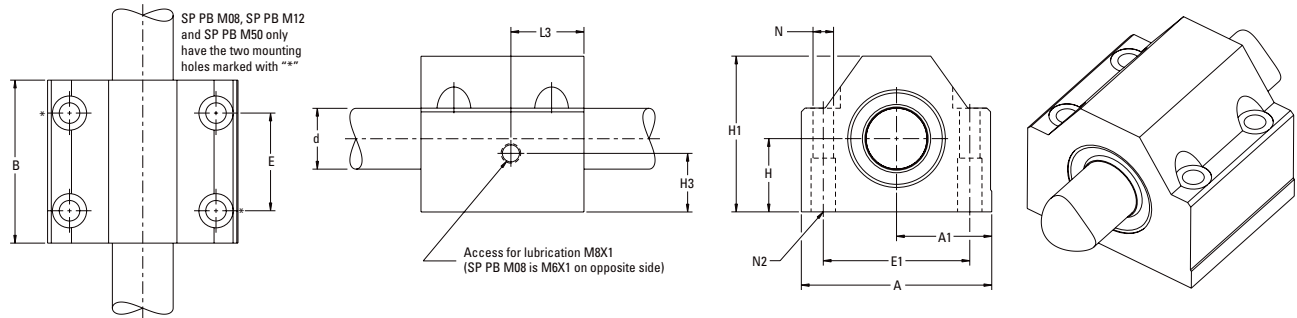

Super Pillow Blocks (Closed Type)

Part Number	Dimensions (mm)												Mass (kg)	Dynamic Load $W^{(1)(3)}$ (N)	Load Limit $W_0^{(2)(3)}$ (N)
	$\varnothing d^{(4)}$	H +/- 0,020	H1	A	A1 +/- 0,020	B	E +/- 0,1	E1 +/- 0,1	H3	L3 ⁽⁵⁾	$\varnothing N$	N2			
SP PB M08	8	15	28	35	17,5	32	20 ⁽⁶⁾	25 ⁽⁶⁾	12 ⁽⁵⁾	8,5	3,3	M4	0,07	310	340
SP PB M12	12	18	35	43	21,5	39	23 ⁽⁶⁾	32 ⁽⁶⁾	10	10,5	4,3	M5	0,13	830	910
SP PB M16	16	22	42	53	26,5	43	26	40	12	16,5	5,3	M6	0,21	1020	1120
SP PB M20	20	25	50	60	30,0	54	32	45	13	20,5	6,6	M8	0,35	2020	2220
SP PB M25	25	30	60	78	39,0	67	40	60	15	23	8,4	M10	0,66	3950	4350
SP PB M30	30	35	71	87	43,5	79	45	68	20	27	8,4	M10	0,97	4800	5280
SP PB M40	40	45	91	108	54,0	91	58	86	21,5	30	10,5	M12	1,81	8240	9060
SP PB M50	50	50	105	132	66,0	113	50 ⁽⁶⁾	108 ⁽⁶⁾	12,5	22	13,5	M16	3,00	12060	13270

- (1) For rated travel life of 100 km. For longer travel lives, reduce load to $W \cdot (100/L)^{0.33}$ where L (km) is the required travel life. Do not exceed the Dynamic Load Rating for travel life of less than 100 km.
- (2) The Load Limit is the maximum load that may be applied to a bearing and shaft. It is important to analyze the application so that peak and/or shock loads do not exceed the Load Limit.
- (3) The load capacities W and W_0 are valid for a resultant load applied at 90° with the ball tracks oriented as shown in the polar graphs below. If the resultant acts along another direction, the appropriate multiplicative correction factor K_θ , should be applied to W and W_0 respectively.
- (4) For bearing diametral clearances, see Table 2.
- (5) SP PB M08 lube hole is M6X1 tapped hole located on opposite side
- (6) SP PB M08, SP PB M12 and SP PB M50 pillow blocks have only 2 mounting holes. The mounting holes on these sizes are marked in the chart above with ""

Table 2 - Standard Diametral Clearances (Closed Type)

Nominal Size d (mm)	Diametral Clearance (µm)
8	+23 +2
12	+26 +3
16	+26 +3
20	+30 +4
25	+30 +4
30	+30 +4
40	+35 +5
50	+35 +5

For Pillow Blocks used with LinearRace Shaft, h6 tolerance

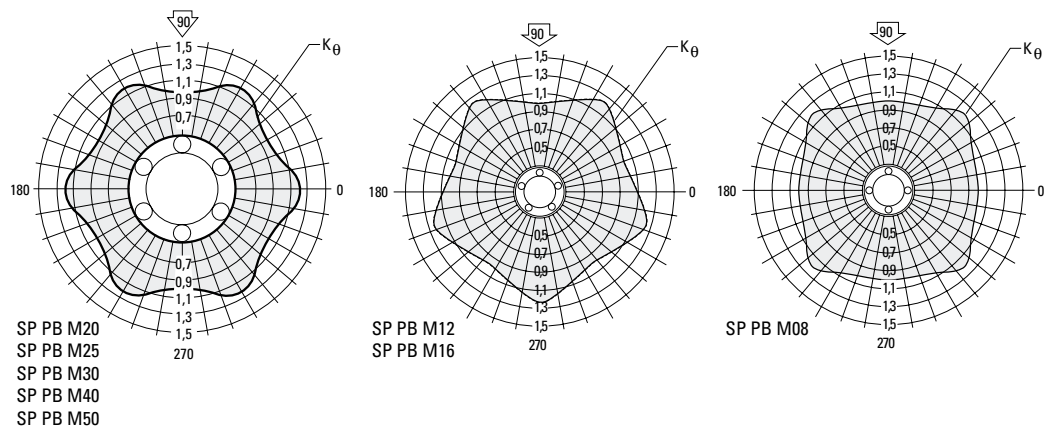

Metric – Super Pillow Blocks

Super Pillow Blocks (Closed Adjustable Type) for End Supported Applications

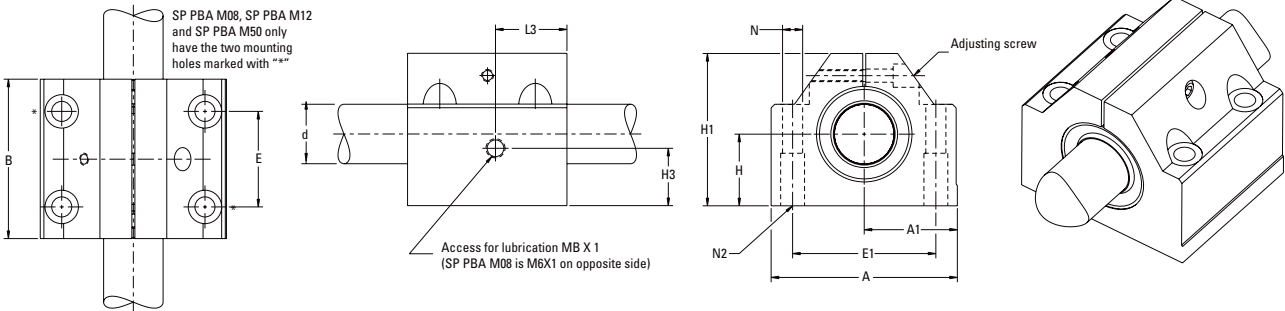

Super Pillow Blocks (Closed Adjustable Type)

Part Number	Dimensions (mm)												Mass (kg)	Dynamic Load $W^{(1)(3)}$ (N)	Load Limit $W_0^{(2)(3)}$ (N)
	$\varnothing d$	H +/- 0,020	H1	A	A1 +/- 0,020	B	E +/- 0,1	E1 +/- 0,1	H3	L3	$\varnothing N$	N2			
SP PBA M08	8	15	28	35	17,5	32	20 ⁽⁶⁾	25 ⁽⁶⁾	12 ⁽⁵⁾	8,5 ⁽⁵⁾	3,3	M4	0,07	310	340
SP PBA M12	12	18	35	43	21,5	39	23 ⁽⁶⁾	32 ⁽⁶⁾	10	10,5	4,3	M5	0,13	830	910
SP PBA M16	16	22	42	53	26,5	43	26	40	16	15,7	5,3	M6	0,21	1020	1120
SP PBA M20	20	25	50	60	30,0	54	32	45	13	20	6,6	M8	0,35	2020	2220
SP PBA M25	25	30	60	78	39,0	67	40	60	15	23	8,4	M10	0,66	3950	4350
SP PBA M30	30	35	71	87	43,5	79	45	68	16	26,5	8,4	M10	0,97	4800	5280
SP PBA M40	40	45	91	108	54,0	91	58	86	21,5	30	10,5	M12	1,81	8240	9060
SP PBA M50	50	50	105	132	66,0	113	50 ⁽⁶⁾	108 ⁽⁶⁾	12,5	22	13,5	M16	3,00	12060	13270

- (1) For rated travel life of 100 km. For longer travel lives, reduce load to $W \cdot (100/L)^{0,33}$ where L (km) is the required travel life. Do not exceed the Dynamic Load Rating for travel life of less than 100 km.
- (2) The Load Limit is the maximum load that may be applied to a bearing and shaft. It is important to analyze the application so that peak and/or shock loads do not exceed the Load Limit.
- (3) The load capacities W and W_0 are valid for a resultant load applied at 90° with the ball tracks oriented as shown in the polar graphs below. If the resultant acts along another direction, the appropriate multiplicative correction factor K_θ , should be applied to W and W_0 respectively.
- (4) For bearing diametral clearances, see Table 2.
- (5) SP PBA M08 lube hole is M6X1 tapped hole located on opposite side
- (6) SP PBA M08, SP PBA M12 and SP PBA M50 pillow blocks have only 2 mounting holes. The mounting holes on these sizes are marked in the chart above with "*"

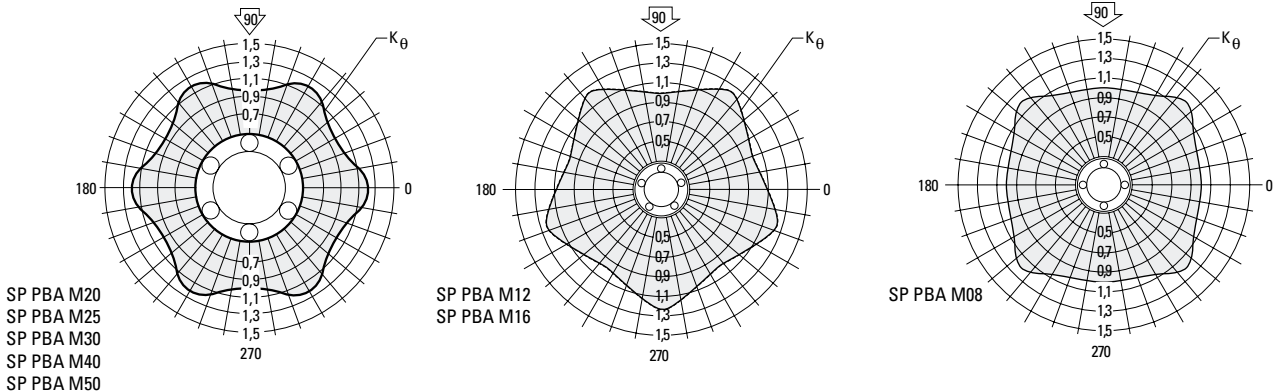

Metric – Super Pillow Blocks

Super Pillow Blocks (Open Type) for Continuously Supported Applications

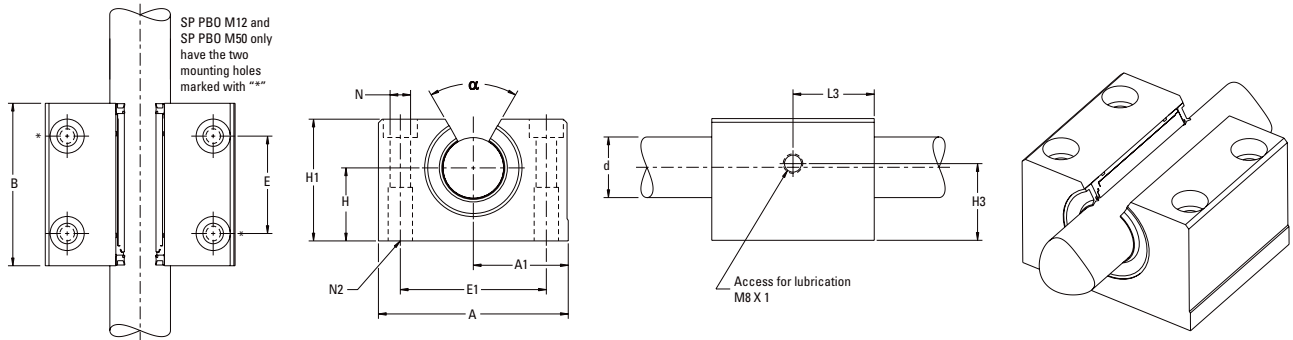

Super Pillow Blocks (Open Type)

Part Number	Dimensions (mm)												Angle α (deg)	Mass (kg)	Dynamic Load $W^{(1)(3)}$ (N)	Load Limit $W_0^{(2)(3)}$ (N)
	$\varnothing d^{(4)}$	H +/- 0,020	H1	A	A1 +/- 0,020	B	E +/- 0,1	E1 +/- 0,1	H3	L3	$\varnothing N$	N2				
SP PBO M12	12	18	35	43	21,5	39	23 ⁽⁶⁾	32 ⁽⁶⁾	10	10,5	4,3	M5	70	0,11	1060	1170
SP PBO M16	16	22	42	53	26,5	43	26	40	10,8	15,7	5,3	M6	58	0,19	1280	1410
SP PBO M20	20	25	50	60	30,0	54	32	45	13	20	6,6	M8	60	0,30	2100	2310
SP PBO M25	25	30	60	78	39,0	67	40	60	15	23	8,4	M10	60	0,60	4130	4540
SP PBO M30	30	35	71	87	43,5	79	45	68	20,5	27	8,4	M10	58	0,92	5020	5520
SP PBO M40	40	45	91	108	54,0	91	58	86	21,5	30	10,5	M12	55	1,65	8620	9480
SP PBO M50	50	50	113	132	66,0	113	50 ⁽⁶⁾	108 ⁽⁶⁾	12,5	22	13,5	M16	55	2,60	12500	13750

- (1) For rated travel life of 100 km. For longer travel lives, reduce load to $W \cdot (100/L)^{0,33}$ where L (km) is the required travel life. Do not exceed the Dynamic Load Rating for travel life of less than 100 km.
- (2) The Load Limit is the maximum load that may be applied to a bearing and shaft. It is important to analyze the application so that peak and/or shock loads do not exceed the Load Limit.
- (3) The load capacities W and W_0 are valid for a resultant load applied at 90° with the ball tracks oriented as shown in the polar graphs below. If the resultant acts along another direction, the appropriate multiplicative correction factor K_θ should be applied to W and W_0 respectively. Open type bearings have reduced load capacities when used in pull-off situations.
- (4) For bearing diametral clearances, see Table 3.
- (5) SP PBO M12 and SP PBO M50 pillow blocks have only 2 mounting holes. The mounting holes on these sizes are marked in the chart above with “**”

Table 3 - Standard Diametral Clearances (Open Type)

Nominal Size d (mm)	Diametral Clearance (μ m)
12	+26 +3
16	+26 +3
20	+30 +4
25	+30 +4
30	+30 +4
40	+35 +5
50	+35 +5

For Pillow Blocks used with Linear-Race Shaft, h6 tolerance

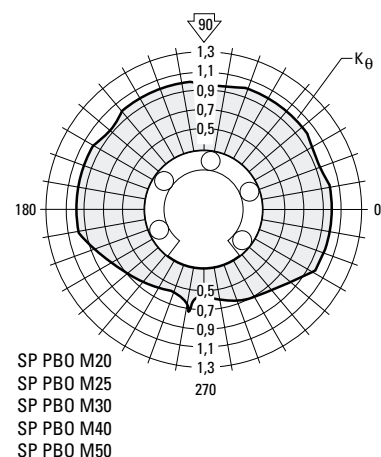
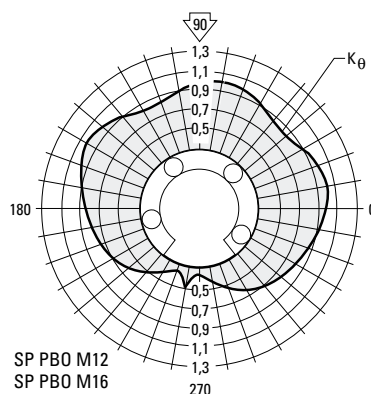

Metric – Super Pillow Blocks

Super Pillow Blocks (Open Adjustable Type) for Continuously Supported Applications

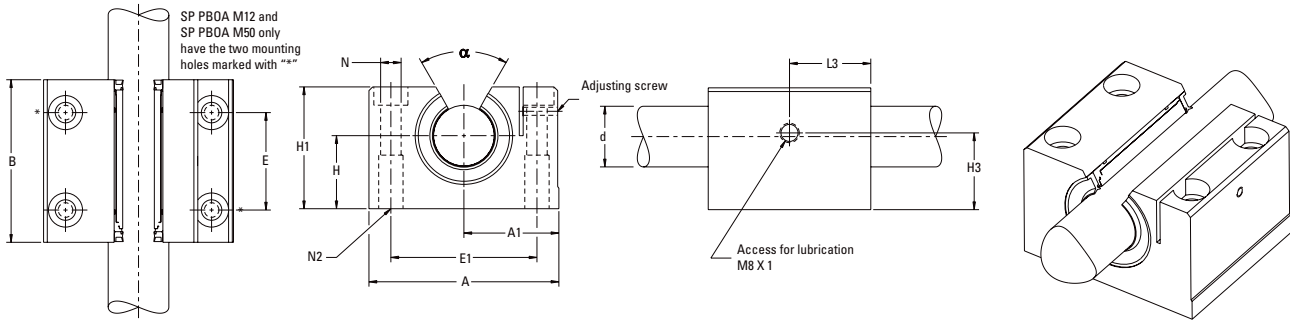

Super Pillow Blocks (Open Adjustable Type)

Part Number	Dimensions (mm)												Angle α (deg)	Mass (kg)	Dynamic Load $W^{(1)(3)}$ (N)	Load Limit $W_0^{(2)(3)}$ (N)
	$\varnothing d$	H +/- 0,020	H1	A	A1 +/- 0,020	B	E +/- 0,1	E1 +/- 0,1	H3	L3	$\varnothing N$	N2				
SP PBOA M12	12	18	35	43	21,5	39	23 ⁽⁴⁾	32 ⁽⁴⁾	10	10,5	4,3	M5	70	0,11	1060	1170
SP PBOA M16	16	22	42	53	26,5	43	26	40	10,8	15,7	5,3	M6	58	0,19	1280	1410
SP PBOA M20	20	25	50	60	30,0	54	32	45	13	20	6,6	M8	60	0,30	2100	2310
SP PBOA M25	25	30	60	78	39,0	67	40	60	15	23	8,4	M10	60	0,60	4130	4540
SP PBOA M30	30	35	71	87	43,5	79	45	68	20,5	27	8,4	M10	58	0,92	5020	5520
SP PBOA M40	40	45	91	108	54,0	91	58	86	21,5	30	10,5	M12	55	1,65	8620	9480
SP PBOA M50	50	50	113	132	66,0	113	50 ⁽⁴⁾	108 ⁽⁴⁾	12,5	22	13,5	M16	55	2,60	12500	13750

- (1) For rated travel life of 100 km. For longer travel lives, reduce load to $W \cdot (100/L)^{0.33}$ where L (km) is the required travel life. Do not exceed the Dynamic Load Rating for travel life of less than 100 km.
- (2) The Load Limit is the maximum load that may be applied to a bearing and shaft. It is important to analyze the application so that peak and/or shock loads do not exceed the Load Limit.
- (3) The load capacities W and W_0 are valid for a resultant load applied at 90° with the ball tracks oriented as shown in the polar graphs below. If the resultant acts along another direction, the appropriate multiplicative correction factor K_θ , should be applied to W and W_0 respectively. Open type bearings have reduced load capacities when used in pull-off situations.
- (4) SP PBOA M12 and SP PBOA M50 pillow blocks have only 2 mounting holes. The mounting holes on these sizes are marked in the chart above with “*”

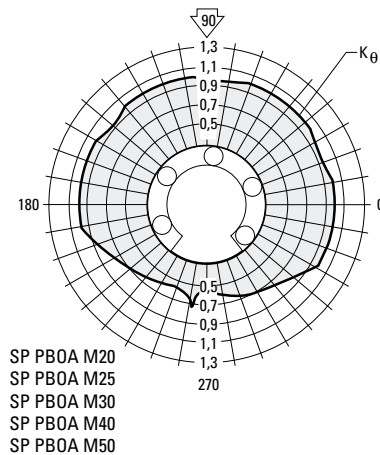
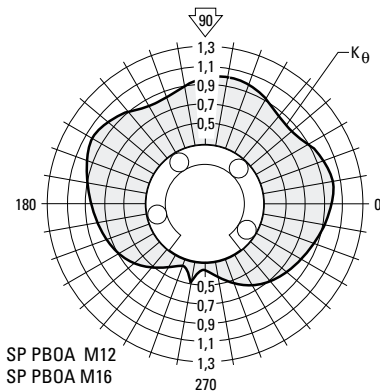

Metric – Super Pillow Blocks

Super Twin Pillow Blocks (Closed Type) for End Supported Applications

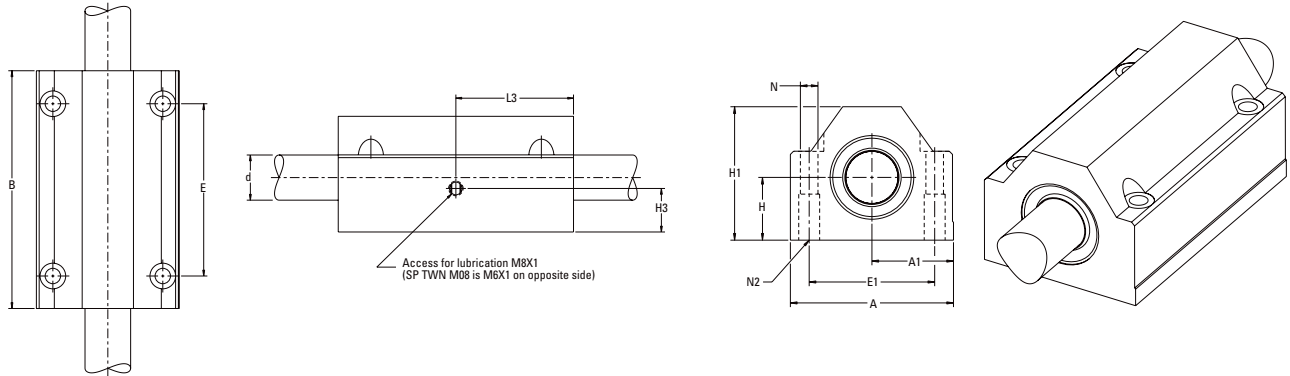

Part Number	Dimensions (mm)												Mass (kg)	Dynamic Load $W^{(1)(3)}$ (N)	Load Limit $W_0^{(2)(3)}$ (N)
	$\varnothing d^{(4)}$	H +/- 0,020	H1	A	A1 +/- 0,020	B	E +/- 0,1	E1 +/- 0,1	H3	L3	$\varnothing N$	N2			
SP TWN M08	8	15	28	35	17,5	62	50	25	12 ⁽⁵⁾	31 ⁽⁵⁾	3,3	M4	0,15	500	550
SP TWN M12	12	18	35	43	21,5	76	56	32	10	38	4,3	M5	0,27	1350	1490
SP TWN M16	16	22	42	53	26,5	84	64	40	16	42	5,3	M6	0,41	1660	1830
SP TWN M20	20	25	50	60	30,0	104	76	45	13	52	6,6	M8	0,66	3280	3610
SP TWN M25	25	30	60	78	39,0	130	94	60	15	65	8,4	M10	1,22	6410	7050
SP TWN M30	30	35	71	87	43,5	152	106	68	16	76	8,4	M10	1,90	7800	8580
SP TWN M40	40	45	91	108	54,0	176	124	86	21,5	88	10,5	M12	3,57	13380	14720
SP TWN M50	50	50	105	132	66,0	224	160	108	20	112	13,5	M16	6,30	19590	21550

(Closed Adjustable Type) for End Supported Applications

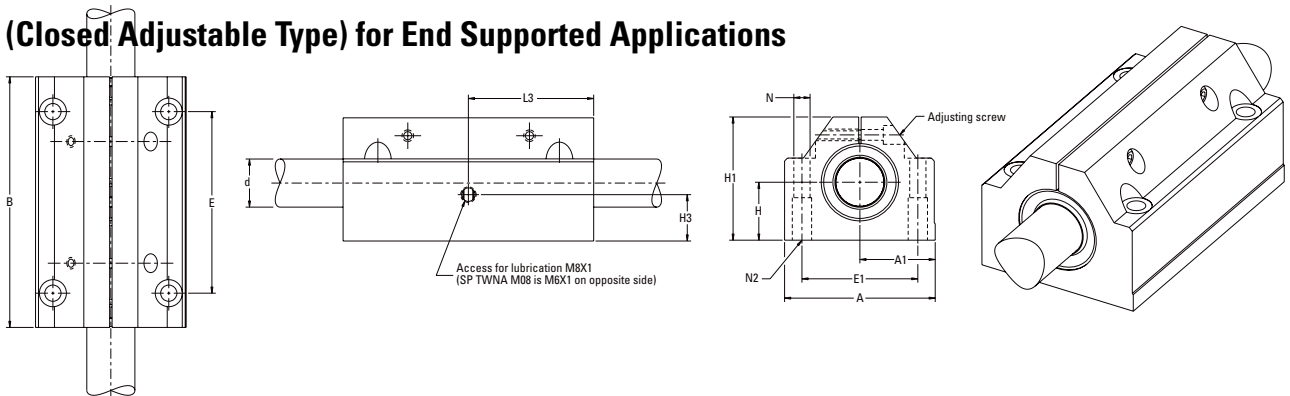

Part Number	Dimensions (mm)												Mass (kg)	Dynamic Load $W^{(1)(3)}$ (N)	Load Limit $W_0^{(2)(3)}$ (N)
	$\varnothing d$	H +/- 0,020	H1	A	A1 +/- 0,020	B	E +/- 0,1	E1 +/- 0,1	H3	L3	$\varnothing N$	N2			
SP TWNA M08	8	15	28	35	17.5	62	50	25	12 ⁽⁵⁾	31 ⁽⁵⁾	3,3	M4	0,15	500	550
SP TWNA M12	12	18	35	43	21.5	76	56	32	10	38	4,3	M5	0,27	1350	1490
SP TWNA M16	16	22	42	53	26.5	84	64	40	12	42	5,3	M6	0,41	1660	1830
SP TWNA M20	20	25	50	60	30.0	104	76	45	13	52	6,6	M8	0,66	3280	3610
SP TWNA M25	25	30	60	78	39.0	130	94	60	15	65	8,4	M10	1,22	6410	7050
SP TWNA M30	30	35	71	87	43.5	152	106	68	20	76	8,4	M10	1,90	7800	8580
SP TWNA M40	40	45	91	108	54.0	176	124	86	21,5	88	10,5	M12	3,57	13380	14720
SP TWNA M50	50	50	105	132	66.0	224	160	108	20	112	13,5	M16	6,30	19590	21550

See footnotes (1) (2) (3) (4) (5) (6) on page 162. For diametral clearances, see single versions of pillow block.

Metric – Super Pillow Blocks

Super Twin Pillow Blocks (Open Type) for Continuously Supported Applications

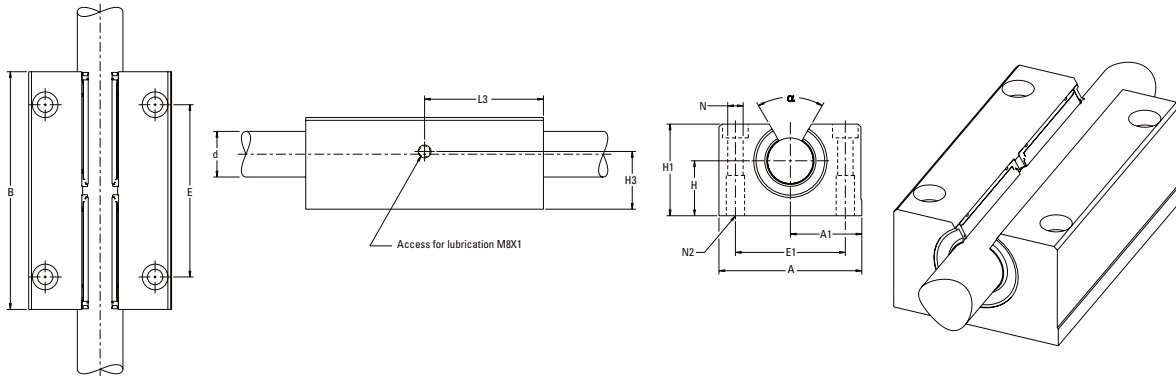

Part Number	Dimensions (mm)												Angle α (deg)	Mass (kg)	Dynamic Load $W^{(1)(3)}$ (N)	Load Limit $W_0^{(2)(3)}$ (N)
	$\varnothing d^{(4)}$	H +/- 0,020	H1	A	A1 +/- 0,020	B	E +/-0,1	E1 +/-0,1	H3	L3	$\varnothing N$	N2				
SP TWNO M12	12	18	28	43	21.5	76	56	32	10	38	4,3	M5	70	0,22	1350	1490
SP TWNO M16	16	22	35	53	26.5	84	64	40	18	42	5,3	M6	58	0,37	1660	1830
SP TWNO M20	20	25	41	60	30.0	104	76	45	16	52	6,6	M8	60	0,57	3280	3610
SP TWNO M25	25	30	50	78	39.0	130	94	60	15	65	8,4	M10	60	1,15	6410	7050
SP TWNO M30	30	35	60	87	43.5	152	106	68	16	76	8,4	M10	58	1,76	7800	8580
SP TWNO M40	40	45	77	108	54.0	176	124	86	21,5	88	10,5	M12	55	3,22	13380	14720
SP TWNO M50	50	50	88	132	66.0	224	160	108	20	112	13,5	M16	55	5,50	19590	21550

(Open Adjustable Type) for Continuously Supported Applications

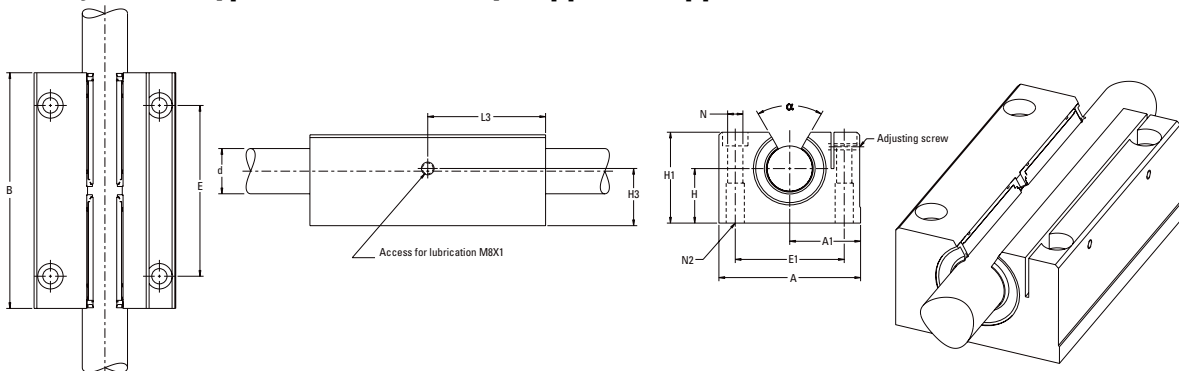

Part Number	Dimensions (mm)												Angle α (deg)	Mass (kg)	Dynamic Load $W^{(1)(3)}$ (N)	Load Limit $W_0^{(2)(3)}$ (N)
	$\varnothing d$	H +/- 0,020	H1	A	A1 +/- 0,020	B	E +/-0,1	E1 +/-0,1	H3	L3	$\varnothing N$	N2				
SP TWNOA M12	12	18	28	43	21.5	76	56	32	10	38	4,3	M5	70	0,22	1350	1490
SP TWNOA M16	16	22	35	53	26.5	84	64	40	18	42	5,3	M6	58	0,37	1660	1830
SP TWNOA M20	20	25	41	60	30.0	104	76	45	16	52	6,6	M8	60	0,57	3280	3610
SP TWNOA M25	25	30	50	78	39.0	130	94	60	15	65	8,4	M10	60	1,15	6410	7050
SP TWNOA M30	30	35	60	87	43.5	152	106	68	16	76	8,4	M10	58	1,76	7800	8580
SP TWNOA M40	40	45	77	108	54.0	176	124	86	21,5	88	10,5	M12	55	3,22	13380	14720
SP TWNOA M50	50	50	88	132	66.0	224	160	108	20	112	13,5	M16	55	5,50	19590	21550

See footnotes (1) (2) (3) (4) on page 163. For diametral clearances, see single versions of pillow block.

Accessories



Described here are accessories for Linear Ball Bushing Bearings and pillow blocks including retaining rings, external seals, integral seals and resilient mounts.

Metric – Accessories

Retaining Rings

Internal Retaining Rings

Push-in internal retaining rings, as shown, are for use with metric Ball Bushing bearings. Each retaining ring is installed inside the housing bore at each end of the bearing.

(Dimensions in mm)

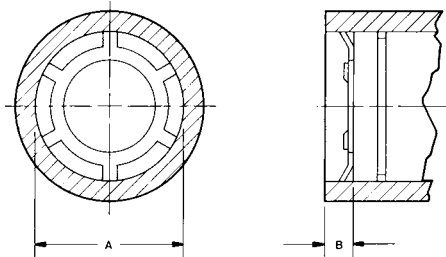

Part Number	Use with Ball Bushing Bearing Number	Nominal Shaft Diameter	Nominal Housing Bore A	Minimum End Space required B
PR M08	SP M08 or MA M08	8	16	1,5
PR M12	SP M12 or MA M12	12	22	2,0
PR M16	SSE M16 or MA M16	16	26	2,0
PR M20	SSE M20 or MA M20	20	32	2,0
PR M25	SSE M25 or MA M25	25	40	2,0
PR M30	SSE M30 or MA M30	30	47	2,0
PR M40	SSE M40 or MA M40	40	62	2,5
PR J16	SSJ M16	16	28	2,0
PR J20	SSJ M20	20	32	2,0
PR J25	SSJ M25	25	40	2,0
PR J30	SSJ M30	30	45	2,0
PR J40	SSJ M40	40	60	2,5

External Retaining Rings

External retaining rings are used to form one or two shoulders on the O.D. of the metric Ball Bushing bearings.

(Dimensions in mm)

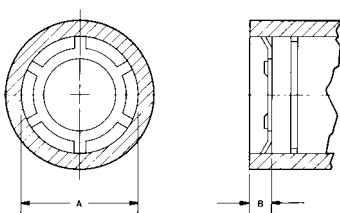

Part Number	Use with Ball Bushing Bearing Number	Nominal Shaft Diameter	T	Free Diameter D
WR M08	SP M08 or MA M08	8	1,00	14,7
WR M12	SP M12 or MA M12	12	1,20	20,5
WR M16	SSE M16 or MA M16	16	1,20	24,2
WR M20	SSE M20 or MA M20	20	1,50	29,6
WR M25	SSE M25 or MA M25	25	1,75	36,5
WR M30	SSE M30 or MA M30	30	1,75	43,5
WR M40	SSE M40 or MA M40	40	2,00	57,8
WR J16	SSJ M16	16	1,50	27,0
WR J20	SSJ M20	20	1,50	30,0
WR J25	SSJ M25	25	1,75	38,0
WR J30	SSJ M30	30	1,75	43,0
WR J40	SSJ M40	40	2,00	57,0

Metric – Accessories

External Seals

External Seals for Closed Metric Ball Bushing Bearings

Double-acting seals for use in fixed diameter housings.

(Dimensions in mm)

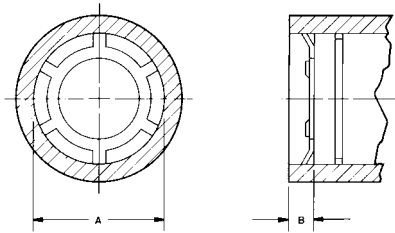

Part Number	Use with Ball Bushing Bearing Number	Nominal Shaft Diameter	T	Nominal (1) Housing Diameter D
SM 08	SP M08 or MA M08	8	3,0	16
SM 12	SP M12 or MA M12	12	3,0	22
SM 16	SSE M16 or MA M16	16	3,0	26
SM 20	SSE M20 or MA M20	20	4,0	32
SM 25	SSE M25 or MA M25	25	4,0	40
SM 30	SSE M30 or MA M30	30	5,0	47
SM 40	SSE M40 or MA M40	40	5,0	62

External Seals for Adjustable Metric Ball Bushing Bearings

Double-acting seals for use in adjustable diameter housings. Series ADJ seals have a radial slot through the circumference to facilitate diameter adjustment.

(Dimensions in mm)

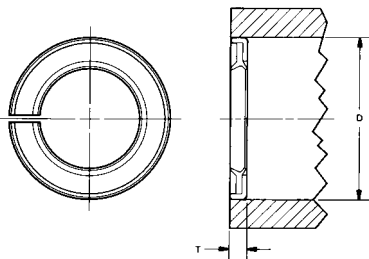

Part Number	Use with Ball Bushing Bearing Number	Nominal Shaft Diameter	T	Nominal (1) Housing Diameter D
SM 08 ADJ	SP M08 or MA M08	8	3,0	16
SM 12 ADJ	SP M12 or MA M12	12	3,0	22
SM 16 ADJ	SSE M16 or MA M16	16	3,0	26
SM 20 ADJ	SSE M20 or MA M20	20	4,0	32
SM 25 ADJ	SSE M25 or MA M25	25	4,0	40
SM 30 ADJ	SSE M30 or MA M30	30	5,0	47
SM 40 ADJ	SSE M40 or MA M40	40	5,0	62

External Seals for Open Metric Ball Bushing Bearings

Double-acting seals for use in open type housings.

(Dimensions in mm)

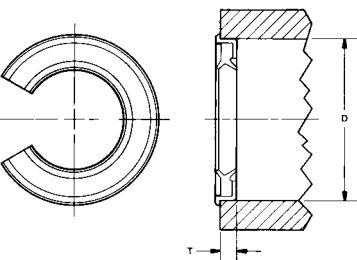

Part Number	Use with Ball Bushing Bearing Number	Nominal Shaft Diameter	T	Free Diameter D
SM 12 OPN	SP M12 or MA M12	12	3,20	22
SM 16 OPN	SSE M16 or MA M16	16	3,20	26
SM 20 OPN	SSE M20 or MA M20	20	4,20	32
SM 25 OPN	SSE M25 or MA M25	25	4,20	40
SM 30 OPN	SSE M30 or MA M30	30	5,15	47
SM 40 OPN	SSE M40 or MA M40	40	5,15	62

(1) For use in tolerance zones up to H7.

60 Case Shafting

60 Case Shafting



60 Case Shafting	170 - 225
60 Case Product Overview	173 - 177
Inch 60 Case Shafting	178 - 192
Support Rails and Support Rail	
Assemblies	186 - 189
Support Block	190 - 192
Metric 60 Case Shafting	193 - 199
Support Rails and Support Rail	
Assemblies	196 - 198
Support Block	199
Quick Shaft	200 - 203
Special Machining	204 - 225

Standard 60 Case Shaft Size and Availability Chart

Material	Carbon Steel										440 C Stainless Steel				52100 Tubular		316 SS	Aluminum		
	60 min.										50 min.			55 min.	58 min.		20-25	70		
Tolerance Class	L				S		N		D	XL	G	L	S	G	Instrument	L	S	L	AL	
Optional Features	L	DC	PD	CPPE	PD	S	DC	N				L	PD							
1/8"																				
3/16"	•																			
1/4"	•					•		•			•	•		•	•					•
3/8"	•					•		•			•	•		•	•					•
1/2"	•		•	•	•	•		•			•	•	•	•	•					•
5/8"	•		•	•	•	•		•			•	•	•	•	•					•
3/4"	•	•	•	•	•	•	•	•			•	•	•	•	•		•	•	•	•
7/8"	•	•						•	•											
1"	•	•	•	•	•	•	•	•	•		•	•	•	•	•		•	•	•	•
1 1/8"	•	•						•	•											
1 1/4"	•	•	•	•	•	•	•	•	•			•	•	•						•
1 3/8"	•								•											
1 1/2"	•	•	•	•	•	•	•	•	•			•	•	•			•	•	•	
1 5/8"	•								•											
1 3/4"	•	•						•	•											
2"	•	•	•	•	•	•	•	•	•	•			•	•	•					•
2 1/4"	•	•						•	•	•										
2 1/2"	•	•						•	•	•			•	•			•	•		
3"	•	•						•	•	•							•	•		
3 1/2"	•	•																		
4"	•							•				•					•	•		
Catalog Page	179	181	180	180	180	179	181	179	179	179	179	182	182	182	183	183	183	183	184	185

Material	Carbon Steel			440 C SS
	60 min.			50 min.
Tolerance Class	MM (ISO h6)			MM (ISO h6)
Optional Features	MM	T1	T2	
5 mm	•			•
8 mm	•			•
10 mm	•			•
12 mm	•	•	•	•
15 mm	•			•
16 mm	•	•	•	•
20 mm	•	•	•	•
25 mm	•	•	•	•
30 mm	•	•	•	•
40 mm	•	•	•	•
50 mm	•			•
60 mm	•			•
80 mm	•			•
Catalog Page	193	194	194	195

Thomson 60 Case shafting is sold as cut-to-length (CTL), random length (RL), special machined (SM), and as quick shaft (QS).

Since Thomson grinds and hardens all of its own shafting, diameters and tolerances not listed are available as special grind and are made to order. Minimum lots may apply.

Tolerance Classes:

- L - For use with XA, Open and Adjustable Ball Bushing Bearings and Pillow Blocks as well as Super Ball Bushing Bearings and Super Smart Ball Bushing Bearings
- S - For use with A type ball bushings
- N - For use with needle roller Bearings
- D - For use with Thomson Die Set Ball Bushing Bearings
- G - Ball Grooved for use with Thomson Super Ball bushing
- XL - For use with XR bearing (Carbon Steel)

Optional Features:

- PD - Predrilled
- CPPE - Chrome Plated Plain Ends
- DC - Deep Case

Inch 60 Case Shafting

Standard Support Rail Size and Availability Chart

Type	SR	SR-PD	SRA	SRA-SS	SRA-TU	LSR	LSR-PD	LSRA	LSRA-CR	XSR	XSRA
Description	Aluminum Support Rail	Aluminum Support Rail with Predrilled Holes	Aluminum Support Rail Carbon Steel Shaft	Aluminum Support Rail Assembly 440C SS Shaft	Aluminum Support Rail 51200 Tubular Shaft	Steel Lower Support Rail	Steel Lower Support Rail with Predrilled Holes	Steel Lower Support Rail Assembly Carbon Steel Shaft	Corrosion Resistant Steel Lower Support Rail Assembly 440C SS Shaft	Extra Rigid Cast Steel Support Rail	Extra Rigid Cast Steel Support Rail Assembly
1/2"	•	•	•	•		•	•				
5/8"	•	•	•	•		•	•	•	•		
3/4"	•	•	•	•	•	•	•	•	•		
1"	•	•	•	•	•	•	•	•	•		
1 1/4"	•	•	•	•		•	•	•	•		
1 1/2"	•	•	•	•	•	•	•	•	•		
2"	•	•	•	•	•	•	•			•	•
2 1/2"						•	•				
3"						•	•			•	•
4"						•	•				
Catalog Page	188	188	189	189	189	188	188	189	189	188	189

Standard Support Rail Assembly Size and Availability Chart

Type	SRM	SRM T1	SRM T2	SRAM T1	SRAM T2	LSRM	LSRM T1	LSRM T2	LSRA M	LSRA M CR
Description		Steel Lower Support Rail Assembly Carbon Steel Shaft	Steel Lower Support Rail with Predrilled Holes T2 Hole Pattern	Aluminum Support Rail Assembly with Predrilled Holes T1 Hole Pattern	Aluminum Support Rail Assembly with Predrilled Holes T2 Hole Pattern	Steel Lower Support Rail	Steel Lower Support Rail with Predrilled Holes T1 Hole Pattern	Steel Lower Support Rail with Predrilled Holes T2 Hole Pattern	Steel Lower Support Rail Assembly Carbon Steel Shaft	Corrosion Resistant Steel
12mm	•	•	•	•	•	•	•	•		
16mm	•	•	•	•	•	•	•	•	•	•
20mm	•	•	•	•	•	• ¹	• ¹	• ¹	• ¹	• ¹
25mm	•	•	•	•	•	•	•	•	•	•
30mm	•	•	•	•	•	•	•	•	•	•
40mm	•	•	•	•	•	• ¹	• ¹	• ¹	• ¹	• ¹
Catalog Page	198	198	198	198	198	198	198	198	198	198

Standard Support Block Size and Availability Chart

Type	ASB	FSB	SB	WM	Type	ASBM	SBM
Description	Aluminum Support Block	Flanged Aluminum Support Block	Steel Support Block	Waymount Support	Description	Aluminum Support Block	Steel Support Block
1/4"	•		•		8mm	•	•
3/8"	•		•		12mm	•	•
1/2"	•	•	•	•	16mm	•	•
5/8"			•		20mm	•	•
3/4"	•	•	•		25mm	•	•
1"	•	•	•	•	30mm	•	•
1 1/4"		•	•		40mm	•	•
1 1/2"	•		•		Catalog Page	199	199
2"				•			
3"				•			
4"				•			
Catalog Page	191	192	191	192			

¹ Not all sizes are stocked, minimum order quantities may apply.

60 Case Product Overview

For over 50 years Thomson has been producing Precision Linear Shafting for the Thomson Linear Ball Bushing and various other applications.

- We are one of a few Linear Motion component suppliers producing their own shafting.
- We offer the largest selection of linear shafting, not just the popular sizes.
- We offer a complete Linear Motion solution not just one component of a linear system.
- We offer the widest range of inch and metric shafting, support rails and support blocks in the market today.
- We continually optimize our processes to ensure optimal bearing performance and extended life.
- We perform thousands of hours of laboratory testing per year to continually evaluate our products.

While shafts may appear the same to the untrained eye on the surface, there are significant performance differences due to the manufacturer's selected standards and the manufacturing processes used to achieve them. Thomson 60 Case was developed and is continually enhanced because of our goal to provide a consistent finish, roundness, straightness, cylindricity case hardness and depth on all shafting for the demands of a linear bearing. Unlike common shafting, Thomson 60 Case shafting is manufactured to the highest quality standards in an ISO 9000:2000 registered facility. Our techniques have been continuously upgraded with proprietary knowledge gained from over 50 years of manufacturing experience. Using Thomson 60 Case with Thomson Ball Bushing bearings ensures optimal bearing performance and travel life.

Assortment

Thomson 60 Case is available from stock in Carbon Steel, 440 C Stainless Steel, 52100 Tubular, 316 Stainless Steel, Carbon Steel Chrome Plated, Carbon Steel Pre drilled, and 440 C Stainless Pre drilled from 3/16 to 4". Thomson 60 Case can be mounted or delivered pre-assembled, in three configurations: type SR standard support rails, type LSR low profile support rails and type XSR extra rigid support rails. Contact Thomson or review the catalog datasheets to see available diameters for the different materials. Thomson has the widest range of materials and diameters available on the market from one source.

Material



Thomson 60 Case carbon steel shafting is made of high quality specially developed alloy steel. When it comes to linear shafting no other manufacturers have set such high standards or specifications for the raw steel used in the production of linear shafting. The chemical properties of the steel are customized to provide consistent, homogenous microstructure and proper response to thermal processing. When you use Thomson 60 Case you can be confident you get consistent material from shaft to shaft.

Case Hardness

All Thomson 60 Case is induction hardened and the

hardness varies by material type. Thomson 60 Case carbon steel shaft is induction hardened to a 60 Rc min. The Thomson 440C "corrosion resistant" stainless steel shafting is hardened to a 50 Rc min. The 316 Thomson "corrosion proof" stainless steel is not hardened. The Thomson 52100 Tubular shafting is hardened to a 58 Rc min.

Case Depth

The case depth on all Thomson 60 Case Shafting is precisely controlled for consistent quality and optimal performance. The extremely hard surface minimizes wear when acting as an inner race of a linear bearing, is resistant to seal lip wear, nicks and scratches for your application needs. The Thomson 60 Case standard case depth is, in some cases, double competitor shafting. This deeper standard case depth provides a stronger, more consistent homogenous microstructure for a linear bearing to run on leading to an increase in shaft life. For special applications Thomson offers deep case in carbon steel, where the case depth is two times the normal depth. For specific case depths refer to catalog datasheets.

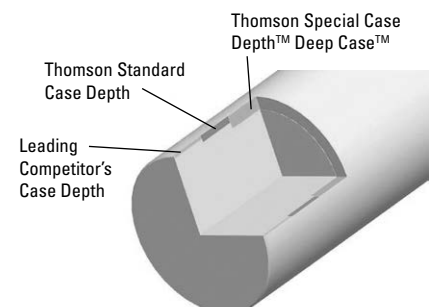

Introduction

Surface Finish

Surface is the key factor affecting travel life, load levels, frictional resistance, and smoothness of travel. Thomson 60 Case shafting is centerless ground for a consistent smooth and industry leading cataloged surface finish of 8 Ra max. Excellent surface finish and hardness maximize the efficiency and life of linear bearings, shaft riding seals, and overall visual appearance. When 8 Ra is not good enough we can provide 6 Ra surface finishes at an additional cost. Smoother equals longer bearing life.

Roundness

Shaft roundness is vital for linear race applications such as spindles and guide rods where accuracy, life or precision is paramount. Roundness ensures uniform distribution of bearing loads for maximized bearing life, longer travel life and improved positional accuracy. Shafts that look round can be deceiving to the eye and anything but round when properly evaluated, using precision tracing techniques. Thomson 60 Case shaft roundness is within 0.000080" for Class L, S, D, M and .000050" for Class N. Our leading competitors don't catalog roundness and some are .0002". Rounder equals longer bearing life.

These two graphs taken from a roundness trace display the major roundness difference between Thomson 60 Case LinearRace shafting products and competitor shafting.

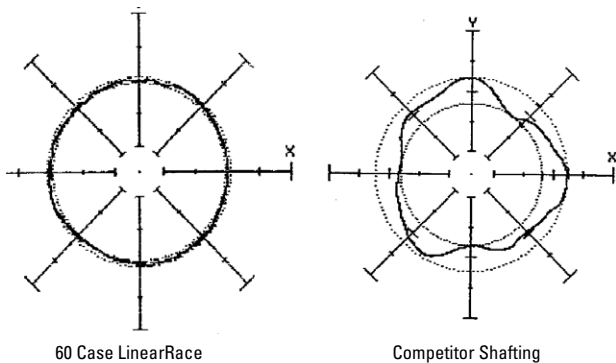

Straightness

Straightness is the most vital parameter to positioning accuracy for a linear ball bushing system. Thomson 60 Case shafts are straight within 0.001" per foot cumulative (TIR .002") when shipped from the factory. Handling or machining of shafting can cause the material to bend once they leave the factory. When straightness is critical let Thomson provide the special machined shaft; let us machine and straighten the shaft for you using our proprietary straightening and measurement techniques.

Our leading competitor does not catalog straightness. Straighter equals higher precision.

60 Case LinearRace shafting is inspected to ensure that it meets the highest quality standards. Standard straightness for all 60 Case LinearRace shafting is .001 inch per foot (.025mm/300mm) cumulative .002 inch (.05mm) TIR, with special straightness of .0005 inch per foot (.012 mm/300mm) cumulative .001 inch (.025mm) TIR

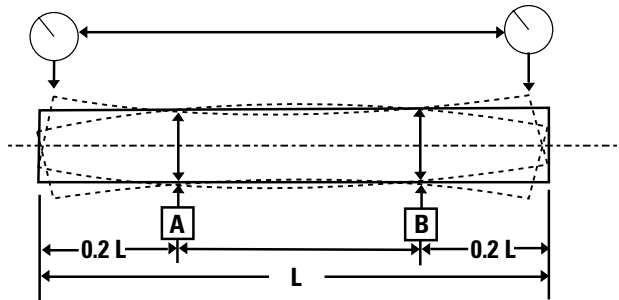

available.

Cylindricity

Cylindricity is a measure of the degree of conformance of the outside surface (diameter along the length of the shaft) to a true cylinder. True conformance (high cylindricity) ensures the benefits of roundness, diameter and straightness are present over the shaft length, or working surface, and not just in a particular location. This ensures uniform distribution of bearing loads, increases load capacity in the working area of the bearing, maximizes bearing life, and increases travel life. Taper is a component of cylindricity and all Thomson 60 Case shafts are produced with a maximum taper of 1/2 the diameter tolerance over the entire length of the shaft.

In linear bearing applications, taper found in competitor shafting can cause one portion of the linear bearing to be loaded higher than the other. This can cause dramatic reduction in travel life or load capacity. As

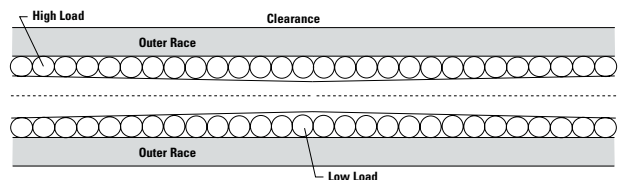

taper increases, balls go in and out of preload causing premature wear and reduction in travel life.

60 Case Product Overview (continued)

Length Tolerance

Thomson 60 Case shafting can be cut to your specified length. It will have a standard length tolerance of $\pm 1/32''$ for diameters less than 2 inches and $\pm 1/16''$ for all larger diameters. Special length tolerances are available for an additional charge. All cut shafting is subject to a deburring process to remove sharp edges. The size of the standard chamfer is approximately $1/32'' \times 45$ degrees for diameters less than 1" and $1/16'' \times 45$ degrees for diameters 1" and larger. Special chamfer sizes can be provided for an additional charge.



Predrilled and Tapped Holes

Thomson 60 Case shafting is stocked with radial holes drilled and tapped to accept a continuous shaft support rail in both carbon steel and 440 C stainless steel. Continuous support prevents shaft deflection when used to support heavy loads or for long travel lengths.

Special Coatings

Thomson offers a variety of corrosion resistant products to meet the needs of specific corrosive environments. Thomson 60 Case is available as thin dense chrome plated with plain ends from stock or 100% chrome plated, black oxide, or Armoloy™ plated to name a few. Contact our application engineering team or see page 206 for more information.

Precision Special Machining

Thomson 60 Case can be supplied specially machined to your drawing and or application requirements. Leave your special machining needs to us. With over 50 years of experience, we can provide a high quality special machined shaft to your specifications allowing you to focus on your core competency. Fax us a detailed sketch or drawing and let our engineers provide you with a quotation. See page 204 for a sample of machining offered.

How does Thomson 60 Case compare to our leading competitor shafting?

	Thomson	Competitor 1	Competitor 2
Materials	Carbon Steel	Carbon Steel	Carbon Steel
	440 C SS	440 C SS	440 C SS or equiv.
	316 SS		52100 Tubular
	52100 Tubular		
	Ultra Light Aluminum*		
Tolerance Classes	L, N, S, D, G, MM	L, S, MM	L, S, MM
Case Depth	.080"	.080"	.035"
Surface Finish	8 Ra Max	10-12 RMS	12 RMS
Roundness (L class)	.000080"	not cataloged	.0002"
Straightness	.001"/foot	.001-.002"/foot .0012"	not cataloged
Taper	.0001"	not cataloged	.0004"

* See page 182 for Aluminum specifications

60 Case LinearRace Shafting for End Supported Applications

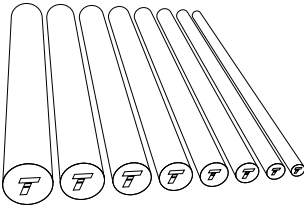

Solid 60 Case LinearRace Shafting Features:

- Diameter range between 3/16 and 4 inch.
- Roundness 80 millionths of an inch.
- Case hardness 60 HRC minimum.
- Surface finish 8 Ra microinch.
- Available in corrosion resistant 440C stainless steel (50 HRC minimum).
- Available with PrePlate* chrome option.
- Standard straightness is .001 inch per foot cumulative (.002 TIR) with special straightness at .0005 inch per foot cumulative (.001 TIR) available.

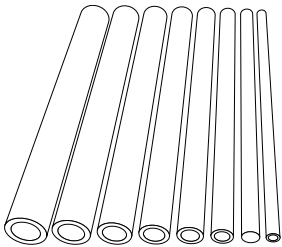

60 Case Tubular Lite* LinearRace Shafting Features:

- Hollow inner diameter reduces weight and inertia.
- Diameter range between 3/4 and 4 inch.
- Roundness 80 millionths of an inch.
- Case hardness 58 HRC minimum.
- Surface finish 8 Ra microinch.
- Standard straightness is .001 inch per foot cumulative (.002 TIR) with special straightness at .0005 inch per foot cumulative (.001 TIR) available.

60 Case LinearRace Shafting (PreDrilled) for Continuously Supported Applications

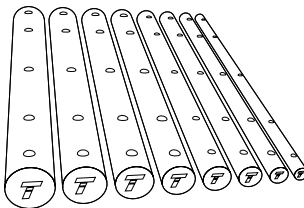

Solid 60 Case LinearRace Shafting with Mounting Holes Features:

- Radial drilled and tapped holes ready for immediate use with standard hole spacing to match standard 60 Case LinearRace support rails.
- Diameter range between 1/2 and 4 inches, special machining (SM) required over 2 inches.
- Surface finish 8 Ra microinch.
- Hardness 60 HRC minimum.
- Roundness 80 millionths of an inch.
- Available in corrosion resistant 440C stainless steel (50 HRC min).
- Available with Preplate chrome option.
- Standard straightness .001 inch per foot cumulative (.002 TIR) with special straightness at .0005 inch per foot cumulative (.001 TIR) available.

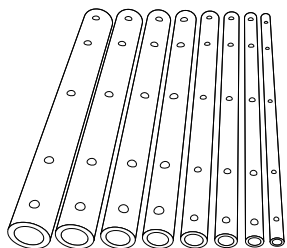

60 Case Tubular Lite LinearRace Shafting with Mounting Holes Features:

- Hollow design reduces weight and inertia.
- Can be supplied with radial drilled and tapped holes, ready for immediate use.
- Standard hole spacing to match standard 60 Case LinearRace support rails.
- Diameter range between 1 1/2 and 4 inch.
- Roundness 80 millionths of an inch.
- Case hardness 58 HRC minimum.
- Surface finish 8 Ra microinch.
- Standard straightness .001 inch per foot cumulative (.002 TIR) with special straightness at .0005 inch per foot cumulative (.001 TIR) available.

*Trademark of Thomson Industries Inc. Thomson Industries Inc. is registered in the U.S. Patent and Trademark Office and in other countries.

60 Case LinearRace Support Rails and Assemblies for Continuously Supported Applications

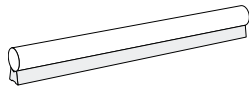

LSR Low Profile 60 Case LinearRace Support Rail Features:

- Diameter range between 1/2 and 4 inch.
- Available with standard mounting holes for immediate use.
- Available without mounting holes for custom hole spacing.
- Low Profile design.
- Unlimited travel lengths.

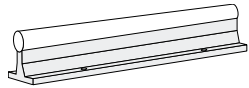

SR 60 Case LinearRace Support Rail and SRA 60 Case LinearRace Support Rail Assembly Features:

- Diameter range between 1/2 and 2 inch.
- Available with standard mounting holes for immediate use.
- Available without mounting holes for customized hole spacing.
- Available as a pre-engineered, ready to install assembly.
- Light weight, high strength aluminum alloy rail.
- Unlimited travel lengths.

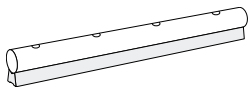

LSRA Smart Rail* Assembly Features:

- Diameter range between 5/8 and 1 1/2 inch.
- Bolt-down-from-the-top mounting.
- Single piece lengths up to 15 feet long.
- Low profile design.

60 Case LinearRace Supports for End Supported Applications

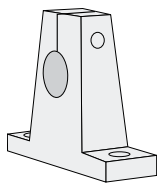

SB 60 Case LinearRace Shafting End Support Block Features:

- Size range between 1/4 and 2 inch.
- Easily secured with two mounting bolts.
- Malleable iron alloy for sizes 1/2 to 2 inch diameter.
- Protected by corrosion resistant coating.
- Light weight, high strength aluminum alloy construction for sizes 1/4 and 3/8 inch.

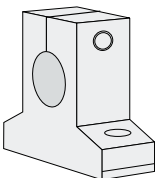

ASB Low Profile 60 Case LinearRace Shafting End Support Block Features:

- Size range between 1/4 and 1 1/2 inch.
- Low profile design.
- Easily secured with two mounting bolts.
- Protected by corrosion resistant anodized coating.
- Light weight, high strength aluminum alloy construction.

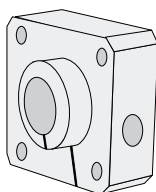

FSB Flanged 60 Case LinearRace End Support Block Features:

- Available in 1/2, 3/4, 1 and 1 1/4 inch diameters.
- Flanged mounting surface for easy assembly.
- Easily secured with four mounting bolts.
- Designed specifically for use with Super Smart Flanged Pillow Blocks.
- Protected by corrosion resistant coating.
- Light weight, high strength aluminum alloy construction.

Inch - 60 Case Shafting

Hardened and Ground 60 Case Precision LinearRace Shafting

Part Number Description

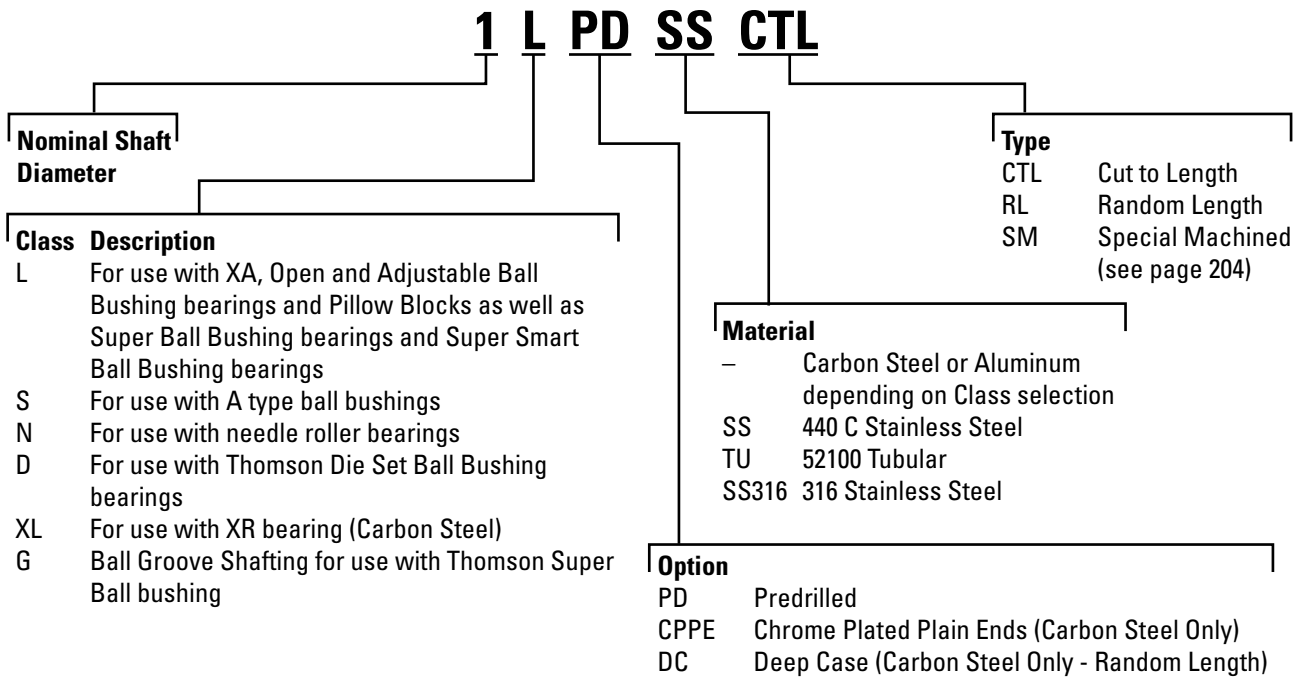

AL = Aluminum shafting, for use with FluoroNyliner bearings

CTL = Cut to length is Thomson 60 Case cut to your specified length.

RL = Random length is full bar or long length shafting. It is called random length because we start with a raw bar 4" to 6" longer than the min. usable but guarantee only the min. usable. We mark the ends of what is out of our own tolerance. This is the result of the manufacturing process and tightly controlled roundness specifications.

Look for the Brand Logo



If you specify Thomson, look for the logo. Do not be fooled when ordering linear shafting. All Thomson 60 Case LinearRace shafting is etched with the Thomson logo as shown in the picture. If the shaft you have does not have the logo, it may not be a true Thomson 60 Case. Thomson 60 Case is etched approximately every 18 to 22 inches.

Inch - 60 Case Shafting

Solid Carbon Steel

Hardness: 60 ROCKWELL C Min.

Surface Finish: 8 Ra Max

Roundness: .000080" Class L and S / .000050" Class N

Straightness: .001" Per Foot Cumulative (.002" TIR)

Taper: .0001"

Nominal Diameter (in)	Class L			Class S			Class N			Min. Hardness Depth (in)	Weight Per Inch (lb)
	Basic Part Number	Diameter Tolerance (in)	Max. Length (in)	Basic Part Number	Diameter Tolerance (in)	Max. Length (in)	Basic Part Number	Diameter Tolerance (in)	Max. Length (in)		
3/16"	3/16 L	.1870 .1865	54	-	-	-	-	-	-	.027	.008
1/4"	1/4 L	.2495 .2490	94	1/4 S	.2490 .2485	94	1/4 N	.2500 .2498	94	.027	.014
3/8"	3/8 L	.3745 .3740	166	3/8 S	.3740 .3735	166	3/8 N	.3750 .3748	166	.027	.031
1/2"	1/2 L	.4995 .4990	166	1/2 S	.4990 .4985	166	1/2 N	.5000 .4998	166	.040	.055
5/8"	5/8 L	.6245 .6240	202	5/8 S	.6240 .6235	202	5/8 N	.6250 .6248	202	.040	.086
3/4"	3/4 L	.7495 .7490	202	3/4 S	.7490 .7485	202	3/4 N	.7500 .7498	202	.060	.125
7/8"	7/8 L	.8745 .8740	202	-	-	-	7/8 N	.8750 .8748	202	.060	.170
1"	1 L	.9995 .9990	202	1 S	.9990 .9985	202	1 N	1.0000 .9998	202	.080	.222
1 1/8"	1 1/8 L	1.1245 1.1240	202	-	-	-	-	1.1250 1.1248	202	.080	.281
1 1/4"	1 1/4 L	1.2495 1.2490	202	1 1/4 S	1.2490 1.2485	202	1 1/4 N	1.2500 1.2498	202	.080	.348
1 3/8"	1 3/8 L	1.3745 1.3740	202	-	-	-	1 3/8 N	1.3750 1.3747	202	.080	.420
1 1/2"	1 1/2 L	1.4994 1.4989	202	1 1/2 S	1.4989 1.4984	202	1 1/2 N	1.5000 1.4997	202	.080	.500
1 5/8"	1 5/8 L	1.6245 1.6240	178	-	-	-	1 5/8 N	1.6250 1.6247	178	.080	.587
1 3/4"	1 3/4 L	1.7495 1.7490	178	-	-	-	1 3/4 N	1.7500 1.7497	178	.100	.681
2"	2 L	1.9994 1.9987	202	2 S	1.9987 1.9980	202	2 N	2.0000 1.9997	202	.100	.890
2 1/4"	2 1/4 L	2.2494 2.2487	202	-	-	-	2 1/4 N	2.2500 2.2497	202	.100	1.153
2 1/2"	2 1/2 L	2.4993 2.4985	202	2 1/2 S	2.4985 2.4977	202	2 1/2 N	2.5000 2.4996	202	.100	1.391
3"	3 L	2.9992 2.9983	202	3 S	2.9983 2.9974	202	3 N	3.0000 2.9996	202	.100	2.003
3 1/2"	3 1/2 L	3.4990 3.4980	202	-	-	-	-	-	-	.100	2.726
4"	4 L	3.9988 3.9976	202	4 S	3.9976 3.9964	202	-	-	-	.100	3.560

Inch 60 Case Shafting

Solid Carbon Steel

Hardness: 60 ROCKWELL C Min.

Straightness: .001" Per Foot Cumulative (.002" TIR)

Taper: .0001"

Roundness: .000080" Class D and XL

Nominal Diameter (in)	Class D				Min. Hardness Depth (in)	Weight Per Inch (lb)
	Basic Part Number	Diameter Tolerance (in)	Surface Finish	Max. Length (in)		
1"	1 D	1.0003 1.0000	8 Ra Max.	202	.080	.222
1 1/4"	1 1/4 D	1.2503 1.2500	8 Ra Max.	202	.080	.348
1 1/2"	1 1/2 D	1.5003 1.5000	8 Ra Max.	202	.080	.500
2"	2 D	2.0003 2.0000	8 Ra Max.	202	.100	.890

Nominal Diameter (in)	Class XL				Min. Hardness Depth (in)	Weight Per Inch (lb)
	Basic Part Number	Diameter Tolerance (in)	Surface Finish	Max. Length (in)		
2"	2 XL	1.9994 1.9991	4-8 Ra Max.	202	.100	.890
3"	3 XL	2.9992 2.9989	4-8 Ra Max.	202	.100	2.003
4"	4 XL	3.9988 3.9983	6-10 Ra Max.	202	.100	3.560

Inch - 60 Case Shafting

Standard Options for Carbon Steel Shafting

Chrome Plated Ends (CPPE), Predrilled (PD), Predrilled Chrome Plated Plain Ends (PDCPPE), Solid Steel

Hardness: 60 ROCKWELL C Min.

Surface Finish: 8 Ra Max

Roundness: .000080"

Straightness: .001" Per Foot Cumulative (.002" TIR)

Taper: .0001"

Nominal Diameter (in)	Chrome Plated Plain Ends			Min. Hardness Depth (in)	Weight Per Inch (lb)
	Part Number	Tolerance Class L	Max. Length (in)		
1/2"	1/2 L CPPE	.4995	166	.040	.055
		.4990			
5/8"	5/8 L CPPE	.6245	202	.040	.086
		.6240			
3/4"	3/4 L CPPE	.7495	202	.060	.125
		.7490			
1"	1 L CPPE	.9995	202	.080	.222
		.9990			
1 1/4"	1 1/4 L CPPE	1.2495	202	.080	.348
		1.2490			
1 1/2"	1 1/2 L CPPE	1.4994	202	.080	.500
		1.4989			
2"	2 L CPPE	1.9994	202	.100	.890
		1.9987			

CPPE - Chrome Plated Plain Ends which means ends and chamfers are not plated.

Completely plated chamfers are available as a special machine part. See page 208.

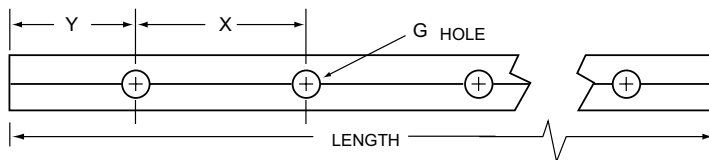

Nominal Diameter (in)	Predrilled		Predrilled Chrome Plated		Hole Spacing X (inch +/- 1/64) (noncumulative)	G Standard Thread Size	Length Tolerance (in)	Max. Length (in)	Min. Hardness Depth (in)	Weight Per Inch (lb)
	Part Number Predrilled	L PD Tolerance Class	Part Number Predrilled Chrome Plated Ends	L PD Tolerance Class						
1/2"	1/2 L PD	.4995	1/2 L PDCPPE	.4995	4	#6-32	+/- 1/32	166	.040	.055
		.4990		.4990						
5/8"	5/8 L PD	.6245	5/8 L PDCPPE	.6245	4	#8-32	+/- 1/32	178	.040	.086
		.6240		.6240						
3/4"	3/4 L PD	.7495	3/4 L PDCPPE	.7495	6	#10-32	+/- 1/32	178	.060	.125
		.7490		.7490						
1"	1 L PD	.9995	1 L PDCPPE	.9995	6	1/4-20	+/- 1/32	178	.080	.222
		.9990		.9990						
1 1/4"	1 1/4 L PD	1.2495	1 1/4 L PDCPPE	1.2495	6	5/16-18	+/- 1/32	178	.080	.348
		1.2490		1.2490						
1 1/2"	1 1/2 L PD	1.4994	1 1/2 L PDCPPE	1.4994	8	3/8-16	+/- 1/32	178	.080	.500
		1.4989		1.4989						
2"	2 L PD	1.9994	2 L PDCPPE	1.9994	8	1/2-13	+/- 1/16	178	.100	.890
		1.9987		1.9987						

Holes are drilled and tapped to the center of the shaft. Y = distance from end of rail to the center of first mounting hole, Y1 = Y2 unless specified.

Chrome plating is thin, dense chrome with thickness of .00005 - .0001".

Inch - 60 Case Shafting

Solid Steel Deep Case - Available in Random Length Only

Hardness: 60 ROCKWELL C Min.

Straightness: .001" Per Foot Cumulative (.002" TIR)

Surface Finish: 8 Ra Max

Taper: .0001"

Roundness: .000080" Class L and S / .000050" Class N

Nominal Diameter (in)	Class L Deep Case			Class N Deep Case			Min. Hardness SS Depth (in)	Weight Per Inch (lb)
	Basic Part Number	Diameter Tolerance (in)	Max. Length (in)	Basic Part Number	Diameter Tolerance (in)	Max. Length (in)		
3/4"	3/4 L DC	.7495	202	3/4 N DC	.7500	202	.120	.125
		.7490			.7498			
7/8"	7/8 L DC	.8745	202	7/8 N DC	.8750	202	.120	.170
		.8740			.8748			
1"	1 L DC	.9995	202	1 N DC	1.0000	202	.160	.222
		.9990			.9998			
1 1/8"	1 1/8 L DC	1.1245	202	1 1/8 N DC	1.1250	202	.160	.281
		1.1240			1.1248			
1 1/4"	1 1/4 L DC	1.2495	202	1 1/4 N DC	1.2500	202	.180	.348
		1.2490			1.2498			
1 1/2"	1 1/2 L DC	1.4994	202	1 1/2 N DC	1.5000	202	.180	.500
		1.4989			1.4997			
1 3/4"	1 3/4 L DC	1.7495	178	1 3/4 N DC	1.7500	178	.250	.681
		1.7490			1.7497			
2"	2 L DC	1.9994	202	2 N DC	2.0000	202	.250	.890
		1.9987			1.9997			
2 1/4"	2 1/4 L DC	2.2494	202	2 1/4 N DC	2.2500	202	.250	1.153
		2.2487			2.2497			
2 1/2"	2 1/2 L DC	2.4993	202	2 1/2 N DC	2.5000	202	.250	1.391
		2.4985			2.4996			
3"	3 L DC	2.9992	202	3 N DC	3.0000	202	.250	2.003
		2.9983			2.9996			
3 1/2"	3 1/2 L DC	3.4990	202	-	-	-	.250	2.726
		3.4980						

Inch 60 Case Shafting

Ball Groove LinearRace Shaft - Solid Carbon Steel

Hardness: 60 ROCKWELL C Min.

Surface Finish: 8 Ra Max

Roundness: .000080"

Straightness: Shaft Groove .002" Per Foot Cumulative (.002" TIR)

Taper: .0001"

Nominal Diameter (in)	Basic Part Number	Class G		Min. Hardness Depth (in)	Weight Per Inch (lb)
		Diameter Tolerance (in)	Max. Length (in)		
1/4"	1/4 G	.2495	45	.027	.014
		.2490			
3/8"	3/8 G	.3745	45	.027	.031
		.3740			
1/2"	1/2 G	.4995	45	.040	.055
		.4990			
5/8"	5/8 G	.6245	45	.040	.086
		.6240			
3/4"	3/4 G	.7495	45	.060	.125
		.7490			
1"	1 G	.9995	45	.080	.222
		.9990			

Inch - 60 Case Shafting

440C Stainless Steel

Hardness: 50 ROCKWELL C Min.

Surface Finish: 8 Ra Max

Roundness: .000080"

Straightness: .001" Per Foot Cumulative (.002" TIR)

Taper: .0001"

Nominal Diameter (in)	Class L			Class S			Min. Hardness SS Depth (in)	Weight Per Inch (lb)
	Basic Part Number	Diameter Tolerance (in)	Max. Length (in)	Basic Part Number	Diameter Tolerance (in)	Max. Length (in)		
3/16"	3/16 L SS	.1870	54					
		.1865						
1/4"	1/4 L SS	.2495	94	1/4 S SS	.2490	94	.027	.014
		.2490			.2485			
3/8"	3/8 L SS	.3745	178	3/8 S SS	.3740	178	.027	.031
		.3740			.3735			
1/2"	1/2 L SS	.4995	178	1/2 S SS	.4990	178	.040	.055
		.4990			.4985			
5/8"	5/8 L SS	.6245	178	5/8 S SS	.6240	178	.040	.086
		.6240			.6235			
3/4"	3/4 L SS	.7495	178	3/4 S SS	.7490	178	.060	.125
		.7490			.7485			
1"	1 L SS	.9995	178	1 S SS	.9990	178	.080	.222
		.9990			.9985			
1 1/4"	1 1/4 L SS	1.2495	178	1 1/4 S SS	1.2490	178	.080	.348
		1.2490			1.2485			
1 1/2"	1 1/2 L SS	1.4994	178	1 1/2 S SS	1.4989	178	.080	.500
		1.4989			1.4984			
2"	2 L SS	1.9994	178	2 S SS	1.9987	178	.100	.890
		1.9987			1.9980			
2 1/2"	2 1/2 L SS	2.4993	178	2 1/2 S SS	2.4985	178	.100	1.391
		2.4985			2.4977			

440C stainless is "corrosion resistant"; it contains some carbon which allows for hardening. Carbon can result in corrosion over time.

Standard Options for 440C Stainless Steel Predrilled (PD)

Hardness: 50 ROCKWELL C Min.

Surface Finish: 8 Ra Max

Straightness: .001" Per Foot Cumulative (.002" TIR)

Roundness: .000080"

Taper: .0001"

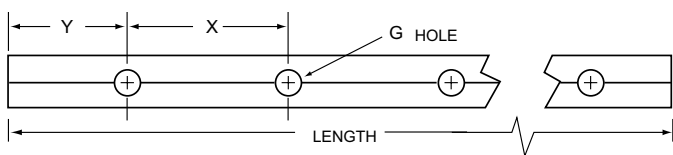

Nominal Diameter (in)	Predrilled		Hole Spacing X (inch +/- 1/64) (noncumulative)	G Standard Thread Size	Length Tolerance (in)	Max. Length (in)	Min. Hardness Depth (in)	Weight Per Inch (lb)
	Part Number Predrilled	L PD Tolerance Class						
1/2"	1/2 L PD SS	.4995	4	#6-32	+/- 1/32	166	.040	.055
		.4990						
5/8"	5/8 L PD SS	.6245	4	#8-32	+/- 1/32	178	.040	.086
		.6240						
3/4"	3/4 L PD SS	.7495	6	#10-32	+/- 1/32	178	.060	.125
		.7490						
1"	1 L PD SS	.9995	6	1/4-20	+/- 1/32	178	.080	.222
		.9990						
1 1/4"	1 1/4 L PD SS	1.2495	6	5/16-18	+/- 1/32	178	.080	.348
		1.2490						
1 1/2"	1 1/2 L PD SS	1.4994	8	3/8-16	+/- 1/32	178	.080	.500
		1.4989						
2"	2 L PD SS	1.9994	8	1/2-13	+/- 1/16	178	.100	.890
		1.9987						

Holes are drilled and tapped to the center of the shaft. Y = distance from end of rail to the center of first mounting hole, Y1 = Y2 unless specified.

Inch - 60 Case Shafting

Ball Groove LinearRace Shaft - 440C Stainless Steel

Hardness: 50 ROCKWELL C Min.

Roundness: .000080"

Surface Finish: 8 Ra Max

Taper: .0001"

Straightness: Shaft Groove .002" Per Foot Cumulative

Nominal Diameter (in)	Class G			Min. Hardness Depth (in)	Weight Per Inch (lb)
	Basic Part Number	Diameter Tolerance (in)	Max. Length (in)		
1/4"	1/4 G SS	.2495	45	.027	.014
		.2490			
3/8"	3/8 G SS	.3745	45	.027	.031
		.3740			
1/2"	1/2 G SS	.4995	45	.040	.055
		.4990			
5/8"	5/8 G SS	.6245	45	.040	.086
		.6240			
3/4"	3/4 G SS	.7495	45	.060	.125
		.7490			
1"	1 G SS	.9995	45	.080	.222
		.9990			

Instrument 440C Stainless Steel LinearRace shafting for use with Thomson Instrument

Ball bushing bearings

Hardness: 55 ROCKWELL C Min.

Straightness: .001" Per Inch Cumulative

Surface Finish: 4 Ra Max

Taper: .0001"

Roundness: .000080"

Nominal Diameter (in)	INST Class			Max. Length (in)	Min. Hardness Depth (in)	Weight Per Inch (lb)
	Basic Part Number	Diameter Tolerance (in)	Length Tolerance (in)			
1/8"	1/8 INST	.1248	+/- .005	12	.027	.004
		.1247				
3/16"	3/16 INST	.1873	+/- .005	12	.027	.008
		.1872				
1/4"	1/4 INST	.2498	+/- .005	12	.027	.014
		.2497				

52100 Tubular

Hardness: 58 ROCKWELL C Min.

Roundness: .000080" Class L and S

Surface Finish: 8 Ra Max

Taper: .0001"

Straightness: .001" Per Foot Cumulative (.002" TIR)

Nominal Diameter (in)	Nominal I.D. (in)	Class L			Class S			Min. Hardness Depth (in)	Weight Per Inch (lb)
		Basic Part Number	Diameter Tolerance (in)	Max. Length (in)	Basic Part Number	Diameter Tolerance (in)	Max. Length (in)		
3/4"	.46	3/4 L TU	.7495	174	3/4 S TU	.7490	174	.060	.0754
	.42		.7490			.7485			
1"	.63	1 L TU	.9995	174	1 S TU	.9990	174	.080	.158
	.57		.9990			.9985			
1 1/2"	.93	1 1/2 L TU	1.4994	174	1 1/2 S TU	1.4989	174	.080	.328
	.85		1.4989			1.4984			
2"	1.32	2 L TU	1.9994	174	2 S TU	1.9987	174	.100	.542
	1.19		1.9987			1.9980			
2 1/2"	1.84	2 1/2 L TU	2.4993	174	2 1/2 S TU	2.4985	174	.100	.749
	1.66		2.4985			2.4977			
3"	2.20	3 L TU	2.9992	174	3 S TU	2.9983	174	.100	1.112
	1.80		2.9983			2.9974			
4"	3.30	4 L TU	3.9988	174	4 S TU	3.9976	174	.100	1.558
	2.70		3.9976			3.9964			

Inch - 60 Case Shafting

316 Stainless Steel

Hardness: 20-25 ROCKWELL C Min.

Roundness: .000080"

Surface Finish: 8 Ra Max

Straightness: .001" Per Foot Cumulative (.002" TIR)

Taper: .0001"

Nominal Diameter (in)	Basic Part Number	Class L		Weight Per Inch (lb)
		Diameter Tolerance (in)	Max. Length (in)	
1/4"	1/4 L SS316	.2495 .2490	94	.014
3/8"	3/8 L SS316	.3745 .3740	138	.031
1/2"	1/2 L SS316	.4995 .4990	138	.055
5/8"	5/8 L SS316	.6245 .6240	138	.086
3/4"	3/4 L SS316	.7495 .7490	138	.125
1"	1 L SS316	.9995 .9990	138	.222
1 1/4"	1 1/4 L SS316	1.2495 1.2490	138	.348
1 1/2"	1 1/2 L SS316	1.4994 1.4989	138	.500
2"	2 L SS316	1.9994 1.9987	138	.890

316 Stainless Steel is corrosion proof steel and has no carbon content which will result in corrosion.

Standard Options for 316 Stainless Steel Predrilled (PD)

Hardness: 20-25 ROCKWELL C Min.

Surface Finish: 8 Ra Max

Roundness: .000080"

Straightness: .001" Per Foot Cumulative (.002" TIR)

Taper: .0001"

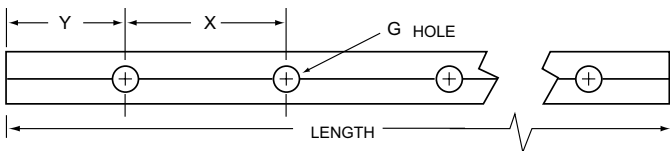

Nominal Diameter (in)	Predrilled		Hole Spacing X (inch +/- 1/64) (noncumulative)	G Standard Thread Size	Length Tolerance (in)	Max. Length (in)	Weight Per Inch (lb)
	Part Number Predrilled	L PD Tolerance Class					
1/2"	1/2 L SS316PD	.4995 .4990	4	#6-32	+/- 1/32	166	.055
5/8"	5/8 L SS316PD	.6245 .6240	4	#8-32	+/- 1/32	178	.086
3/4"	3/4 L SS316PD	.7495 .7490	6	#10-32	+/- 1/32	178	.125
1"	1 L SS316PD	.9995 .9990	6	1/4-20	+/- 1/32	178	.222
1 1/4"	1 1/4 SS316PD	1.2495 1.2490	6	5/16-18	+/- 1/32	178	.348
1 1/2"	1 1/2 SS316PD	1.4994 1.4989	8	3/8-16	+/- 1/32	178	.500
2"	2 L SS316PD	1.9994 1.9987	8	1/2-13	+/- 1/16	178	.890

Holes are drilled and tapped to the center of the shaft. Y = distance from end of rail to the center of first mounting hole, Y1 = Y2 unless specified.

Inch - Shafting

Ultra Light Aluminum

Hardness: 70 HRC Min (coating)
 Coating Thickness: .0015 - .002
 Roundness: .000080 Max
 Surface Finish: 16 Ra Max
 Straightness: .001 Max Per Foot Cumulative (.002 TIR)
 Taper: .0001 Max
 Max Length: 120



Inch Ultra Light Shafting

Nominal Diameter	Part Number	Diameter Tolerance		Length Tolerance	Weight Per Inch (lbs)
		Min	Max		
1/4	1/4 AL	0.2488	0.2496	+/- 1/32	0.005
3/8	3/8 AL	0.3738	0.3746	+/- 1/32	0.010
1/2	1/2 AL	0.4988	0.4996	+/- 1/32	0.019
5/8	5/8 AL	0.6238	0.6246	+/- 1/32	0.030
3/4	3/4 AL	0.7488	0.7496	+/- 1/32	0.043
1	1 AL	0.9988	0.9996	+/- 1/32	0.077

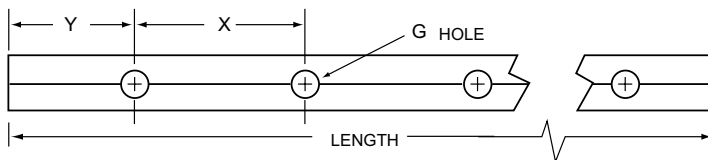

Inch Ultra Light Predrilled Shafting

Nominal Diameter	Part Number	Diameter Tolerance		Hole Spacing		Thread Size G	Length Tolerance	Weight Per Inch (lbs)
		Min	Max	X	Y			
1/2	1/2 AL PD	0.4988	0.4996	4	2	#6-32	+/- 1/32	0.019
5/8	5/8 AL PD	0.6238	0.6246	4	2	#8-32	+/- 1/32	0.03
3/4	3/4 AL PD	0.7488	0.7496	6	3	#10-32	+/- 1/32	0.043
1	1 AL PD	0.9988	0.9996	6	3	1/4-20	+/- 1/32	0.077

Inch 60 Case Shafting

Inch - Support Rails and Support Rail Assemblies

Support Rails and Assemblies for Continuously Supported Applications

Part Number Description

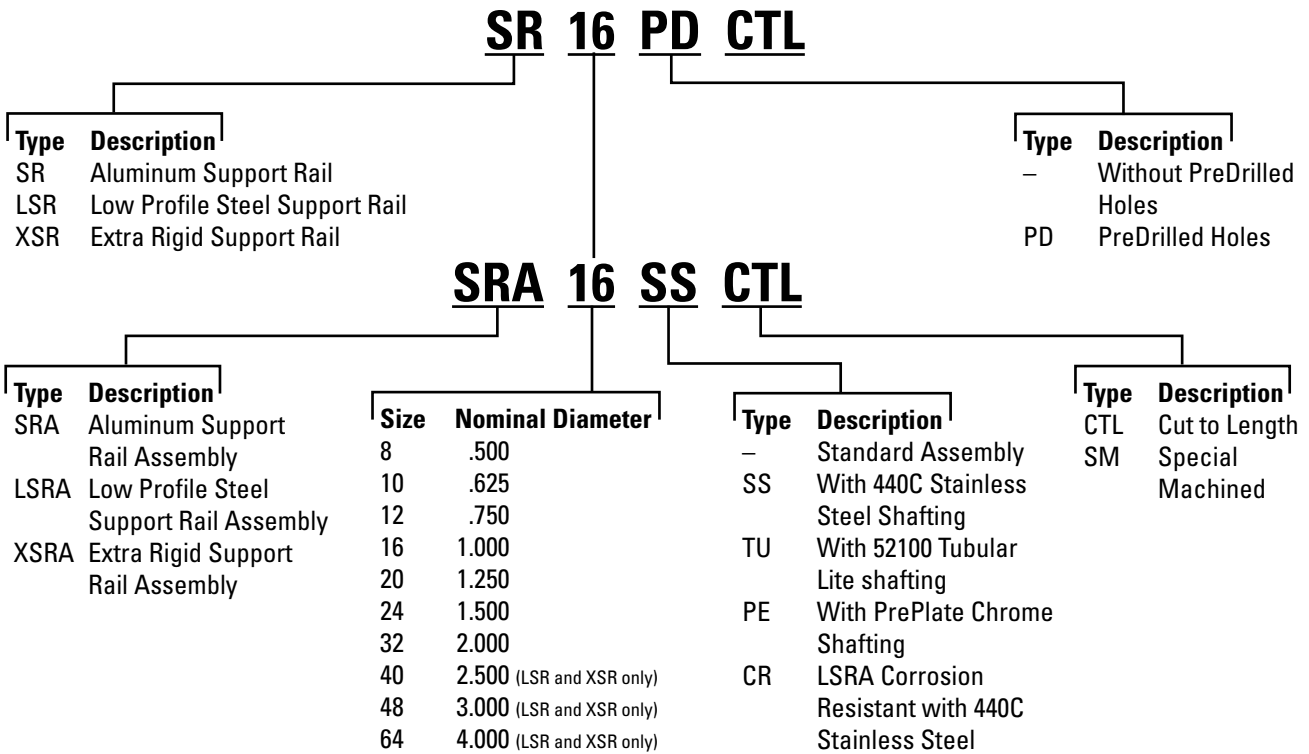

Inch - Support Rails and Support Rail Assemblies

Shaft Rail Supports Type SR & SR-PD

The low cost way of mounting Thomson 60 Case Shafts

Shaft supports simplify mounting of Thomson 60 Case shafts. Users of Thomson 60 Case shafting should carefully consider the use of these low cost shaft supports. They are standard, available from stock, and simplify shaft mounting. In addition to other benefits, they eliminate many problems encountered in designing and manufacturing shaft supporting devices. These versatile mounts can be used horizontally or vertically, and in many different arrangements. Shaft support rails are available without pre-drilled holes (SR) or pre-drilled (SR-PD) shaft rails to support 1/2 inch through 2 inch diameter shafts are available in standard 24, 48 and 72 inch lengths*. Where shorter lengths are needed, rails are easily cut to length. For longer shafts they can be mounted end to end, using shims or grout, if necessary, to compensate for slight variation within manufacturing tolerance. Thomson offers shaft support rails with pre-drilled holes to simplify shaft mounting.

Low Shaft Support Rails Type LSR & LSR-PD

For compact designs

Low Shaft Rails allow the design of more compact linear motion systems. The height from the base to the mean shaft center ranges from 9/16 inch for supporting a 1/2 inch diameter shaft to a maximum 3 1/2 inches when supporting a 4 inch diameter shaft – 40% lower than standard support rails. Low Shaft Rails are made of steel to maintain optimum shaft rigidity. Either continuous or intermittent support is possible when using Thomson open-type linear ball bearings. Low Shaft Rails are furnished in standard 4-foot lengths. Where shorter lengths are required, rails can be cut. For supporting longer shafts, rails can be mounted end-to-end without limit. Low Shaft Rails are available without pre-drilled mounting holes (LSR) or with pre-drilled mounting holes (LSR-PD) to match Thomson drilled and tapped shafts (PD). When using LSR-PD, the attachment bolts are underneath, so you must have access under your machine base plate. The LSRA assemblies highlighted below utilize attachment bolts from above. If one of the standard pre-drilled Low Shaft Rails is not appropriate for your design needs, Low Shaft Rails can be custom drilled by Thomson to your specifications.

Send a print with all required dimensions, tolerances, and quantities needed to our application engineering team.

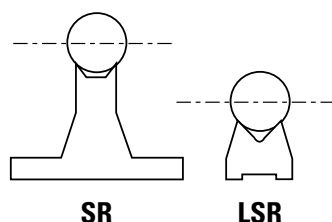

SR

LSR

*Maximum continuous length is 71.94"

Extra-Rigid Shaft Support Rails

For XR Ball Bushing bearing systems

Extra-rigid shaft support rails (XSR) are designed specifically for use with our extra-rigid Series XR Ball Bushing bearings. XSR support rails are available in nominal 24 inch lengths and are made of ductile iron and powder epoxy coated to provide the most deflection-resistant shaft support of all Thomson supports. To facilitate quick and easy installation, each extra-rigid shaft support is drilled and counter-bored for securing a drilled and tapped shaft into it and for bolting it to a flat, rigid base. For supporting long shafts, XSR support rails can be mounted end-to-end.

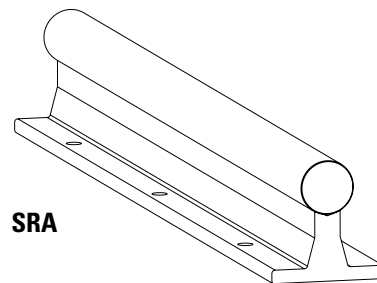

SRA

Pre-Assembled Shaft Rail Assemblies Type SRA & LSRA

Thomson 60 Case steel shafts mounted on shaft support rails are now available for instant bolt-down installation. Assemblies are supplied cut to any length, with no limit on the overall length (long lengths are butt jointed together unless specified otherwise). Either solid or light-weight tubular shafting can be assembled to the standard Thomson support rails, which come with base mounting holes spaced evenly along the overall length of the assembly. The LSRA uses a special shaft unlike the LSR-PD. The attachment bolts for the LSRA are from the top down so you can easily mount into a machine base plate. The LSRA bolt pattern closely matches Profile Rail Linear Guides and can easily be used as a drop-in substitute to replace linear guides (ensure you review loading requirements). Corrosion resistant lower support rail assemblies (LSRA) are available. The support is zinc plated and shaft is 440C.

Inch - Support Rails and Support Rail Assemblies

Support Rails and Assemblies for Continuously Supported Applications

Type SR/SR-PD 60 Case LinearRace Support Rails and Assemblies (Dimensions in inches)

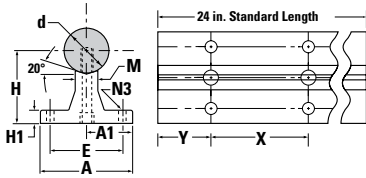

Material: Aluminum Alloy
(Longer Lengths are Available)

SR Without Holes	SR-PD With PreDrilled Holes	Nominal LinearRace Diameter d	H ±.002	H1	A	A1	E	M	N3		LinearRace Mounting Bolt N1 (PD only)	X	Weight lb/ft
									Hole	Bolt			
SR8	SR8-PD	.500	1.125	.19	1.50	.750	1.00	.25	.17	#6	#6-32 x .88	4	.60
SR10	SR10-PD	.625	1.125	.25	1.63	.813	1.13	.31	.19	#8	#8-32 x .88	4	.80
SR12	SR12-PD	.750	1.500	.25	1.75	.875	1.25	.38	.22	#10	#10-32 x 1.25	6	1.00
SR16	SR16-PD	1.000	1.750	.25	2.13	1.063	1.50	.50	.28	1/4	1/4-20 x 1.5	6	1.40
SR20	SR20-PD	1.250	2.125	.31	2.50	1.250	1.88	.56	.34	5/16	5/16-18 x 1.75	6	2.10
SR24	SR24-PD	1.500	2.500	.38	3.00	1.500	2.25	.69	.34	5/16	3/8-16 x 1.75	8	2.60
SR32	SR32-PD	2.000	3.250	.50	3.75	2.750	2.75	.88	.406	3/8	1/2-13 x 2.50	8	4.20

N1 Hole Dia. includes counterbore for socket head cap screw. Alignment and location of holes are are ± .010, noncumulative. Y = distance from end of rail to the center of first mounting hole, Y1 = Y2 unless specified.

Type LSR and LSR-PD 60 Case LinearRace Support Rails (Dimensions in inches)

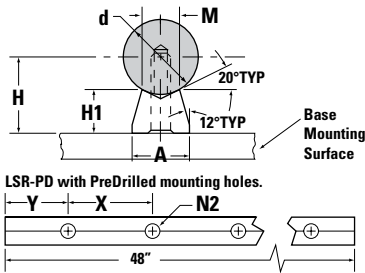

Material: Steel Alloy
(Longer Lengths are Available)

LSR Standard Without Holes	LSR-PD Standard w/PreDrilled Holes	Nominal LinearRace Diameter d	H ±.002	H1	A	M	N2		N1	X	Weight lb/ft
							Hole	Bolt			
LSR-8	LSR-8-PD	.500	.562	.34	.37	.25	.17	#6-32	4	.32	
LSR-10	LSR-10-PD	.625	.687	.41	.45	.31	.19	#8-32	4	.49	
LSR-12	LSR-12-PD	.750	.750	.42	.51	.38	.22	#10-32	6	.59	
LSR-16	LSR-16-PD	1.000	1.000	.56	.69	.50	.28	1/4-20	6	1.01	
LSR-20	LSR-20-PD	1.250	1.187	.63	.78	.56	.34	5/16-18	6	1.27	
LSR-24	LSR-24-PD	1.500	1.375	.70	.93	.69	.41	3/8-16	8	1.68	
LSR-32	LSR-32-PD	2.000	1.750	.845	1.180	.875	.531	1/2-13	8	2.59	
LSR-40	LSR-40-PD	2.500	2.250	1.125	1.500	1.125	.687	5/8-11	8	4.48	
LSR-48	LSR-48-PD	3.000	2.750	1.404	1.875	1.375	.812	3/4-10	8	6.68	
LSR-64	LSR-64-PD	4.000	3.500	1.750	2.500	1.875	1.060	1-8	8	11.8	

Y = distance from end of rail to the center of first mounting hole, Y1 = Y2 unless specified.

Type XSR Shaft Support Rails (Dimensions in inches)

Part Number	Nominal Shaft Diameter	A† +.000/- .001	B	C	D	E	Screw Diameter	F Hole	C Bore	Recommended Screw	G Hole	C Bore	H Degrees	Weight lb/ft
XSR-32	2	2.750	4-1/2	7/8	1	3-1/8	1/2	9/16	1 x 5/8 DP	1/2-13 x 2	9/16	1 x 3/4 DP	15	16
XSR-48	3	4.000	6	1-1/4	1-5/16	4-1/4	5/8	11/16	1 1/4 x 3/4 DP	3/4-10 x 2-3/4	13/16	1 7/16 x 1 1/8 DP	25	31

† Centerline of shaft will be parallel to base within .0005.
Surface dimensions as cast

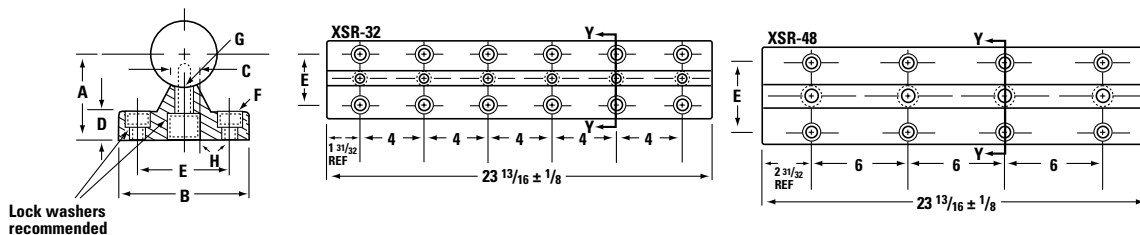

Inch - Support Rails and Support Rail Assemblies

Standard Shaft Rail Assemblies (Dimensions in inches)

Assembly Number			Nominal Linear Bearing Race Dia.	Dimensions							Base Holes		Weight lb/ft	
With Solid Carbon Steel Shaft	With Solid Stainless Steel Shaft	With Tubular 52100		A ±.002	B	C	D	E	F		X	SRA and SRA-SS	SRA-TU	
									Bolt	Hole				
SRA-8	SRA-8-SS	-	1/2	1.125	1 1/2	1/4	3/16	1	#6	.169	4	1.26	-	
SRA-10	SRA-10-SS	-	5/8	1.125	1 5/8	5/16	1/4	1 1/8	#8	.193	4	1.83	-	
SRA-12	SRA-12-SS	SRA-12-TU	3/4	1.500	1 3/4	3/8	1/4	1 1/4	#10	.221	6	2.50	1.90	
SRA-16	SRA-16-SS	SRA-16-TU	1	1.750	2 1/8	1/2	1/4	1 1/2	1/4	.281	6	4.06	3.30	
SRA-20	SRA-20-SS	-	1 1/4	2.125	2 1/2	9/16	5/16	1 7/8	5/16	.343	6	6.28	-	
SRA-24	SRA-24-SS	SRA-24-TU	1 1/2	2.500	3	11/16	3/8	2 1/4	5/16	.343	8	8.60	6.54	
SRA-32	SRA-32-SS	SRA-32-TU	2	3.250	3 3/4	7/8	1/2	2 3/4	3/8	.406	8	14.88	10.70	

Support Rail Material: Aluminum alloy extrusion. Base mounting hole locations are within ±.010 (noncumulative).

Notes: Lengths longer than 48" will use end to end support rails. Y = distance from end of rail to the center of first mounting hole, Y1 = Y2 unless specified.

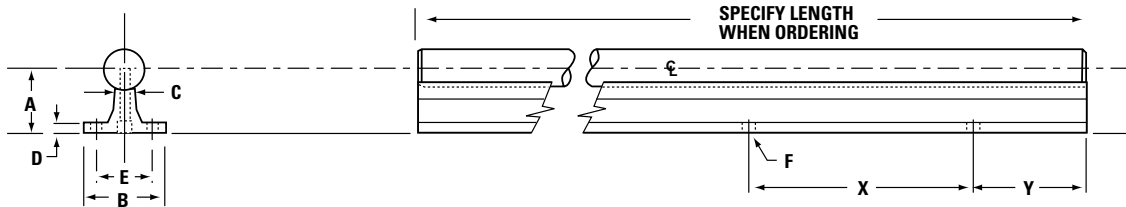

Type LSRA 60 Case Smart Rail Guides (Dimensions in inches)

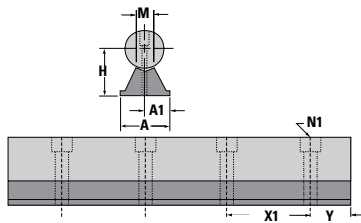

Material: Steel Alloy (Longer Lengths are Available)

Part Number ⁽³⁾		LinearRace Shafting Diameter	H ±.002	A	A1	M	Mounting Holes		Weight lb/ft
Smart Rail Assembly ⁽¹⁾	Smart Rail Assembly ⁽²⁾						X1	N1	
LSRA10	LSRA10 CR	.625	.687	.45	.225	.31	2	#5	1.57
LSRA12	LSRA12 CR	.750	.750	.51	.255	.38	3	#6	2.09
LSRA16	LSRA16 CR	1.000	1.000	.69	.345	.5	3	#10	3.67
LSRA20	LSRA20 CR	1.250	1.187	.78	.390	.56	3	5/16	5.86
LSRA24	LSRA24 CR	1.500	1.375	.93	.465	.69	4	3/8	7.68

(1) Consists of black oxide steel rail and high carbon steel LinearRace shafting (HRC 60 min.).

(2) Consists of zinc plated steel rail and 440C stainless steel LinearRace shafting (HRC 50 min.).

(3) Specify length of assembly when ordering. For example, LSRA12CR x 24.00 inches.

Y dimension is equal on each end unless specified by customer.

NOTE: LSRA's do not use standard "PD" shafting. The shafting requires a different hole pattern and configuration.

XSRA Extra Rigid Shaft Rail Assemblies (Dimensions in inches)

Assembly Number		LinearRace Shafting Diameter	Dimensions								Base Holes		Weight lb/ft	
With Solid Carbon Steel Shaft	With Tubular Carbon Steel Shaft		A +.000/- .001	B	C	D	E	F			X	XSRA	XSRA-TU	
								Screw Dia.	Hole	C Bore				
XSRA-32	XSRA-32-TU	2	2.750	4 1/2	7/8	1	3 1/8	1/2	9/16	1 x 5/8 DP	4	40.04	22.50	
XSRA-48	XSRA-48-TU	3	4.000	6	1 1/4	1 5/16	4 1/4	5/8	11/16	1 1/4 x 3/4 DP	6	73.72	49.70	

Note: Lengths longer than 24" will use end to end support rails. Y = distance from end of rail to the center of first mounting hole, Y1 = Y2 unless specified.

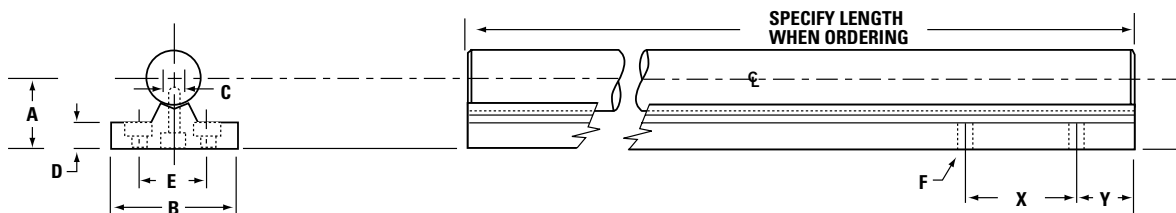

Inch - Support Blocks

Support Blocks for End Supported Applications

Part Number Description

ASB 16

Type	Description	Size	Nominal Diameter
ASB	Low Profile 60 Case LinearRace End Support Block	4	.250
SB	Standard 60 Case LinearRace End Support Block	6	.375
FSB	Flanged 60 Case LinearRace End Support Block	8	.500
WM	Waymount Support	10	.625
		12	.750
		16	1.000
		20	1.250
		24	1.500
		32	2.000
		48	3.000
		64	4.000

All sizes are not available for all support block types.
See specific product charts for size availability.

Inch - Support Blocks

Shaft Support Blocks – Type ASB and SB

For end support or intermittent support

Shaft support blocks are used for end or intermittent support where loads are light and deflection between supports is not a problem. Unlike shaft support rails, blocks do not permit longitudinal passage of open-type Ball Bushing bearings. Type SB shaft support blocks enable clamping of shafts and eliminate the need for bolts, etc. to maintain shaft position. Shimming is suggested for high precision applications to eliminate the effect of variations in surface of base or manufacturing tolerances between supports.



Type ASB shaft blocks, manufactured from high strength extruded aluminum, provide either end or intermittent support in applications where loads are designed with a reference edge on one side of the base. This provides a surface parallel to the center of the shaft within $\pm.001$ " that can be used to simplify shaft alignment.

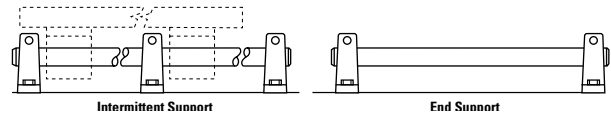

Type ASB 60 Case LinearRace Shaft End Support Blocks (Dimensions in inches)

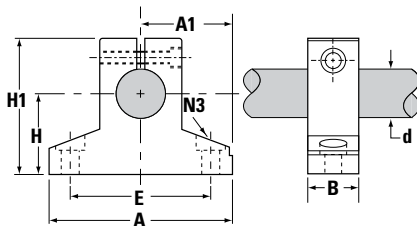

Material: Aluminum Alloy

Part ⁽²⁾ Number	Nominal LinearRace Diameter d	H $\pm.001$	H1	A	A1 $\pm.001$	B	E	N3		Weight lb
								Hole	Bolt	
ASB-4	.250	.500	.89	1.50	.750	.50	1.12	.16	#6	.06
ASB-6	.375	.562	1.00	1.62	.813	.56	1.25	.16	#6	.08
ASB-8	.500	.875	1.48	2.00	1.000	.63	1.50	.19	#8	.11
ASB-12	.750	1.125	1.95	2.50	1.250	.75	2.00	.22	#10	.22
ASB-16	1.000	1.375	2.48	3.25	1.625	1.00	2.50	.28	1/4	.44
ASB-24	1.500	2.000	3.50	4.75	2.375	1.25	3.50	.34	5/16	1.16

Type SB 60 Case LinearRace Shaft End Support Blocks (Dimensions in inches)

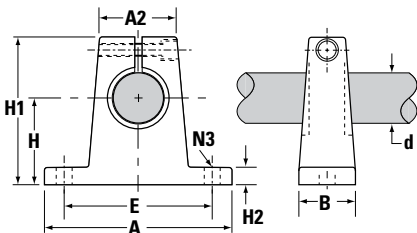

Material: Malleable Iron for sizes .5 to 2 in.
Aluminum Alloy for sizes .25 and .375 in.

Part ⁽²⁾ Number	Nominal LinearRace Diameter d	H $\pm.002$	H1	H2	A	A2	B	E $\pm.010$	N3		Weight lb
									Hole	Bolt	
SB-4	.250	.687	1.06	.25	1.50	.63	.50	1.125	.16	#6	.03
SB-6	.375	.750	1.19	.25	1.63	.69	.56	1.250	.16	#6	.05
SB-8	.500	1.000	1.63	.25	2.00	.75	.63	1.500	.19	#8	.30
SB-10	.625	1.000	1.75	.31	2.50	.88	.69	1.875	.22	#10	.40
SB-12	.750	1.250	2.13	.31	2.75	1.00	.75	2.000	.22	#10	.50
SB-16	1.000	1.500	2.56	.38	3.25	1.38	1.00	2.500	.28	.25	1.0
SB-20	1.250	1.750	3.00	.44	4.00	1.75	1.13	3.000	.34	.31	2.0
SB-24	1.500	2.000	3.50	.50	4.75	2.00	1.25	3.500	.34	.31	2.6
SB-32	2.000	2.500	4.50	.63	6.00	2.63	1.50	4.500	.41	3/8	4.8

Inch - Shaft Support Blocks

Shaft Support Blocks – Type FSB

Thomson Flanged Support Blocks offer perpendicular mounting without the need for special adaptor brackets.

Type FSB Flanged 60 Case LinearRace Shaft End Support Blocks (Dimensions in inches)

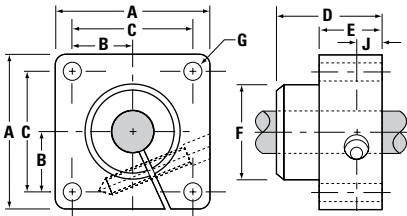

Material: Aluminum Alloy

Part Number	Nominal LinearRace Diameter d	A ±.001	B	C ±.010	D	E	F	G		J	Weight lb
								Hole	Bolt		
FSB-8	.500	1.63	.63	1.250	.88	.50	1.00	.81	#8	.25	.3
FSB-12	.750	2.38	.88	1.750	1.00	.63	1.25	.21	#10	.31	.6
FSB-16	1.000	2.75	1.06	2.125	1.25	.63	1.50	.27	1/4	.31	.8
FSB-20	1.250	3.13	1.19	2.375	1.38	.75	1.75	.27	1/4	.38	.9

Waymount Support For adjustable support

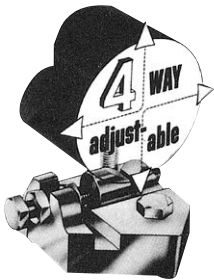

Designed for use with Roundway bearings. Two or more can be used to provide intermittent support and adjustment along the length of the shaft. Unlike shaft support rails, Waymount supports do not permit longitudinal passage of open-type Ball Bushing bearings. When it is necessary to travel over Waymount supports, Roundway bearings should be used. Open-type Ball Bushing bearings can be used only if side loads are light and an adapter block is used (consult factory for recommendation).

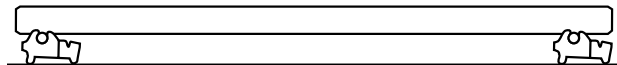

End Support

Waymount Supports (Dimensions in inches)

Waymount Part Number	D RoundWay Diameter	L	H†	W	A	B	C	E	F	G	J	K	M	N	P	Weight (lbs)
WM-8	1/2	1 1/2	1 1/16	1 3/4	1/2	7/8	1/4	3/4	7/32	8-32	3/64	3/32	11/16	1/2	7/16	.2
WM-16	1	2	1 1/2	2 1/2	3/4	1 1/4	5/16	1 1/16	9/32	1/4-28	1/16	1/8	13/16	11/16	11/16	.5
WM-24	1 1/2	2 1/2	2	3 1/2	13/16	1 5/8	7/16	1 3/16	11/32	5/16-24	1/8	1/8	1	3/4	3/4	1.1
WM-32	2	3	2 1/2	4	1 7/16	1 7/8	1/2	1 3/8	13/32	3/8-24	1/8	1/8	1 1/4	15/16	1	1.8
WM-48	3	5	4 5/16	6 3/4	2 3/8	3 3/8	3/4	2 5/8	21/32	5/8-18	1/8	1/8	2 1/4	1 5/8	1 1/2	10.2
WM-64	4	6 1/2	5 7/16	8 1/2	3	4 1/4	1	3 1/8	25/32	3/4-16	1/8	1/8	2 3/4	2	2	21.2

In-Between Shaft Sizes: Waymount supports will accommodate all shaft sizes from approximately 3/8" to 6" diameter. Use the Waymount support size nearest to your particular shaft diameter. Favor the next largest Waymount support if the shaft size falls midway between two of them. The mean centering height "H" will vary somewhat with different diameter shafts.

† Please note difference in dimension between shaft centerline of rails, blocks and Waymount supports. Shimming or blocking is suggested when these are used on a single shaft.

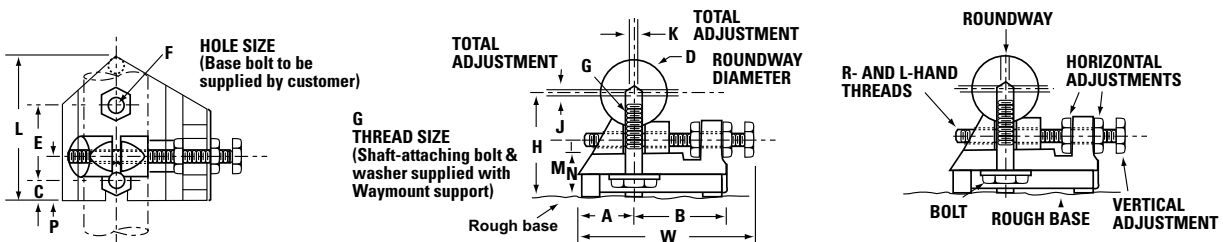

Metric - 60 Case Shafting

Hardened and Ground 60 Case Precision LinearRace Shafting

Part Number Description

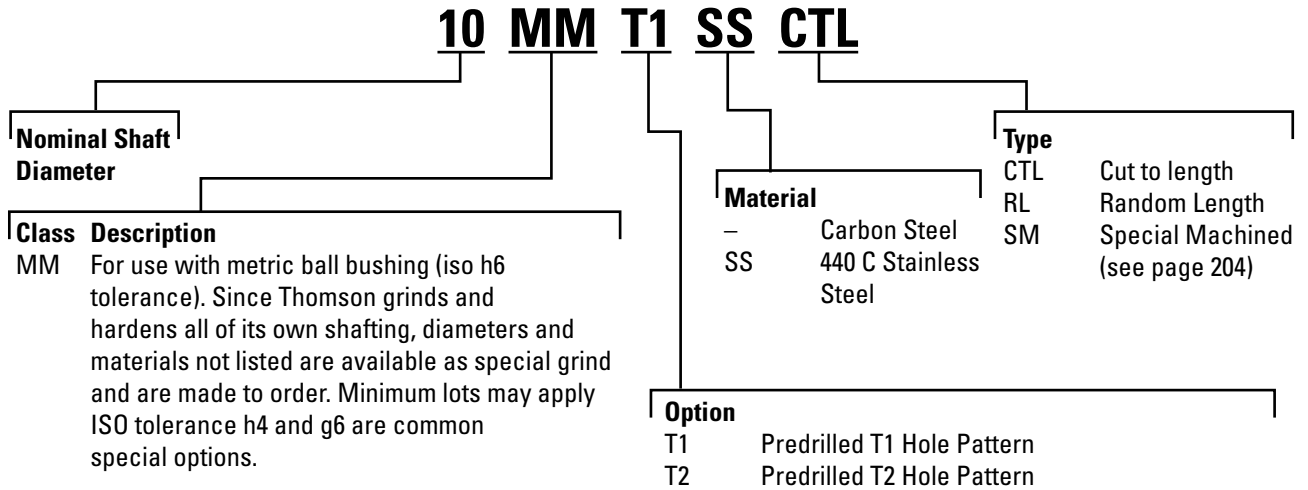

CTL = Cut to length is Thomson 60 Case cut to your specified length.
 RL = Random length is full bar or long length shafting. It is called random length because we start with a raw bar 4" to 6" longer than the minimum usable but guarantee only the minimum visible. We mark the ends of what is out of our own tolerance. This is the result of the manufacturing process and tightly controlled roundness specifications.

Solid Carbon Steel

Hardness: 60 ROCKWELL C Min.
 Surface Finish: 8 Ra Max
 Straightness: .0254mm (.001") Per Foot Cumulative
 (.051mm (.002") TIR)

Roundness: .0020mm (.00080") Class MM
 Taper: .0025mm (.001")

Nominal Diameter (mm)	Basic Part Number	Diameter Tolerance		Min. Usable Length		Min. Hardness Depth		Weight per m (kg)	Weight per inch (lb)
		(mm)	(inch)	(mm)	(inch)	(mm)	(inch)		
5	5 MM	5.00	.1969	1905	54	0.69	0.027	0.16	0.009
		4.99	.1965						
8	8 MM	8.00	.3150	4216	166	0.69	0.027	0.39	0.022
		7.99	.3146						
10	10 MM	10.00	.3937	4216	166	0.69	0.027	0.63	0.035
		9.99	.3932						
12	12 MM	12.00	.4724	4216	166	1.02	0.04	0.89	0.050
		11.99	.4720						
15	15 MM	15.00	.5906	4521	202	1.02	0.04	1.38	0.077
		14.99	.5902						
16	16 MM	16.00	.6299	4521	202	1.02	0.04	1.57	0.088
		15.99	.6295						
20	20 MM	20.00	.7874	4521	202	1.52	0.06	2.47	0.138
		19.99	.7869						
25	25 MM	25.00	.9843	4521	202	2.03	0.08	3.87	0.216
		24.99	.9838						
30	30 MM	30.00	1.1811	4521	202	2.03	0.08	5.57	0.311
		29.99	1.1806						
40	40 MM	40.00	1.5748	4521	202	2.03	0.08	9.90	0.553
		39.99	1.5743						
50	50 MM	50.00	1.9685	4521	202	2.54	0.1	15.46	0.864
		49.98	1.9679						
60	60 MM	60.00	2.3622	4521	202	2.54	0.1	22.19	1.240
		59.98	2.3615						
80	80 MM	80.00	3.1496	5130	202	2.54	0.1	39.55	2.210
		79.97	3.1486						

Standard random length (RL) minimum usable length is 4521mm (178").

Metric - 60 Case Shafting

Standard Options for Carbon Steel Shafting Predrilled (T1 and T2)

Hardness: 60 ROCKWELL C Min.

Surface Finish: 8 Ra Max

Roundness: .0020mm (.00080") Class MM

Straightness: .0254mm (.001") Per Foot Cumulative
(.051mm (.002") TIR)

Taper: .0025mm (.001")

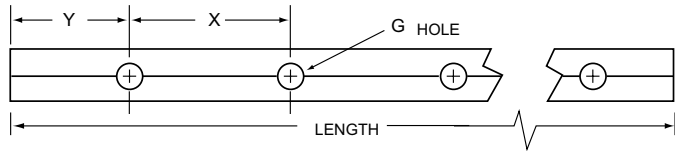

T1 Predrilled

Nominal Diameter (mm)	Basic Part Number	MMT1 Diameter Tolerance		X		G Standard Size	Min. Usable Length		Min. Hardness Depth		Weight Per m (kg)	Weight Per in (lb)
		(mm)	(inch)	(mm)	(inch)		(mm)	(in)	(mm)	(in)		
12	12 MM T1	12.00	0.4724	75	2.953	M4	4216	166	1.02	0.04	0.89	0.050
		11.99	0.4720									
16	16 MM T1	16.00	0.6299	100	3.937	M5	4521	178	1.02	0.04	1.57	0.088
		15.99	0.6295									
20	20 MM T1	20.00	0.7874	100	3.937	M6	4521	178	1.52	0.06	2.47	0.138
		19.99	0.7869									
25	25 MM T1	25.00	0.9843	120	4.724	M8	4521	178	2.03	0.08	3.87	0.216
		24.99	0.9838									
30	30 MM T1	30.00	1.1811	150	5.906	M10	4521	178	2.03	0.08	5.57	0.311
		29.99	1.1806									

Y = distance from end of rail to the center of first mounting hole, Y1 = Y2 unless specified.

T2 Predrilled

Nominal Diameter (mm)	Basic Part Number	MMT1 Diameter Tolerance		X		G Standard Size	Min. Usable Length		Min. Hardness Depth		Weight Per m (kg)	Weight Per in (lb)
		(mm)	(inch)	(mm)	(inch)		(mm)	(in)	(mm)	(in)		
12	12 MM T2	12.00	0.4724	120	4.724	M4	4216	166	1.02	0.04	0.89	0.050
		11.99	0.4720									
16	16 MM T2	16.00	0.6299	150	5.906	M5	4521	178	1.02	0.04	1.57	0.088
		15.99	0.6295									
20	20 MM T2	20.00	0.7874	150	5.906	M6	4521	178	1.52	0.06	2.47	0.138
		19.99	0.7869									
25	25 MM T2	25.00	0.9843	200	7.874	M8	4521	178	2.03	0.08	3.87	0.216
		24.99	0.9838									
30	30 MM T2	30.00	1.1811	200	7.874	M10	4521	178	2.03	0.08	5.57	0.311
		29.99	1.1806									
40	40 MM T2	40.00	1.5748	300	11.811	M10	4521	178	2.03	0.08	9.90	0.553
		39.99	1.5743									

Y = distance from end of rail to the center of first mounting hole, Y1 = Y2 unless specified.

Metric - 60 Case Shafting

440 C Stainless Steel

Hardness: 50 ROCKWELL C Min.

Surface Finish: 8 Ra Max

Straightness: .0254mm (.001") Per Foot Cumulative
(.051mm (.002") TIR)

Roundness: .0020mm (.000080") Class MM

Taper: .0025mm (.001")

Nominal Dia. (mm)	Basic Part Number	Diameter Tolerance		Min. Usable Length		Min. Hardness Depth		Weight Per m (kg)	Weight Per in (lb)
		(mm)	(inch)	(mm)	(in)	(mm)	(in)		
5	5 MM SS	5.00	0.1969	1905	54	0.69	0.027	0.16	0.009
		4.49	0.1965						
8	8 MM SS	8.00	0.3150	4216	178	0.69	0.027	0.39	0.022
		7.99	0.3146						
10	10 MM SS	10.00	.03937	4216	178	0.69	0.027	0.63	0.035
		9.99	0.3932						
12	12 MM SS	12.00	0.4724	4216	178	1.02	0.04	0.89	0.050
		11.99	0.4720						
16	16 MM SS	16.00	0.6299	4521	178	1.02	0.04	1.57	0.088
		15.99	0.6295						
20	20 MM SS	20.00	0.7874	4521	178	1.52	0.06	2.47	0.138
		19.99	0.7869						
25	25 MM SS	25.00	0.9843	4521	178	2.03	0.08	3.87	0.216
		24.99	0.9838						
30	30 MM SS	30.00	1.1811	4521	178	2.03	0.08	5.57	0.311
		29.99	1.1806						
40	40 MM SS	40.00	1.5748	4521	178	2.03	0.08	9.90	0.553
		39.99	1.5743						
50	50 MM SS	50.00	1.9685	4521	178	2.54	0.1	15.46	0.864
		49.98	1.9679						
60	60 MM SS	60.00	2.3622	4521	178	2.54	0.1	22.19	1.240
		59.98	2.3615						

Metric - Support Rails and Support Rail Assemblies

Support Rails and Assemblies for Continuously Supported Applications

Part Number Description

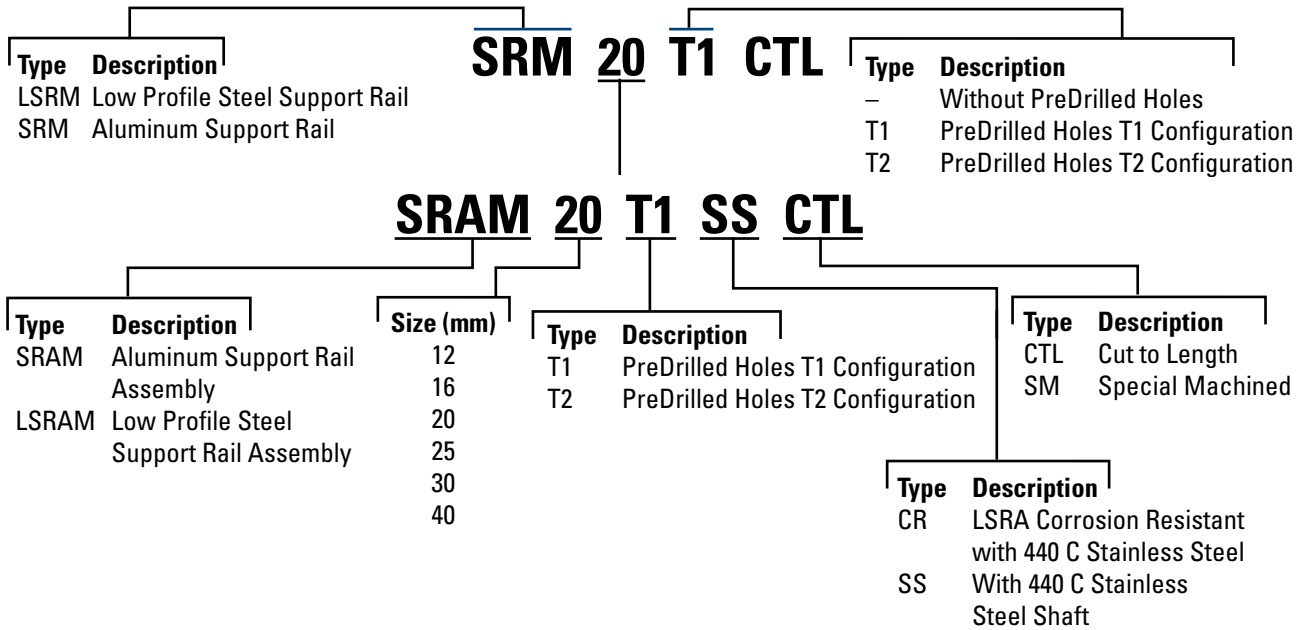

Shaft Rail Supports Type SRM, SRM-T1 & SRM-T2

The low cost way of mounting Thomson 60 Case shafts

Shaft supports simplify mounting of Thomson 60 Case shafts. Users of Thomson 60 Case shafting should carefully consider the use of these low cost shaft supports. They are standard, available from stock, and simplify shaft mounting. In addition to many other benefits, they eliminate many problems encountered in designing and manufacturing shaft supporting devices. These versatile mounts can be used horizontally or vertically, and in many different arrangements. Shaft support rails are available without pre-drilled holes (SR) or pre-drilled (SR-PD) shaft rails to support 12mm to 40mm diameter shafts are available in standard 600mm where shorter lengths are needed, rails are easily cut to length. For longer shafts they can be mounted end to end, using shims or grout, if necessary, to compensate for slight variation within manufacturing tolerance. Thomson offers shaft support rails with pre-drilled holes to simplify shaft mounting.

Metric - Support Rails and Support Rail Assemblies

Low Shaft Support Rails Type LSR, LSR-T2

For compact designs

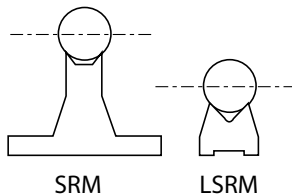

Low Shaft Rails allow the design of more compact linear motion systems. The height from the base to the mean shaft center ranges from 14mm for supporting a 12mm diameter shaft to a maximum 39mm when supporting a 40mm diameter shaft – 40% lower than standard support rails. Low Shaft Rails are made of steel to maintain optimum shaft rigidity. Either continuous or intermittent support is possible when using Thomson open-type linear ball bearings. Low Shaft Rails are furnished in standard 1200mm lengths. Where shorter lengths are required, rails can easily be cut. For supporting longer shafts, rails can be mounted end-to-end without limit. Low Shaft Rails are available without pre-drilled mounting holes (LSRM) or with pre-drilled mounting holes (LSRM-T2) to match Thomson drilled and tapped shafts (T2).

Note: When using LSRM-T2, the attachment bolts are from underneath, so you must have access under your machine base plate. The LSRAM assemblies highlighted below utilize attachment bolts from above. If one of the standard pre-drilled Low Shaft Rails is not appropriate for your design needs, Low Shaft Rails can be custom drilled by Thomson to your specifications. Send a print with all required dimensions, tolerances, and quantities needed to our application engineering team.

Pre-Assembled Shaft Rail Assemblies Type SRAM & LSRAM

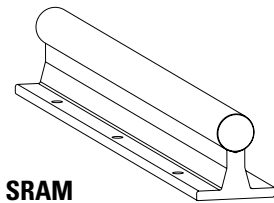

SRAM

Thomson 60 Case steel shafts mounted on shaft support rails are now available for instant bolt-down installation. Assemblies are supplied cut to any length, with no limit on the overall length (long lengths are butt jointed together unless specified otherwise). Either solid or light-weight tubular shafting can be assembled to the standard Thomson support rails, which come with base mounting holes spaced evenly along the overall length of the assembly. The LSRAM uses a special shaft unlike the LSRM-T2. The attachment bolts for the LSRA are from the top down so you can easily mount into a machine base plate. The LSRAM bolt pattern closely matches Profile Rail Linear Guides and can easily be used as a drop-in substitute to replace linear guides (ensure you review loading requirements).

Metric - 60 Case LinearRace Support Rails

60 Case LinearRace Support Rails for Continuously Supported Applications

Type SRM/SRM-PD LinearRace Support Rails and Assemblies (Dimensions in mm)

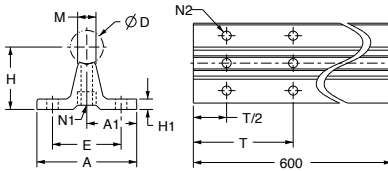

Material: Aluminum Alloy
(Longer Lengths are Available)

Without Holes	With T1 Hole Spacing	With T2 Hole Spacing	D h6	H ±.02	H1	A	A1 ±.02	M	E ±.015	Bolt Hole				Shaft ⁽¹⁾ Rail Mass (kg)
										Spacing		Sizes		
										T1	T2	N1	N2	
SRM12	SRM12 T1	SRM12 T2	12	28	5	43	21.5	9	29	75	120	M4	4.5	1.9
SRM16	SRM16 T1	SRM16 T2	16	30	5	48	24.0	10	33	100	150	M5	5.5	2.8
SRM20	SRM20 T1	SRM20 T2	20	38	6	56	28.0	11	37	100	150	M6	6.6	4.2
SRM25	SRM25 T1	SRM25 T2	25	42	6	60	30.0	14	42	120	200	M8	6.6	5.9
SRM30	SRM30 T1	SRM30 T2	30	53	8	74	37.0	14	51	150	200	M10	8.6	8.7
SRM40	SRM40 T1	SRM40 T2	40	60	8	78	39.0	18	55	200	300	M10	8.6	13.6

N1 Hole Dia. includes counterbore for socket head cap screw. Mounting hole patterns for various sizes. Alignment and location of holes are ± .010, noncumulative.

(1) Standard Length 600mm.

Type LSRM/LSRM-T2 LinearRace Support Rails and Assemblies (Dimensions in mm)

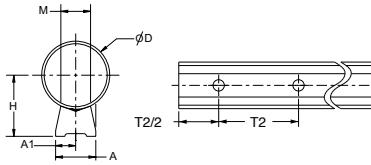

Material: Steel

Without Holes	With T2 Hole Spacing	D h6	H ±.02	A	A1 ±.02	M ±.15	Bolt Hole		Shaft ⁽²⁾ Rail Mass (kg)
							Spacing	Sizes	
							T2	N	
LSRM12	LSRM12 T2	12	14	12	6.0	6.0	120	M4	1.5
LSRM16	LSRM16 T2	16	18	14	7.0	7.0	150	M5	2.4
LSRM20	LSRM20 T2	20	22	17	8.5	8.3	150	M6	3.7
LSRM25	LSRM25 T2	25	26	21	10.5	10.8	200	M8	5.6
LSRM30	LSRM30 T2	30	30	23	11.5	11.0	200	M10	9.0
LSRM40	LSRM40 T2	40	36	23.6	11.8	17.5	300	M12	13.3

(2) Standard Length 1200mm

Type SRAMT1 or SRAMT2 LinearRace Shafting Support Rail Assemblies (Dimensions in mm)

Part Number		d	H ±.02	H1	A	A1 ±.02	M	E ±.015	N1	N2	T1	T2	Mass (kg/m)
SRAM T1 Assembly with LinearRace shafting	SRAM T2 Assembly with LinearRace shafting												
SRAM12 T1	SRAM12 T2	12	28	5	43	21.5	9	29	M4	4.5	75	120	4.06
SRAM16 T1	SRAM16 T2	16	30	5	48	24	10	33	M5	5.5	100	150	6.24
SRAM20 T1	SRAM20 T2	20	38	6	56	28	11	37	M6	6.6	100	150	10.44
SRAM25 T1	SRAM25 T2	25	42	6	60	30	14	42	M8	6.6	120	200	13.69
SRAM30 T1	SRAM30 T2	30	53	8	74	37	14	51	M10	8.6	150	200	20.02
SRAM40 T1	SRAM40 T2	40	60	8	78	39	18	55	M10	8.6	200	300	32.54

Type LSRAM Smart Rail Assemblies (Dimensions in mm)

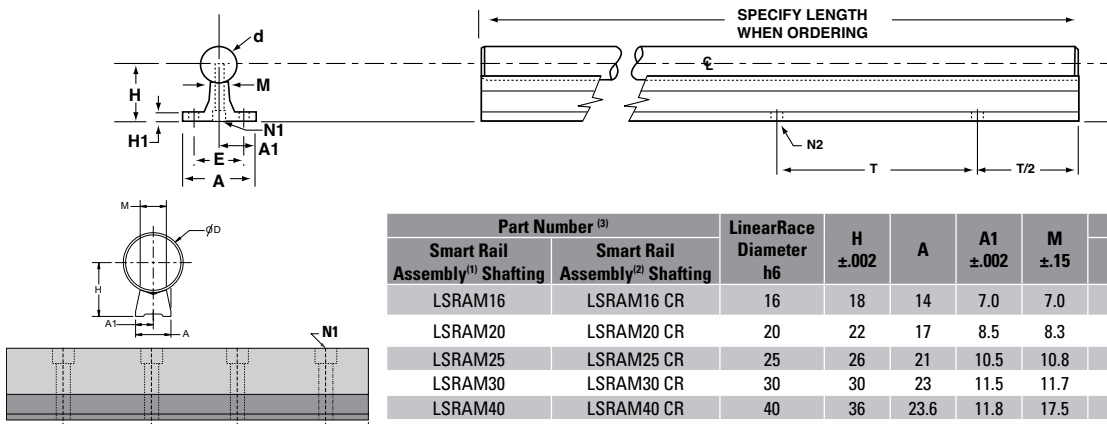

Material: Steel Alloy (Longer Lengths are Available)

Part Number ⁽³⁾		LinearRace Diameter h6	H ±.002	A	A1 ±.002	M ±.15	Bolt Hole		Mass (kg)
Smart Rail Assembly ⁽¹⁾ Shafting	Smart Rail Assembly ⁽²⁾ Shafting						T4	N1	
LSRAM16	LSRAM16 CR	16	18	14	7.0	7.0	40	M3	3.6
LSRAM20	LSRAM20 CR	20	22	17	8.5	8.3	60	M4	5.5
LSRAM25	LSRAM25 CR	25	26	21	10.5	10.8	60	M5	8.5
LSRAM30	LSRAM30 CR	30	30	23	11.5	11.7	80	M6	13.0
LSRAM40	LSRAM40 CR	40	36	23.6	11.8	17.5	105	M10	21.0

(1) = Consists of black oxide steel rail and high carbon steel LinearRace shafting (HRC 60 min.).

(2) = Consists of zinc plated steel rail and 440C stainless steel LinearRace shafting (HRC 50 min.).

(3) = Specify length of Smart Rail when ordering. For example, LSRA M20 x 1200mm.

S dimension is equal on each end unless specified by customer.

Metric - Support Block

Support Block for End Supported Applications

Part Number Description

ASBM 16

Type	Description	Size	mm
ASBM	Low Profile 60 Case LinearRace End Support Block	8	12
SBM	Standard 60 Case LinearRace End Support Block	6	20
		20	25
		30	40

All sizes are not available for all support block types. See specific product charts for size availability.

Shaft Support Blocks – Type SBM and ASBM

For end support or intermittent support

Shaft support blocks are used for end or intermittent support where loads are light and deflection between supports is not a problem. Unlike shaft support rails, blocks do not permit longitudinal passage of open-type Ball Bushing bearings. Type SBM shaft support blocks enable clamping of shafts and eliminate the need for bolts, etc. to maintain shaft position. Shimming is suggested for high precision applications to eliminate the effect of variations in surface of base or manufacturing tolerances between supports.



Type ASBM shaft blocks, manufactured from high strength extruded aluminum, provide either end or intermittent support in applications where loads are designed with a reference edge on one side of the base. This provides a surface parallel to the center of the shaft within $\pm 0.001''$ that can be used to simplify shaft alignment.

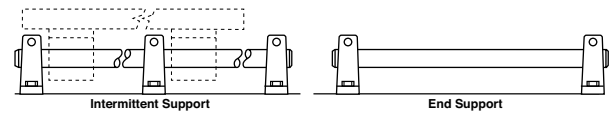

Type ASBM 60 Case LinearRace Shaft End Support Blocks (Dimensions in mm)

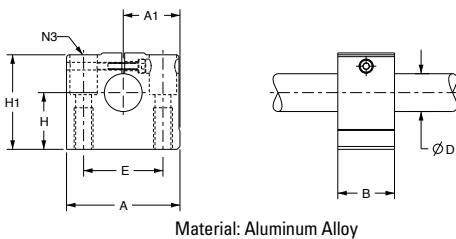

Material: Aluminum Alloy

Part Number	d	H ± 0.001	H1	H2	A	A1 ± 0.012	B	E ± 0.012	N	N2	Support Block Mass (kg)
ASBM08	8	15	28	9	32	16.0	18	22	3.5	M4	0.04
ASBM12	12	20	36	13	43	21.5	20	30	5.3	M6	0.10
ASBM16	16	25	43	18	53	26.5	24	38	6.6	M8	0.15
ASBM20	20	30	51	22	60	30.0	30	42	8.4	M10	0.23
ASBM25	25	35	61	26	78	39.0	38	56	10.5	M12	0.41
ASBM30	30	40	71	26	87	43.5	40	64	10.5	M12	0.53
ASBM40	40	50	88	34	108	54.0	48	82	13.5	M160	0.99

Type SBM 60 Case LinearRace Shaft End Support Blocks (Dimensions in mm)

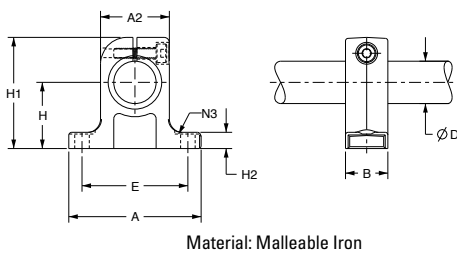

Material: Malleable Iron

Part Number	d	H ± 0.001	H1	H2	A	A1 ± 0.012	B	E ± 0.012	N	Support Block Mass (kg)
SBM08	8	15	27	5.2	32	16	10	25	4.5	0.03
SBM12	12	20	35	5.5	40	21	12	32	5.5	0.06
SBM16	16	25	42	6.5	50	25	16	40	5.5	0.11
SBM20	20	30	50	8.0	60	30	20	45	5.5	0.21
SBM25	25	35	58	9.0	74	37	25	60	6.6	0.35
SBM30	30	40	68	10.0	84	42	28	68	9.0	0.52
SBM40	40	50	86	12.0	108	54	32	86	11.0	0.92

Quick Shaft

Thomson 60 Case Quick Shaft

“Quick shaft” is precut and packaged stock length shafting in popular:

- Inch and metric sizes
- L tolerance class and MM tolerance class
- Materials (carbon steel, 440C stainless steel, lightweight 52100 tubular)
- Standard options (predrilled and chrome plated plain ends)



Thomson 60 Case Quick Shaft can be easily stocked by authorized Thomson distributors or end users.

You may want to have a few pieces of Thomson Quick Shaft in your stock room if you are not sure of the exact length you may need for that potential 3rd shift breakdown or you perform your own special machining of various lengths and do not want to carry different cut to length sizes.

All Thomson Quick Shaft shafting are oil preserved and placed in a VCI bag for long-term storage and labeled for your convenience.

Part Number Description

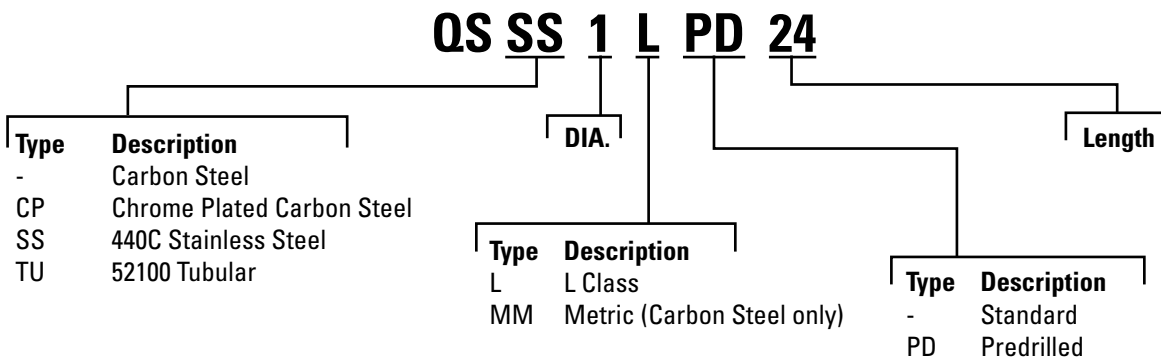

Quick Shaft

60 Case Quick Shaft

Carbon Steel - Inch

Hardness: 60 ROCKWELL C Min.

Surface Finish: 8 Ra Max

Straightness: .001" Per Foot Cumulative

Roundness: .000080"

Taper: .0001"

Part Number	Stock Lengths (in)	Diameter Tolerance (in)	Min. Hardness Depth (in)	Weight Per Inch (lb)
QS 1/4 L	6, 9, 12, 15, 18, 24, 30, 36, 42, 48, 60	.2495	.027	.014
		.2490		
QS 3/8 L	6, 12, 18, 24, 30, 36, 48, 60	.3745	.027	.031
		.3740		
QS 1/2 L	6, 9, 12, 15, 18, 24, 30, 36, 42, 48, 54, 60	.4995	.040	.055
		.4990		
QS 5/8 L	12, 15, 18, 24, 30, 36, 42, 48, 54, 60	.6245	.040	.086
		.6240		
QS 3/4 L	12, 15, 18, 24, 30, 36, 42, 48, 60, 66, 72	.7495	.060	.125
		.7490		
QS 1 L	12, 18, 24, 30, 36, 42, 48, 60, 66, 72	.9995	.080	.222
		.9990		
QS 1 1/4 L	12, 18, 24, 30, 36, 42, 48, 54, 60, 72	1.2495	.080	.348
		1.2490		
QS 1 1/2 L	12, 18, 24, 30, 36, 42, 48, 54, 60, 66, 72	1.4994	.080	.500
		1.4989		
QS 1 3/4 L	12, 18, 24, 30, 36, 42, 48, 60, 72	1.7495	.100	.681
		1.7490		
QS 2 L	12, 18, 24, 30, 36, 42, 48, 60, 72	1.9994	.100	.890
		1.9987		

Carbon Steel - Metric

Hardness: 60 ROCKWELL C Min.

Surface Finish: 8 Ra Max

Straightness: .001" Per Foot Cumulative

Roundness: .000080"

Taper: .0001"

Part Number	Stock Lengths (mm)	Diameter		Min. Hardness Depth		Weight Per m (kg)	Weight Per inch (lb)
		(mm)	(in)	(mm)	(in)		
QS10MM	500,1000	10.00	.3937	.069	.027	0.63	.035
		9.99	.3932				
		12.00	.4724				
QS12MM	250, 500, 750, 1000, 1200, 1500, 2000	11.99	.4720	1.02	.040	0.89	.05
		16.00	.6299				
QS16MM	250, 500, 750, 1000, 1200, 1500, 2000	15.99	.6295	1.02	.040	1.57	.088
		20.00	.7874				
QS20MM	250, 500, 750, 1000, 1200, 1500, 2000	19.99	.7869	1.52	.060	2.33	.13
		25.00	.9843				
QS25MM	500, 750, 1000, 1200, 1500, 2000	24.99	.9838	2.03	.080	3.87	.216
		30.00	1.1811				
QS30MM	500, 750, 1000, 1500, 2000	29.99	1.1806	2.03	.080	5.57	.311
		40.00	1.5748				
QS40MM	500, 750, 1000, 1500, 2000	39.99	1.5743	2.03	.080	9.90	.553

Metric 60 Case Shafting

Quick Shaft

440C Stainless Steel - Inch

Hardness: 50 ROCKWELL C Min.

Surface Finish: 8 Ra Max

Roundness: .000080"

Straightness: .001" Per Foot Cumulative

Taper: .0001"

Part Number	Stock Lengths (in)	Diameter Tolerance (in)	Min. Hardness Depth (in)	Weight Per Inch (lb)
QSSS 1/4 L	6, 12, 18, 24, 30, 36, 48, 60	.2495	.027	.014
		.2490		
QSSS 3/8 L	6, 12, 18, 24, 30, 36, 48, 60	.3745	.027	.031
		.3740		
QSSS 1/2 L	12, 18, 24, 30, 36, 42, 48, 54, 60	.4995	.040	.055
		.4990		
QSSS 5/8 L	12, 18, 24, 30, 36, 42, 48, 54, 60	.6245	.040	.086
		.6240		
QSSS 3/4 L	12, 18, 24, 30, 36, 42, 48, 54, 60, 66, 72	.7495	.060	.125
		.7490		
QSSS 1 L	18, 24, 30, 36, 42, 48, 54, 60, 66, 72	.9995	.080	.222
		.9990		
QSSS 1 1/4 L	12, 18, 24, 30, 36, 42, 48, 54, 60, 72	1.2495	.080	.348
		1.2490		
QSSS 1 1/2 L	18, 24, 30, 36, 42, 48, 54, 60, 66, 72	1.4994	.080	.500
		1.4989		

52100 Tubular - Inch

Hardness: 58 ROCKWELL C Min.

Surface Finish: 8 Ra Max

Roundness: .000080"

Straightness: .001" Per Foot Cumulative

Taper: .0001"

Part Number	Stock Lengths (in)	Nominal I.D.	Diameter Tolerance (in)	Min. Hardness Depth (in)	Weight Per Inch (lb/in)
QSTU 1 L	12, 18, 24, 48, 60	.599 ± 5%	.9995	.080	.158
			.9990		
QSTU 1 1/2 L	12, 18, 24, 48, 60	.890 ± 5%	1.4994	.080	.328
			1.4989		
QSTU 2 L	12, 24, 48, 60	1.250 ± 5%	1.9994	.100	.542
			1.9987		

Quick Shaft

Carbon Steel Predrilled - Inch

Hardness: 60 ROCKWELL C Min.
 Surface Finish: 8 Ra Max
 Straightness: .001" Per Foot Cumulative
 Roundness: .000080"
 Taper: .0001"

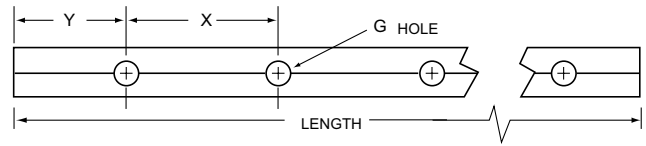

Part Number	Stock Lengths (in)	Diameter Tolerance (in)	X (in)	Y (in)	G Thread Size	Min. Hardness Depth (in)	Weight Per Inch (lb)
QS 1/2 L PD	12, 18, 24, 30, 36, 42, 48, 54, 60, 72	.4995	4	2	#6-32	.040	.055
		.4990					
QS 5/8 L PD	12, 18, 24, 30, 36, 42, 48, 54, 60, 72	.6245	4	2	#8-32	.040	.086
		.6240					
QS 3/4 L PD	12, 18, 24, 30, 36, 42, 48, 54, 60, 72	.7490	6	3	#10-32	.060	.125
		.7485					
QS 1 L PD	18, 24, 30, 36, 42, 48, 54, 60, 72	.9995 .9990	6	3	1/4-20	.080	.222
QS 1 1/4 L PD	18, 24, 30, 36, 42, 48, 54, 60, 72	1.2490	6	3	5/16-18	.080	.348
		1.2485					
QS 1 1/2 L PD	18, 24, 30, 36, 42, 48, 54, 60, 72	1.4994 1.4989	8	4	3/8-16	.080	.500

440C Stainless Steel Predrilled - Inch

Hardness: 50 ROCKWELL C Min.
 Surface Finish: 8 Ra Max
 Roundness: .000080"

Straightness: .001" Per Foot Cumulative
 Taper: .0001"

Part Number	Stock Lengths (in)	Diameter Tolerance (in)	X (in)	Y (in)	G Thread Size	Min. Hardness Depth (in)	Weight Per Inch (lb)
QSSS 1/2 L PD	24, 30, 36, 42, 48, 60, 72	.4995	4	2	#6-32	.040	.055
		.4990					
QSSS 5/8 L PD	24, 30, 36, 42, 48, 54, 60, 72	.6245	4	2	#8-32	.040	.086
		.6240					
QSSS 3/4 L PD	24, 30, 36, 42, 48, 54, 60, 72	.7490	6	3	#10-32	.060	.125
		.7485					
QSSS 1 L PD	18, 24, 30, 36, 42, 48, 54, 60, 72	.9995 .9990	6	3	1/4-20	.080	.222
QSSS 1 1/4 L PD	18, 24, 30, 36, 42, 48, 54, 60, 72	1.2490	6	3	5/16-18	.080	.348
		1.2485					
QSSS 1 1/2 L PD	18, 24, 30, 36, 42, 48, 54, 60, 72	1.4994 1.4989	8	4	3/8-16	.080	.500

Chrome Plated Plain Ends - Inch

Hardness: 60 ROCKWELL C Min.
 Surface Finish: 8 Ra Max
 Straightness: .001" Per Foot Cumulative

Roundness: .000080"
 Taper: .0001"

Part Number	Stock Lengths (in)	Diameter Tolerance (in)	Min. Hardness Depth (in)	Weight Per Inch (lb)
QSCP 1/2 L PD	6, 12, 18, 24, 30, 36, 42, 48, 60	.4995	.040	.055
		.4990		
QSCP 5/8 L PD	12, 18, 24, 30, 36, 42, 48, 54, 60	.6245	.040	.086
		.6240		
QSCP 3/4 L PD	12, 18, 24, 30, 36, 42, 48, 54, 60	.7595	.060	.125
		.7490		
QSCP 1 L PD	12, 18, 24, 30, 36, 42, 48, 54, 60, 72	.9995	.080	.222
		.9990		
QSCP 1 1/4 L PD	18, 24, 30, 36, 42, 48, 54, 60, 66, 72	1.2495	.080	.348
		1.2490		
QSCP 1 1/2 L PD	18, 24, 30, 36, 42, 48, 54, 60, 66, 72	1.4994 1.4989	.080	.500

Special Machining

Special Machining

For over 50 years Thomson has been providing custom special machining on 60 Case Linear Shafting. Our skilled machinists can perform a wide variety of special machining operations on the ends or along the length of the 60 Case Shaft to provide exactly the part needed for your application.

Standard 60 Case shafting, which is available from stock, can be cut with special length tolerances. 60 Case shafting may also be drilled with a variety of radial holes and tapped if needed. Shafts can be supplied with flats, keyways and reduced diameters. Shafts can also be plated.

There is an extra charge for all special machining operations. For specific prices, send your drawing or technical description to Thomson or utilize a copy of the request for quotation and templates found on pages 40-56.

Special Length Tolerances

Standard length tolerance is for $\pm 1/32"$ for shafts less than 2" diameter and $\pm 1/16"$ for 2" diameter and larger. Special length tolerances of $\pm .010"$, $\pm .005"$ and $\pm .002"$ can be achieved on shafts up to 4" in diameter.

Special Straightness Tolerances

Standard straightness is .001" per foot., cumulative (.002" TIR). Special straightness tolerances is .0005" per foot, cumulative (.001" TIR), for all diameters.

Special Chamfer

$1/32"$ x 45° for diameters less than 1" and $1/16"$ x 45° for diameters 1" and larger. Special chamfers at any angle can be supplied for an additional charge.

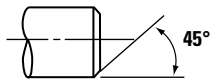

Machining Shaft Ends

For all machining requirements with turned ends, Thomson will anneal the end. The annealing process may cause approximately $1/4"$ to $1/2"$ of heat travel from machined area (depending on major shaft O.D.). Hardness of major shaft diameter near the machined area will be below the Rockwell for the material. If annealing effects are objectionable, alternate machining processes can be used which prevent major diameter softening. Contact factory for special options. (See relevant sections following).

Threaded Shaft Diameter

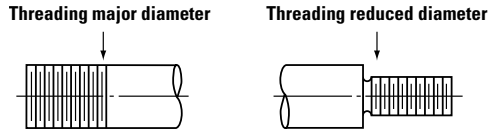

Standard threads are either Unified National Coarse or Unified National Fine, Class 2-A fit. Shafts will be annealed and soft around the circumference of threaded areas within the case.

Reduced Shaft Diameter



Standard diameter tolerance on turned down diameters is $\pm .001"$. Special tolerance of $\pm .0001"$ is available. Runout is within .001" total indicator reading. Shafts are annealed and soft in turned down sections within case. Two-step shaft diameter reduction is also available.

Radial Holes Drilled and Tapped to Center of Shaft

U.N.C. or U.N.F. Class 2-B thread. Tolerances for hole alignment and location are $\pm 1/64"$, $\pm .010"$ and $\pm .005"$.

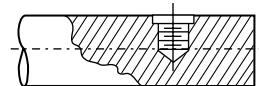

Radial Holes Drilled and Tapped thru Shaft

U.N.C. or U.N.F. Class 2-B thread. Alignment and location tolerance $\pm .010"$ shaft annealed and soft around circumference in hole area.

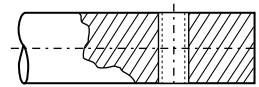

Radial Holes Drilled through Shaft

Alignment and location tolerance $\pm .010"$.

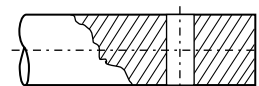

For requests for quotation and ordering custom machined 60 Case LinearRace shafting see the convenient templates on pages 209 through 225.

Special Machining

Radial Holes Drilled and Reamed through Shafts

Alignment and location tolerance $\pm .010"$. Hole diameter tolerance $\pm .001"$. Shaft annealed and soft around circumference in hole area.

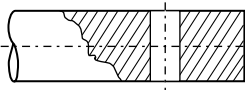

Radial Holes Drilled through Shaft and Counterbored for Cap Screw

Alignment and location tolerance $\pm .010"$. Tolerance for body diameter and head diameter for American Std. cap screw is $+ 1/32"$. Shaft remains hard in hole area (not annealed).

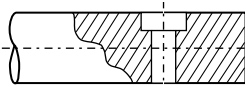

Radial Hole Location Tolerance

Unless specified standard location tolerance between holes is $\pm .1/64"$, optional $\pm .010"$ capability exists for all through hole $\pm .005"$ for hole to center.

Coaxial Holes Drilled and Tapped in Center of End of Shaft

U.N.C. or U.N.F. Class 2-B thread. Concentricity $\pm .005"$. Certain diameters and materials will be annealed and remain soft around the circumference. Note: Holes may also be located on a "bolt" circle. Location tolerance is $.010"$.



Retaining Ring Groove

Location tolerances between grooves $\pm 1/64"$ or $\pm .005"$. Tolerance of $\pm .005"$ for maximum ring groove spacing is $96"$.



Joining Shafts to Obtain Longer Lengths

Threaded and ground joints for $3/4"$ through $4"$ and 20mm thru 80mm diameter shaft for lengths up to 20 feet. Dowled joints with concentricity $\pm .010"$ for $1/2"$ thru $4"$ and 12mm thru 80mm diameter shaft. The feasibility of butted joints should be considered as possibly the most economical solution before considering either of the previous alternatives.

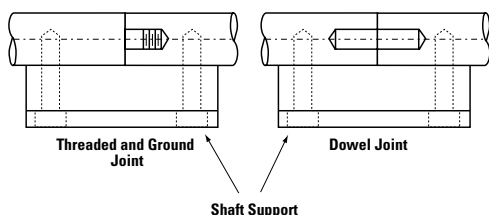

Butted Joints

Ends machined square, no chamfer. Available for all nominal shaft diameters.

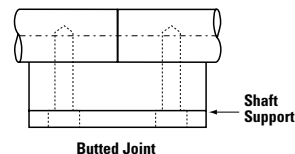

Flats

Flats are available. Flats extending over large portion or entire length of shaft are not available. Cutting into hardened layer would cause considerable warping and subsequent straightening cost is prohibitive.

One Flat on a Shaft

Location tolerance $\pm .015"$.



Multiple Flats on a Shaft

Alignment and location tolerance $\pm .005"$.

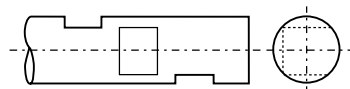

Drilled Spot for Set Screws

Location tolerance $\pm 1/64"$. Capability exists for $\pm .002"$. Drill sizes $1/8"$ thru $3/4"$.

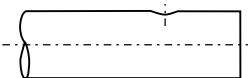

Keyways

Keyways may be square, flat or American Standard Woodruff. Available for nominal shaft diameters from $1/2"$ through $4"$.

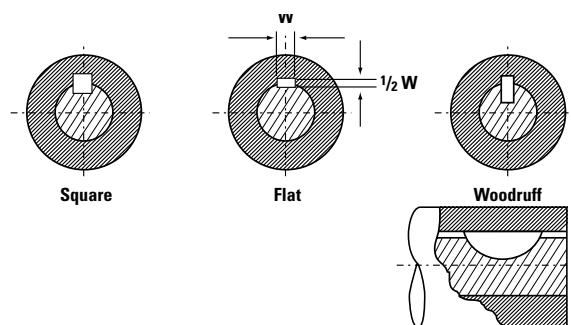

For requests for quotation and ordering custom machined 60 Case LinearRace shafting see the convenient templates on pages 209 through 225.

Special Machining

Example of Our Popular Plating Options

Chrome Plating

The Thomson standard chrome option is pure chrome, with a thickness of .00005" - .0001". (Process per AMS 2460, Class 1 (Corrosion Protective Plating), Type II (Satin finish), but with no nickel underlayer.) Other plating options are available for quote, including, but not limited to Thin Dense Chrome plating per MIL-S-13165 and MIL-R-81841..

As a result of the plating process and the need to hold parts during plating, coaxial holes may be added as follows:

- Up to 1 1/4" diameter shaft any length over 72".
- Over 1 1/4" to 2" diameter shaft any length over 48".
- Over 2" diameter shaft all lengths.

Note: Our CPPE (chrome plated with plain ends) do not have coaxial holes in any length, but the chamfered edges are not plated.

Black Oxide

The benefits of black oxide is corrosion resistance and black color. Military and industrial specifications satisfied with our Black Oxide are Mil-C13924C and AMS-2485.

ARMOLOY™

The benefit of Armoloy™ plating are a 78 RC surface finish, reduction of wear and friction in moving parts, and absolute adhesion to base metal (no chipping, cracking, flaking, or peeling will occur). The Armoloy thickness is .0001". Final plated shaft is within specified tolerance class.

As a result of the plating process and the need to hold parts during plating, coaxial holes may be added as follows:

- Up to 1 1/4" diameter shaft any length over 66".
- Over 1 1/4" all lengths.

Military and industrial specifications satisfied with Armoloy™ plating are AMS-2438, AMS QQ-C-320 and AMS-2406.

Each supplier used for plating has different capabilities to hold the parts, so requirements for coaxial holes may change over time. These should be used as a rule of thumb with an understanding that longer lengths may have coaxial holes. These holes allow the plater to hold the shaft during the plating process. When a coaxial hole is not used it means special tooling is available or the ability exists to pinch the part. If coaxial holes are a problem, please contact us and we can work with our supplier to determine what options exist.

Special Machining

Special Machining Quoting

Thomson will be happy to quote any of your special machining needs. In order for us to properly quote the product, we will require an original product drawing or technical description to be sent to our Application Engineering support team at 1-540-639-4162 (fax). Our Application Engineering team will contact you if they have any questions, require more information, or a better drawing or sketch. This drawing is important to us to ensure we quote exactly what is required at time of quotation instead of when you place your order. Upon ordering, it is important that you reference the quotation number listed at the top right of the quote and have reviewed the entire quotation, including all the notes associated and exceptions to the line item you are ordering. Quantity quoted and price listed is based on one time manufacturing lot quantity not blanket order unless otherwise stated. Thomson reserves the right to requote if quantity ordered is less than quoted quantity. Upon receipt of order, Thomson assumes you have read and understand the quotation and Thomson will assume no responsibility of exceptions on quotation and failure by customer to read.

Our standard quotations are in the format shown below.

QUOTATION

<p>Thomson 203A West Rock Road Radford, VA 24141 USA Phone: 540 633-3400 Fax: 540-639-4162 Email: thomson@thomsonlinear.com</p>	<p>Quote Number 20080XXX Quote Date 01/01/2007 Valid From 01/01/2007 Valid To 01/01/2007</p>
<p>Customer Customer # Customer Name Customer Address Attention Contact Person Phone No. Phone Fax No. Fax</p>	<p>District Manager District Manager's Name 000000000000 Payment Terms Payable 30 days net Delivery Terms FOB from plant</p>

THOMSON IS PLEASED TO SUBMIT THE FOLLOWING QUOTATION
 SUBJECT TO OUR STANDARD TERMS AND CONDITIONS

I am pleased to quote Thomson 60 Case LinearRace shafting, the specified inner race for Thomson Ball Bushing bearings, providing superior smoothness, hardness, and straightness. Use of 60 Case will preserve your bearing warranty and significantly extend life. When used with: Thomson SuperSmart Ball Bushing bearings, shaft life is extended up to five times.

LINE	PART NUMBER	DESCRIPTION	QUANTITY	U/M	UNIT PRICE
FINISH OF 8Ra OR SMOOTHER AND STRAIGHT TO WITHIN .001/.002" PER FOOT CUMULATIVE					
10	7/8 L SM	7/8 L SM X 1.560" Customer Part: PER TEMPLATE	88	EA	16.00

Length 3.500 in.

** SHAFT DIAMETER MAY BE OUT OF TOLERANCE OR DISTORTED ALONG THE LENGTH OF THE 1/2"
COAXIAL BORED HOLE
** BORED HOLE DIAMETER TOLERANCE WILL BE +/- .005"

ESTIMATED SHIPMENT: 3-4 WK

Notes:
1. Quoted lead items are based on current factory backlog and are subject to change.
Please contact Thomson for current lead time.
2. Price is net to Customer Name
3. Price valid for releases through 01/01/2007

If you need any further information, please contact me immediately. Thank You.

Engineer's Name
Applications Engineer

IMPORTANT. QUOTATION NO. MUST APPEAR ON ORDER TO INSURE PROPER BILLING. PRICES QUOTED ARE CONSIDERED FIRM FOR 30 DAYS. Prices apply to quantities of each size released for shipment at one time one destination. No returns or cancellations accepted without consent. The terms and conditions set forth herein shall constitute the entire agreement between the Buyer and the Seller. In the event you receive this information by facsimile only, please refer to our Standard Terms and Conditions appearing on the reverse side of our invoices, quotations, order acknowledgements, and product literature. Any provision or condition of Buyer's order which is in any way different from or in addition to these Standard Terms and Conditions is expressly rejected by Seller unless negotiated as part of this quotation and so noted hereon.

SEE REVERSE SIDE FOR TERMS AND CONDITIONS

Trademark of Thomson Industries Inc. Thomson Industries Inc. is a trademark.
WORLD'S LARGEST MANUFACTURER OF LINEAR BEARINGS AND SHAFTS

Customer Information

Line Item Information

Customer Drawing Number

Noted Item Quoted and Possible Exceptions

Estimated Lead Time

Additional Notes

Engineer who Created Quote

Quotation Number

Quote Date

Validity Period of Quote

Your Thomson Territory Manager

Standard Payment and Delivery Terms

Unit Price

Length

Metric 60 Case Shafting

Special Machining

Request for Quotation

Custom Machined Thomson 60 Case LinearRace Shafting

Customer: _____

Address: _____

City: _____ State: _____ Zip: _____

Contact Name: _____

Phone: _____ Fax: _____

E-mail: _____

Template Number	Quantity
_____	_____
_____	_____
_____	_____
_____	_____
_____	_____

1. Send a copy of your drawing or sketch. If you do not have one, select the Thomson 60 Case LinearRace shaft template that best matches your requirements.

- A. Fill in all available data with tolerances in either inch or metric units.
- B. If a feature is not on the template that you are using, add it, and the applicable dimensions.
- C. If a feature is not required but is on the template, draw a line through the feature, and mark the dimension block with a line or N/A.
- D. Make any additional notes to the template to aid in quoting and manufacturing.

2. Fax this information with the template drawing to: Quotation Department at 1-540-639-4162.

For any questions or help in determining the best solution to your Thomson 60 Case LinearRace shafting requirements, please contact Application Engineering at:

Phone: 1-540-633-3400

E-mail: thomson@thomsonlinear.com

Special Machining

1	2	3	4	F	E	D	C	B	A
<p>STD. MACHINED CHAMFER UNLESS NOTED IN ANGLE 'C' (TYP.)</p>									
<p>LENGTH 'A':</p>									
<p>DIAMETER 'D':</p>									
<p>CLASS:</p>									
<p>ANGLE 'C':</p>									
<p>CHAMFER 'B':</p>									
<p>DEFAULT PRINT TOL: (INCH) FRACTIONS: $\pm 1/32"$.X= $\pm .015"$.HX= $\pm .010"$.HH= $\pm .005"$ ANGLES: $\pm 1/2^\circ$</p>									
<p>DEFAULT PRINT TOL: (METRIC) FRACTIONS: $\pm 1\text{mm}$.X= $\pm .25\text{mm}$.HX= $\pm .13\text{mm}$ ANGLES: $\pm 1/2^\circ$</p>									
<p>CUSTOMER AUTHORIZATION: _____</p>									
<p>MATERIAL: (OTHER MATERIALS AVAILABLE UPON REQUEST) <input type="checkbox"/> 1566 <input type="checkbox"/> 440C <input type="checkbox"/> 52100 TUBING <input type="checkbox"/> OTHER: _____</p>									
<p>PLATING TYPE: _____ APPROVAL _____ DATE _____ DRAWN BY _____ DATE _____</p>									
<p>DO NOT SCALE DRAWING</p>									
<p>TITLES: MACHINED TO LENGTH 60 CASE TEMPLATE 1 DRAWG NO. _____</p>									
<p>THOMSON Linear Motion. Optimized.[™]</p>									

FAX A COPY OF THIS FORM TO QUOTATION DEPARTMENT, THOMSON 1-540-639-4162

Special Machining

1	2	3	4																			
A	B	C	D	E																		
<table border="1" style="width: 100%; border-collapse: collapse;"> <tr><td style="width: 50%;">LENGTH 'A':</td><td style="width: 50%;"></td></tr> <tr><td>DIAMETER 'D':</td><td></td></tr> <tr><td>CLASS</td><td></td></tr> <tr><td>THREAD 'C':</td><td></td></tr> <tr><td>MIN. DEPTH 'E':</td><td></td></tr> <tr><td>THREAD 'F':</td><td></td></tr> <tr><td>MIN. DEPTH 'G':</td><td></td></tr> <tr><td>ANGLE 'H':</td><td></td></tr> <tr><td>CHAMFER 'B':</td><td></td></tr> </table>					LENGTH 'A':		DIAMETER 'D':		CLASS		THREAD 'C':		MIN. DEPTH 'E':		THREAD 'F':		MIN. DEPTH 'G':		ANGLE 'H':		CHAMFER 'B':	
LENGTH 'A':																						
DIAMETER 'D':																						
CLASS																						
THREAD 'C':																						
MIN. DEPTH 'E':																						
THREAD 'F':																						
MIN. DEPTH 'G':																						
ANGLE 'H':																						
CHAMFER 'B':																						
<p>DEFAULT PRINT TOL: (INCH) FRACTIONS: $\pm 1/32"$.H= $\pm 015"$.HH= $\pm 010"$.HHH= $\pm 005"$ ANGLES: $\pm 1/2^\circ$</p>		<p>DEFAULT PRINT TOL: (METRIC) FRACTIONS: $\pm 1mm$.H= $\pm 25mm$.HH= $\pm 13mm$ ANGLES: $\pm 1/2^\circ$</p>																				
CUSTOMER AUTHORIZATION: _____																						
<p>MATERIAL: <input type="checkbox"/> 1566 <input type="checkbox"/> 440C <input type="checkbox"/> 52100 TUBING <input type="checkbox"/> OTHER: _____</p>		<p>(OTHER MATERIALS AVAILABLE UPON REQUEST)</p>																				
<p>PLATING TYPE: _____</p>		<p>APPROVAL DATE DRAWN BY DATE</p>																				
DO NOT SCALE DRAWING																						
<p>THOMSON Linear Motion. Optimized. CO-AXIAL DRILL and TAP 60 CASE TEMPLATE 2 DRUG NO.</p>																						
A	B	C	D	E																		
1	2	3	4	F																		

FAX A COPY OF THIS FORM TO QUOTATION DEPARTMENT, THOMSON 1-540-639-4162

Special Machining

<p>1</p> <p style="text-align: center;">A</p>	<p>2</p> <p style="text-align: center;">B</p>	<p>3</p> <p style="text-align: center;">C</p>	<p>4</p> <p style="text-align: center;">D</p>	<p>5</p> <p style="text-align: center;">E</p>	<p>6</p> <p style="text-align: center;">F</p>
<p>STD. MACHINED CHAMFER UNLESS NOTED IN ANGLE C (TYP.)</p>					
<p>HOLE PATTERN</p>					
<p>LENGTH 'A':</p>					
<p>DIAMETER 'D':</p>					
<p>CLASS:</p>					
<p>THREAD 'E':</p>					
<p>ANGLE 'C':</p>					
<p>CHAMFER 'B':</p>					
<p>LENGTH 'Y1':</p>					
<p>LENGTH 'Y2':</p>					
<p>LENGTH 'X':</p>					
<p>No. of Holes for 'X':</p>					
<p>DEFAULT PRINT TOL: (INCH)</p> <p>FRACTIONS: $\pm 1/32"$</p> <p>.H= $\pm .015"$</p> <p>.HK= $\pm .010"$</p> <p>.HH= $\pm .005"$</p> <p>ANGLES: $\pm 1/2^\circ$</p>		<p>DEFAULT PRINT TOL: (METRIC)</p> <p>FRACTIONS: $\pm 1mm$</p> <p>.H= $\pm .25mm$</p> <p>.HK= $\pm .13mm$</p> <p>ANGLES: $\pm 1/2^\circ$</p>		<p>MATERIAL: (OTHER MATERIALS AVAILABLE UPON REQUEST)</p> <p><input type="checkbox"/> 1566 <input type="checkbox"/> 440C <input type="checkbox"/> 52100 TUBING</p> <p><input type="checkbox"/> OTHER: _____</p>	
<p>CUSTOMER AUTHORIZATION: _____</p>		<p>PLATING TYPE: _____</p>		<p>APPROVAL DATE _____</p>	
<p>_____</p>		<p>DO NOT SCALE DRAWING</p>		<p>DRAWN BY DATE _____</p>	
<p>THOMSON Linear Motion. Optimized.[™]</p>					
<p>TITLE: RADIAL DRILL & TAP 60 CASE TEMPLATE 3</p>					
<p>DRAWG NO. _____</p>					

FAX A COPY OF THIS FORM TO QUOTATION DEPARTMENT, THOMSON 1-540-639-4162

Special Machining

1	2	3	4	F	E	D	C	B	A																		
<table style="width: 100%; border-collapse: collapse;"> <tr> <td style="width: 30%; border-bottom: 1px solid black;">LENGTH 'A':</td> <td style="width: 70%;"></td> </tr> <tr> <td style="border-bottom: 1px solid black;">DIAMETER 'D':</td> <td></td> </tr> <tr> <td style="border-bottom: 1px solid black;">CLASS:</td> <td></td> </tr> <tr> <td style="border-bottom: 1px solid black;">DIAMETER 'C':</td> <td></td> </tr> <tr> <td style="border-bottom: 1px solid black;">MIN. DEPTH 'E':</td> <td></td> </tr> <tr> <td style="border-bottom: 1px solid black;">DIAMETER 'F':</td> <td></td> </tr> <tr> <td style="border-bottom: 1px solid black;">MIN. DEPTH 'G':</td> <td></td> </tr> <tr> <td style="border-bottom: 1px solid black;">ANGLE 'H':</td> <td></td> </tr> <tr> <td style="border-bottom: 1px solid black;">CHAMFER 'B':</td> <td></td> </tr> </table>										LENGTH 'A':		DIAMETER 'D':		CLASS:		DIAMETER 'C':		MIN. DEPTH 'E':		DIAMETER 'F':		MIN. DEPTH 'G':		ANGLE 'H':		CHAMFER 'B':	
LENGTH 'A':																											
DIAMETER 'D':																											
CLASS:																											
DIAMETER 'C':																											
MIN. DEPTH 'E':																											
DIAMETER 'F':																											
MIN. DEPTH 'G':																											
ANGLE 'H':																											
CHAMFER 'B':																											
CUSTOMER AUTHORIZATION: _____			_____																								
DEFAULT PRINT TOL: (INCH) FRACTIONS: ± 1/32" .X= ±.015" .XX= ±.010" .XXX= ±.005" ANGLES: ± 1/2°			DEFAULT PRINT TOL: (METRIC) FRACTIONS: ± 1mm .X= ±.25mm .XX= ±.13mm ANGLES: ± 1/2°																								
MATERIAL:			(OTHER MATERIALS AVAILABLE UPON REQUEST)																								
<input type="checkbox"/> 1566			<input type="checkbox"/> 440C																								
<input type="checkbox"/> OTHER:			<input type="checkbox"/> 52100 TUBING																								
PLATING TYPE:			APPROVAL _____ DATE _____																								
DO NOT SCALE DRAWING			DRAWN BY _____ DATE _____																								
THOMSON Linear Motion. Optimized. CO-AXIAL DRILLED HOLES 60 CASE TEMPLATE 4 DRUG NO. _____																											

FAX A COPY OF THIS FORM TO QUOTATION DEPARTMENT, THOMSON 1-540-639-4162

Special Machining

1	2	3	4	E	F
LENGTH 'A': DIAMETER 'D': CLASS: DIAMETER 'C': LENGTH 'Y': WIDTH 'Y': ANGLE 'F': CHAMFER 'B':		MATERIAL: (OTHER MATERIALS AVAILABLE UPON REQUEST) <input type="checkbox"/> 1566 <input type="checkbox"/> 440C <input type="checkbox"/> 52100 TUBING <input type="checkbox"/> OTHER:			
DEFAULT PRINT TOL: (INCH) FRACTIONS: ± 1/32" .H= ±.015" .HH= ±.010" .HHH= ±.005" ANGLES: ± 1/2°		DEFAULT PRINT TOL: (METRIC) FRACTIONS: ± 1mm .H= ±.25mm .HH= ±.13mm ANGLES: ± 1/2°			
CUSTOMER AUTHORIZATION: _____					
PLATING TYPE: _____			DO NOT SCALE DRAWING		
TITLE: SNAP RING GROOVE 60 CASE TEMPLATE 5					
1	2	3	4	E	F

FAX A COPY OF THIS FORM TO QUOTATION DEPARTMENT, THOMSON 1-540-639-4162

Special Machining

<p>1</p> <p style="text-align: center;">2</p>	<p>3</p>	<p>4</p>
<p>LENGTH 'A':</p> <p>DIAMETER 'D':</p> <p>CLASS:</p> <p>DIAMETER 'C':</p> <p>LENGTH 'G':</p> <p>DIAMETER 'E':</p> <p>LENGTH 'F':</p> <p>ANGLE 'H':</p> <p>CHAMFER 'B':</p>	<p>STD. MACHINED CHAMFER UNLESS NOTED IN ANGLE 'H'</p> <p>.015 RAD. TYP.</p>	<p>DEFAULT PRINT TOL: (INCH) FRACTIONS: ± 1/32" .H= ±.015" .HH= ±.010" .HHH= ±.005" ANGLES: ± 1/2°</p> <p>DEFAULT PRINT TOL: (METRIC) FRACTIONS: ± 1mm .H= ±.25mm .HH= ±.15mm ANGLES: ± 1/2°</p> <p>CUSTOMER AUTHORIZATION: _____</p>
<p>MATERIAL: (OTHER MATERIALS AVAILABLE UPON REQUEST)</p> <p><input type="checkbox"/> 1566 <input type="checkbox"/> 440C</p> <p><input type="checkbox"/> OTHER: _____</p> <p>PLATING TYPE: _____</p> <p>APPROVAL _____ DATE _____</p> <p>DRAWN BY _____ DATE _____</p> <p>DO NOT SCALE DRAWING</p>		<p>TITLE: SHAFT REDUCTION 60 CASE TEMPLATE 6</p> <p>DRAWG NO. _____</p>

FAX A COPY OF THIS FORM TO QUOTATION DEPARTMENT, THOMSON 1-540-639-4162

Special Machining

	<p>STD. MACHINED CHAMFER UNLESS NOTED IN ANGLE 'F' (TYP.)</p> <p>.015 RAD. TYP.</p>	<p>1</p>	<p>2</p>	<p>3</p>	<p>4</p>
<p>LENGTH 'A':</p>	<p>DIAMETER 'D':</p>	<p>CLASS:</p>	<p>DIAMETER 'C':</p>	<p>LENGTH 'E':</p>	<p>ANGLE 'F':</p>
<p>CHAMFER 'B':</p>					
<p>DEFAULT PRINT TOL: (INCH) FRACTIONS: $\pm 1/32"$.H= $\pm .015"$.XX= $\pm .010"$.HHH= $\pm .005"$ ANGLES: $\pm 1/2^\circ$</p>					
<p>DEFAULT PRINT TOL: (METRIC) FRACTIONS: $\pm 1mm$.H= $\pm .25mm$.XX= $\pm .13mm$ ANGLES: $\pm 1/2^\circ$</p>					
<p>MATERIAL:</p> <p><input type="checkbox"/> 1566 <input type="checkbox"/> 440C <input type="checkbox"/> 52100 TUBING</p> <p><input type="checkbox"/> OTHER: _____</p>		<p>(OTHER MATERIALS AVAILABLE UPON REQUEST)</p>		<p>PLATING TYPE:</p> <p>APPROVAL _____ DATE _____</p> <p>DRAWN BY _____ DATE _____</p>	
<p>CUSTOMER AUTHORIZATION: _____</p>					
<p>DO NOT SCALE DRAWING</p>					
<p>TITLE: SHAFT REDUCTION 60 CASE TEMPLATE 7</p>					
<p>DRUG NO.</p>					

FAX A COPY OF THIS FORM TO QUOTATION DEPARTMENT, THOMSON 1-540-639-4162

Special Machining

	<table border="1" style="width: 100%; border-collapse: collapse;"> <tr><td style="padding: 2px;">LENGTH 'A':</td></tr> <tr><td style="padding: 2px;">DIAMETER 'D':</td></tr> <tr><td style="padding: 2px;">CLASS:</td></tr> <tr><td style="padding: 2px;">MIN. KEYWAY LENGTH 'C':</td></tr> <tr><td style="padding: 2px;">WIDTH 'E':</td></tr> <tr><td style="padding: 2px;">KEYWAY DEPTH 'F':</td></tr> <tr><td style="padding: 2px;">ANGLE 'G':</td></tr> <tr><td style="padding: 2px;">CHAMFER 'B':</td></tr> </table>	LENGTH 'A':	DIAMETER 'D':	CLASS:	MIN. KEYWAY LENGTH 'C':	WIDTH 'E':	KEYWAY DEPTH 'F':	ANGLE 'G':	CHAMFER 'B':	<p style="text-align: center;">THOMSON <i>Linear Motion. Optimized.</i></p> <p>TITLE: KEY WAY SLOT 60 CASE TEMPLATE 8</p> <p>DRAWING NO.</p>
LENGTH 'A':										
DIAMETER 'D':										
CLASS:										
MIN. KEYWAY LENGTH 'C':										
WIDTH 'E':										
KEYWAY DEPTH 'F':										
ANGLE 'G':										
CHAMFER 'B':										
	<p>MATERIAL: (OTHER MATERIALS AVAILABLE UPON REQUEST)</p> <p><input type="checkbox"/> 1566 <input type="checkbox"/> 440C <input type="checkbox"/> 52100 TUBING</p> <p><input type="checkbox"/> OTHER:</p>	<p>PLATING TYPE: APPROVAL DATE</p> <p>DO NOT SCALE DRAWING DRAWN BY DATE</p>								
	<p>DEFAULT PRINT TOL: (METRIC)</p> <p>FRACTIONS: ± 1mm .H= ±.25mm .RH= ±.13mm</p> <p>ANGLES: ± 1/2°</p>	<p>DEFAULT PRINT TOL: (INCH)</p> <p>FRACTIONS: ± 1/32" .H= ±.015" .RH= ±.010" .HRH= ±.005"</p> <p>ANGLES: ± 1/2°</p>								
	<p>CUSTOMER AUTHORIZATION: _____</p>									

FAX A COPY OF THIS FORM TO QUOTATION DEPARTMENT, THOMSON 1-540-639-4162

Special Machining

<p>1</p>	<p>2</p>	<p>3</p>	<p>4</p>
<p>A</p>	<p>B</p>	<p>C</p>	<p>D</p>
<p>E</p>	<p>F</p>		

STD. MACHINED CHAMFER UNLESS NOTED IN ANGLE 'F'.

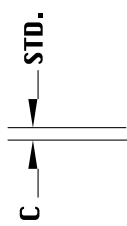
STD.

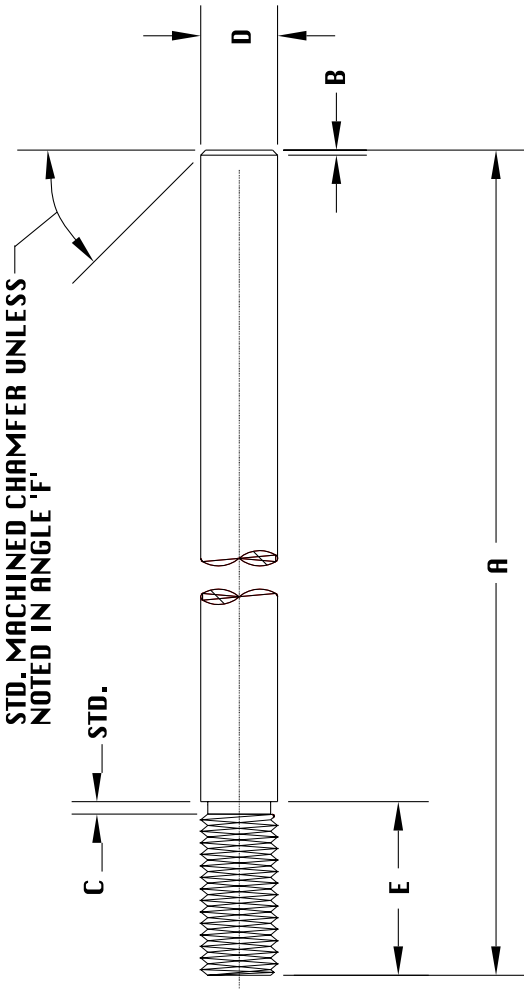

1

LENGTH 'A':	
DIAMETER 'D':	
CLASS:	
THREAD 'C':	
MIN. THREAD LENGTH 'E':	
ANGLE 'F':	
CHAMFER 'B':	

DEFAULT PRINT TOL: (INCH) FRACTIONS: $\pm 1/32"$.R= $\pm .015"$.RR= $\pm .010"$.RRR= $\pm .005"$ ANGLES: $\pm 1/2^\circ$	DEFAULT PRINT TOL: (METRIC) FRACTIONS: $\pm 1mm$.R= $\pm .25mm$.RR= $\pm .13mm$ ANGLES: $\pm 1/2^\circ$	MATERIAL: (OTHER MATERIALS AVAILABLE UPON REQUEST) <input type="checkbox"/> 1566 <input type="checkbox"/> 440C <input type="checkbox"/> 52100 TUBING <input type="checkbox"/> OTHER: _____
CUSTOMER AUTHORIZATION: _____		
PLATING TYPE: _____	APPROVAL _____ DATE _____	DRAWN BY _____ DATE _____
DO NOT SCALE DRAWING		

THOMSON
Linear Motion. Optimized.[™]

TITLE:
**EXTERNAL THREAD
60 CASE TEMPLATE 9**

DRAWING NO. _____

FAX A COPY OF THIS FORM TO QUOTATION DEPARTMENT, THOMSON 1-540-639-4162

Special Machining

1	2	3	4	E	F
<p>STD. MACHINED CHAMFER UNLESS NOTED IN ANGLE 'H'</p> <p>.015 RAD. TYP. STD.</p>					
<p>LENGTH 'A': _____</p> <p>DIAMETER 'D': _____</p> <p>CLASS: _____</p> <p>DIAMETER 'C': _____</p> <p>LENGTH 'G': _____</p> <p>THREAD 'E': _____</p> <p>MIN. THREAD LENGTH 'F': _____</p> <p>ANGLE 'H': _____</p> <p>CHAMFER 'B': _____</p>					
<p>DEFAULT PRINT TOL: (INCH)</p> <p>FRACTIONS: $\pm 1/32$"</p> <p>.H= $\pm .015$"</p> <p>.HH= $\pm .010$"</p> <p>.HHH= $\pm .005$"</p> <p>ANGLES: $\pm 1/2^\circ$</p>			<p>DEFAULT PRINT TOL: (METRIC)</p> <p>FRACTIONS: $\pm 1mm$</p> <p>.H= $\pm .25mm$</p> <p>.HH= $\pm .13mm$</p> <p>ANGLES: $\pm 1/2^\circ$</p>		
<p>CUSTOMER AUTHORIZATION: _____</p>					
<p>MATERIAL: _____ (OTHER MATERIALS AVAILABLE UPON REQUEST)</p> <p><input type="checkbox"/> 1566 <input type="checkbox"/> 440C</p> <p><input type="checkbox"/> OTHER: _____</p>			<p>THOMSON Linear Motion. Optimized.[™]</p> <p>SHAFT REDUCTION with THREAD</p> <p>60 CASE TEMPLATE 10</p> <p>DRUG NO. _____</p>		
<p>PLATING TYPE: _____</p> <p>APPROVAL _____ DATE _____</p> <p>DO NOT SCALE DRAWING</p>			<p>DRAWN BY _____ DATE _____</p>		
A	B	C	D	E	F

FAX A COPY OF THIS FORM TO QUOTATION DEPARTMENT, THOMSON 1-540-639-4162

Special Machining

	<p>STD. MACHINED CHAMFER UNLESS NOTED IN ANGLE 'H' (TYP.)</p> <p>.015 RAD. (TYP.)</p>	<p>LENGTH 'A':</p> <p>DIAMETER 'D':</p> <p>CLASS:</p> <p>DIAMETER 'E':</p> <p>LENGTH 'F':</p> <p>DIAMETER 'C':</p> <p>LENGTH 'G':</p> <p>ANGLE 'H':</p> <p>CHAMFER 'B':</p>	<p>DEFAULT PRINT TOL: (INCH)</p> <p>FRACTIONS: $\pm 1/32"$</p> <p>.R= $\pm .015"$</p> <p>.RR= $\pm .010"$</p> <p>.RRR= $\pm .005"$</p> <p>ANGLES: $\pm 1/2^\circ$</p>	<p>DEFAULT PRINT TOL: (METRIC)</p> <p>FRACTIONS: $\pm 1mm$</p> <p>.R= $\pm .25mm$</p> <p>.RR= $\pm .13mm$</p> <p>ANGLES: $\pm 1/2^\circ$</p>	<p>MATERIAL: (OTHER MATERIALS AVAILABLE UPON REQUEST)</p> <p><input type="checkbox"/> 1566 <input type="checkbox"/> 440C <input type="checkbox"/> 52100 TUBING</p> <p><input type="checkbox"/> OTHER: _____</p>	<p>THOMSON Linear Motion. Optimized.[™]</p> <p>TITLE: SHAFT REDUCTION 60 CASE TEMPLATE 11</p> <p>DRWG NO. _____</p>
<p>PLATING TYPE: _____ APPROVAL _____ DATE _____</p> <p>DO NOT SCALE DRAWING DRAWN BY _____ DATE _____</p>		<p>CUSTOMER AUTHORIZATION: _____</p>		<p>FAX A COPY OF THIS FORM TO QUOTATION DEPARTMENT, THOMSON 1-540-639-4162</p>		

Special Machining

1	2	3	4	F	E	D	C	B	A																
<table border="1" style="width: 100%; border-collapse: collapse;"> <tr> <td style="width: 25%;">LENGTH 'A':</td> <td></td> </tr> <tr> <td>DIAMETER 'D':</td> <td></td> </tr> <tr> <td>CLASS:</td> <td></td> </tr> <tr> <td>DIAMETER 'E':</td> <td style="background-color: black; color: white; text-align: center;">HOLE PATTERN</td> </tr> <tr> <td>DEPTH 'C':</td> <td>LENGTH 'Y1': 'Y2':</td> </tr> <tr> <td>DIAMETER 'F':</td> <td>LENGTH 'X':</td> </tr> <tr> <td>ANGLE 'H':</td> <td>No. of Holes for 'X':</td> </tr> <tr> <td>CHAMFER 'B':</td> <td></td> </tr> </table>										LENGTH 'A':		DIAMETER 'D':		CLASS:		DIAMETER 'E':	HOLE PATTERN	DEPTH 'C':	LENGTH 'Y1': 'Y2':	DIAMETER 'F':	LENGTH 'X':	ANGLE 'H':	No. of Holes for 'X':	CHAMFER 'B':	
LENGTH 'A':																									
DIAMETER 'D':																									
CLASS:																									
DIAMETER 'E':	HOLE PATTERN																								
DEPTH 'C':	LENGTH 'Y1': 'Y2':																								
DIAMETER 'F':	LENGTH 'X':																								
ANGLE 'H':	No. of Holes for 'X':																								
CHAMFER 'B':																									
<p>THOMSON Linear Motion. Optimized.</p>			<p>TITLE: DRILL & COUNTER BORE 60 CASE TEMPLATE 12</p> <p>DRUG NO.</p>				<p>MATERIAL: (OTHER MATERIALS AVAILABLE UPON REQUEST)</p> <p><input type="checkbox"/> 1566 <input type="checkbox"/> 440C</p> <p><input type="checkbox"/> OTHER: _____</p>			<p>PLATING TYPE: _____</p> <p>APPROVAL _____ DATE _____</p> <p>DRAWN BY _____ DATE _____</p> <p>DO NOT SCALE DRAWING</p>															
<p>DEFAULT PRINT TOL: (INCH) FRACTIONS: $\pm 1/32"$</p> <p>.H= $\pm .015"$</p> <p>.RH= $\pm .010"$</p> <p>.RHH= $\pm .005"$</p> <p>ANGLES: $\pm 1/2^\circ$</p>			<p>DEFAULT PRINT TOL: (METRIC) FRACTIONS: $\pm 1mm$</p> <p>.H= $\pm .25mm$</p> <p>.RH= $\pm .13mm$</p> <p>ANGLES: $\pm 1/2^\circ$</p>							<p>CUSTOMER AUTHORIZATION: _____</p>															
<p>FAX A COPY OF THIS FORM TO QUOTATION DEPARTMENT, THOMSON 1-540-639-4162</p>																									

Special Machining

1	2	3	4	E	F
<p>STD. MACHINED CHAMFER UNLESS NOTED IN ANGLE 'E' (TYP)</p>					
<p>LENGTH 'A':</p>					
<p>DIAMETER 'D':</p>					
<p>CLASS:</p>					
<p>DIAMETER 'C':</p>					
<p>LENGTH 'Y':</p>					
<p>ANGLE 'E':</p>					
<p>CHAMFER 'B':</p>					
<p>B (TYP)</p>					
<p>LENGTH 'A':</p>			<p>A</p>		
<p>DIAMETER 'D':</p>			<p>D</p>		
<p>CLASS:</p>			<p>440C</p>		
<p>DIAMETER 'C':</p>			<p>52100 TUBING</p>		
<p>LENGTH 'Y':</p>			<p>OTHER:</p>		
<p>ANGLE 'E':</p>			<p>PLATING TYPE:</p>		
<p>CHAMFER 'B':</p>			<p>APPROVAL _____ DATE _____</p>		
<p>DEFAULT PRINT TOL: (INCH)</p>			<p>DO NOT SCALE DRAWING</p>		
<p>FRACTIONS:</p>			<p>THOMSON <i>Linear Motion. Optimized.</i></p>		
<p>ANGLES:</p>			<p>TITLE:</p>		
<p>CUSTOMER AUTHORIZATION:</p>			<p>THRU PIN HOLE</p>		
<p>DEFAULT PRINT TOL: (METRIC)</p>			<p>60 CASE TEMPLATE 13</p>		
<p>FRACTIONS:</p>			<p>DRAWG NO.</p>		
<p>ANGLES:</p>			<p>DATE _____</p>		

FAX A COPY OF THIS FORM TO QUOTATION DEPARTMENT, THOMSON 1-540-639-4162

Special Machining

	<table border="1" style="width: 100%; border-collapse: collapse;"> <tr> <td style="padding: 2px;">LENGTH 'A':</td> <td style="height: 20px;"></td> </tr> <tr> <td style="padding: 2px;">DIAMETER 'D':</td> <td style="height: 20px;"></td> </tr> <tr> <td style="padding: 2px;">CLASS:</td> <td style="height: 20px;"></td> </tr> <tr> <td style="padding: 2px;">THREAD 'C':</td> <td style="height: 20px;"></td> </tr> <tr> <td style="padding: 2px;">LENGTH 'Y':</td> <td style="height: 20px;"></td> </tr> <tr> <td style="padding: 2px;">ANGLE 'E':</td> <td style="height: 20px;"></td> </tr> <tr> <td style="padding: 2px;">CHAMFER 'B':</td> <td style="height: 20px;"></td> </tr> <tr> <td style="padding: 2px;"> </td> <td style="height: 20px;"></td> </tr> <tr> <td style="padding: 2px;"> </td> <td style="height: 20px;"></td> </tr> </table>	LENGTH 'A':		DIAMETER 'D':		CLASS:		THREAD 'C':		LENGTH 'Y':		ANGLE 'E':		CHAMFER 'B':						<table border="1" style="width: 100%; border-collapse: collapse;"> <tr> <td style="padding: 5px; text-align: center;"> <p>Linear Motion. Optimized.™</p> </td> <td style="padding: 5px;"> MATERIAL: (OTHER MATERIALS AVAILABLE UPON REQUEST) <input type="checkbox"/> 1566 <input type="checkbox"/> 440C <input type="checkbox"/> 52100 TUBING <input type="checkbox"/> OTHER: _____ </td> </tr> <tr> <td style="padding: 5px;"> TITLE: DRILL & TAP 60 CASE TEMPLATE 14 </td> <td style="padding: 5px;"> APPROVAL: _____ DATE: _____ DRAWN BY: _____ DATE: _____ </td> </tr> <tr> <td colspan="2" style="padding: 5px; text-align: center;"> DO NOT SCALE DRAWING </td> </tr> </table>	<p>Linear Motion. Optimized.™</p>	MATERIAL: (OTHER MATERIALS AVAILABLE UPON REQUEST) <input type="checkbox"/> 1566 <input type="checkbox"/> 440C <input type="checkbox"/> 52100 TUBING <input type="checkbox"/> OTHER: _____	TITLE: DRILL & TAP 60 CASE TEMPLATE 14	APPROVAL: _____ DATE: _____ DRAWN BY: _____ DATE: _____	DO NOT SCALE DRAWING	
LENGTH 'A':																										
DIAMETER 'D':																										
CLASS:																										
THREAD 'C':																										
LENGTH 'Y':																										
ANGLE 'E':																										
CHAMFER 'B':																										
<p>Linear Motion. Optimized.™</p>	MATERIAL: (OTHER MATERIALS AVAILABLE UPON REQUEST) <input type="checkbox"/> 1566 <input type="checkbox"/> 440C <input type="checkbox"/> 52100 TUBING <input type="checkbox"/> OTHER: _____																									
TITLE: DRILL & TAP 60 CASE TEMPLATE 14	APPROVAL: _____ DATE: _____ DRAWN BY: _____ DATE: _____																									
DO NOT SCALE DRAWING																										
DEFAULT PRINT TOL: (INCH) FRACTIONS: ± 1/32" .H= ±.015" .HK= ±.010" .HHH= ±.005" ANGLES: ± 1/2°	DEFAULT PRINT TOL: (METRIC) FRACTIONS: ± 1mm .H= ±.25mm .HK= ±.13mm ANGLES: ± 1/2°																									
CUSTOMER AUTHORIZATION: _____																										

FAX A COPY OF THIS FORM TO QUOTATION DEPARTMENT, THOMSON 1-540-639-4162

Special Machining

1	2	3	4	F	E	D	C	B	A									
<table style="width: 100%; border-collapse: collapse;"> <tr> <td style="width: 30%; padding: 5px;">LENGTH 'A':</td> <td style="width: 30%; padding: 5px;">DIAMETER 'D':</td> <td style="width: 30%; padding: 5px;">CLASS:</td> </tr> <tr> <td style="width: 30%; padding: 5px;">LENGTH 'Y':</td> <td style="width: 30%; padding: 5px;">LENGTH 'C':</td> <td style="width: 30%; padding: 5px;">DEPTH 'E':</td> </tr> <tr> <td style="width: 30%; padding: 5px;">ANGLE 'F':</td> <td style="width: 30%; padding: 5px;">CHAMFER 'B':</td> <td style="width: 30%; padding: 5px;"></td> </tr> </table>										LENGTH 'A':	DIAMETER 'D':	CLASS:	LENGTH 'Y':	LENGTH 'C':	DEPTH 'E':	ANGLE 'F':	CHAMFER 'B':	
LENGTH 'A':	DIAMETER 'D':	CLASS:																
LENGTH 'Y':	LENGTH 'C':	DEPTH 'E':																
ANGLE 'F':	CHAMFER 'B':																	
DEFAULT PRINT TOL: (INCH) FRACTIONS: ± 1/32" .H= ±.015" .XX= ±.010" .XXX= ±.005" ANGLES: ± 1/2°			DEFAULT PRINT TOL: (METRIC) FRACTIONS: ± 1mm .H= ±.25mm .XX= ±.13mm ANGLES: ± 1/2°			MATERIAL: (OTHER MATERIALS AVAILABLE UPON REQUEST) <input type="checkbox"/> 1566 <input type="checkbox"/> 440C <input type="checkbox"/> 52100 TUBING <input type="checkbox"/> OTHER: _____				THOMSON Linear Motion. Optimized.™								
CUSTOMER AUTHORIZATION: _____																		
PLATING TYPE: _____			APPROVAL DATE: _____			TITLE: MACHINED SLOTS 60 CASE TEMPLATE 15												
DO NOT SCALE DRAWING																		
DRAWN BY: _____			DATE: _____			DRAWING NO. _____												

FAX A COPY OF THIS FORM TO QUOTATION DEPARTMENT, THOMSON 1-540-639-4162

Special Machining

1	2	3	4		
LENGTH 'A':					
DIAMETER 'D':					
CLASS:					
THREAD 'E':					
HOLE PATTERN					
SPLICE LOCATION(S)					
LENGTH 'Y1': 'Y2': 1)					
LENGTH 'X': 2)					
No. of Holes for 'X': 3)					
ANGLE 'F':					
CHAMFER 'B':					
DEFAULT PRINT TOL: (INCH) FRACTIONS: ± 1/32" .X= ±.015" .XX= ±.010" .XXX= ±.005" ANGLES: ± 1/2°		DEFAULT PRINT TOL: (METRIC) FRACTIONS: ± 1mm .X= ±.25mm .XX= ±.13mm .XXX= ±.075mm ANGLES: ± 1/2°		MATERIAL: (OTHER MATERIALS AVAILABLE UPON REQUEST) <input type="checkbox"/> 1 566 <input type="checkbox"/> 440C <input type="checkbox"/> OTHER: _____	
CUSTOMER AUTHORIZATION: _____		PLATING TYPE: _____ APPROVAL DATE: _____ DRAWN BY DATE: _____		THOMSON Linear Motion. Optimized. TITLE: BUTTED JOINTS 60 CASE TEMPLATE 16 DRUG NO. _____	
DO NOT SCALE DRAWING					
A	B	C	D	E	F

FAX A COPY OF THIS FORM TO QUOTATION DEPARTMENT, THOMSON 1-540-639-4162

Special Machining

1	2	3	4
<p>STD. MACHINED CHAMFER UNLESS NOTED IN ANGLE 'F' (TYP.)</p> <p>STD. RELIEF</p> <p>SPLICE LOCATION(S)</p> <p>SPLICE LOCATION(S)</p> <p>STD. RELIEF</p>			
<p>LENGTH 'A':</p> <p>DIAMETER 'D':</p> <p>CLASS:</p> <p>THREAD 'E':</p> <p>LENGTH 'Y1': 'Y2':</p> <p>LENGTH 'H':</p> <p>No. of Holes for 'H':</p> <p>CHAMFER 'B':</p>			
<p>HOLE PATTERN</p> <p>SPLICE LOCATION(S)</p>			
<p>LENGTH 'Y1': 'Y2':</p> <p>LENGTH 'H':</p> <p>No. of Holes for 'H':</p> <p>CHAMFER 'B':</p>			
<p>DEFAULT PRINT TOL: (INCH) FRACTIONS: ± 1/32" -H= ±.015" -HX= ±.010" -HXX= ±.005" ANGLES: ± 1/2°</p>		<p>DEFAULT PRINT TOL: (METRIC) FRACTIONS: ± 1mm -H= ±.25mm -HX= ±.13mm ANGLES: ± 1/2°</p>	
<p>CUSTOMER AUTHORIZATION:</p>		<p>MATERIAL: (OTHER MATERIALS AVAILABLE UPON REQUEST) <input type="checkbox"/> 1566 <input type="checkbox"/> 440C <input type="checkbox"/> OTHER: _____</p>	
<p>PLATING TYPE: _____</p>		<p>APPROVAL _____ DATE _____ DRAWN BY _____ DATE _____</p>	
<p>DO NOT SCALE DRAWING</p>			
<p>TITLE: DOWEL JOINT 60 CASE TEMPLATE 17</p>			
<p>DRAWING NO. _____</p>			
A	B	C	F

FAX A COPY OF THIS FORM TO QUOTATION DEPARTMENT, THOMSON 1-540-639-4162

RoundRail Linear Guides

RoundRail Linear Guides

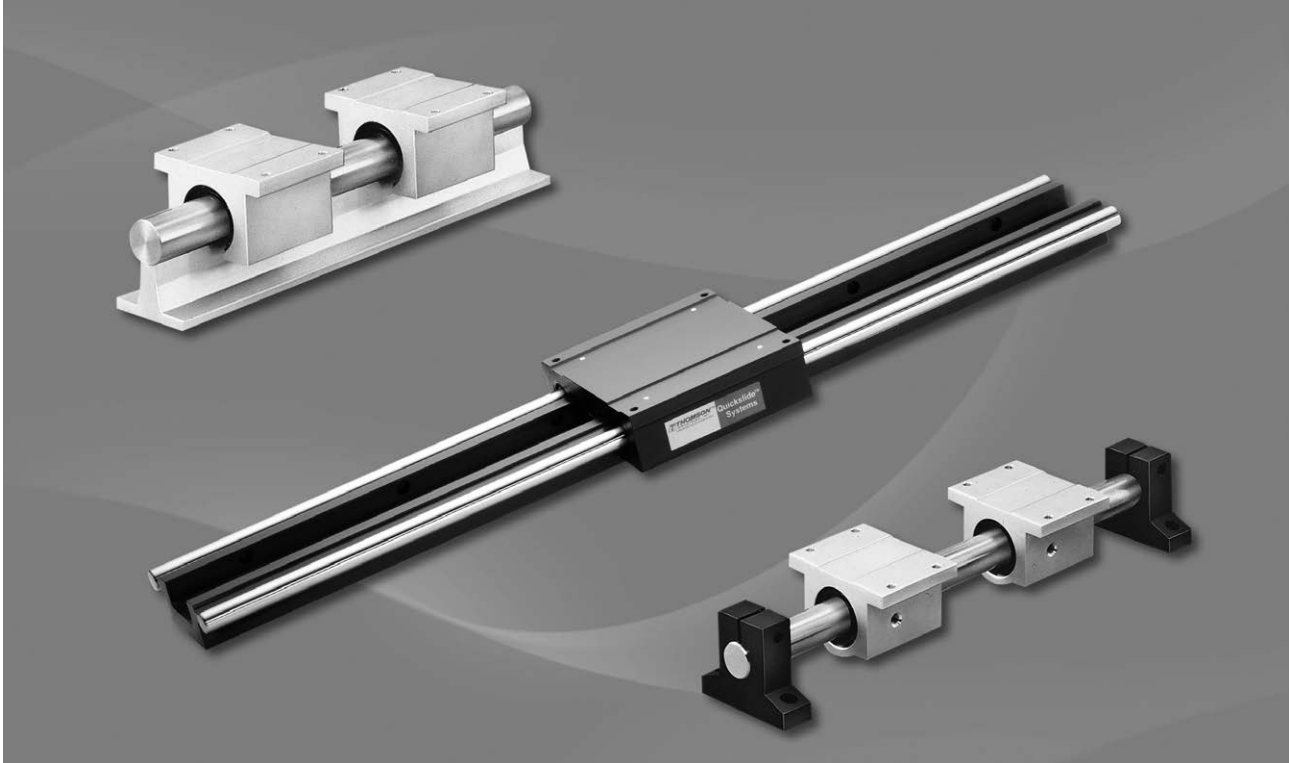

Linear Guides	226 - 260
End Support 1BA.....	237 - 238
End Support 1NA	239 - 240
Continuous Support 1CA	242 - 243
Continuous Support 1PA.....	244 - 245
FluoroNyliner 1VA.....	247 - 248
Side Mounted 1DA.	250 - 251
Dual Shaft Rail 2DA	253 - 254
Twin Shaft Web 2CA.....	255 - 257
Accessories.....	258 - 261

RoundRail Linear Guides are the non-driven building blocks for linear slide tables. They offer the end user flexibility to fit specific envelopes by allowing customized separations between shafts and between bearings on shafts to produce higher moment capacity. When combined with ballscrew assemblies, they become a driven slide table.

Because RoundRail Linear Guides are offered in a wide range of sizes, bearing types, and mounting configurations, they are typically selected by the qualitative attributes that are most appropriate for a given application (i.e. environmental considerations, mounting footprint). For this reason, we are providing the following selection chart and selection criteria for consideration:

Systems Quick Reference Guide

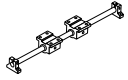
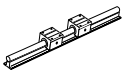
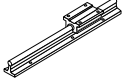
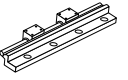
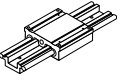
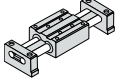
Application Criteria	End Support	Continuous Support	FluoroNyliner	Side Mounted	Dual Shaft Rail	Twin Shaft Web
						
	1BA / 1NA	1 CA / 1PA	1 VA	1 DA	2DA	2CA
High Loads		•	•			
Equivalent Loads in All Directions	•				•	
Ultra Compactness	•					•
Extreme Smoothness	•	•		•		•
End Supported	•				•	•
Single Rail						•
Harsh Environment			•			
Low Cost Installation (multiple rail)	•	•	•	•		
Complete Axis Solution						•
Available Sizes:	Inch	4 thru 24	8 thru 24	8 thru 24	•	•
	Metric	8 thru 40	12 thru 40		8 thru 16	8 thru 16
Page Number	237/239	242/244	247	250	253	256

Linear Guide Selection Criteria

- Load/Life
- Travel Accuracy
- Rigidity
- Smoothness of Travel
- Speed & Acceleration
- Envelope
- Environment
- Cost of Product
- Cost of Installation
- Cost of Replacement

Application Examples

- Machine Tools
- Packaging Machinery
- Automotive Assembly Equipment
- Semiconductor Equipment
- Medical Equipment
- Food Processing Equipment

RoundRail Linear Guides

RoundRail Linear Guides

Thomson RoundRail Linear Guide products offer:

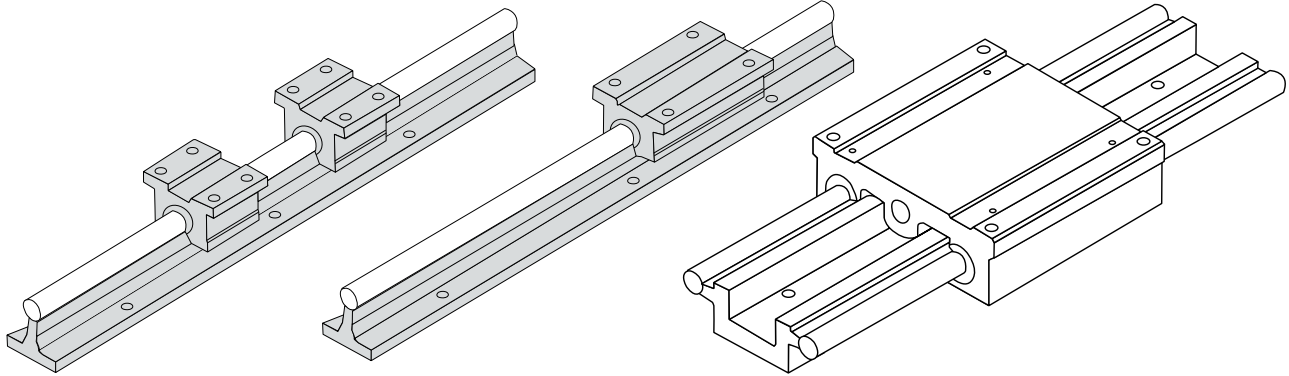

Pre-assembled, ready to install stages providing low friction, smooth, accurate motion for a wide range of moment or normal loading configurations. Market applications include factory automation, medical, packaging, machine tool, semiconductor, printing, automotive assembly, aerospace and food processing. Slide tables are available as customizable linear guides to multi-axis, turnkey systems complete with motors, drives, controls and electromechanical accessories.

- Applications-typically on factory machinery where accurate, smooth linear positioning is required
- Available with servo/stepper motor & drive packages
- Max thrust to 3100 lb
- Strokes to 120"
- Loads from 5 - 2000 lb
- Repeatability to 0.0002"

Linear Guides are the non-driven building blocks for linear slide tables. They offer the end user flexibility to fit specific envelopes by allowing customized separations between shafts and between bearings on shafts to produce higher moment capacity. When combined with ballscrew assemblies, they become a driven slide table.

Because RoundRail Linear Guides are offered in a wide range of sizes, bearing types, and mounting configurations, they are typically selected by the qualitative attributes that are most appropriate for a given application (i.e. environmental considerations, mounting footprint). For this reason, we are providing the following selection chart and selection criteria for consideration:

RoundRail Linear Guide Selection Criteria

- | | | |
|-------------------|------------------------|------------------------|
| • Load/Life | • Smoothness of Travel | • Cost of Product |
| • Travel Accuracy | • Speed & Acceleration | • Cost of Installation |
| • Rigidity | • Envelope | • Cost of Replacement |
| | • Environment | |

Application Examples

- | | |
|---------------------------------|-----------------------------|
| • Machine Tools | • Semiconductor Equipment |
| • Packaging Machinery | • Medical Equipment |
| • Automotive Assembly Equipment | • Food Processing Equipment |

RoundRail Linear Guides

Super Smart Ball Bushing Bearings and Pillow Blocks for End Supported Applications

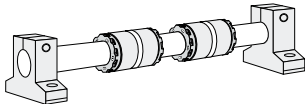

Super Smart Ball Bushing Bearings (Closed Type) Features:

- Available in sizes 1/2 to 1 1/2 inch diameters.
- Load capacity range from 265 to 3,880 lb_r.
- Available with one, two or without integral double lip wipers.
- Can be adjusted to take out diametrical clearance.
- Can be mounted in a customized housing.
- Travel speeds up to 10 ft/s.
- Interchangeable with the industry standard Thomson Super Ball Bushing bearing.

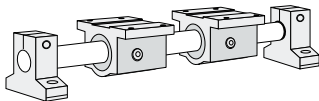

Super Smart Ball Bushing Pillow Blocks (Closed & Adjustable Type) Features:

- Available in sizes 1/2 to 1 1/2 inch diameters.
- Load capacity range from 265 to 3,880 lb_r.
- Available with standard integral double acting seals.
- Available with or without adjustment capability.
- Can be adjusted to take out diametrical clearance.
- Easily mounted and secured with four mounting bolts.
- Travel speeds up to 10 ft/s.
- Available with standard lubrication fitting.
- Interchangeable with the industry standard Thomson Super Ball Bushing Pillow Blocks.

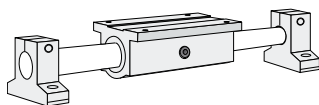

Super Smart Ball Bushing Twin Pillow Blocks (Closed & Adjustable Type) Features:

- Available in sizes 1/2 to 1 1/2 inch diameters.
- Load capacity range from 530 to 7,760 lb_r.
- Available with standard integral double acting seals.
- Available with or without adjustment capability.
- Can be adjusted to take out diametrical clearance.
- Travel speeds up to 10 ft/s.
- Easily mounted and secured with four mounting bolts.
- Available with standard lubrication fitting.
- Interchangeable with the industry standard Thomson Super Ball Bushing Twin Pillow Block.

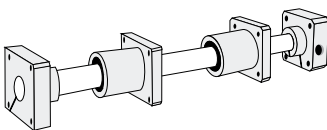

Super Smart Ball Bushing Flanged Single and Twin Pillow Blocks Features:

- Available in sizes 1/2 and 1 1/2 inch diameters.
- Load capacity range from 265 to 7,760 lb_r.
- Available with standard integral double acting seals.
- Without adjustment capability.
- Can be mounted perpendicular to table surface.
- Easily mounted and secured with four mounting bolts.
- Travel speeds up to 10 ft/s.
- Available with standard lubrication fitting.
- Interchangeable with the industry standard Thomson Super Ball Bushing Flanged Single and Twin Pillow Block.

RoundRail Linear Guides

Super Smart Ball Bushing Bearings and Pillow Blocks (Open Type) for Continuously Supported Applications

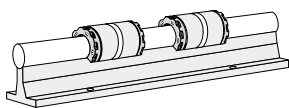

Super Smart Ball Bushing bearing (Open Type) Features:

- Available in sizes 1/2 to 1 1/2 inch diameter.
 - Load capacity range from 360 to 3,880 lb_f.
 - Pull off load capacity range from 250 to 1,750 lb_f.
 - Available with one, two or without double lip integral wipers.
 - Can be adjusted to take out diametrical clearance.
 - Can be mounted in a customized open style pillow block.
 - Travel speeds up to 10 ft/s.
 - Interchangeable with the industry standard Thomson Super Ball Bushing bearing (Open type).
-

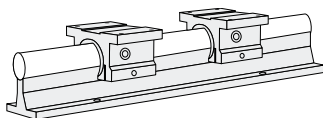

Super Smart Ball Bushing Pillow Blocks (Open Type) Features:

- Available in sizes 1/2 to 1 1/2 inch diameter.
 - Load Capacity range from 360 to 3,880 lb_f.
 - Pull off load capacity range from 250 to 1,750 lb_f.
 - Available with standard double acting integral seals.
 - Can be adjusted to take out diametrical clearance.
 - Easily mounted and secured with four mounting bolts.
 - Travel speeds up to 10 ft/s.
 - Available with standard lubrication access.
 - Interchangeable with the industry standard Thomson Super Ball Bushing Pillow Block (Open Type).
-

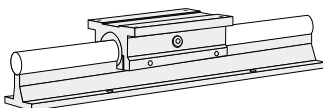

Super Smart Ball Bushing Twin Pillow Blocks (Open Type) Features:

- Available in sizes 1/2 to 1 1/2 inch diameter.
 - Load Capacity range from 720 to 7,760 lb_f.
 - Pull off load capacity range from 500 to 3,500 lb_f.
 - Available with standard double acting integral seals.
 - Can be adjusted to take out diametrical clearance.
 - Easily mounted and secured with four mounting bolts.
 - Travel speeds up to 10 ft/s.
 - Available with standard lubrication access.
 - Interchangeable with the industry standard Thomson Super Ball Bushing Twin Pillow Block (Open Type).
-

RoundRail Linear Guides

Super Ball Bushing Bearings and Pillow Blocks

for End Supported Applications

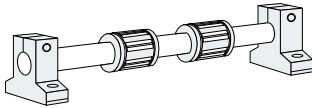

Super Ball Bushing Bearings (Closed type) Features:

- Available in sizes 3/16 to 2 inch diameter.
- Load Capacity range from 35 to 3,000 lb_r.
- Self-aligning in all directions.
- Can be mounted in a custom housing.
- Can be adjusted to take out diametrical clearance.
- Travel speeds up to 10 ft/s.
- Available with corrosion resistant components.

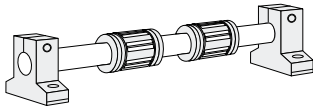

Sealed Super Ball Bushing Bearings (Closed type) Features:

- Integral double acting seals retain lubrication and keep out contamination.
- Available in sizes 1/2, 3/4 and 1 inch nominal diameter.
- Load capacity range from 255 to 1,050 lb_r.
- Self-aligning in all directions.
- Can be adjusted to take out diametrical clearance.
- Can be mounted in a custom housing.
- Travel speeds up to 10 ft/s.
- Available with corrosion resistant components.

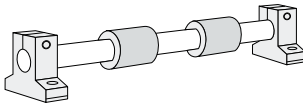

Super Ball Bushing Cartridge Bearings Features:

- Available in sizes 1/4, 3/8 and 1/2 inch diameter.
- Can be easily installed into a soft or slightly out-of-round housing.
- Available in both single or twin versions and with or without integral double acting seals.
- Single versions are self-aligning in all directions.
- Twin versions minimize installation time and cost.
- Available with corrosion resistant components.

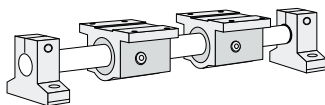

Super Ball Bushing Pillow Blocks (Closed and Adjustable Type) Features:

- Available in sizes 1/4 to 2 inch diameter.
- Load capacity range between 60 and 3,000 lb_r.
- Available with standard integral double acting seals.
- Travel speeds up to 10 ft/s.
- Available with or without diameter adjustment capability.
- Easily mounted and secured with four mounting bolts (sizes 1/4 and 3/8 secured with two mounting bolts).
- Available with a standard lubrication access.

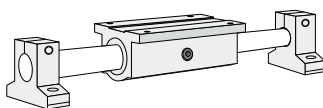

Super Ball Bushing Twin Pillow Blocks (Closed and Adjustable Type) Features:

- Available in sizes 1/4 to 1 1/2 inch diameter.
- Load capacity range between 120 and 4,000 lb_r.
- Available with standard integral double acting seals.
- Travel speeds up to 10 ft/s.
- Available with or without diameter adjustment capability.
- Easily mounted and secured with four mounting bolts.
- Available with a standard lubrication access.

RoundRail Linear Guides

Super Ball Bushing Bearings and Pillow Blocks (Open Type) for Continuously Supported Applications

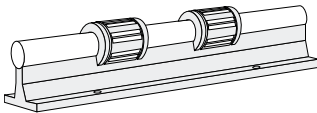

Super Ball Bushing Bearings (Open Type) Features:

- Available in sizes 1/2-2 inch diameter.
- Load capacity ranges from 230 to 2,350 lb_f.
- Self-aligning in all directions.
- Can be adjusted to take out diametrical clearance.
- Can be mounted in customized housing.
- Travel speeds up to 10 ft/s.
- Available with corrosion resistant components.

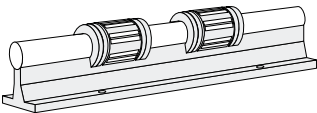

Sealed Super Ball Bushing Bearings (Open Type) Features:

- Standard integral double acting seals retain lubrication and keep out contaminants.
- Available in sizes 1/2, 3/4 and 1 inch diameter.
- Load capacity ranges from 230 to 780 lb_f.
- Self-aligning in all directions.
- Can be adjusted to take out diametrical clearance.
- Can be mounted in customized housing.
- Travel speeds up to 10 ft/s.
- Available with corrosion resistant components.

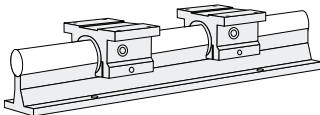

Super Ball Bushing Pillow Blocks (Open Type) Features:

- Available in sizes 1/2-2 inch diameter.
- Load capacity ranges from 230 to 2,350 lb_f.
- Self-aligning in all directions.
- Can be adjusted to take out diametrical clearance.
- Travel speeds up to 10 ft/s.
- Standard integral double acting seals retain lubrication and keep out contaminants.
- Available with corrosion resistant components.
- Easily mounted and secured with four mounting bolts.
- Available with standard lubrication access. Sizes .25, .375 and .500 have oil lubricant fitting. Sizes .625 and above have 1/4-28 access for lubrication.

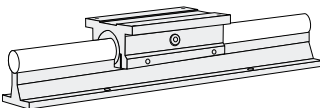

Super Ball Bushing Twin Pillow Blocks (Open Type) Features:

- Available in sizes 1/2-1 1/2 inch diameter.
- Load capacity ranges from 460 to 3,120 lb_f.
- Can be adjusted to take out diametrical clearance.
- Available with corrosion resistant components.
- Standard integral double acting seals retain lubrication and keep out contaminants.
- Easily mounted and secured with four mounting bolts.
- Maximum travel speeds up to 10 ft/s.
- Available with standard lubrication access. Sizes .25, .375 and .500 have oil lubricant fitting. Sizes .625 and above have 1/4-28 access for lubrication.
- Built-in lubrication wick for continuous lubrication.

RoundRail Linear Guides

Precision Steel Ball Bushing Bearings and Pillow Blocks for End Supported Applications

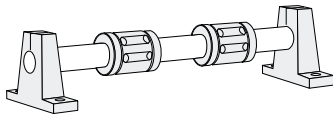
Precision Steel Ball Bushing Bearings (Closed type) Features:

- Coefficient of friction as low as .001.
- Load capacity range from 19 to 5,000 lb_f.
- High operating temperature capability.
- Available in sizes 1/4 to 4 inch bore diameter.
- Can be mounted in a custom housing.
- Travel speeds up to 10 ft/s.
- Available in corrosion resistant stainless steel for diameters up to 1 inch
- All steel construction for increased rigidity.
- Sizes 1/2, 3/4 and 1 inch available with integral, double acting wipers.

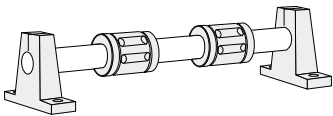
Extra Precision Steel Ball Bushing Bearings (Closed type) Features:

- Increased precision for high accuracy positioning and repeatability
- Coefficient of friction as low as .001.
- Load capacity range from 19 to 5,000 lb_f.
- High operating temperature capability.
- Available in sizes 1/4 to 4 inch bore diameter.
- Can be mounted in a custom housing.
- Travel speeds up to 10 ft/s.
- Available in corrosion resistant stainless steel for diameters up to 1 inch.
- All steel construction for increased rigidity.
- Sizes 1/2, 3/4 and 1 inch available with integral, double acting wipers.

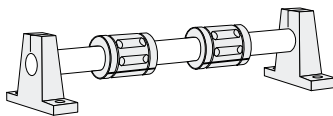
Adjustable Precision Steel Ball Bushing Bearings (Closed Type) Features:

- Adjustment capability provides minimum 60 Case LinearRace shaft and bearing clearance for improvements in positioning accuracy and repeatability.
- Coefficient of friction as low as .001.
- Load capacity range from 85 to 5,000 lb_f.
- High operating temperature capability.
- Available in sizes 1/2 to 4 inch bore diameter.
- Can be mounted in a custom housing.
- Travel speeds up to 10 ft/s.
- All steel construction for increased rigidity.
- Available in corrosion resistant stainless steel for diameters up to 1 inch.

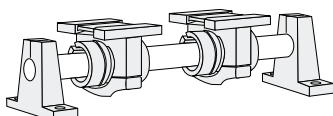
Precision Steel Ball Bushing Pillow Blocks (Closed and Adjustable Type) Features:

- Coefficient of friction as low as .001.
- Load capacity range from 85 to 1,100 lb_f.
- High operating temperature capability.
- Available in sizes 1/2 to 2 inch bore diameter.
- Self-aligning for easy installation.
- Travel speeds up to 10 ft/s.
- Pillow Blocks are available with corrosion resistant stainless steel Ball Bushing bearings up to 1 inch.
- Easily mounted and secured with four mounting bolts.
- All metal construction for increased rigidity.
- Available with integral, double acting seals.
- Adjustment capability provides minimum 60 Case LinearRace and bearing clearance for improvements in positioning accuracy and repeatability.

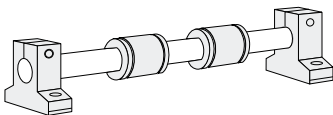
Miniature Instrument Ball Bushing Bearings Features:

- Available in sizes 1/8, 3/16 and 1/4 inch bore diameter.
- Available with a matched 60 Case LinearRace
- Coefficient of friction as low as .001.
- Compact size for low inertia and weight.
- Precision bearing balls, sleeve and 60 Case LinearRace manufactured of corrosion resistant stainless steel.
- Load Capacity range between 7 and 19 lb_f.

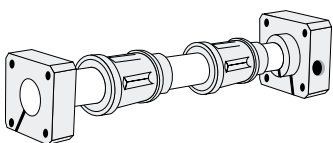
Die Set Ball Bushing Bearings Features:

- Available in sizes 1, 1 1/4, 1 1/2 and 2 inch bore diameter.
- Load Capacity range between 350 and 1,100 lb_f.
- All steel construction for maximum rigidity.
- Travel speeds up to 10 ft/s.
- Easily mounted by simply bolting toe clamps in place.
- Can be mounted perpendicular to mounting surface.
- High operating temperature capability.
- Coefficient of friction as low as .001.

RoundRail Linear Guides

Precision Steel Ball Bushing Bearings and Pillow Blocks (Open Type) for Continuously Supported Applications

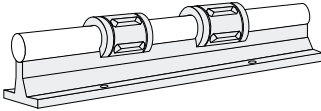

Precision Steel Ball Bushing Bearings (Open type) Features:

- Coefficient of friction as low as .001.
- Load Capacity range from 60 to 3,800 lb_r.
- Can be mounted in a custom housing.
- Available in sizes 1/2 to 4 inch diameter.
- All steel construction for maximum rigidity.
- Can be adjusted to remove clearance between the Ball Bushing bearing and 60 Case LinearRace.
- Available in corrosion resistant stainless steel in sizes up to 1 inch diameter.
- Travel speeds up to 10 ft/s.
- High operating temperature capability.
- Available with corrosion resistant components.

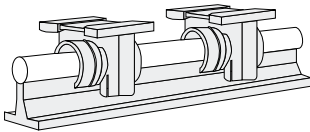

Precision Steel Ball Bushing Bearings and Pillow Blocks (Open type) Features:

- Self-aligning for easy installation.
- Easily secured to table surface with four mounting bolts.
- Coefficient of friction as low as .001.
- Load capacity range from 60 to 860 lb_r.
- Available in sizes 1/2 to 2 inch diameter.
- Available with seals at both ends.
- All steel construction for maximum rigidity.
- Can be adjusted to remove clearance between the Ball Bushing bearing and 60 Case LinearRace.
- Available with corrosion resistant stainless steel Ball Bushing bearing in sizes up to 1 inch diameter.
- Travel speeds up to 10 ft/s.

RoundRail Linear Guides

XR Ball Bushing bearing Products for Continuously Supported Applications

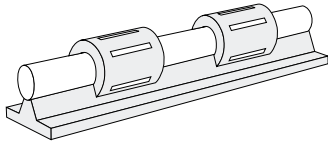

XR Ball Bushing Bearings Features:

- Available in sizes 2 and 3 inch bore diameter.
- Load capacity range from 4,500 to 10,000 lb_f.
- Pull of load capacity range between 2,100 to 8,000 lb_f.
- Can be mounted in a custom housing.
- Travel speeds up to 5 ft/s.
- System accelerations up to 160 ft/s².

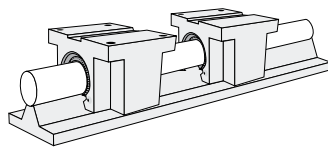

XPBO Ball Bushing Pillow Blocks Features:

- Available in 2 and 3 inch diameter sizes.
- Load capacity range from 4,500 to 10,000 lb_f.
- Pull of load capacity range between 2,100 to 4,500 lb_f.
- Easily secured to table or carriage surface with four mounting bolts.
- Travel speeds up to 5 ft/s.
- System accelerations up to 160 ft/s².
- When used with XL 60 Case LinearRace internal clearance is minimized.
- Integral double acting seals at both ends.

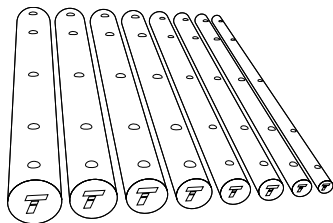

XL 60 Case LinearRace Features:

- Case hardness to 60 HRC minimum.
- Surface finish is 8 Ra microinch for 2 and 3 inch diameter and 10 Ra microinch for 4 inch diameter.
- Roundness 80 millionths of an inch.
- Straightness of .0005 inch per foot (.001 TIR) cumulative.
- Available with standard radial drilled and tapped holes.
- Minimum depth of hardness is .100 inch.

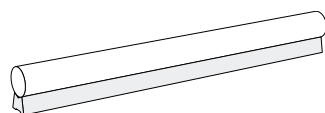

XSR 60 Case LinearRace Support Rails Features:

- All ductile iron, heavy duty design and construction.
- Available in 2 and 3 inch diameter sizes.
- Equipped with drilled thru and counterbored base mounting holes.
- Can be pre-assembled with a 60 Case LinearRace for quick and easy installation.
- Precision ground surfaces for 60 Case LinearRace and base mounting.
- Reference edge for ease of installation.

RoundRail Linear Guides

End Support Linear Ball Guides

**Easy to install, smooth operation,
self-aligning, high speed**

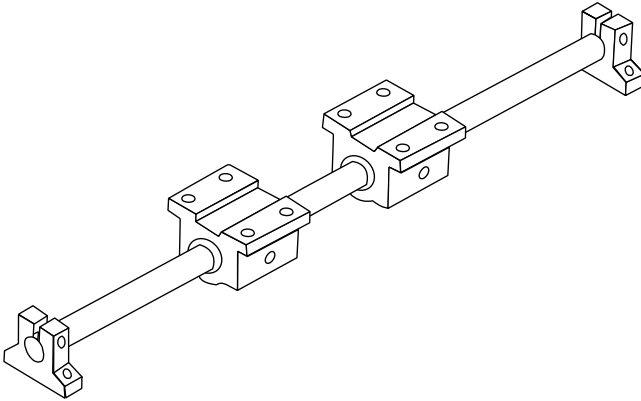

End Support Linear Ball Guides Offer:

- Increased life within the same envelope. RoundRail linear guides feature the new patented Super Smart Ball Bushing Bearings for up to 216X the life or 6X the load capacity of conventional bearings.
- Cost savings: save time and money preparing your mounting surfaces before bolting down RoundRail linear guides
- End supported for gantry style or 'bridge' applications
- The RoundRail Advantage. The inherent self-aligning-in-all-directions design of the Super Smart Ball Bushing bearing allows for ultra smooth travel when mounted to wider toleranced prepared surfaces
- The Super Smart Ball Bushing bearing... the most technologically advanced and most robust linear bearing in the world
- Corrosion resistant versions for maximum performance in harsh environments.

RoundRail Linear Guides

End Support 1BA

End Supported, Industry Standard Dimension Inch

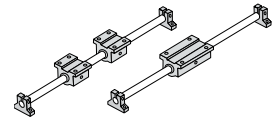

Features

- Requires only one part number to specify entire linear guide.
- Available with 60 Case LinearRace Shaft end support blocks in either light weight aluminum or rigid iron materials
- Used to provide increased stability or torque resistance in linear system applications

Components

- 2 Super Smart Ball Bushing pillow blocks or 1 Super Smart Ball Bushing twin pillow block.
- 1 60 Case LinearRace shaft
- 2 shaft end support blocks

Specifying this Thomson Linear Guide

1. Determine the proper Linear Guide for your load and life requirements.
2. Select the part number.
3. Add the letter "L" followed by the overall length in inches, as a suffix to the part number.

Part Numbering System

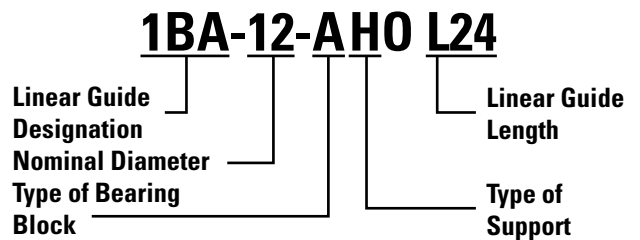

Dimensions (Inch)

Type ASB End Support Block

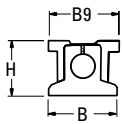

Type SB End Support Block

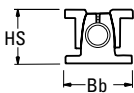

Type SSUPB Super Smart and SPB Super Ball Bushing Pillow Blocks

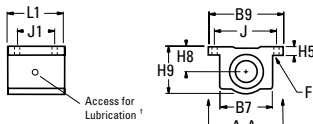

Type SSUTWN Super Smart and TWN Super Ball Bushing Twin Pillow Blocks

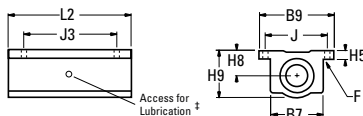

‡ Sizes .250, .375 and .500 have oil lubricant fitting. Sizes .625 and above have 1/4-28 access for lubrication.

Single End Supported Linear Guide with 2 Pillow Blocks

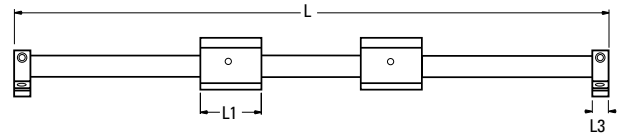

Single End Supported Linear Guide with 1 Twin Pillow Block

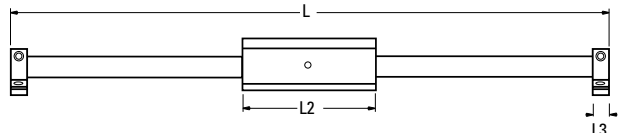

Aluminum

Type ASB LinearRace Shaft End Support Block

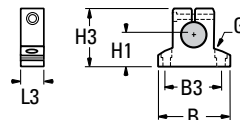

Steel

Type SB LinearRace Shaft End Support Block

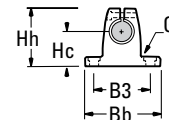

Type SPB Super Ball Bushing Pillow Block Mounting Hole Position for Sizes .250 and .375

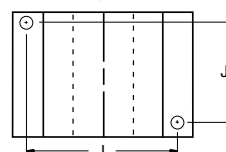

View A-A

RoundRail Linear Guides

End Support Linear Guide 1BA with 2 Pillow Blocks (Dimensions in inches)

Part Number		Nominal Diameter	L1	L3	H	HS	B	Bb	B9	Pillow Block	Shaft Support	
With Type ASB Shaft Supports	With Type SB Shaft Supports										Type ASB	Type SB
1BA-04-AHO	–	.250	1.19	.50	.937	–	1.50	–	1.63	SPB-4-XS	ASB-4-XS	–
1BA-06-AHO	–	.375	1.31	.56	10.62	–	1.63	–	1.75	SPB-6-XS	ASB-6-XS	–
1BA-08-AHO	1BA-08-AJO	.500	1.69	.63	1.562	1.687	2.00	2.00	2.00	SSPB-8-XS	ASB-8-XS	SB-8-XS
1BA-12-AHO	1BA-12-AJO	.750	2.06	.75	2.062	2.187	2.50	2.75	2.75	SSPB-12-XS	ASB-12-XS	SB-12-XS
1BA-16-AHO	1BA-16-AJO	1.000	2.81	1.00	2.562	2.687	3.25	3.25	3.25	SSPB-16-XS	ASB-16-XS	SB-16-XS
–	1BA-20-AJO	1.250	3.63	1.13	–	3.250	–	–	4.00	SSPB-20-XS	–	SB-20-XS
1BA-24-AHO	1BA-24-AJO	1.500	4.00	1.25	3.750	3.750	4.75	4.75	4.75	SSPB-24-XS	ASB-24-XS	SB-24-XS

End Support Linear Guide 1BA with 1 Twin Pillow Block (Dimensions in inches)

Part Number		Nominal Diameter	L2	L3	H	HS	B	Bb	B9	Max Stroke Length	Pillow Block	Shaft Support	
With Type ASB Shaft Supports	With Type SB Shaft Supports											Type ASB	Type SB
1BA-04-BHO	–	.250	2.50	.50	.937	–	1.50	–	1.63	L-(3.50)	TWN-4-XS	ASB-4-XS	–
1BA-06-BHO	–	.375	2.75	.56	10.62	–	1.63	–	1.75	L-(3.88)	TWN-6-XS	ASB-6-XS	–
1BA-08-BHO	1BA-08-BJO	.500	3.50	.63	1.562	1.687	2.00	2.00	2.00	L-(4.75)	SSUTWN-8-XS	ASB-8-XS	SB-8-XS
1BA-12-BHO	1BA-12-BJO	.750	4.50	.75	2.062	2.187	2.50	2.75	2.75	L-(6.00)	SSUTWN-12-XS	ASB-12-XS	SB-12-XS
1BA-16-BHO	1BA-16-BJO	1.000	6.00	1.00	2.562	2.687	3.25	3.25	3.25	L-(8.00)	SSUTWN-16-XS	ASB-16-XS	SB-16-XS
–	1BA-20-BJO	1.250	7.50	1.13	–	3.250	–	–	4.00	L-(9.75)	SSUTWN-20-XS	–	SB-20-XS
1BA-24-BHO	1BA-24-BJO	1.500	9.00	1.25	3.750	3.750	4.75	4.75	4.75	L-(11.50)	SSUTWN-24-XS	ASB-24-XS	SB-24-XS

Shaft Deflection Note: Load limit may be below the dynamic load rating due to shaft deflection. Bearings can accommodate up to 1/2° deflection. See Engineering section (page 275) for Deflection calculations.

Dynamic Load Capacity Matrix (4 million inches travel)

Linear Guide Assembly Part Number	Dynamic Load Capacity (lb _f) (Even Distribution)	Pillow Block Part Number	Pillow Block Dynamic Load Capacity (lb _f)
1BA-04-AHO	100	SPB-4-XS	50
1BA-06-AHO	160	SPB-6-XS	80
1BA-08-AHO 1BA-08-AJO	800	SSPB-8-XS	400
1BA-12-AHO 1BA-12-AJO	1800	SSPB-12-XS	900
1BA-16-AHO 1BA-16-AJO	3000	SSPB-16-XS	1500
– 1BA-20-AJO	3730	SSPB-20-XS	1865
1BA-24-AHO 1BA-24-AJO	6160	SSPB-24-XS	3080

Dynamic Load Capacity Matrix (4 million inches travel)

Linear Guide Assembly Part Number	Dynamic Load Capacity (lb _f) (Even Distribution)	Pillow Block Part Number	Pillow Block Dynamic Load Capacity (lb _f)
1BA-04-BHO	100	TWN-4-XS	100
1BA-06-BHO	160	TWN-6-XS	160
1BA-08-BHO 1BA-08-BJO	800	SSUTWN-8-XS	800
1BA-12-BHO 1BA-12-BJO	1800	SSUTWN-12-XS	1800
1BA-16-BHO 1BA-16-BJO	3000	SSUTWN-16-XS	3000
– 1BA-20-BJO	3730	SSUTWN-20-XS	3730
1BA-24-BHO 1BA-24-BJO	6160	SSUTWN-24-XS	6160

† Super Ball Bushing Bearings are used in .250 and .375 inch size pillow blocks.

Replacement Component Dimensions

Type SPB and SSUPB Pillow Blocks (Dimensions in inches)

Part Number	Nom. Dia.	L1	H9	H8	H5	B9	B7	J	J1	F		Wt. (lb)
										Bolt	Hole	
SPB-4-XS	.250	1.19	.81	.437	.19	1.63	1.00	1.31	.75 ⁽²⁾	#6	.16	.10
SPB-6-XS	.375	1.31	.94	.500	.19	1.75	1.12	1.44	.88 ⁽²⁾	#6	.16	.13
SSPB-8-XS	.500	1.69	1.25	.687	.25	2.00	1.38	1.69	1.00	#6	.16	.20
SSPB-12-XS	.750	2.06	1.75	.937	.31	2.75	1.88	2.38	1.25	#8	.19	.62
SSPB-16-XS	1.000	2.81	2.19	1.187	.38	3.25	2.38	2.88	1.75	#10	.22	1.24
SSPB-20-XS	1.250	3.63	2.81	1.500	.43	4.00	3.00	3.50	2.00	#10	.22	2.57
SSPB-24-XS	1.500	4.00	3.25	1.750	.50	4.75	3.50	4.12	2.50	1/4	.28	3.94

Housing Material: Aluminum Alloy Black Anodized. (2) Two mounting holes as shown in view A-A for sizes .250 and .375. Top plates are sold separately. Please refer to page 260 under Accessories for P/N and dimensions.

Type TWN and SSUTWN Pillow Blocks

Part Number	Nom. Dia.	L2	J3	Wt. (lb)
TWN-4-XS	.25	2.50	2.00	.19
TWN-6-XS	.375	2.75	2.25	.25
SSUTWN-8-XS	.500	3.50	2.50	.40
SSUTWN-12-XS	.750	4.50	3.50	1.24
SSUTWN-16-XS	1.000	6.00	4.50	2.48
SSUTWN-20-XS	1.250	7.50	5.50	5.14
SSUTWN-24-XS	1.500	9.00	6.50	8.08

Housing Material: Aluminum Alloy Black Anodized and

Type ASB LinearRace Shaft End Support Block (Dim. in in.)

Part Number	Nom. Dia.	L3	H3	H1	B	B3	F		Wt. (lb)
							Bolt	Hole	
ASB-4-XS	.250	.50	.88	.500	1.50	1.12	#6	.16	.06
ASB-6-XS	.375	.56	1.00	.562	1.62	1.25	#6	.16	.08
ASB-8-XS	.500	.63	1.48	.875	2.00	1.50	#8	.19	.11
ASB-12-XS	.750	.75	1.95	1.125	2.50	2.00	#10	.22	.22
ASB-16-XS	1.000	1.00	2.48	1.375	3.25	2.50	1/4	.28	.44
ASB-24-XS	1.500	1.25	3.50	2.000	4.75	3.50	5/16	.34	1.16

End Support Material: Aluminum Alloy Black Anodized

Type SB LinearRace Shaft End Support Block (Dim. in in.)

Part Number	Nom. Dia.	L3	Hh	Hc	Bb	B3	F		Wt. (lb)
							Bolt	Hole	
SB-8-XS	.500	.63	1.62	1.000	2.00	1.50	#8	.16	.3
SB-12-XS	.750	.75	2.12	1.250	2.75	2.00	#10	.16	.5
SB-16-XS	1.000	1.00	2.56	1.500	3.25	2.50	1/4	.19	1.0
SB-20-XS	1.250	1.13	3.00	1.750	4.00	3.00	5/16	.22	2.0
SB-24-XS	1.500	1.25	3.50	2.000	4.75	3.50	5/16	.28	2.6

Material: Iron

RoundRail Linear Guides

End Support 1NA

End Supported, Industry Standard Dimension Metric

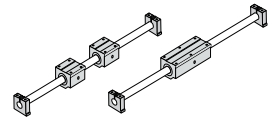

Features

- Requires only one part number to specify entire linear guide.
- Available with 60 Case LinearRace Shaft end support blocks in either light weight aluminum or rigid iron materials
- Used to provide increased stability or torque resistance in linear system applications

Components

- 2 Super Smart Ball Bushing pillow blocks or 1 Super Smart Ball Bushing twin pillow block.
- 1 60 Case LinearRace shaft
- 2 shaft end support blocks

Specifying this Thomson Linear Guide

1. Determine the proper Linear Guide for your load and life requirements.
2. Select the part number.
3. Add the letter "L" followed by the overall length in inches, as a suffix to the part number.

Part Numbering System

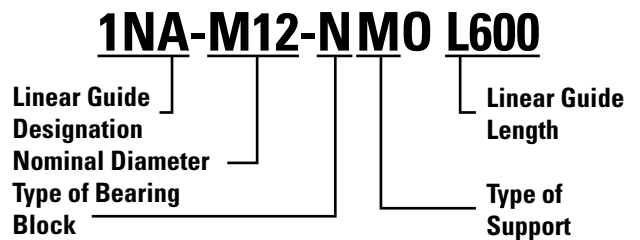

Dimensions (Inch)

Type ASB End Support Block

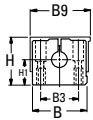

Type SB End Support Block

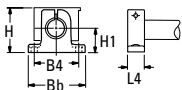

Type SPPB Super Plus and SSEPB Super Smart Ball Bushing Pillow Blocks

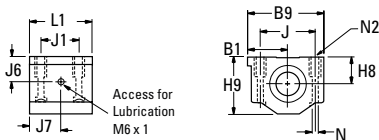

Type SPTWN Super Plus and SSETWN Super Smart Ball Bushing Twin Pillow Blocks

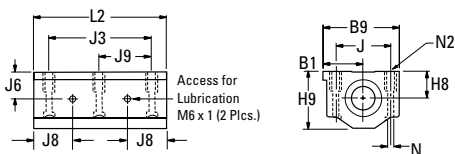

Supported Linear Guide with 2 Pillow Blocks

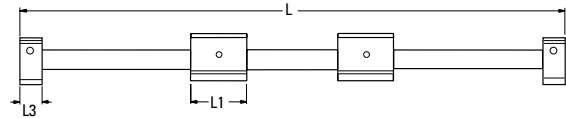

Supported Linear Guide with 1 Twin Pillow Block

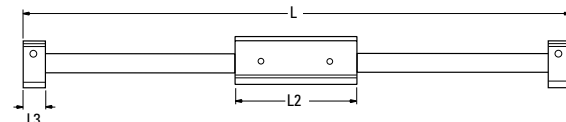

Maximum Stroke Length is determined by subtracting pillow block length (L2) and 2x support block length (L3) or (L4) from total Linear Guide length (L).

Aluminum

Type ASB LinearRace Shaft End Support Block

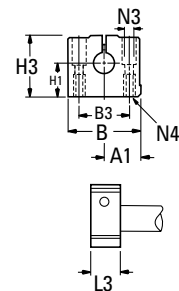

Steel

Type SB LinearRace Shaft End Support Block

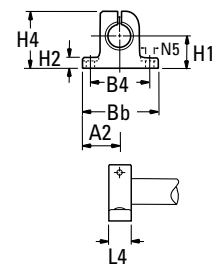

RoundRail Linear Guides

End Support Linear Guide 1NA with 2 Pillow Blocks (Dimensions in mm)

Part Number		Nom. Dia.	L1	L3	L4	H	H1	B	Bb	B9	Pillow Block	Shaft Support	
With Type ASB Shaft Supports	With Type SB Shaft Supports											Type ASB	Type SB
1NA-M08-NMO	1NA-M08-NN0	8	32	18	10	30	15	32	32	35	SPPB-M08-XS	ASB-M08-XS	SB-M08-XS
1NA-M12-NMO	1NA-M12-NN0	12	39	20	12	38	20	43	42	43	SSEPBM12-XS	ASB-M12-XS	SB-M12-XS
1NA-M16-NMO	1NA-M16-NN0	16	43	24	16	47	25	43	50	53	SSEPBM16-XS	ASB-M16-XS	SB-M16-XS
1NA-M20-NMO	1NA-M20-NN0	20	54	30	20	55	30	60	60	60	SSEPBM20-XS	ASB-M20-XS	SB-M20-XS
1NA-M25-NMO	1NA-M25-NN0	25	67	38	25	65	35	78	74	78	SSEPBM25-XS	ASB-M25-XS	SB-M25-XS
1NA-M30-NMO	1NA-M30-NN0	30	79	40	28	75	40	87	84	87	SSEPBM30-XS	ASB-M30-XS	SB-M30-XS
1NA-M40-NMO	1NA-M40-NN0	40	91	48	32	95	50	108	108	108	SSEPBM40-XS	ASB-M40-XS	SB-M40-XS

End Support Linear Guide 1NA with 1 Twin Pillow Block (Dimensions in mm)

Part Number		Nom. Dia.	L2	L3	L4	H	H1	B	Bb	B9	Pillow Block	Shaft Support	
With Type ASB Shaft Supports	With Type SB Shaft Supports											Type ASB	Type SB
1NA-M08-PMO	1NA-M08-PNO	8	62	18	10	30	15	32	32	35	SPTWN-M08-XS	ASB-M08-XS	SB-M08-XS
1NA-M12-PMO	1NA-M12-PNO	12	76	20	12	38	20	43	42	43	SSETWN-M12-XS	ASB-M12-XS	SB-M12-XS
1NA-M16-PMO	1NA-M16-PNO	16	84	24	16	47	25	43	50	53	SSETWN-M16-XS	ASB-M16-XS	SB-M16-XS
1NA-M20-PMO	1NA-M20-PNO	20	104	30	20	55	30	60	60	60	SSETWN-M20-XS	ASB-M20-XS	SB-M20-XS
1NA-M25-PMO	1NA-M25-PNO	25	130	38	25	65	35	78	74	78	SSETWN-M25-XS	ASB-M25-XS	SB-M25-XS
1NA-M30-PMO	1NA-M30-PNO	30	152	40	28	75	40	87	84	87	SSETWN-M30-XS	ASB-M30-XS	SB-M30-XS
1NA-M40-PMO	1NA-M40-PNO	40	176	48	32	95	50	108	108	108	SSETWN-M40-XS	ASB-M40-XS	SB-M40-XS

Shaft Deflection Note: Load limit may be below the dynamic load rating due to shaft deflection. Bearings can accommodate up to 1/2° deflection. See Engineering section (page 275) for Deflection calculations.

Dynamic Load Capacity Matrix (100 km travel)

Linear Guide Assembly Part Number		Dynamic Load Capacity (lb.) (Even Distribution)	Pillow Block Part Number	Pillow Block Dynamic Load Capacity (lb.)
1NA-M08-NMO	1NA-M08-NN0	100	SPPB-M08-XS	50
1NA-M12-NMO	1NA-M12-NN0	160	SSEPBM12-XS	80
1NA-M16-NMO	1NA-M16-NN0	800	SSEPBM16-XS	400
1NA-M20-NMO	1NA-M20-NN0	1800	SSEPBM20-XS	900
1NA-M25-NMO	1NA-M25-NN0	3000	SSEPBM25-XS	1500
1NA-M30-NMO	1NA-M30-NN0	3730	SSEPBM30-XS	1865
1NA-M40-NMO	1NA-M40-NN0	6160	SSEPBM40-XS	3080

Dynamic Load Capacity Matrix (100 km travel)

Linear Guide Assembly Part Number		Dynamic Load Capacity (lb.) (Even Distribution)	Pillow Block Part Number	Pillow Block Dynamic Load Capacity (lb.)
1NA-M08-PMO	1NA-M08-PNO	100	SPTWN-M08-XS	100
1NA-M12-PMO	1NA-M12-PNO	160	SSETWN-M12-XS	160
1NA-M16-PMO	1NA-M16-PNO	800	SSETWN-M16-XS	800
1NA-M20-PMO	1NA-M20-PNO	1800	SSETWN-M20-XS	1800
1NA-M25-PMO	1NA-M25-PNO	3000	SSETWN-M25-XS	3000
1NA-M30-PMO	1NA-M30-PNO	3730	SSETWN-M30-XS	3730
1NA-M40-PMO	1NA-M40-PNO	6160	SSETWN-M40-XS	6160

† Super Plus Ball Bushing Bearings are used in 8 mm size pillow blocks.

Replacement Component Dimensions

Type SPB and SSUPB Pillow Blocks (Dimensions in mm)

Part Number	Nom. Dia.	L1	H9	H8	H5	B9	B7	J	J1	F		Wt. (lb)
										Bolt	Hole	
SPPB-M08-XS	.250	1.19	.81	.437	.19	1.63	1.00	1.31	.75 ⁽²⁾	#6	.16	.10
SSEPBM12-XS	.375	1.31	.94	.500	.19	1.75	1.12	1.44	.88 ⁽²⁾	#6	.16	.13
SSEPBM16-XS	.500	1.69	1.25	.687	.25	2.00	1.38	1.69	1.00	#6	.16	.20
SSEPBM20-XS	.750	2.06	1.75	.937	.31	2.75	1.88	2.38	1.25	#8	.19	.62
SSEPBM25-XS	1.000	2.81	2.19	1.187	.38	3.25	2.38	2.88	1.75	#10	.22	1.24
SSEPBM30-XS	1.250	3.63	2.81	1.500	.43	4.00	3.00	3.50	2.00	#10	.22	2.57
SSEPBM40-XS	1.500	4.00	3.25	1.750	.50	4.75	3.50	4.12	2.50	1/4	.28	3.94

Housing Material: Aluminum Alloy Grey Anodized.

Top plates are sold separately. Please refer to page 260 under Accessories.

Type TWN and SSUTWN Pillow Blocks

Part Number	Nom. Dia.	L2	J3	Wt. (lb)
SSETWN-M12-XS	.375	2.75	2.25	.25
SSETWN-M16-XS	.500	3.50	2.50	.40
SSETWN-M20-XS	.750	4.50	3.50	1.24
SSETWN-M25-XS	1.000	6.00	4.50	2.48
SSETWN-M30-XS	1.250	7.50	5.50	5.14
SSETWN-M40-XS	1.500	9.00	6.50	8.08

Housing Material: Aluminum Alloy Black Anodized

Type ASB LinearRace Shaft End Support Block (Dim. in mm)

Part Number	Nom. Dia.	A1	B	B3	H1	H3	L3	N3 Bolt	N4	Mass (kg)
ASB-M08-XS	8	16,0	32	22	15	28	18	3,5	M4	0,04
ASB-M12-XS	12	21,5	43	30	20	36	20	5,3	M6	0,10
ASB-M16-XS	16	26,5	53	38	25	43	24	6,6	M8	0,15
ASB-M20-XS	20	30,0	60	42	30	51	30	8,4	M10	0,23
ASB-M25-XS	25	39,0	78	56	35	61	38	10,5	M12	0,41
ASB-M30-XS	30	43,5	87	64	40	71	40	10,5	M12	0,53
ASB-M40-XS	40	54,0	108	82	50	88	48	13,5	M16	0,99

End Support Material: Aluminum Alloy Grey Anodized

Type SB LinearRace Shaft End Support Block (Dim. in mm)

Part Number	Nom. Dia.	A2	B4	Bb	H1	H2	H4	L4	N5 Dia.	Mass (kg)
SB-M08-XS	8	16	25	32	15	5,2	27	10	4,5	0,03
SB-M12-XS	12	21	32	42	20	5,5	35	12	5,5	0,06
SB-M16-XS	16	25	40	50	25	6,5	42	16	5,5	0,11
SB-M20-XS	20	30	45	60	30	8,0	50	20	5,5	0,21
SB-M25-XS	25	37	60	74	35	9,0	58	25	6,6	0,35
SB-M30-XS	30	42	68	84	40	10,0	68	28	9,0	0,52
SB-M40-XS	40	54	86	108	50	12,0	86	32	11,0	0,92

End Support Material: Iron

RoundRail Linear Guides

Continuous Support Linear Ball Guides

**High speed, smooth operation,
easy to install**

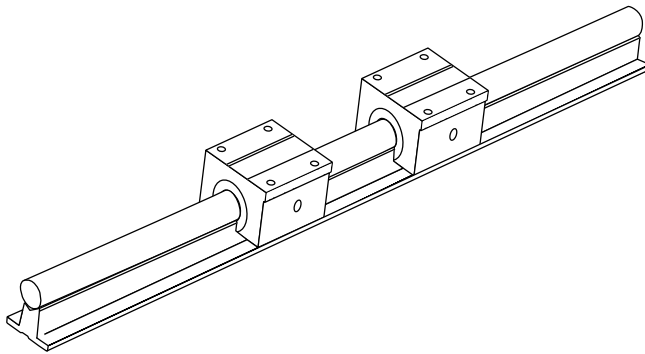

Continuous Support Linear Ball Guides Offer:

- Increased life within the same envelope. RoundRail linear guides feature the new patented Super Smart Ball Bushing Bearings for up to 216X the life or 6X the load capacity of conventional bearings.
- Cost savings: save time and money preparing your mounting surfaces before bolting down RoundRail linear guides
- Superior performance. Continuously supported for maximum (down- & side-) load applications without concerns for shaft deflection
- The RoundRail Advantage. The inherent self-aligning-in-all-directions design of the Super Smart Ball Bushing bearing allows for ultra smooth travel when mounted to wider toleranced prepared surfaces
- Unlimited travel lengths without concerns for machined reference edges or butt joint alignment
- The Super Smart Ball Bushing bearing... the most technologically advanced and most robust linear bearing in the world

RoundRail Linear Guides

Continuous Support 1CA

Fully Supported, Highest Performance, Industry Standard Dimension Inch

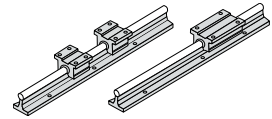

Features

- Requires only one part number to specify the entire linear guide
- Used as a load support, transport, and guidance solution
- Used in continuously supported applications when rigidity is required

Components

- 2 Super Smart Ball Bushing open type pillow blocks or 1 Super Smart Ball Bushing open twin pillow blocks
- 1 60 Case LinearRace shaft support rail assembly

Specifying this Thomson Linear Guide

1. Determine the proper Linear Guide for your load and life requirements.
2. Select the part number.
3. Add the letter "L" followed by the overall length in inches, as a suffix to the part number.

Part Numbering System

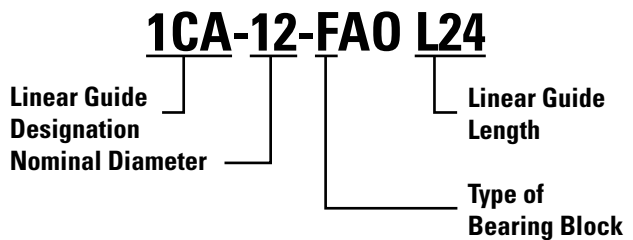

Dimensions (Inch)

Single Continuously Supported Linear Guide with 2 Pillow Blocks

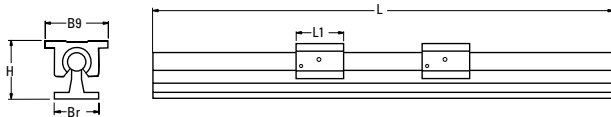

Single Continuously Supported Linear Guide with 1 Twin Pillow Block

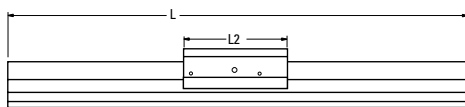

Type SSUPBO Open Type Super Smart and SPB-OPN Open Type Ball Bushing Pillow Blocks

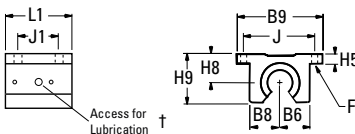

Type SSUTWN Open Type Super Smart and TWN-OPN Open Type Ball Bushing Twin Pillow Blocks

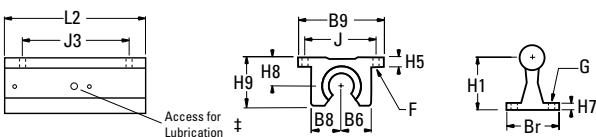

Load Rating and Limit by Direction

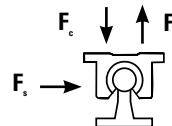

	Dynamic Load Rating	Load Limit
F_c	C	C
F_t	0.5C	0.5C
F_s	C	0.5C

Dynamic Load Rating: Load value used in life calculation.
Load Limit: Maximum allowable load applied to bearing.

Type SRA LinearRace Shaft Support Rail Assembly

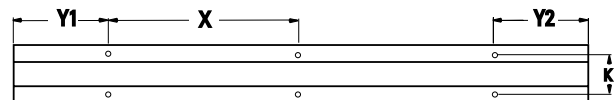

† Size .500 inch has oil lubricant fitting.
Sizes .625 and above have 1/4-28 access for lubrication.

RoundRail Linear Guides

Continuously Supported Linear Guide 1CA Single with 2 Pillow Blocks (Dimensions in inches)

Part Number	Nominal Diameter	L1	H	Br	B9	Pillow Block	Shaft Support Rail Assembly
1CA-08-FAO	.500	1.50	1.812	1.50	2.00	SPB-8-OPN-XS	SRA-8-XS
1CA-12-FAO	.750	1.88	2.437	1.75	2.75	SSUPBO-12-XS	SRA-12-XS
1CA-16-FAO	1.000	2.63	2.937	2.13	3.25	SSUPBO-16-XS	SRA-16-XS
1CA-20-FAO	1.250	3.38	3.625	2.50	4.00	SSUPBO-20-XS	SRA-20-XS
1CA-24-FAO	1.500	3.75	4.250	3.00	4.75	SSUPBO-24-XS	SRA-24-XS

Continuously Supported Linear Guide 1CA Single with 1 Twin Pillow Block (Dimensions in inches)

Part Number	Nominal Diameter	L2	H	Br	B9	Maximum Stroke Length	Pillow Block	Shaft Support Rail Assembly
1CA-08-HAO	.50	3.5	1.812	1.50	2.00	L-(3.5)	TWN-8-OPN-XS	SRA-8-XS
1CA-12-HAO	.75	4.5	2.437	1.75	2.75	L-(4.5)	SSUTWNO-12-XS	SRA-12-XS
1CA-16-HAO	1.00	6.0	2.937	2.13	3.25	L-(6.0)	SSUTWNO-16-XS	SRA-16-XS
1CA-20-HAO	1.25	7.5	3.625	2.50	4.00	L-(7.5)	SSUTWNO-20-XS	SRA-20-XS
1CA-24-HAO	1.50	9.0	4.250	3.00	4.75	L-(9.0)	SSUTWNO-24-XS	SRA-24-XS

Dynamic Load Capacity Matrix (4 million inches travel)

Linear Guide Assembly Part Number	Dynamic Load Capacity (lb.) (Even Distribution)	Pillow Block Part Number	Pillow Block Dynamic Load Capacity (lb.)
1CA-08-FAO	290	SPB-8-OPN-XS	400
1CA-12-FAO	1800	SSUPBO-12-XS	900
1CA-16-FAO	3000	SSUPBO-16-XS	1500
1CA-20-FAO	3730	SSUPBO-20-XS	1865
1CA-24-FAO	6160	SSUPBO-24-XS	3080

Dynamic Load Capacity Matrix (4 million inches travel)

Linear Guide Assembly Part Number	Dynamic Load Capacity (lb.) (Even Distribution)	Pillow Block Part Number	Pillow Block Dynamic Load Capacity (lb.)
1CA-08-HAO	290	TWN-8-OPN-XS	800
1CA-12-HAO	1800	SSUTWNO-12-XS	1800
1CA-16-HAO	3000	SSUTWNO-16-XS	3000
1CA-20-HAO	3730	SSUTWNO-20-XS	3730
1CA-24-HAO	6160	SSUTWNO-24-XS	6160

† Super Ball Bushing Bearings are used in .500 inch size pillow blocks.

Replacement Component Dimensions

Type SPB-OPN and SSUPBO Pillow Blocks (Dimensions in inches)

Part Number	Nom. Dia.	L1	H9	H8	H5	B9	B8	B6	J	J1	F		Wt. (lb)
											Bolt	Hole	
SPB-8-OPN-XS	.500	1.69	1.25	.687	.25	2.00	.75	.69	1.69	1.00	#6	.16	.20
SSUPBO-12-XS	.750	2.06	1.75	.937	.31	2.75	1.00	.94	2.38	1.25	#8	.19	.62
SSUPBO-16-XS	1.000	2.81	2.19	1.187	.38	3.25	1.25	1.19	2.88	1.75	#10	.22	1.24
SSUPBO-20-XS	1.250	3.63	2.81	1.500	.43	4.00	1.63	1.50	3.50	2.00	#10	.22	2.57
SSUPBO-24-XS	1.500	4.00	3.25	1.750	.50	4.75	1.88	1.75	4.12	2.50	1/4	.28	3.94

Top plates are sold separately. Please refer to page 260 under Accessories for P/N and dimensions.

Type TWN-OPN and SSUTWNO

Pillow Blocks (Dimensions in inches)

Part Number	Nom. Dia.	L2	J3	Wt. (lb)
TWN-8-OPN-XS	.500	3.50	2.50	.40
SSUTWNO-12-XS	.750	4.50	3.50	1.24
SSUTWNO-16-XS	1.000	6.00	4.50	2.48
SSUTWNO-20-XS	1.250	7.50	5.50	5.14
SSUTWNO-24-XS	1.500	9.00	6.50	8.08

Housing Material: Aluminum Alloy Black Anodized

Type SRA LinearRace Shaft Support Rail Assembly (Dimensions in inches)

Part Number	Nom. Dia.	H1	H7	Br	K	X	G		Wt. (lb/ft)
							Bolt	Hole	
SRA-8-XS	.500	1.125	.19	1.50	1.00	4	#8	.17	1.26
SRA-12-XS	.750	1.500	.25	1.75	1.25	6	#10	.22	2.50
SRA-16-XS	1.000	1.750	.25	2.13	1.50	6	1/4	.28	4.06
SRA-20-XS	1.250	2.125	.31	2.50	1.88	6	5/16	.34	6.30
SRA-24-XS	1.500	2.500	.38	3.00	2.25	8	5/16	.34	8.60

LinearRace Shaft Support Rail Material: Aluminum Alloy Black Anodized

Support rails are supplied in 24 inch lengths unless quoted otherwise. Maximum length of LinearRace Shaft Support Rail is 72 inches. If longer continuous one-piece LinearRace Shaft Support Rails are required, contact the Thomson Linear Guides Application Engineering department.

Y = distance from end of rail to the center of first mounting hole, Y1 = Y2 unless specified.

RoundRail Linear Guides

Continuous Support 1PA

Fully Supported, Highest Performance, Industry Standard Dimension Metric

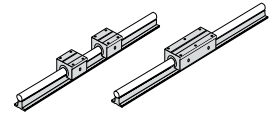

Features

- Requires only one part number to specify the entire linear guide
- Used as a load support, transport, and guidance solution
- Used in continuously supported applications when rigidity is required

Components

- 2 Super Smart Ball Bushing opentype pillow blocks or 1 Super Smart Ball Bushing open twin pillow blocks
- 1 60 Case LinearRace shaft support rail assembly

Dimensions (Inch)

Single Continuously Supported Linear Guide with 2 Pillow Blocks

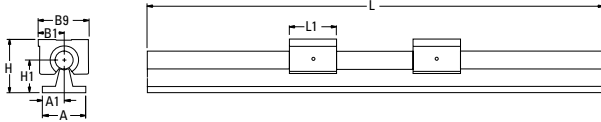

Single Continuously Supported Linear Guide with 1 Twin Pillow Block

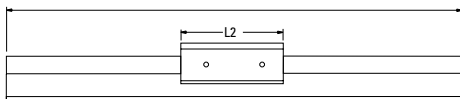

Type SSEPBO Open Type Super Smart Ball Bushing Pillow Blocks

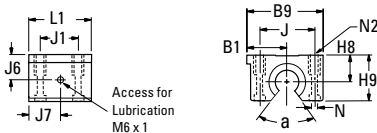

Type SSETWNO Open Type Super Smart Ball Bushing Twin Pillow Blocks

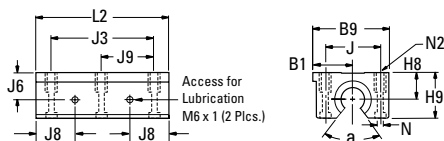

Specifying this Thomson Linear Guide

1. Determine the proper Linear Guide for your load and life requirements.
2. Select the part number.
3. Add the letter "L" followed by the overall length in inches, as a suffix to the part number.

Part Numbering System

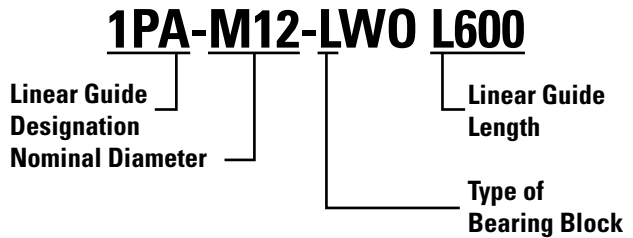

Load Rating and Limit by Direction

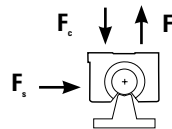

	Dynamic Load Rating	Load Limit
F_c	C	C
F_t	0.5C	0.5C
F_s	C	0.5C

Dynamic Load Rating: Load value used in life calculation.
Load Limit: Maximum allowable load applied to bearing.

Type SRA LinearRace Shaft Support Rail Assembly

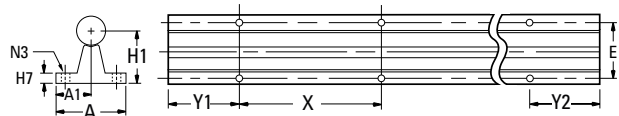

RoundRail Linear Guides

Continuously Supported Linear Guide 1PA Single with 2 Pillow Blocks (Dimensions in inches)

Part Number	Nominal Diameter	L1	H	H1	A	A1	B1	B9	Pillow Block	Shaft Support Rail Assembly
1PA-M12-LWO	12	39	46	28	43	21,5	21,5	43	SPPBO-M12-XS [†]	SRA-M12-XS
1PA-M16-LWO	16	43	52	30	48	24,0	26,5	53	SSEPBO-M16-XS	SRA-M16-XS
1PA-M20-LWO	20	54	63	38	56	28,0	30,0	60	SSEPBO-M20-XS	SRA-M20-XS
1PA-M25-LWO	25	67	72	42	60	30,0	39,0	78	SSEPBO-M25-XS	SRA-M25-XS
1PA-M30-LWO	30	79	88	53	74	37,0	43,5	87	SSEPBO-M30-XS	SRA-M30-XS
1PA-M40-LWO	40	91	105	60	78	39,0	54,0	108	SSEPBO-M40-XS	SRA-M40-XS

Continuously Supported Linear Guide 1PA Single with 1 Twin Pillow Block (Dimensions in inches)

Part Number	Nominal Diameter	L2	H	H1	A	A1	B1	B9	Maximum Stroke Length	Pillow Block	Shaft Support Rail Assembly
1PA-M12-MWO	12	76	46	28	43	21,5	21,5	43	L-(76)	SPTWNO-M12-XS [†]	SRA-M12-XS
1PA-M16-MWO	16	84	52	30	48	24,0	26,5	53	L-(84)	SSETWNO-M16-XS	SRA-M16-XS
1PA-M20-MWO	20	104	63	38	56	28,0	30,0	60	L-(104)	SSETWNO-M20-XS	SRA-M20-XS
1PA-M25-MWO	25	130	72	42	60	30,0	39,0	78	L-(130)	SSETWNO-M25-XS	SRA-M25-XS
1PA-M30-MWO	30	152	88	53	74	37,0	43,5	87	L-(152)	SSETWNO-M30-XS	SRA-M30-XS
1PA-M40-MWO	40	176	105	60	78	39,0	54,0	108	L-(176)	SSETWNO-M40-XS	SRA-M40-XS

Dynamic Load Capacity Matrix (100 km travel)

Linear Guide Assembly Part Number	Dynamic Load Capacity (N) (Even Distribution)	Pillow Block Part Number	Pillow Block Dynamic Load Capacity (N)
1PA-M12-LWO	1500	SPPBO-M12-XS	750
1PA-M16-LWO	4400	SSEPBO-M16-XS	2200
1PA-M20-LWO	8000	SSEPBO-M20-XS	4000
1PA-M25-LWO	13400	SSEPBO-M25-XS	6700
1PA-M30-LWO	16600	SSEPBO-M30-XS	8300
1PA-M40-LWO	27400	SSEPBO-M40-XS	13700

Dynamic Load Capacity Matrix (100 km travel)

Linear Guide Assembly Part Number	Dynamic Load Capacity (N) (Even Distribution)	Pillow Block Part Number	Pillow Block Dynamic Load Capacity (N)
1PA-M12-MWO	1220	SPTWNO-M12-XS	1500
1PA-M16-MWO	4400	SSETWNO-M16-XS	4400
1PA-M20-MWO	8000	SSETWNO-M20-XS	8000
1PA-M25-MWO	13400	SSETWNO-M25-XS	13400
1PA-M30-MWO	16600	SSETWNO-M30-XS	16600
1PA-M40-MWO	27400	SSETWNO-M40-XS	27400

† Super Plus Ball Bushing Bearings are used in 12 mm size pillow blocks.

Replacement Component Dimensions

Type SSEPBO Pillow Blocks (Dimensions in inches)

Part Number	Nom. Dia.	L1	H8	H9	B1	B9	J6	J7	J	J1	N Dia.	N2	a Deg.	Mass (kg)
SPPBO-M12-XS	12	39	18	28	215	43	16,7	19,5	32	23	43	M5	66	0,11
SSEPBO-M16-XS	16	43	22	35	265	53	22,0	21,5	40	26	53	M6	66	0,17
SSEPBO-M20-XS	20	54	25	41	300	60	25,0	27,0	45	32	66	M8	60	0,30
SSEPBO-M25-XS	25	67	30	50	390	78	31,5	33,5	46	40	84	M10	60	0,57
SSEPBO-M30-XS	30	79	35	60	435	87	33,0	39,5	68	45	84	M10	60	0,87
SSEPBO-M40-XS	40	91	45	77	540	108	43,5	45,5	86	58	105	M12	60	1,62

Housing Material: Aluminum Alloy Grey Anodized.

Top plates are sold separately. Please refer to page 260 under Accessories for P/N and dimensions.

Type SSETWNO Pillow Blocks (Dim. in in.)

Part Number	Nom. Dia.	L2	J3	J8	J9	Mass (kg)
SPTWNO-M12-XS	12	76	56	19,5	28	0,22
SSETWNO-M16-XS	16	84	64	21,5	32	0,34
SSETWNO-M20-XS	20	104	76	27,0	38	0,63
SSETWNO-M25-XS	25	130	94	33,6	47	1,18
SSETWNO-M30-XS	30	152	106	39,5	53	1,70
SSETWNO-M40-XS	40	176	124	45,5	62	3,18

Housing Material: Aluminum Alloy Grey Anodized

Type SRA LinearRace Shaft Support Rail Assembly (Dimensions in inches)

Part Number	Nom. Dia.	H1	H7	A	A1	E	X	N3 Dia.	Mass (kg/m)
SRA-M12-XS	12	28	5	43	21,5	29	75	4,5	4,1
SRA-M16-XS	16	30	5	48	24,0	33	100	5,5	6,2
SRA-M20-XS	20	38	6	56	28,0	37	100	6,6	9,5
SRA-M25-XS	25	42	6	60	30,0	42	120	6,6	13,7
SRA-M30-XS	30	53	8	74	37,0	51	150	8,6	20,0
SRA-M40-XS	40	60	8	78	39,0	55	200	8,6	32,5

LinearRace Shaft Support Rail Material: Aluminum Alloy Grey Anodized

Support rails are supplied in 600mm lengths unless quoted otherwise. Maximum length of LinearRace Shaft Support Rail is 600mm. If longer continuous one-piece LinearRace Shaft Support Rails are required, contact the Thomson Linear Guides Application Engineering department.

Y = distance from end of rail to the center of first mounting hole, Y1 = Y2 unless specified.

RoundRail Linear Guides

FluoroNyliner Linear Guides

**Corrosion resistant, smooth, quiet,
industry standard envelope**

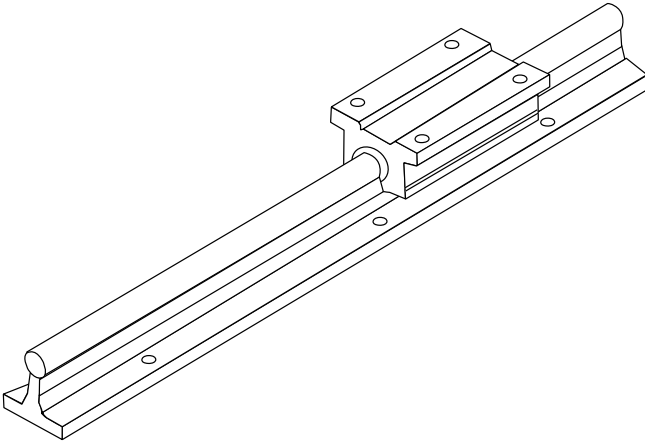

FluoroNyliner Linear Guides Offer:

- Thomson's new FluoroNyliner Bushing Bearings that are made from the most advanced polymer components to achieve maximum performance levels
- Contamination resistance. The FluoroNyliner Linear Guides are practically immune to adverse environments, such as water wash-down conditions and magnetic interference
- Self-Aligning Pillow Blocks for ease of use
- Increased bearing load capacities (or 'PV' ratings) and obtainable travel life, when used with Thomson stainless steel, 60 Case Linear Race shaft, when compared to competitive assemblies.
- Specification conformance with FDA and non-lubricated applications
- Use in linear and rotary motion applications
- Operates in temperatures from -400°F to 550°F / -240°C to 287°C

RoundRail Linear Guides

FluoroNyliner 1VA

Corrosive/Contaminated Environments Inch

Features

- Requires only one part number to specify the entire linear guide
- Used as a load support, transport, and guidance solution
- Used in continuously supported applications when rigidity is required

Components

- 2 self-aligning FluoroNyliner Bushing bearing open pillow blocks or
- 1 self-aligning FluoroNyliner Bushing bearing open twin pillow block
- 1 stainless steel 60 Case LinearRace shaft support rail assembly

Dimensions (Inch)

Single Continuously Supported Linear Guide with 2 Pillow Blocks

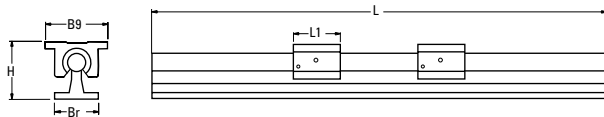

Single Continuously Supported System with 1 Twin Pillow Block

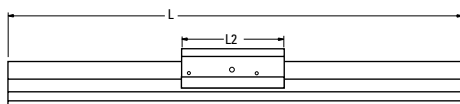

FluoroNyliner Linear Guide Pillow Block Dimensions

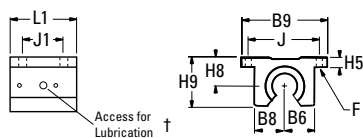

FluoroNyliner Linear Guide Twin Pillow Block Dimensions

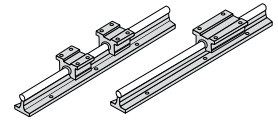
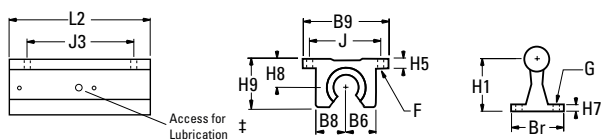

Specifying this Thomson Linear Guide

1. Determine the proper Linear Guide for your load and life requirements.
2. Select the part number.
3. Add the letter "L" followed by the overall length in inches, as a suffix to the part number.

Part Numbering System

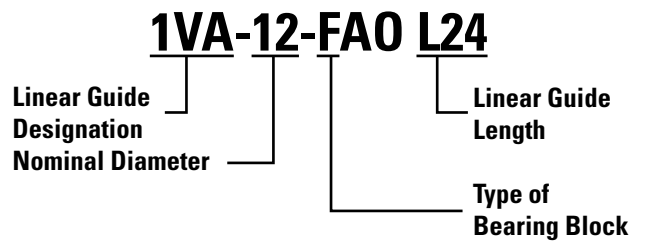

Load Rating and Limit by Direction

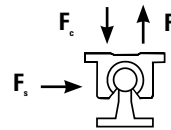

	Dynamic Load Rating	Load Limit
F_c	C	C
F_t	0.5C	0.5C
F_s	C	0.5C

Dynamic Load Rating: PV value used in life calculation.
Load Limit: Maximum allowable PV applied to bearing.

Type SRA LinearRace Shaft Support Rail Assembly

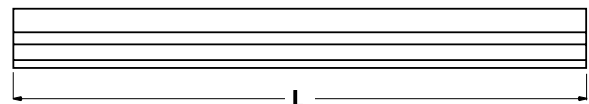
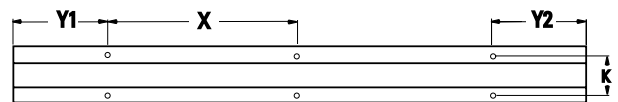

RoundRail Linear Guides

FluoroNyliner Linear Guide 1VA Single Continuously Supported with 2 Pillow Blocks (Dimensions in inches)

Part Number	Nominal Diameter	L1	H	Br	B9	Pillow Block	Shaft Support Rail Assembly
1VA-08-FAO	.500	1.50	1.812	1.50	2.00	FNYBUPB008A-XS	SRA-8-XS-SS
1VA-12-FAO	.750	1.88	2.437	1.75	2.75	FNYBUPB012A-XS	SRA-12-XS-SS
1VA-16-FAO	1.000	2.63	2.937	2.13	3.25	FNYBUPB016A-XS	SRA-16-XS-SS
1VA-20-FAO	1.250	3.38	3.625	2.50	4.00	FNYBUPB020A-XS	SRA-20-XS-SS
1VA-24-FAO	1.500	3.75	4.250	3.00	4.75	FNYBUPB024A-XS	SRA-24-XS-SS

FluoroNyliner Linear Guide 1VA Single Continuously Supported with 1 Twin Pillow Block (Dimensions in inches)

Part Number	Nominal Diameter	L2	H	Br	B9	Maximum Stroke Length	Pillow Block	Shaft Support Rail Assembly
1VA-08-HAO	.50	3.5	1.812	1.50	2.00	L-(3.5)	FNYBUTWNO08A-XS	SRA-8-XS-SS
1VA-12-HAO	.75	4.5	2.437	1.75	2.75	L-(4.5)	FNYBUTWNO12A-XS	SRA-12-XS-SS
1VA-16-HAO	1.00	6.0	2.937	2.13	3.25	L-(6.0)	FNYBUTWNO16A-XS	SRA-16-XS-SS
1VA-20-HAO	1.25	7.5	3.625	2.50	4.00	L-(7.5)	FNYBUTWNO20A-XS	SRA-20-XS-SS
1VA-24-HAO	1.50	9.0	4.250	3.00	4.75	L-(9.0)	FNYBUTWNO24A-XS	SRA-24-XS-SS

Maximum Operating Parameters per Bearing

Characteristic	Limit
Linear Temperature Range	-240° C to 288° C (-400° F to 550° F)
Velocity, dry	42.7 m/min. Continuous
Velocity, dry	122 m/min. Intermittent
Velocity, lubricated	122 m/min. Continuous
Pressure	10.35 MPa
PV	21 MPa/m/min

Replacement Component Dimensions

Self-Aligning Pillow Blocks (Dimensions in inches)

Part Number	Nom. Dia.	L1	H9	H8	H5	B9	B8	B7	J	J1	F		Wt. (lb)	Part Number	Nom. Dia.	L2	J3	Wt. (lb)
											Bolt	Hole						
FNYBUPB008A-XS	.500	1.69	1.25	.687	.25	2.00	.75	.69	1.69	1.00	#6	.16	.20	FNYBUTWNO08A-XS	.500	3.50	2.50	.40
FNYBUPB012A-XS	.750	2.06	1.75	.937	.31	2.75	1.00	.94	2.38	1.25	#8	.19	.51	FNYBUTWNO12A-XS	.750	4.50	3.50	1.02
FNYBUPB016A-XS	1.000	2.81	2.19	1.187	.38	3.25	1.25	1.19	2.88	1.75	#10	.22	1.03	FNYBUTWNO16A-XS	1.000	6.00	4.50	2.06
FNYBUPB020A-XS	1.250	3.63	2.81	1.500	.43	4.00	1.63	1.50	3.50	2.00	#10	.22	2.15	FNYBUTWNO20A-XS	1.250	7.50	5.50	4.30
FNYBUPB024A-XS	1.500	4.00	3.25	1.750	.50	4.75	1.88	1.75	4.12	2.50	1/4	.28	3.29	FNYBUTWNO24A-XS	1.500	9.00	6.50	6.88

Housing Material: Aluminum Alloy Black Anodized

Housing Material: Aluminum Alloy Black Anodized

Performance Note: For detailed explanations of FluoroNyliner Linear Guide Dynamic and Static Load Capacities, Frictional Characteristics, Wear Rates, Speeds, and Life Expectancy please contact the Thomson Linear Guides Applications Engineering department.

Product Note: FluoroNyliner linear guides are shipped free of all lubricants. It is the responsibility of the product user to determine lubricant compatibility with the FluoroNyliner bearing material.

Product Options: FluoroNyliner linear guides are available with various inner race materials and platings to accommodate different environments.

Top plates are sold separately. Please refer to page 260 under accessories for P/N and dimensions.

Type SRA LinearRace Shaft Support Rail Assembly (Dimensions in inches)

Part Number	Nom. Dia.	H1	H7	Br	K	X	G		Wt. (lb/ft)
							Bolt	Hole	
SRA-8-XS	.500	1.125	.19	1.50	1.00	4	#8	.17	1.26
SRA-12-XS	.750	1.500	.25	1.75	1.25	6	#10	.22	2.50
SRA-16-XS	1.000	1.750	.25	2.13	1.50	6	1/4	.28	4.06
SRA-20-XS	1.250	2.125	.31	2.50	1.88	6	5/16	.34	6.30
SRA-24-XS	1.500	2.500	.38	3.00	2.25	8	5/16	.34	8.60

LinearRace Shaft Support Rail Material: Aluminum Alloy Black Anodized

Support rails are supplied in 24 inch lengths unless quoted otherwise. Maximum length of LinearRace Shaft Support Rail is 72 inches. If longer continuous one-piece LinearRace Shaft Support Rails are required, contact the Thomson Linear Guide Application Engineering department.

Y = distance from end of rail to the center of first mounting hole, Y1 = Y2 unless specified.

RoundRail Linear Guides

Side Mounted Linear Ball Guides

**Low profile, high loads in all directions,
easy to install**

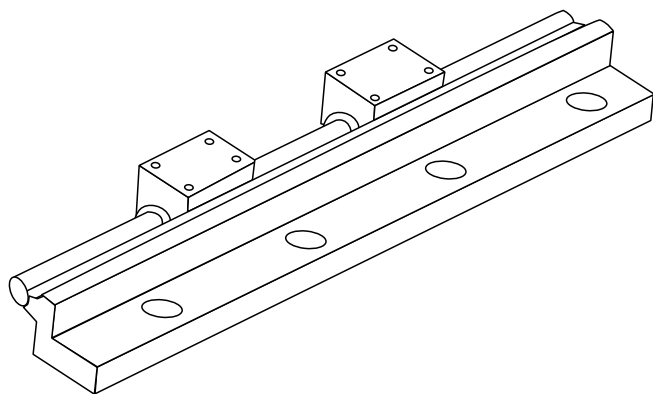

Side Mounted Linear Ball Guides Offer:

- Increased life within the same envelope. RoundRail linear guides feature the new patented Super Smart Ball Bushing Bearings for up to 216X the life or 6X the load capacity of conventional bearings.
- Cost savings: save time and money preparing your mounting surfaces before bolting down RoundRail linear guides
- Slide mounted geometry for increased mounting flexibility
- Superior performance. Continuously supported for maximum (down- & side-) load applications without concerns for shaft deflection
- The RoundRail Advantage. The inherent self-aligning-in-all-directions design of the Super Smart Ball Bushing bearing allows for ultra smooth travel when mounted to wider toleranced prepared surfaces
- Unlimited travel lengths without concerns for machined reference edges or butt joint alignment
- The Super Smart Ball Bushing bearing... the most technologically advanced and most robust linear bearing in the world
- Corrosion resistant versions for maximum performance in harsh environments.

RoundRail Linear Guides

Side Mounted 1DA

Side Mounted for Low Profile Inch

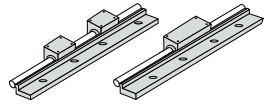

Features

- Continuously supported design increases rigidity and provides for unlimited linear guide travel lengths
- Versatile Side Support Rail Assembly geometry for optimizing mounting ability
- Side mounted design provides an increase in pull-off load capacity

Components

- 2 Super Smart Ball Bushing modified open type pillow blocks or 1 Super Smart Ball Bushing modified open type twin pillow block.
- 1 60 Case LinearRace shaft side mounted support rail assembly

Specifying this Thomson Linear Guide

1. Determine the proper Linear Guide for your load and life requirements.
2. Select the part number.
3. Add the letter "L" followed by the overall length in inches, as a suffix to the part number.

Part Numbering System

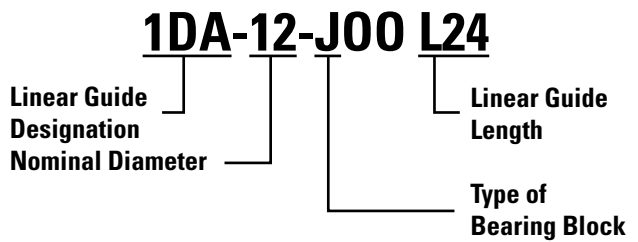

Dimensions (Inch)

Single Side Mounted Linear Guide with 2 Pillow Blocks

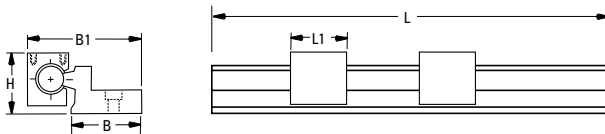

Single Side Mounted Linear Guide with 1 Twin Pillow Block

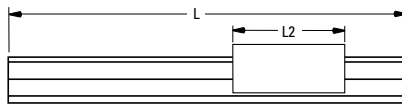

Type SSUPB0-MOD and SPB-OPN-MOD Open Type Pillow Blocks

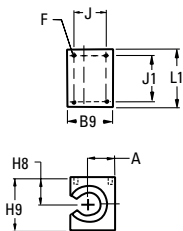

Type SSUTWNO-MOD and TWN-OPN-MOD Pillow Blocks

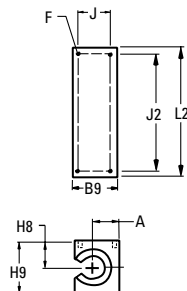

Load Rating and Limit by Direction

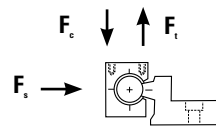

	Dynamic Load Rating	Load Limit
F_c	C	C
F_t	0.5C	0.5C
F_s	C	0.5C

Dynamic Load Rating: Load value used in life calculation.
Load Limit: Maximum allowable load applied to bearing.

Type SSRA Side Mounted LinearRace Shaft Support Rail Assembly

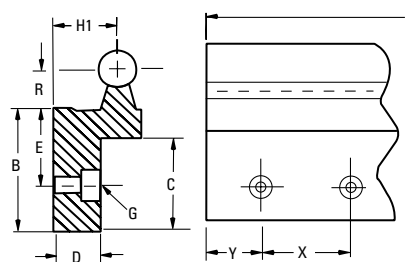

RoundRail Linear Guides

Side Mounted Linear Guide 1DA Single Side Mounted with 2 Pillow Blocks (Dimensions in inches)

Part Number	Nominal Diameter	H	B	B1	L1	Pillow Block	Shaft Support Rail Assembly
1DA-08-J00	.500	1.562	1.44	2.61	1.50	SPB-8-OPN-MOD	SSRA-8
1DA-12-J00	.750	2.062	1.94	3.55	1.88	SSUPBO-12-MOD	SSRA-12
1DA-16-J00	1.000	2.562	2.44	4.49	2.63	SSUPBO-16-MOD	SSRA-16

Side Mounted Linear Guide 1DA Single Side Mounted with 1 Twin Pillow Block (Dimensions in inches)

Part Number	Nominal Diameter	H	B	B1	L2	Maximum Stroke Length	Pillow Block	Shaft Support Rail Assembly
1DA-08-K00	.50	1.562	1.44	2.61	3.5	L-(3.5)	TWN-8-OPN-MOD	SSRA-8
1DA-12-K00	.75	2.062	1.94	3.55	4.5	L-(4.5)	SSUTWNO-12-MOD	SSRA-12
1DA-16-K00	1.00	2.562	2.44	4.49	6.0	L-(6.0)	SSUTWNO-16-MOD	SSRA-16

Mounting Configurations

The following mounting configurations depict ideas for combining the Side Mounted Continuously Supported Linear Guides into your linear motion application. If you need further information, contact the Thomson Application Engineering Department.

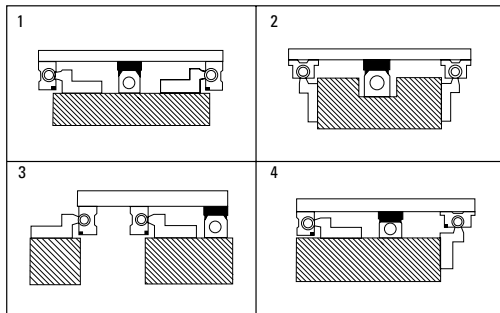

Pillow blocks shown are the standard SSUPBO or SPB-OPN style. To order System 1DA with standard pillow blocks, order the Side Mounted Shaft Rail Assembly (SSRA) and the SSUPBO or SPB-OPN separately.

Dynamic Load Capacity Matrix (4 million inches travel)

Linear Guide Assembly Part Number	Dynamic Load Capacity (N) (Even Distribution)	Pillow Block Part Number	Pillow Block Dynamic Load Capacity (N)
1DA-08-J00	240	SPB-8-OPN-MOD	120
1DA-12-J00	1600	SSUPBO-12-MOD	800
1DA-16-J00	2700	SSUPBO-16-MOD	1350
1DA-08-K00	240	TWN-8-OPN-MOD	240
1DA-12-K00	1600	SSUTWNO-12-MOD	1600
1DA-16-K00	2700	SSUTWNO-16-MOD	2700

† Super Ball Bushing Bearings are used in .500 inch size pillow blocks.

Replacement Component Dimensions

Type SPB-OPN-MOD and SSUPBO-MOD Pillow Block (Dimensions in inches)

Part Number	Nom. Dia.	H8	H9	A	B9	L1	J	J1	F	Wt. (lb)
SPB-8-OPN-MOD	.500	.687	1.44	.67	1.12	1.50	.812	1.250	#8-32	.18
SSUPBO-12-MOD	.750	.937	1.94	.92	1.56	1.88	1.187	1.562	#10-32	.45
SSUPBO-16-MOD	1.000	1.187	2.44	1.17	2.00	2.63	1.438	2.250	1/4-20	.98

Housing Material: Aluminum Alloy Black Anodized

Top plates are sold separately. Please refer to page 260 under accessories for P/N and dimensions.

Type TWN-OPN-MOD and SSUTWNO-MOD Pillow Blocks (Dimensions in inches)

Part Number	Nom. Dia.	L2	J2	Wt. (lb)
TWN-8-OPN-MOD	.500	3.5	3.00	.39
SSUTWNO-12-MOD	.750	4.5	4.00	1.00
SSUTWNO-16-MOD	1.000	6.0	5.25	2.11

Housing Material: Aluminum Alloy Black Anodized

Type SSRA LinearRace Shaft Support Rail Assembly (Dimensions in inches)

Part Number	Nom. Dia.	H1	B	R	E	D	C	X	G		Wt. (lb/ft)
									Bolt	Hole	
SSRA-8-XS	.500	.875	1.44	.500	1.00	.49	1.06	4	1/4	.28	2.05
SSRA-12-XS	.750	1.125	1.94	.688	1.31	.75	1.44	6	5/16	.34	4.00
SSRA-16-XS	1.000	1.375	2.44	.875	1.63	.88	1.81	6	3/8	.41	6.25

(1) For standard lengths LinearRace Shaft Support Rail Material: Aluminum Black Anodized

Support rails are supplied in 24 inch lengths unless quoted otherwise. Maximum length of LinearRace Shaft Support Rail is 72 inches. If longer continuous one-piece LinearRace Shaft Support Rails are required, contact the Thomson Linear Guides Application Engineering department.

Y = distance from end of rail to the center of first mounting hole, Y1 = Y2 unless specified.

RoundRail Linear Guides

Dual Shaft

Low profile, high loads in all directions, easy to install

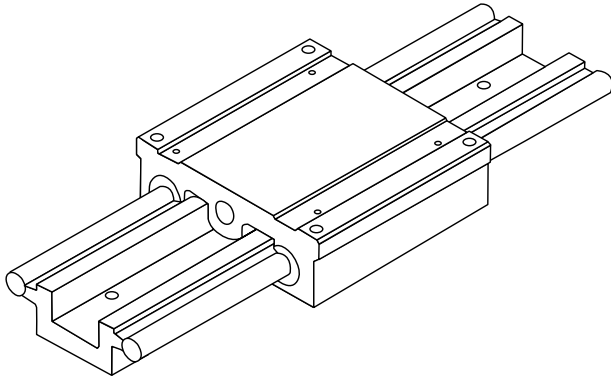

Dual Shafts Offer:

- This performance proven Linear guide has an extremely low profile and features external rails with maximum bearing spacing. This provides the user with high pitch, yaw and roll moment capability. The load capacity is the same when mounted in the inverted position
- Corrosion resistant options are also available for demanding environmental conditions. These include chrome plated or stainless steel shafting and corrosion resistant bearings
- The inherent self aligning design of the Super Smart Ball Bushing bearings allow for more deviation in the flatness of the mounting surface. This can dramatically reduce the installed cost of the Linear Guide
- The base extrusion has a reference edge for registration in your machine. Unlimited travel lengths can be realized by combining base and shaft segments. The shafts and bases are staggered to allow keying of the subsequent stage.

RoundRail Linear Guides

Dual Shaft Rail 2DA with Integrated Carriage Unpack and Install Inch

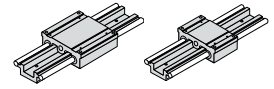

Features

- Used in continuously supported applications when rigidity is required
- Adaptable to any drive system
- Pre-aligned and preassembled for immediate installation and use
- Designed for medium to heavy loads

Components

- 1 Dual LinearRace shaft rail assembly
- 1 integrated carriage with 4 open type Super Smart Ball Bushing Bearings

Specifying this Thomson Linear Guide

1. Determine the proper Linear Guide for your load and life requirements.
2. Select the part number.
3. Add the letter "L" followed by the overall length in inches, as a suffix to the part number.

Part Numbering System

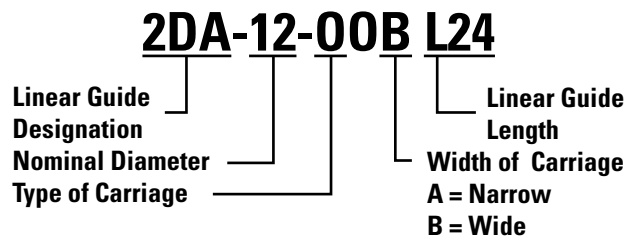

Dimensions (Inch)

2DA XX 00B
Rail Cross Section

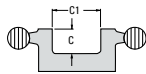

Dual Shaft Rail Linear Guide with Integrated Full Length Carriage

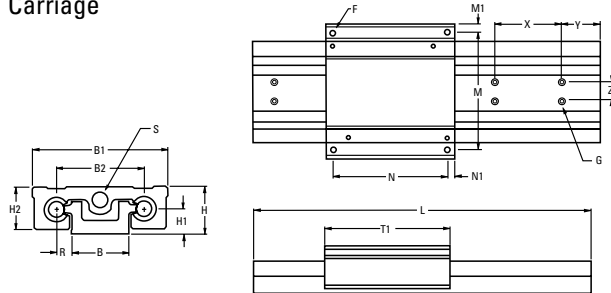

Load Rating and Limit by Direction

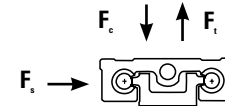

	Dynamic Load Rating	Load Limit
F_c	C	0.5C
F_t	C	0.5C
F_s	0.5C	0.5C

Dynamic Load Rating: load value used in life calculation.
Load Limit: Maximum allowable load applied to bearing.

2DA XX 00A
Rail Cross Section

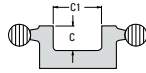

Dual Shaft Rail Linear Guide with Integrated Short Length Carriage

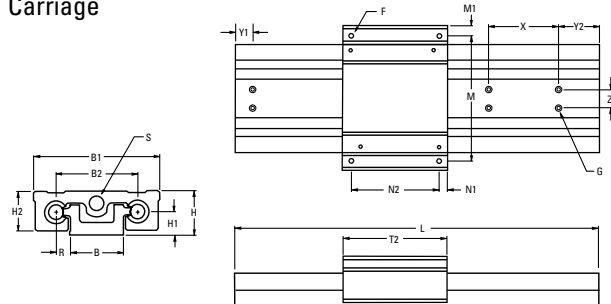

Load Rating and Limit by Direction

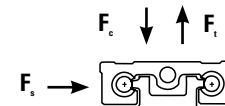

	Dynamic Load Rating	Load Limit
F_c	C	0.5C
F_t	C	0.5C
F_s	0.5C	0.5C

Dynamic Load Rating: load value used in life calculation.
Load Limit: Maximum allowable load applied to bearing.

RoundRail Linear Guides

Dual Shaft Rail Linear Guide 2DA with Integrated Carriage (Dimensions in inches)

Part Number	Nominal Diameter	T1	H	H1	H2	B	R	B1	B2	C	C1
2DA-08-00B	.500	4.5	1.625	.875	1.43	2.00	.500	4.6	3.0	.64	1.25
2DA-12-00B	.750	6.0	2.125	1.125	1.93	2.63	.688	6.1	4.0	.75	1.662
2DA-16-00B	1.000	7.5	2.625	1.375	2.44	3.25	.875	7.6	5.0	.99	2.00

Dual Shaft Rail Linear Guide 2DA with Integrated Carriage (Dimensions in inches)

Part Number	N	N1	M	M1	X	Z	S As Extruded	F	G		Maximum Stroke Length	Carriage	Dual Shaft Rail Assembly
									Bolt	Hole			
2DA-08-00B	4.00	.25	4.00	.30	4.0	.75	.50	#10-32	1/4	.28	L-(4.5)	DSRC-08-SB	DSRA-08
2DA-12-00B	5.25	.37	5.25	.42	6.0	1.0	.70	1/4-20	5/16	.34	L-(6.0)	DSRC-12-SB	DSRA-12
2DA-16-00B	6.75	.37	6.75	.42	6.0	1.25	.90	5/16-18	3/8	.41	L-(7.5)	DSRC-16-SB	DSRA-16

Support rails are supplied in 24 inch lengths unless quoted otherwise.

Dual Shaft Rail Support Material: Black Anodized Aluminum Alloy

Maximum continuous length of support rails is 72". If longer continuous shaft support rails are required, please contact the Thomson Linear Guides Application Engineering department.

Y = distance from end of rail to the center of first mounting hole, Y1 = Y2 unless specified.

Dynamic Load Capacity Matrix (4 million inches travel)

Linear Guide Assembly Part Number	Dynamic Load Capacity (lb) (Even Distribution)	Dynamic Roll Moment (in-lb)
2DA-08-00B	480	720
2DA-12-00B	3200	6400
2DA-16-00B	5400	13500

Note: Above load ratings used for life calculations. Load limit of assembly 50%.

Dual Shaft Rail Linear Guide 2DA with Integrated Carriage (Dimensions in inches)

Part Number	Nominal Diameter	T2	H	H1	H2	B	R	B1	B2	C	C1
2DA-08-00A	.500	3.5	1.625	.875	1.43	2.00	.500	4.6	3.0	.64	1.25
2DA-12-00A	.750	4.5	2.125	1.125	1.93	2.63	.688	6.1	4.0	.75	1.662
2DA-16-00A	1.000	6.0	2.625	1.375	2.44	3.25	.875	7.6	5.0	.99	2.00

Dual Shaft Rail Linear Guide 2DA with Integrated Carriage (Dimensions in inches)

Part Number	N	N2	M	M1	X	Z	S As Extruded	F	G		Maximum Stroke Length	Carriage	Dual Shaft Rail Assembly
									Bolt	Hole			
2DA-08-00A	.25	3.00	4.00	.30	4.0	.75	.50	#10-32	1/4	.28	L-(3.5)	DSRC-08-SA	DSRA-08
2DA-12-00A	.37	3.75	5.25	.42	6.0	1.0	.70	1/4-20	5/16	.34	L-(4.5)	DSRC-12-SA	DSRA-12
2DA-16-00A	.37	5.25	6.75	.42	6.0	1.25	.90	5/16-18	3/8	.41	L-(6.0)	DSRC-16-SA	DSRA-16

Support rails are supplied in 24 inch lengths unless quoted otherwise.

Dual Shaft Rail Support Material: Black Anodized Aluminum Alloy

Maximum continuous length of support rails is 72". If longer continuous shaft support rails are required, please contact the Thomson Linear Guides Application Engineering department.

Y = distance from end of rail to the center of first mounting hole, Y1 = Y2 unless specified.

† Super Ball Bushing Bearings are used in 500 inch size carriages.

Dynamic Load Capacity Matrix (4 million inches travel)

Linear Guide Assembly Part Number	Dynamic Load Capacity (lb) (Even Distribution)	Dynamic Roll Moment (in-lb)
2DA-08-00A	480	720
2DA-12-00A	3200	6400
2DA-16-00A	5400	13500

Note: Above load ratings used for life calculations. Load limit of assembly 50%.

RoundRail Linear Guides

Twin Shaft Web

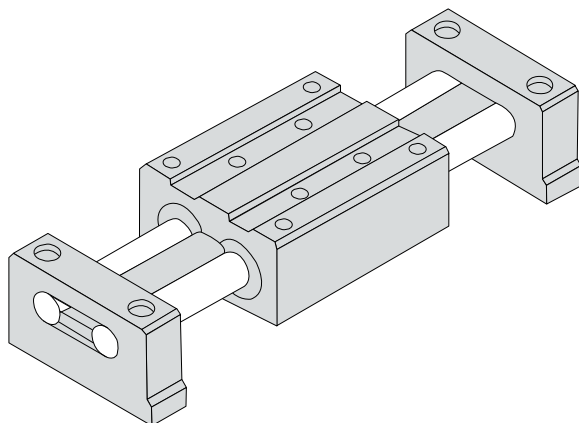

**High roll moment torque resistance,
high rigidity, smooth, easy to install**

Twin Shaft Web Linear Ball Guides Offer:

- Twin Shaft Web design for high roll moment capacity, high rigidity and ultra smooth travel
- Pre-aligned shafts, end supported for gantry style or 'bridge' applications
- Available in horizontal and vertical orientations for increased mounting flexibility
- End supported for quicker and easy installation
- The Super Smart Ball Bushing bearing... the most technologically advanced and most robust linear bearing in the world
- The RoundRail Advantage. The inherent self-aligning-in-all-directions design of the Super Smart Ball Bushing bearing allows for ultra smooth travel when mounted to wider toleranced prepared surfaces
- Cost savings: save time and money preparing your mounting surfaces before bolting down RoundRail linear guides
- Corrosion resistant versions for maximum performance in harsh environments.

RoundRail Linear Guides

Twin Shaft Web 2CA with Universal Carriage Unpack and Install Inch

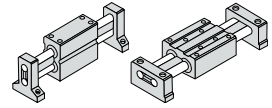

Features

- Used when spanning or bridging a gap
- Double LinearRace shaft and welded integral web design maximizes torque and dramatically improves deflection characteristics
- Pre-aligned for quick and easy installation
- Designed to move medium loads with virtually frictionless travel

Components

- Universal integrated, carriage with 4 open type Super Smart Ball Bushing Bearings
- Twin welded 60 Case LinearRace shafts with integral web
- 2 vertical or horizontal double end supports

Specifying this Thomson Linear Guide

1. Determine the proper Linear Guide for your load and life requirements.
2. Select the part number.
3. Add the letter "L" followed by the overall length in inches, as a suffix to the part number.

Part Numbering System

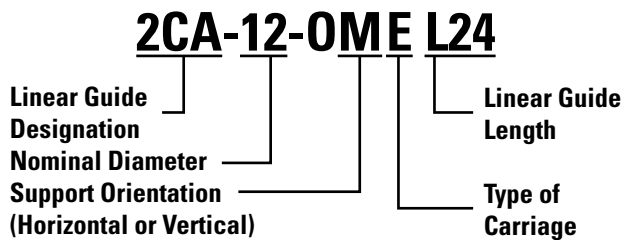

Dimensions (Inch)

Twin Shaft Web Linear Guide with Universal Carriage
(Vertical Configuration)

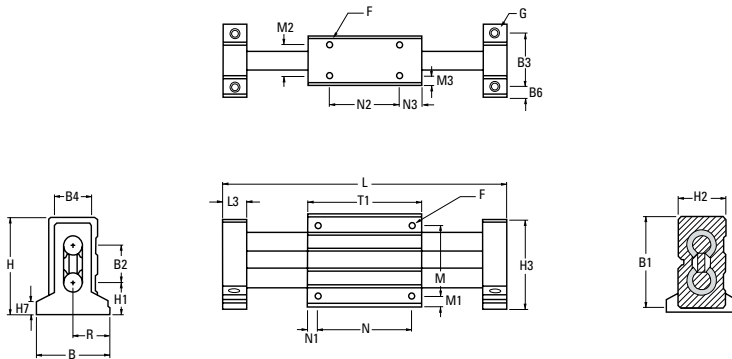

Twin Shaft Web Linear Guide with Universal Carriage
(Horizontal Configuration)

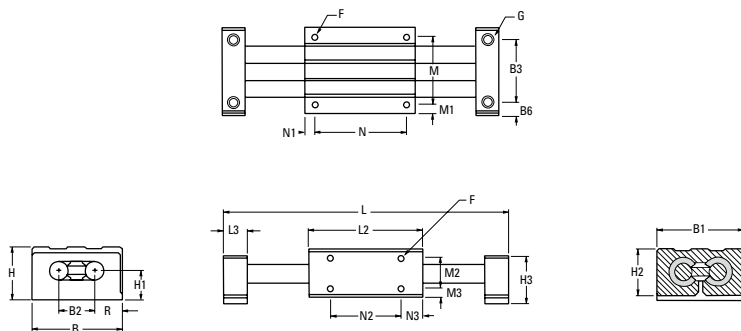

RoundRail Linear Guides

Twin Shaft Web Linear Guide End Supported 2CA (Vertical Configuration) (Dimensions in inches)

Part Number	Nominal Diameter	L3	H	H1	H3	H7	B	R	B2	B3	B4	B6	T1	N
2CA-08-OKE	.500	.63	2.750	.875	2.56	.38	2.25	1.125	1.13	1.63	1.12	.31	3.5	3.00
2CA-12-OKE	.750	.75	3.625	1.125	3.44	.56	3.00	1.500	1.50	2.25	1.63	.38	4.5	4.00
2CA-16-OKE	1.000	1.00	4.625	1.375	4.50	.75	4.00	2.00	2.00	3.00	2.25	.50	6.0	5.25

Twin Shaft Web Linear Guide End Supported 2CA (Vertical Configuration) (Dimensions in inches)

Part Number	N1	N2	N3	H2	B1	M	M1	M2	M3	F	G		Maximum Stroke Length	Dual Shaft Rail Assembly
											Bolt	Hole		
2CA-08-OKE	.25	2.5	.50	1.5	2.62	2.00	.31	.88	.31	#10-32	#10	.22	L-(4.75)	TSW-08
2CA-12-OKE	.25	3.5	.50	2.0	3.50	2.87	.31	1.38	.31	1/4-20	1/4	.28	L-(6.00)	TSW-12
2CA-16-OKE	.38	4.5	.75	2.5	4.50	3.62	.44	1.62	.44	5/16-18	5/16	.34	L-(8.00)	TSW-16

Maximum Length is 72 inches.

2CA (Vertical Config.) Carriage and End Support Part No.

Linear Guide Part Number	Carriage Part Number	End Support Part Number
2CA-08-OKE	WC-08	WSB-08-V
2CA-12-OKE	WC-12	WSB-12-V
2CA-16-OKE	WC-16	WSB-16-V

Dynamic Load Capacity Matrix (4 million inches travel)

Linear Guide Assembly Part Number	Dynamic Load Capacity (lb.) (Even Distribution)	Pillow Block Dynamic Load Capacity (lb.)
2CA-08-OKE	290	165
2CA-12-OKE	1800	1350
2CA-16-OKE	3000	3000

Shaft Deflection Note:

Load limit may be below the dynamic load rating due to shaft deflection.

Bearings can accommodate up to 1/2° deflection.

See Engineering section (page 275) for Deflection calculations.

† Super Ball Bushing Bearings are used in .500 inch size carriages.

Twin Shaft Web Linear Guide End Supported 2CA (Horizontal Configuration) (Dimensions in inches)

Part Number	Nominal Diameter	L3	H	H1	H3	H7	B	R	B2	B3	B4	B6	T1	N
2CA-08-OME	.500	.63	2.750	.875	1.60	.38	2.25	1.125	1.13	1.63	1.12	.31	3.5	3.00
2CA-12-OME	.750	.75	3.625	1.125	2.00	.56	3.00	1.500	1.50	2.25	1.63	.38	4.5	4.00
2CA-16-OME	1.000	1.00	4.625	1.375	2.50	.75	4.00	2.00	2.00	3.00	2.25	.50	6.0	5.25

Twin Shaft Web Linear Guide End Supported 2CA (Horizontal Configuration) (Dimensions in inches)

Part Number	N1	N2	N3	H2	B1	M	M1	M2	M3	F	G		Maximum Stroke Length	Dual Shaft Rail Assembly
											Bolt	Hole		
2CA-08-OME	.25	2.5	.50	1.5	2.62	2.00	.31	.88	.31	#10-32	#10	.22	L-(4.75)	TSW-08
2CA-12-OME	.25	3.5	.50	2.0	3.50	2.87	.31	1.38	.31	1/4-20	1/4	.28	L-(6.00)	TSW-12
2CA-16-OME	.38	4.5	.75	2.5	4.50	3.62	.44	1.62	.44	5/16-18	5/16	.34	L-(8.00)	TSW-16

Maximum Length is 72 inches.

2CA (Horizontal Config.) Carriage and End Support Part No.

Linear Guide Part Number	Carriage Part Number	End Support Part Number
2CA-08-OME	WC-08	WSB-08-H
2CA-12-OME	WC-12	WSB-12-H
2CA-16-OME	WC-16	WSB-16-H

Dynamic Load Capacity Matrix (4 million inches travel)

Linear Guide Assembly Part Number	Dynamic Load Capacity (lb.) (Even Distribution)	Pillow Block Dynamic Load Capacity (lb.)
2CA-08-OME	290	165
2CA-12-OME	1800	1350
2CA-16-OME	3000	3000

Shaft Deflection Note:

Load limit may be below the dynamic load rating due to shaft deflection.

Bearings can accommodate up to 1/2° deflection.

See Engineering section (page 275) for Deflection calculations.

† Super Ball Bushing Bearings are used in .500 inch size carriages.

Accessories

Accessories

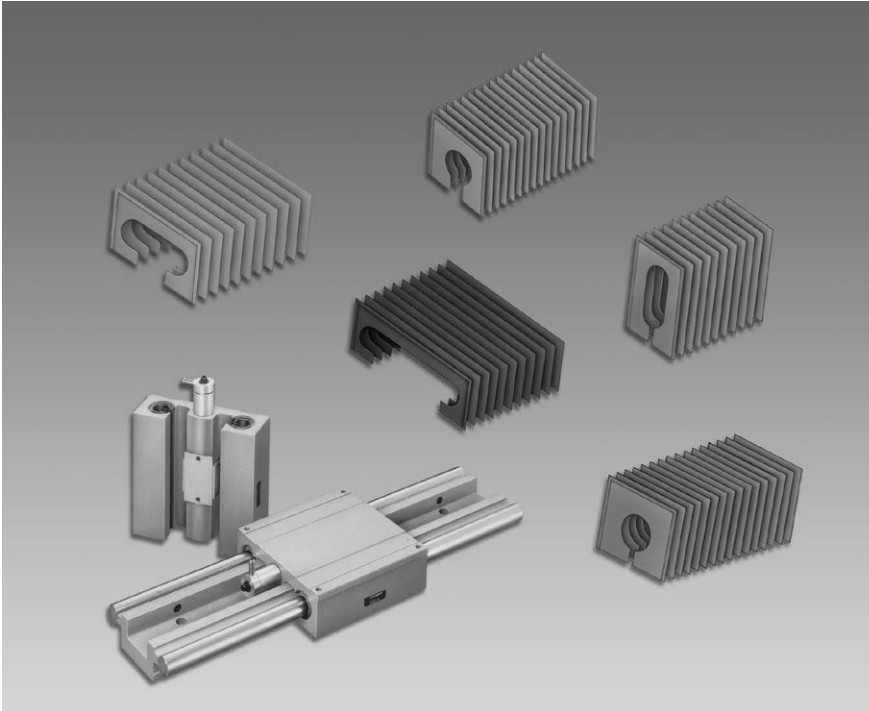

We offer a variety of accessories for the Thomson line of RoundRail Linear Guides.

- * Protective bellows are available on select models for applications where protection of the round rail guides and carriage bearings are required within harsh or dirty operating environments.
- * Some linear guide models are available with manually operated locking brakes for vertical applications and operations requiring unlimited carriage position alignment in the available range of stroke.
- * We encourage you to inquire about linear guide accessories not shown here or any custom application needs which you may have.

Collapsible Bellows

Bellows will reduce available stroke length of slide by approximately 28%.
Bellows P/N should be succeeded by a length when ordering.

- Bellows Materials:
- Polyester Cover
 - PVC Stiffeners

BEL-1B[†] (For 1BA) Moveable Protective Bellows (Dimensions in inches)

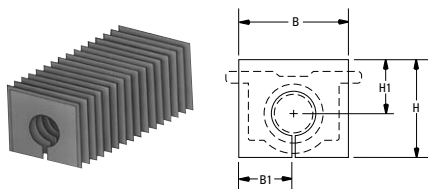

Part Number	Nominal Shaft Diameter	H	H1	B	CR
BEL-1B-04	1/4	1.187	.906	1.182	.163
BEL-1B-06	3/8	1.312	.968	1.937	.108
BEL-1B-08	1/2	1.687	1.156	2.062	.160
BEL-1B-12	3/4	2.000	1.156	2.312	.108
BEL-1B-16	1	2.375	1.281	2.625	.163
BEL-1B-24	1 1/2	3.062	1.531	3.125	.108

[†] Each moveable bellows comes with 1 section of bellows and 2 pairs of Velcro[®] Fasteners.

BEL-1C[†] (For 1CA) Moveable Protective Bellows (Dimensions in inches)

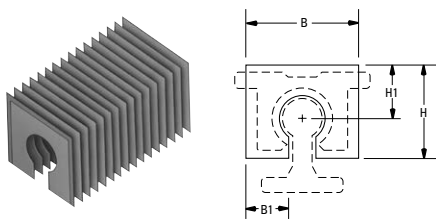

Part Number	Nominal Shaft Diameter	H	H1	B	CR
BEL-1C-08	1/2	1.375	.968	2.062	.088
BEL-1C-12	3/4	1.812	1.062	2.312	.120
BEL-1C-16	1	2.375	1.218	2.625	.088
BEL-1C-24	1 1/2	3.125	1.531	3.125	.088

[†] Each moveable bellows comes with 1 section of bellows and 2 pairs of Velcro[®] Fasteners.

BEL-2D (For QuickSlide System 2DA) Dual Shaft Rail Bellows (Dimensions in inches)

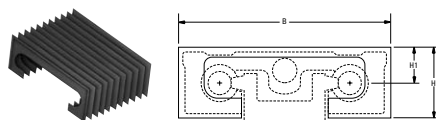

Part Number	Nominal Shaft Diameter	H	H1	B
BEL-2DA-08	1/2	1.50	.85	4.60
BEL-2DB-08	1/2	1.89	1.34	5.13
BEL-2D-12	3/4	2.406	1.437	6.00
BEL-2D-16	1	2.875	1.687	7.50

Each moveable bellows comes with 1 section of bellows and 2 mounting brackets and mounting screws.
[†] Appropriate arrangements for affixing the Bellows at each end of the QuickSlide 2DA System are required.

BEL-2C-H (For Horizontal Twin Shaft Web QuickSlide System 2CA) Moveable Protective Bellows (Dimensions in inches)

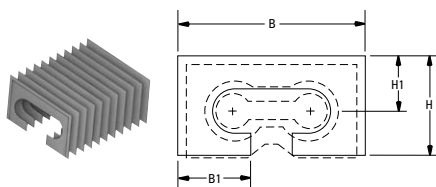

Part Number	Nominal Shaft Diameter	H	H1	B	CR
BEL-2C-08-H	1/2	1.688	1.031	3.250	.108
BEL-2C-12-H	3/4	2.062	1.156	3.812	.108
BEL-2C-16-H	1	2.437	1.281	4.62	.108

Each moveable bellows comes with 1 section of bellows and 2 pairs of Velcro[®] Fasteners.

BEL-2C-V (For Vertical Twin Shaft Web QuickSlide System 2CA) Dual Shaft Rail Bellows (Dim. in in.)

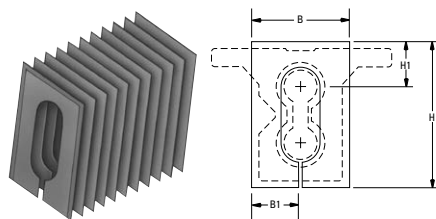

Part Number	Nominal Shaft Diameter	H	H1	B	CR
BEL-2C-08-V	1/2	2.750	1.000	2.125	.163
BEL-2C-12-V	3/4	3.750	1.125	2.375	.163
BEL-2C-16-V	1	4.375	1.250	2.625	.108

Each moveable bellows comes with 1 section of bellows and 2 pairs of Velcro[®] Fasteners.

Accessories

Table Tops

Carriage Top Plates for Linear Guides

1BA Mounting Table Top ⁽¹⁾ (Two mounting holes as shown in view A-A for sizes .250 and .375. Dim. in inches)

Nominal Diameter	All Table Tops					Table Top Size B					Table Top Size A				
	T	M	J	H6	F5	T1	J1	J4	J5	N	T2	J3	J4	J5	N1
.250	4.0	2.25	1.31	.250	#8-32	4.0	.75 (2)	.22	.22	3.50	2.50	2.00	.25	.22	2.0
.375	4.5	2.50	1.44	.250	#10-32	4.5	.88 (2)	.22	.28	3.75	2.75	2.25	.25	.28	2.0
.500	5.5	3.25	1.69	.375	1/4-20	5.5	1.00	.34	.28	4.50	3.50	2.50	.50	.31	2.5
.750	7.5	4.50	2.38	.500	5/16-18	7.5	1.25	.41	.31	6.00	4.50	3.50	.50	.31	3.0
1.000	9.0	5.50	2.88	.500	3/8-16	9.0	1.75	.53	.31	7.00	6.00	4.50	.75	.31	4.0
1.250	11.0	6.75	3.50	.750	1/2-13	11.0	2.00	.82	.38	8.50	7.50	5.50	1.00	.38	5.0
1.500	13.0	8.00	4.12	.750	1/2-13	13.0	2.50	.75	.44	10.00	9.00	6.50	1.25	.44	6.0

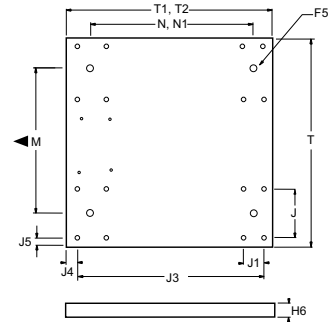

1NA Mounting Table Top ⁽²⁾ (Custom mounting hole. Dimensions in mm)

Nominal Diameter	All Table Tops					Table Top Size B					Table Top Size A					
	T	M	J	H6	F5	T1	J1	J4	J5	N	T2	J3	J4	J5	J9	N1
1NC-M08	85	50	25	10	M6	85	20	6,0	5,0	50	62	50	6	5,0	25	35
1NC-M12	100	55	32	10	M6	100	23	8,0	6,5	55	76	56	10	6,5	28	40
1NC-M16	125	70	40	13	M6	125	26	10,0	7,5	70	84	64	10	7,5	32	45
1NC-M20	175	110	45	16	M8	175	32	11,0	10,0	110	104	76	14	10,0	38	55
1NC-M25	225	140	60	20	M8	225	40	13,5	12,5	140	130	94	18	12,5	47	65
1NC-M30	275	180	68	20	M8	275	45	17,0	13,5	180	152	106	23	13,5	53	75
1NC-M40	325	210	86	25	M10	325	58	16,5	14,5	210	176	124	26	14,5	62	85

1CA Mounting Table Top ⁽¹⁾ (Dimensions in inches)

Nominal Diameter	All Table Tops					Table Top Size B					Table Top Size A				
	T	M	J	H6	F5	T1	J1	J4	J5	N	T2	J3	J4	J5	N1
.50	5.5	3.25	1.69	.375	1/4-20	5.5	1.00	.34	.28	4.5	3.5	2.5	.50	.31	2.5
.75	7.5	4.50	2.38	.500	5/16-18	7.5	1.25	.41	.31	6.0	4.5	3.5	.50	.31	3.0
1.00	9.0	5.50	2.88	.500	3/8-16	9.0	1.75	.53	.31	7.0	6.0	4.5	.75	.31	4.0
1.25	11.0	6.75	3.50	.750	1/2-13	11.0	2.00	.82	.38	8.5	7.5	5.5	1.00	.38	5.0
1.50	13.0	8.00	4.12	.750	1/2-13	13.0	2.50	.75	.44	10.0	9.0	6.5	1.25	.44	6.0

1PA Mounting Table Top ⁽²⁾ (Dimensions in mm)

Nominal Diameter	All Table Tops					Table Top Size B					Table Top Size A					
	T	M	J	H6	F5	T1	J1	J4	J5	N	T2	J3	J4	J5	J9	N1
PC-M12	100	55	32	10	M6	100	23	8,0	6,5	55	76	56	10	6,5	28	40
1PC-M16	125	70	40	13	M6	125	26	10,0	7,5	70	84	64	10	7,5	32	45
1PC-M20	175	110	45	16	M8	175	32	11,0	10,0	110	104	76	14	10,0	38	55
1PC-M25	225	140	60	20	M8	225	40	13,5	12,5	140	130	94	18	12,5	47	65
1PC-M30	275	180	68	20	M8	275	45	17,0	13,5	180	152	106	23	13,5	53	75
1PC-M40	325	210	86	25	M10	325	58	16,5	14,5	210	176	124	26	14,5	62	85

1VA Mounting Table Top ⁽¹⁾ (2 mounting holes as shown in view A-A for size .375. Dimensions in inches)

Nominal Diameter	All Table Tops					Table Top Size B					Table Top Size A				
	T	M	J	H6	F5	T1	J1	J4	J5	N	T2	J3	J4	J5	N1
.375	4.5	2.50	1.44	.250	#10-32	4.5	.88 (2)	.22	.28	3.75	2.75	2.25	.25	.28	2.0
.500	5.5	3.25	1.69	.375	1/4-20	5.5	1.00	.34	.28	4.50	3.50	2.50	.50	.31	2.5
.625	N/A	N/A	N/A	N/A	N/A	N/A	N/A	N/A	N/A	N/A	N/A	N/A	N/A	N/A	N/A
.750	7.5	4.50	2.38	.500	5/16-18	7.5	1.25	.41	.31	6.00	4.50	3.50	.50	.31	3.0
1.000	9.0	5.50	2.88	.500	3/8-16	9.0	1.75	.53	.31	7.00	6.00	4.50	.75	.31	4.0
1.250	11.0	6.75	3.50	.750	1/2-13	11.0	2.00	.82	.38	8.50	7.50	5.50	1.00	.38	5.0
1.500	13.0	8.00	4.12	.750	1/2-13	13.0	2.50	.75	.44	10.00	9.00	6.50	1.25	.44	6.0

1DA Mounting Table Top (Dimensions in inches)

Nominal Diameter	All Table Tops					Table Top Size D					Table Top Size C				
	T	M	J	H6	F5	T1	J1	J4	J5	N	T2	J3	J4	J5	N1 ⁽³⁾
.5	7.25	4.0	.91	.50	1/4-20	5.5	1.25	.25	.28	2.63	3.5	3.00	.25	.28	.75
.75	9.75	6.0	1.19	.50	5/16-18	7.5	1.58	.25	.38	3.50	4.5	4.00	.25	.38	1.00
1.00	12.00	6.0	1.44	.50	3/8-16	9.0	2.25	.34	.40	4.38	6.0	5.25	.38	.40	1.25

(1) Carriage material: Aluminum Alloy Black Anodized

(2) Carriage material: Aluminum Alloy Grey Anodized

(3) Mounting hole spacing facilitates attachment of Dual Shaft Rail 2DA Linear Guide in an X-Y orientation.

Accessories

2DA QuickSlide System with Brake

A manual locking mechanism for the Dual Shaft Rail System

2DA QuickSlide System with Brake offers:

- A manual locking mechanism with infinite positioning capability.
- No carriage mounting surface deflection when the locking mechanism is activated.
- Immediate off-the-shelf availability in 1/2, 3/4 and 1 inch sizes.
- A locking mechanism that, when activated, will not apply an increase in load on the system's Ball Bushing bearing.
- Zero axial movement during the activation of the locking mechanism.
- A fully supported Dual Shaft assembly for maximum rigidity and unlimited travel.
- High load capacity in any direction.

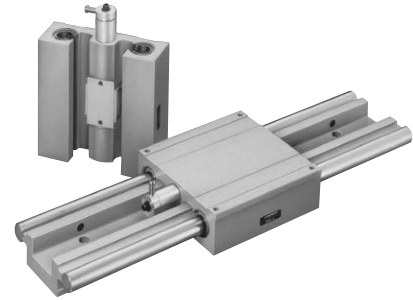

Dual Shaft Rail Fully Supported System with Integrated Carriage

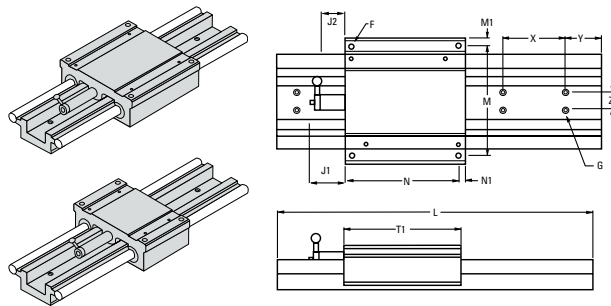

Dual Shaft Rail Supported Cross-Section

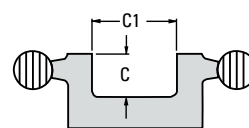

Maximum Stroke Length is determined by subtracting the carriage length (T1 or T2) plus the brake handle length (J1) from the total system length.

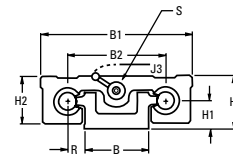

Dual Shaft Rail Fully Supported System with Integrated Carriage (Long Style) (Dimensions in inches)

Part Number	Nominal Shaft Diameter	Max. Load on System ⁽¹⁾ (lb.)	Max. Load on One Bearing ⁽¹⁾ (lb.)	T1	H	H1	H2	B	R	B1	B2	C	C1
2DA-08-00L	1/2	600	150	4.50	1.625	0.875	1.43	2.00	0.500	4.60	3.00	.64	1.25
2DA-12-00L	3/4	1880	470	6.00	2.125	1.125	1.93	2.63	0.688	6.10	4.00	.75	1.62
2DA-16-00L	1	3120	780	7.50	2.625	1.375	2.44	3.25	0.875	7.60	5.00	.99	2.00

(1) For rated travel life of 2 million inches. Note: Manual Brake can be adjusted in order to position handle to any radial location. Dual Shaft Rail Support Material: Aluminum Alloy Black Anodized. Standard length of one-piece Aluminum Dual Shaft Rails is 72".

Dual Shaft Rail Fully Supported System with Integrated Carriage (Long Style) (Dimensions in inches)

Part Number	N	N1	M	M1	X	Y	Z	J1	J2	J3	F	G		Max. Stroke Length	Carriage Part Number
												Bolt	Hole		
2DA-08-00L	4.00	.25	4.00	.30	4.00	2.00	.75	1.63	1.19	.88	#10-32	1/4	.28	L-(6.13)	DSRC-08-SL
2DA-12-00L	4.25	.37	5.25	.42	6.00	3.00	1.00	1.63	1.19	1.00	1/4-20	5/16	.34	L-(7.63)	DSRC-12-SL
2DA-16-00L	6.75	.37	6.75	.42	6.00	3.00	1.25	1.63	1.19	1.00	5/16-18	3/8	.41	L-(9.13)	DSRC-16-SL

Dual Shaft Rail Fully Supported System with Integrated Carriage (Short Style) (Dim. in inches)

Part Number	Nom. Shaft Diameter	T2	N2	Max. Stroke Length	Carriage Part Number
2DA-08-00M	1/2	3.50	3.00	L-(5.13)	DSRC-08-SM
2DA-12-00M	3/4	4.50	3.75	L-(6.13)	DSRC-12-SM
2DA-16-00M	1	6.00	5.25	L-(7.63)	DSRC-16-SM

System 2DA Standard Lengths (Dim. in inches)

System	8"	12"	16"	18"	20"	24"	28"	30"	32"	36"	40"	42"	44"	48"
2DA-08	•	•	•	•	•	•	•	•	•	•	•	•	•	•
2DA-12	•	•	•	•	•	•	•	•	•	•	•	•	•	•

Quick Slide Brake Holding Force

System	Axial Holding Force (lb.)
2DA-08	125
2DA-12	130
2DA-16	140

Custom Lengths and Delivery Information

Custom length systems are available. For special requirements, please contact the Thomson Systems application engineering department.

Engineering

Engineering



The Engineering Appendix contains valuable information on the application and use of Thomson Ball Bushing Bearings, pillow blocks, 60 Case LinearRace shafts, 60 Case LinearRace supports and accessories.

Engineering.....	262 - 281
Performance Criteria	263 - 264
Ball Bushing Life Expectancy and Load Capacity	267 - 268
60 Case* LinearRace* Shafting Specifications	269
Load Consideration	270
Coefficient of Friction.....	271
Lubrication	272
System Replacement Components.....	272
System Maintenance and Service	272
Bearing Options	273
Material Engineering Specifications.....	274
60 Case LinearRace Deflection	275
Ultra Light Aluminum LinearRace Deflection.....	276
How to Cut 60 Case LinearRace Shafting.....	277
Application Tips	278
Installation Guidelines	279
Tolerance Charts.....	280 - 281
Engineering Conversion Factors.....	281
Shafting Color Code Chart.....	283

Performance Criteria

The following performance criteria relates to the use, installation and specification of Thomson Ball Bushing Bearings. Each performance criteria plays an important role in maximizing system effectiveness and life.

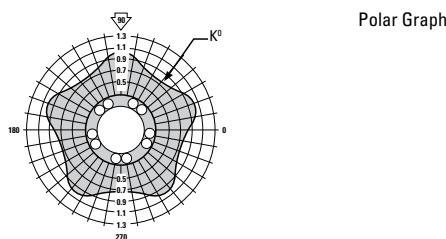
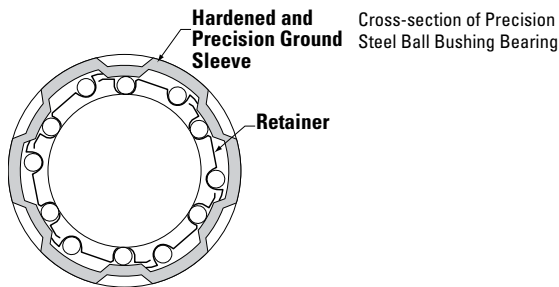
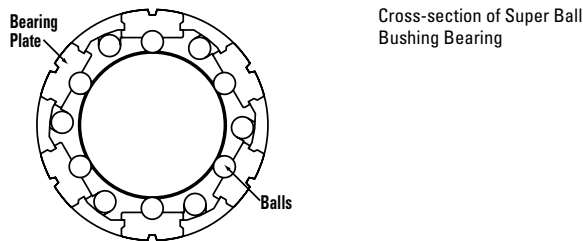
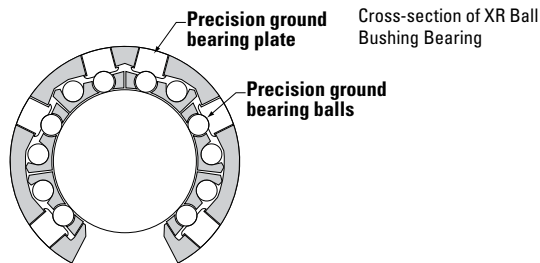
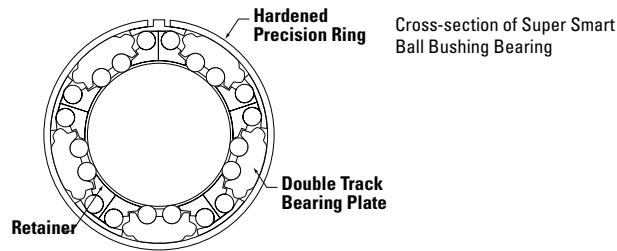

Dynamic Load Capacity

The Dynamic load capacity of a Ball Bushing Bearing is determined by the reaction between the rolling elements and the inner and outer race. The rolling elements in a Ball Bushing Bearing are a series of hardened and precision ground bearing balls. The inner race is a hardened and precision ground 60 Case LinearRace.

The outer race can be a hardened and precision ground, ball conforming, steel bearing plate or a hardened and precision ground steel bearing sleeve. The dynamic load capacity is also affected by the orientation of the ball tracks, the size of the balls, the shape of the ball conforming groove, the number of balls that are in load contact and more.

Since the introduction of the Ball Bushing Bearing in 1945, Thomson has designed and developed Ball Bushing Bearing products that have continuously achieved dramatic increases in dynamic load capacity and life. Our most recent innovation is the Super Smart Ball Bushing Bearing which has six times the dynamic load capacity or 216 times greater life than the traditional Ball Bushing Bearing.

This increase in load capacity was achieved by maximizing the load reaction between the inner and outer races. This break-through in load capacity rivals that of linear guides while still retaining the added benefits of the RoundRail Advantage enabling the linear bearing to avoid many of the derating factors that can diminish the load/life performance of square rail products.

The dynamic load capacity of all Thomson Ball Bushing Bearings is based on a L10 life of two million inches (100 km for Metric bearings) of travel. The dynamic load capacity can be affected by the orientation of the bearing with respect to the load or the direction of the applied load. A polar graph is included with each product specification to assist you in optimizing the load capacity as well as the performance of the Ball Bushing Bearing. To determine the resultant load capacity find the angle at which the load is applied to the bearing, and move in radially along that line until it intersects the curve. Move around circumferentially to the polar correction value located on the vertical axis. Next, multiply the proper correction factor by the dynamic load capacity listed in each product specification table.

Engineering

Performance Criteria (cont'd)

The RoundRail Advantage

The RoundRail Advantage is the inherent ability of a RoundRail bearing to accommodate torsional misalignment (caused by inaccuracies in carriage or base machining or by machine deflection) with little increase in stress to bearing components (Figure 1). This important feature to all Thomson Ball Bushing Bearing systems reduces installation time and cost, while maximizing performance.

Ball Bushing Bearing vs. Linear Guide

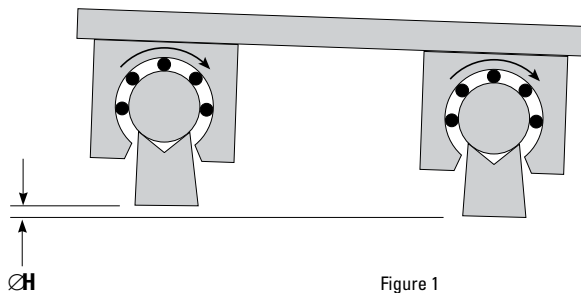

Figure 1

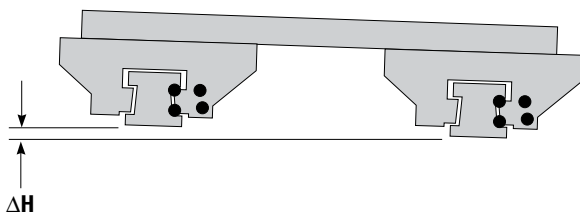

Figure 2

The major difference between a Ball Bushing Bearing and linear guide system is primarily in the design of the inner race. The linear guide inner race has two, four or six ground grooves that guide the carriage and the precision balls. Due to the ball conforming nature of the grooves, the carriage is prevented from accommodating torsional misalignment (Figure 2). If torsional misalignment is introduced to a linear guide system, the component stress increases, reducing life and performance. In a Ball Bushing Bearing system the inner race is a hardened and ground 60 Case LinearRace. Since there are no grooves, the Ball Bushing Bearing system can accommodate torsional misalignment and operate without added stress to bearing components.

60 Case LinearRace/Ball Bushing Bearing Fit-up

There are three basic fit-up conditions of a Ball Bushing Bearing and 60 Case LinearRace: clearance, line-to-line and preload. In most product sections there are specification tables that detail the Ball Bushing Bearing working bore diameter and 60 Case LinearRace diameter tolerance as well as the fit-up between them. The clearance, line-to-line and preload conditions are shown by the abbreviation C for clearance, P for preload and .0000 for a line-to-line condition.

Clearance

The clearance between a Ball Bushing Bearing and a 60 Case LinearRace is a result of the Ball Bushing Bearing working bore diameter and the diameter tolerance of the 60 Case LinearRace. The working bore diameter of a Super Smart or Super Ball Bushing Bearing is a function of the housing bore diameter tolerance. In applications where high accuracy and repeatability is not required, clearance is acceptable. Clearance can be achieved by following the recommended housing bore guidelines found in the product specification sections. To check for a clearance condition, rotate the 60 Case LinearRace inside the Ball Bushing Bearing while installed in a housing bore. If you can freely rotate the 60 Case LinearRace then a clearance condition is present. For more details see the product specification sections.

Preload

In applications where accuracy and repeatability are critical, the Super Smart, Super and Precision Steel Ball Bushing Bearings can be adjusted to a preload fit-up. The Super Smart and Super Ball Bushing Bearings are inherently adjustable and when installed in an adjustable housing bore a preload condition can be achieved. In a nonadjustable housing a preload condition can be obtained by making the size of the housing bore smaller or by increasing the diameter of the 60 Case LinearRace. To test for a preload condition in an adjustable or nonadjustable housing, simply rotate the 60 Case LinearRace inside the Ball Bushing Bearing while it is installed in the housing bore. If a slight drag is felt then a preload condition is present. When an adjustable housing is used the preload can be altered slightly. The Super Smart and Super Ball Bushing Bearing are more tolerant to preload than the Precision Steel Ball Bushing Bearing. Preload on a Super Smart and Super Ball Bushing Bearing should be a maximum of .001 inch per inch of 60 Case LinearRace diameter. Preload on a Precision Steel Ball Bushing Bearing should be a maximum of .0001 inch per inch of 60 Case LinearRace diameter. When all Ball Bushing Bearings are preloaded, extra care must be taken in mounting the 60 Case LinearRace parallel.

Line-to-Line

A line-to-line fit-up condition between a Ball Bushing Bearing and 60 Case LinearRace is when no clearance or preload is present. A line-to-line fit-up can be achieved in an adjustable or fixed diameter housing. For more details see the product specification sections.

Examples of Ball Bushing Bearing/60 Case LinearRace Fit-ups (in.)

Ball Bushing Bearing Part Number	Working Bore Diameter	Recommended Housing Bore Diameter (fixed)	Actual Working Bore Diameter	60 Case LinearRace Diameter	Ball Bushing Bearing/60 Case LinearRace Fit Up
SUPER 20	1.2500/1.2494	2.0008/2.0000	1.2508/1.2494	1.2495/1.2490	.0018C/.0001P
A-203242	1.2500/1.2494	—	1.2500/1.2494	1.2490/1.2485	.0015C/.0004C
XA-203242	1.2500/1.2496	—	1.2500/1.2496	1.2495/1.2490	.0010C/.0001C

Engineering

The new Super Smart Ball Bushing Bearing represents a major advancement in linear bearing technology worldwide. The Super Smart Ball Bushing Bearing offers twice the load capacity or eight times the travel life of the industry standard Super Ball Bushing Bearing. An enormous technological breakthrough, considering the Super Ball Bushing Bearing already offers three times the load capacity or twenty-seven times the travel life of conventional Ball Bushing Bearings.

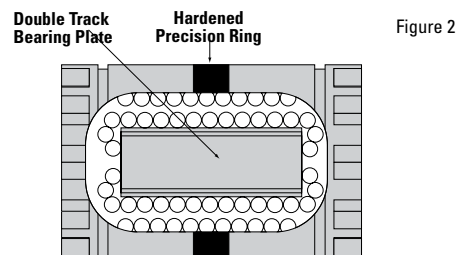
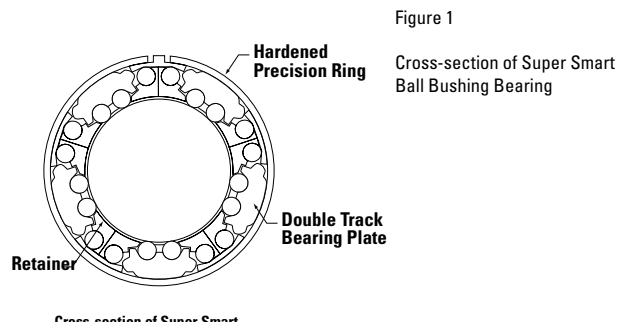

Technologically Advanced Design

The load carrying component of the Super Smart Ball Bushing Bearing is the combination of four hardened bearing quality steel components (Figures 1 & 2).

The first component is the hardened precision outer ring, which enables the bearing to maintain its diametral fit-up even after extended use, when standard self-aligning bearing plates would imbed into the housing. The unique ring design also allows for bearing adjustment and the removal of diametral clearance. The second component is the precision super finished double track bearing plate that provides twice the load capacity and in combination with the hardened precision steel band provides true universal self-alignment; which means optimum performance even with slight installation imperfections including housing bore out of roundness..

The third component is the rolling element. Each Super Smart Ball Bushing Bearing features precision ground balls manufactured to the highest quality standards for roundness and sphericity. The result is maximum load capacity, travel life and performance.

The last component is the 60 Case LinearRace shaft that functions as the inner race to the Super Smart Ball Bushing Bearing. Each 60 Case LinearRace is manufactured to the highest quality standards for roundness, straightness, surface finish and hardness. Roundness is held under .000080"; straightness to .001" per 12"; surface finish under 8 Ra and hardness between 60-65 HRC. The combination of inner and outer race or 60 Case LinearRace and Super Smart Ball Bushing Bearing provides the fullest embodiment of the RoundRail Advantage.

Engineering

Self-Alignment

The Super Smart and Super Ball Bushing Bearings are equipped with a built-in self-alignment feature that allows the bearing to absorb misalignment up to 0.5° per inch (Figure 3 and 4). This self-aligning feature allows the Super Smart and Super Ball Bushing Bearing to absorb misalignment caused by inaccuracies in housing bore alignment or 60 Case LinearRace deflection.

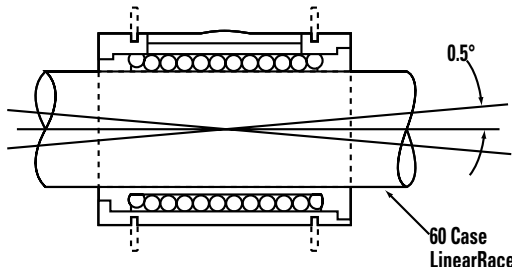

Figure 3
Super Ball Bushing Bearing Self-Alignment Feature

This rocking capability also provides smooth entry and exit of the precision balls into and out of the load zone assuring a constant low coefficient of friction. By compensating for misalignment, each bearing ball in the load carrying area is uniformly loaded providing maximum load capacity. Besides this rocking capability, only the Super Smart Ball Bushing Bearing provides two additional self-alignment features. They are Roll and Yaw.

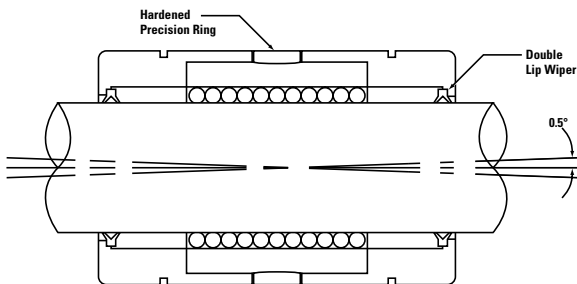

Figure 4
Super Smart Ball Bushing Bearing Self-Alignment Feature

Roll

The Super Smart Ball Bushing Bearing plate is designed with the radius of its outer surface smaller than the inside radius of the precision outer ring (Figure 5). This feature allows the bearing plate to compensate minor torsional misalignment still distribute the load on each of its two ball tracks. The roll component assures maximum load capacity and travel life.

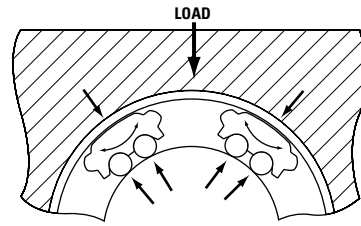

Figure 5
Super Smart Ball Bushing Bearing Self-Alignment Feature

Yaw

The shape formed by the Rock and Roll features enables the Super Smart Ball Bushing Bearing plate to even rotate about its center (Figure 6). This allows the Super Smart Ball Bushing Bearing to also absorb skew caused by misalignment. The result is a constant low coefficient of friction and maximum bearing performance.

Figure 7 below describes the conditions to which Super Smart and Super Ball Bushings automatically self-align. It is important to note that even though the Super Smart and Super Ball Bushing Bearings self-align, they still cannot absorb an out-of-parallel 60 Case LinearRace condition. Tolerance to 60 Case LinearRace out-of-parallelism is a function of clearance between the bearing and its 60 Case LinearRace.

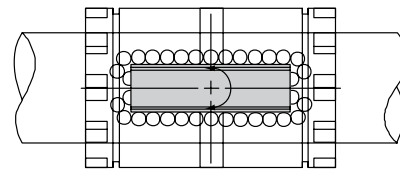

Figure 6
Bearing plates rotate about their center to prevent skewing relative to the 60 Case LinearRace.

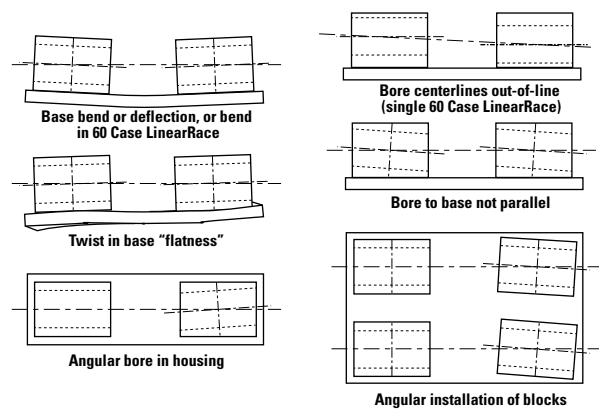

Figure 7

Ball Bushing Bearing Life Expectancy and Load Capacity

There are many factors that affect Ball Bushing Bearing travel life such as 60 Case LinearRace hardness, the resultant load, the direction of the resultant load and Ball Bushing Bearing orientation. The dynamic load capacities and travel life graphs given in the specification tables found in each product section are based on a load applied at 90° relative to the horizontal plane with the Ball Bushing Bearing oriented as shown in each corresponding polar graph. Note: For Super Smart Ball Bushing Bearings and other extremely high load bearings, the bearing load capacity as indicated by the polar charts may be practically limited by the degree of shaft flexure acceptable, or the capacity of the shaft rail assembly fasteners. In such cases, the loads should be kept below these practical limits, however, the full corresponding life capacity benefits are still realized! The dynamic load capacity is also based on using only Thomson specified 60 Case LinearRace that is hardened to HRC 60 to 65.

For considerations other than those described above, the following formula is used:

$$W_R = \frac{P}{K_0 \cdot K_S \cdot K_L}$$

Where:

- W_R = required dynamic load capacity (lb, or N)
- P = resultant of externally applied loads (lb_t or N)
- K_0 = factor for direction of resultant load
- K_S = shaft hardness factor (Equals 1.0 for 60 Case LinearRace)
- K_L = load correction factor

Travel Life

The load correction factor, K_L , can be found from Figure 1 for inch product, and Figure 2 for Metric product. To determine K_L for your required travel life, look for the value on the horizontal axis – Travel Life Factor – left side of the chart. (Interpolate as necessary – this is a Log-Log curve.) That is the value of your load correction factor.

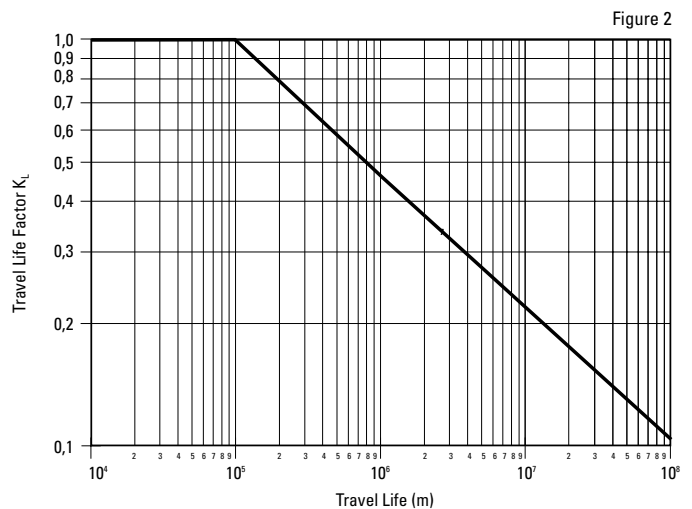
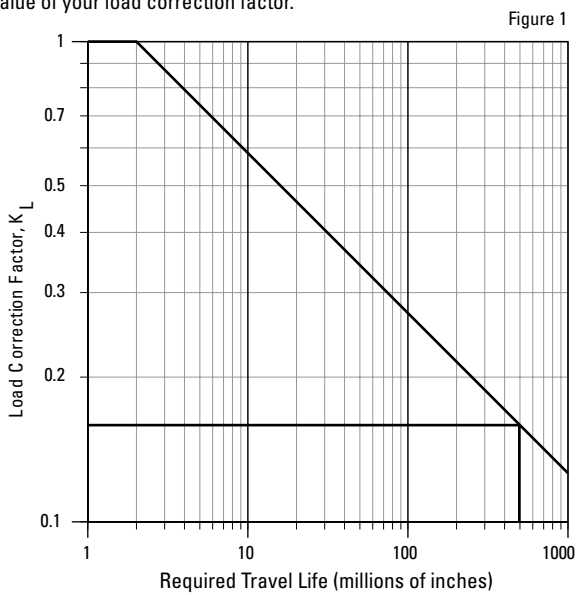

60 Case LinearRace Hardness

For shafts that do not meet 60 Case LinearRace hardness specifications of 60 HRC, shaft hardness factor K_S must be applied. To determine K_S , simply enter Figure 3 with your shaft Rockwell hardness, find the value on the horizontal axis – Shaft Hardness – bottom of chart. Move vertically up until you intersect the curve. Then move horizontally until you reach the vertical axis – Shaft Correction Factor – left side of chart.

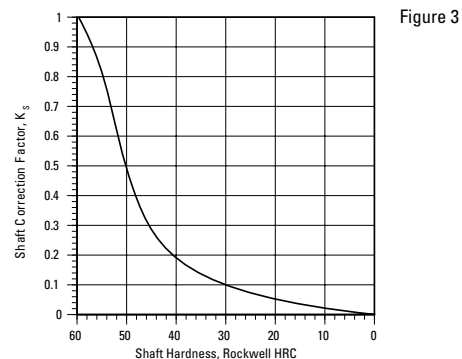

Engineering

Load Direction

In applications where the direction of the applied load is known, refer to the polar graphs on the product specification pages for the orientation factor (load correction factor is K_L). A polar graph is referenced in Figure 4 for example.

Once you have determined your required dynamic load capacity refer to the product specification table for the proper Ball Bushing Bearing size. Note: For Super Smart Ball Bushing bearings and other extremely high load bearings, the bearing load capacity as indicated by the polar charts may be practically limited by the degree of shaft flexure acceptable, or the capacity of the shaft rail assembly fasteners. In such cases, the loads should be kept below these practical limits, however, the full corresponding life capacity benefits are still realized!

Note: Thomson Linear Ball Bushing Bearings are precision components.

To preserve bearing warranty you must use the specified Thomson 60 Case LinearRace.

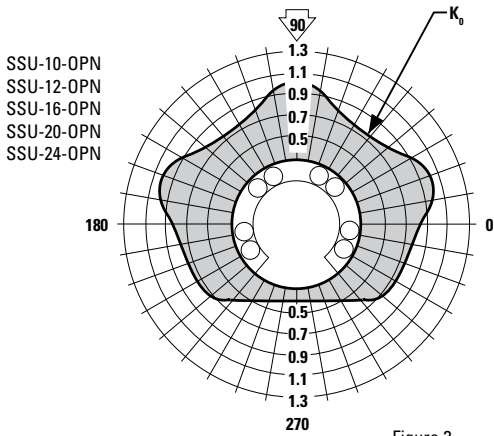

Figure 3

Load Limit

The load limit is the maximum load which can be applied to the bearing. It is important to analyze your application so that peak and shock loading does not exceed the load limit.

Dynamic Load Rating

The dynamic load rating is the maximum continuous load that can be applied to the bearing with a 90% reliability of achieving life of two million inches (100 km for Metric bearings) under conventional operating conditions. However, it is important to remember that very short strokes and the direction of the applied load can be significant factors.

The following formula may be used to determine travel life for Metric bearings (SSEM, SPM, and MAM):

$$L_m = \left(\frac{W}{P} \cdot K_o \cdot K_s \right)^3 \cdot 10^6 \text{m}$$

Where: L_m = travel life (m)
 W = dynamic load rating from tables (N)
 P = resultant from externally applied loads (N)
 K_o = factor for direction of resultant load
 K_s = shaft hardness factor

Sample Calculations:

Determine the correct Ball Bushing Bearing size for your application. In this example, the bearing/shaft system is subjected to a load of 2300 N perpendicular to the direction of travel. The load is distributed equally among four closed type MultiTrac Ball Bushing Bearings. The carriage reciprocates over a 0,3 m stroke at a frequency of 100 complete cycles per minute. The minimum service life required is 3500 hours. 60 Case LinearRace shafting is used.

The first step is to determine the average load on each Ball Bushing Bearing.

$$P = \frac{W}{P} = 575 \text{ N}$$

Next, determine the equivalent travel life in meters:

$$\begin{aligned} L_m &= 2 \cdot s \cdot f \cdot L_h \cdot 60 \\ L_m &= 2 \cdot 0,3 \cdot 100 \cdot 3500 \cdot 60 \\ L_m &= 1,26 \cdot 10^7 \text{m} \end{aligned}$$

Where: s = stroke in meters
 f = frequency in cycles per minute
 L_h = required life in hours

From Figure 1 (Travel Life Chart), the travel life factor (K_L) is 0,2.

From Figure 2 (Shaft Hardness Chart), the shaft hardness factor (K_s) is 1.

For closed type MultiTrac Ball Bushing Bearings, the minimum value of K_o is 1, the assumed value for this calculation.

The required dynamic load capacity is obtained by using the following formula:

$$W_R = \frac{P}{K_L \cdot K_s \cdot K_o} \quad W_R = \frac{575}{0,2 \cdot 1 \cdot 1} = 2875 \text{ N}$$

By referring to the product specification and dimension sections of this catalog, the linear bearing with the next higher load capacity is the MultiTrac MA M40 with a dynamic load capacity of 3820 N.

Determining the Travel Life

The expected travel life of the MultiTrac MA M40 bearing under the conditions described in the example is:

$W = 3820 \text{ N}$ is the rated dynamic load capacity
 $P = 575 \text{ N}$ is resultant of external loads
 $K_o = 1$ is the orientation factor
 $K_s = 1$ is the shaft hardness factor

The values are substituted into the following formula:

$$L_m = \left(\frac{W}{P} \cdot K_o \cdot K_s \right)^3 \cdot 10^6 \text{m} \quad L_m = \left(\frac{3820}{575} \cdot 1 \cdot 1 \right)^3 \cdot 10^6 \text{m}$$

$$L_m = 293 \cdot 10^6$$

$$\text{This is converted into hours by the following: } L_h = \frac{293 \cdot 10^6}{2 \cdot 60 \cdot 0,3 \cdot 100}$$

$$L_h = 8139 \text{ h}$$

60 Case LinearRace Shafting Specifications

Thomson 60 Case LinearRace provides the inner race for Thomson Ball Bushing Bearings. All 60 Case LinearRace is manufactured to extremely close tolerances for surface finish, roundness, hardness and straightness to provide long service life with reduced maintenance.

Specifications

- Hardness: HRC 60 minimum
- Surface Finish: 8 R_a microinch
- Roundness: 80 millionths of an inch
- Straightness: Standard—.001 inch per foot cumulative (.002 TIR)
Special—.0005 inch per foot cumulative (.001 TIR)
- Length Tolerance: Standard $\pm .030$ inch for diameters up to 2 inches and $\pm .060$ for diameters 2 inch and over. Special length tolerances available.
- Chamfer: Standard chamfer on diameters up to 1 inch is .030 x 45° and .060 x 45° for diameters larger than 1 inch.
- Tensile Strength: Case: 335,000 psi, Core: 100,000 psi
- Yield Strength: Case: 250,000 psi, Core: 75,000 psi

Load Factor

In applications where the applied load exceeds 70% of the maximum dynamic load capacity of Super Smart Ball Bushing Bearings, a high load correction factor K_f must be applied to W_R when calculating travel life. (Figure 1)

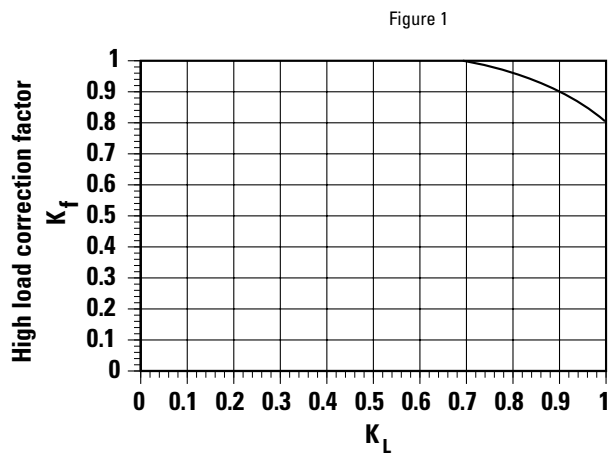

Short Stroke Applications

In applications when the stroke length is short, the life of the shaft is shorter than that of the Ball Bushing Bearing. In short stroke applications, the required dynamic load capacity must be multiplied by the factor K_c found on Figure 2.

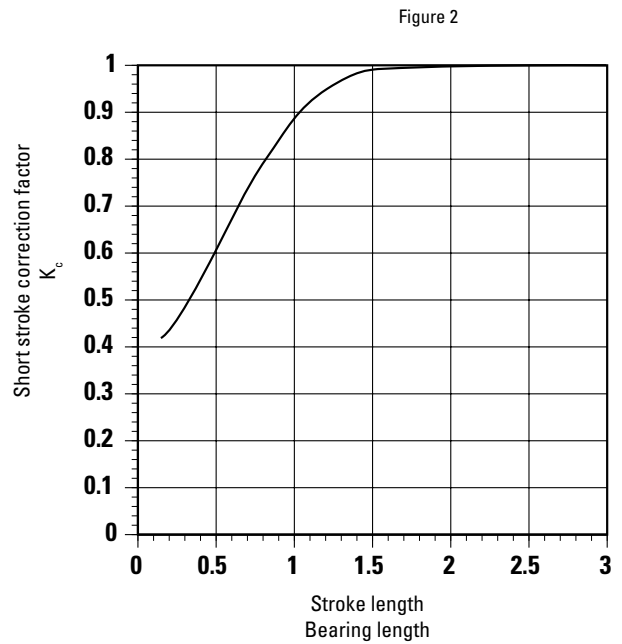

Engineering

Load Consideration

When designing a linear motion system it is necessary to consider how the variables of operation will affect performance.

The following examples demonstrate how the position of the load and the center of gravity can influence the product selection. When evaluating your application, review each of the forces acting on your system and determine the product best for your needs.

Terms:

- d_0 = distance between centerlines of pillow blocks
- d_1 = distance between centerlines of 60 Case LinearRace ways (recommended spacing on d_1 is no more than 3x the d_0 distance)
- d_2 = distance from centerline of carriage to load action point
- d_3 = distance from centerline of carriage to load action point
- W = Load (lb)
- F_{NX} = Force in the X-axis direction (lb_f or N)
- F_{NY} = Force in the Y-axis direction (lb_f or N)
- F_{NZ} = Force in the Z-axis direction (lb_f or N)

$$F_{1z} = \frac{W}{4} + \left(\frac{W}{2} \cdot \frac{d_2}{d_0} \right) - \left(\frac{W}{2} \cdot \frac{d_3}{d_1} \right)$$

$$F_{2z} = \frac{W}{4} - \left(\frac{W}{2} \cdot \frac{d_2}{d_0} \right) - \left(\frac{W}{2} \cdot \frac{d_3}{d_1} \right)$$

$$F_{3z} = \frac{W}{4} - \left(\frac{W}{2} \cdot \frac{d_2}{d_0} \right) + \left(\frac{W}{2} \cdot \frac{d_3}{d_1} \right)$$

$$F_{4z} = \frac{W}{4} + \left(\frac{W}{2} \cdot \frac{d_2}{d_0} \right) + \left(\frac{W}{2} \cdot \frac{d_3}{d_1} \right)$$

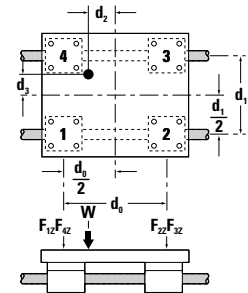

Horizontal Application I

At the time of movement with uniform velocity or at the time of stop.

$$F_{1z} = \frac{W}{4} + \left(\frac{W}{2} \cdot \frac{d_2}{d_0} \right) - \left(\frac{W}{2} \cdot \frac{d_3}{d_1} \right)$$

$$F_{2z} = \frac{W}{4} - \left(\frac{W}{2} \cdot \frac{d_2}{d_0} \right) - \left(\frac{W}{2} \cdot \frac{d_3}{d_1} \right)$$

$$F_{3z} = \frac{W}{4} - \left(\frac{W}{2} \cdot \frac{d_2}{d_0} \right) + \left(\frac{W}{2} \cdot \frac{d_3}{d_1} \right)$$

$$F_{4z} = \frac{W}{4} + \left(\frac{W}{2} \cdot \frac{d_2}{d_0} \right) + \left(\frac{W}{2} \cdot \frac{d_3}{d_1} \right)$$

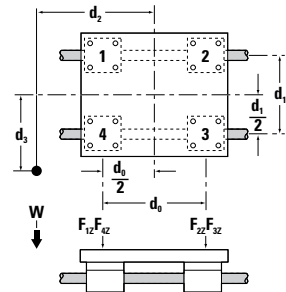

Horizontal Application II

At the time of movement with uniform velocity or at the time of stop.

$$F_{1Y} \cong F_{4Y} = \left(\frac{W}{2} \cdot \frac{d_3}{d_1} \right)$$

$$F_{1z} = F_{4z} = \frac{W}{4} + \left(\frac{W}{2} \cdot \frac{d_2}{d_0} \right)$$

$$F_{2z} = F_{3z} = \frac{W}{4} - \left(\frac{W}{2} \cdot \frac{d_2}{d_0} \right)$$

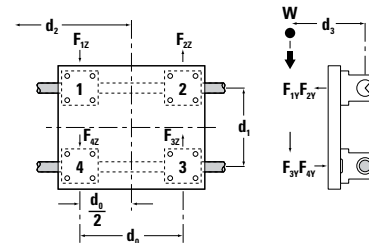

Side Mounted Application

At the time of movement with uniform velocity or at the time of stop.

$$F_{1X} \cong F_{4X} = \frac{W}{2} \cdot \frac{d_2}{d_0}$$

$$F_{1Y} \cong F_{4Y} = \frac{W}{2} \cdot \frac{d_3}{d_0}$$

$$F_{1X} + F_{4X} \cong F_{2X} + F_{3X}$$

$$F_{1Y} + F_{4Y} \cong F_{2Y} + F_{3Y}$$

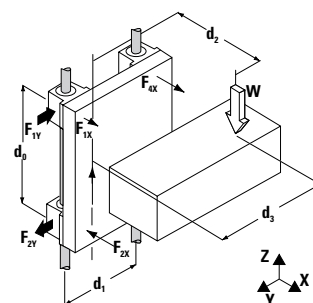

Vertical Application

At the time of movement with uniform velocity or at the time of stop. At the time of start and stop, the load varies because of inertia.

Coefficient of Friction

The coefficient of friction of Thomson Ball Bushing Bearings ranges from 0.001 to 0.004. There are two components of the coefficient of friction: the rolling or operating friction and the static or breakaway friction.

Coefficient of Rolling Friction

The rolling coefficient of friction is measured by the force required to operate the Ball Bushing at a constant rate of travel. The formula for determining frictional resistance during operation is as follows:

$$P_f = P \times f_r$$

Where,

P_f = Frictional resistance (lb_f)

P = Resultant of externally applied loads (lb_f)

f_r = Coefficient of rolling friction

The following table describes the coefficient of rolling friction of Ball Bushing Bearings operating on Thomson 60 Case LinearRace. These values are grouped according to the number of ball circuits in each bearing. Friction coefficients are constant among bearings having three and four ball circuits, but slightly less for bearings with five or six ball circuits. A dry Ball Bushing Bearing has the lowest coefficient of friction due to the complete absence of lubricant surface tension effects. Values for grease lubrication ranges from 100% greater in the smaller sizes to 20% to 50% greater in the larger sizes. Oil lubrication (medium/heavy, viscosity 64 cs @ 100°F / 38°C) achieves frictional values slightly higher than those for grease lubrication.

Ball Bushing Bearing coefficients of rolling friction (f_r)

Bearing I.D.	Number of Ball Circuits	Condition of Lubrication	Load in % of Rolling Load Rating (for 2,000,000 inches of travel)				
			125%	100%	75%	50%	25%
1/4, 3/8, 1/2, 5/8	3 & 4	No Lube	.0011	.0011	.0012	.0016	.0025
		Grease Lube	.0019	.0021	.0024	.0029	.0044
		Oil Lube	.0022	.0023	.0027	.0032	.0045
3/4, 1	5	No Lube	.0011	.0011	.0012	.0015	.0022
		Grease Lube	.0018	.0019	.0021	.0024	.0033
		Oil Lube	.0020	.0021	.0023	.0027	.0036
1 1/4 thru 1	6	No Lube	.0011	.0011	.0012	.0014	.0019
		Grease Lube	.0016	.0016	.0017	.0018	.0022
		Oil Lube	.0018	.0018	.0019	.0021	.0027
5/8 thru 1 1/2	10	No Lube	.0011	.0011	.0012	.0013	.0018
		Grease Lube	.0014	.0014	.0015	.0016	.0019
		Oil Lube	.0016	.0016	.0017	.0019	.0025

Coefficient of Static Friction

The coefficient of static or breakaway friction is measured by the force required to initiate Ball Bushing Bearing movement. The formula used to determine static frictional resistance is:

$$P_f = P \times f_0$$

where f_0 = Coefficient of static friction

The values for the coefficient of static friction or breakaway friction are not measurably affected by the number of ball circuits in the bearing or by the lubrication condition.

Ball Bushing Bearing coefficients of static friction (f_0)

Load in % of Rolling Load Rating				
125%	100%	75%	50%	25%
.0028	.0030	.0033	.0036	.0040

Seal Drag

Another variable that affects the frictional resistance in a Ball Bushing Bearing system is seal drag. When seals are used to retain lubricant or to prevent entry of foreign particles, frictional resistance must be taken into account for determining total frictional drag. In applications where contamination is minimal, the seals can be removed to reduce frictional drag. In highly contaminated applications, seals, wipers and or scrapers are used to minimize the ingress of contamination into the bearing. This protective measure adds to the frictional drag of the bearing system. There is a fine line between minimizing frictional drag and maximizing contaminant protection which is controlled by the addition or removal of seals, wipers or scrapers. In applications that require low frictional drag in highly contaminated environments, contact Thomson application engineering.

Thomson can provide a specially formulated lubricant, specifically developed to meet a broad range of linear bearing applications. Thomson LinearLube lubricant is a synthetic lubricant that utilizes suspended Teflon® in a specially formulated compound. LinearLube lubricant provides excellent performance characteristics in a wide range of applications. It is FDA listed, non-polluting and non-corrosive. LinearLube lubricant will not stain and adheres tightly to parts forming a virtually water resistant barrier.

- Maintains properties in operating temperatures from -65°F to 450°F / -54°C to 232°C
- USDA Rated HL (Non-Toxic)
- Will not oxidize in use
- 100% water resistant

Engineering

System Replacement Components

Replacement components for systems are available from Thomson. Assure the accuracy and repeatability of your system by specifying a -XS after the component part number.

Thomson Linear Motion systems are designed and manufactured through advanced processes with high grade materials chosen for their strength, durability, and hardness. The following is a comprehensive list of the materials utilized throughout Thomson systems.

System Maintenance and Service

All Thomson ball-Bushing Bearings require a small amount of grease or oil to operate. For general applications, EP2 (extreme pressure NLGI grade2) lubricant is recommended to prevent wearing and rusting of the bearing surfaces. For food grade applications, Linear Lube (teflon-based synthetic grease) is recommended. When linear speeds are high, light oil should be used and the bearing should be prevented from running dry for a prolonged period of time. A medium to heavy oil or light grease has greater adhesion properties that afford longer bearing protection and minimize sealing problems.

All Thomson ball-Bushing Bearings are shipped with rust preventative oil. It is recommended that you lubricate the ball bushing prior to installation and periodically during operation to assure that the ball bushing does not run dry. Bearing lube cycle not to exceed 1 year or 100 km of travel (whichever comes first), but more frequent application may be required based on duty cycle, usage, environment and level of contamination. Thomson can provide a specially formulated lubricant, specifically developed to meet a broad range of linear bearing applications. Thomson LinearLube lubricant is a synthetic lubricant that utilizes suspended Teflon® in a specially formulated compound. LinearLube lubricant provides excellent performance characteristics in a wide range of applications. It is FDA listed, non-polluting and non-corrosive. LinearLube lubricant will not stain and adheres tightly to parts forming a virtually water resistant barrier.

- Maintains properties in operating temperatures from -65°F to 450°F / -54°C to 232°C
- USDA Rated HL (Non-Toxic)
- Will not oxidize in use
- 100% water resistant

Bearing Options

Ball Options

- CR Corrosion Resistant: This option is available on all Super and Super Smart bearings and pillow blocks. The option provides stainless steel balls and plated bearing plates. For Super Smart, the outer band is also plated. Using stainless steel balls will reduce the dynamic load capacity by 30%.
- SS Stainless Steel: This option is available for metal A bearings and MultiTrac metric (MAM) bearings. The option provides stainless steel instead of carbon steel and stainless steel balls. For A bearings, this available up to and including 1" sizes, for MAM bearings, this option is available for all sizes except 40mm. Using stainless steel balls will reduce the dynamic load capacity by 30%.
- SP Stainless Steel Balls, Black Oxide Retainer and Sleeve: This option is available for all metal A bearings and MultiTrac metric (MAM) bearings, and is a good alternative to –SS. Using stainless steel balls will reduce the dynamic load capacity by 30%.
- NB Nylon Balls: This option provides full nylon balls in place of carbon steel balls. Resulting in a very quiet bearing, but reducing the load capacity by 90%. Available on all bearings
- NBA Alternating Nylon Balls: This option is useful when a more quiet than standard bearing is desired, but full nylon is not needed. This will reduce dynamic load capacity by 50%. Available on all bearings

Lube Options

- LL Bearing is lubricated at the factory with Thomson Linear Lube
- L4L Pillow block furnished with a Lube for Life cartridge on each end. This option is available on Super & Super Smart inch pillow blocks, sizes ½", ¾", 1", 1 ¼" & 1 ½".
- DP Bearing is shipped with no lubricant at all. (Typically all ball bearings are shipped with rust preventative only.)

Other Options

- RP The Roll Pack option eliminates the packing box. This may be desired on larger quantity orders.
- HP The bearing is treated with a Black Oxide finish. This option is available on metal A bearings and MultiTrac metric (MAM) bearings.

*Up to 1 option per option category can be selected. (Example, A162536-SPLLRP)

Engineering

Material Engineering Specifications

Ball Bushing Bearing materials

The following is a tabulation of the materials used for the components of the various types of Ball Bushing Bearings

Type	Outer Sleeve	Ball Retainers	Bearing Plates	Balls	End Rings/ Band
SSU, SSJM, SSEM, SPM, SUPER Ball Bushing Bearings	Delrin	Delrin	52100	Chrome Steel	None/ Steel
Series A, B, XA, ADJ, OPN and DS	52100	Steel	–	Chrome Steel	Steel
Stainless Steel (SS) to 1" I.D. Series A, XA, ADJ and OPN	440A	Type 305SS	–	440C	Type 303SS
Series MAM	–	Delrin	–	Chrome Steel	Steel
Series INST-SS	440C	Brass	–	440C	None
Series XR	Reinforce Nylon	Reinforce Polyester	8620	Chrome Steel	Steel

Note: Materials called out are typical, certain series and sizes may vary.

Corrosion Resistance

Super and Super Smart Ball Bushing Bearings can be supplied corrosion resistant with hard chrome plated bearing plates and stainless steel balls. Load capacity will be 70% of regular Super Ball Bushing Bearings. To order, add suffix "CR" following the Super Ball Bushing Bearing part number.

Large sizes (over 1" diameter) of series A, XA, ADJ, OPN and B, Ball Bushing Bearings can be supplied with stainless steel balls and black oxide sleeves for limited protection against atmospheric corrosion. Load capacity will be 70% of regular steel bearings. To order, add suffix "SP" following the bearing part number.

Stainless Steel Ball Bushing Bearings

Precision and Multitrack Ball Bushing Bearings can be supplied with stainless steel ball and end rings. To order, add suffix "SS" following the bearing part number. Precision bearings are made entirely of stainless steel components. Multitrack bearings have stainless steel balls, end rings and outer sleeves.

Sizes available:

Series A and XA: 1/4", 3/8", 1/2", 5/8", 3/4" and 1"

Series ADJ and OPN: 1/2", 5/8", 3/4" and 1"

Series MAM: 8mm, 12mm, 16mm, 20mm, 25mm, 30mm

Ball Bushing Bearings with nylon balls

For extremely quiet operation, Ball Bushing Bearings fitted with Nylon balls can be supplied in sizes 1/2" and larger. For estimating purposes load ratings should be considered about 10% of those listed for Ball Bushing Bearings with steel balls. Prices and other information available on request.

NBA bearings have a load rating of 50% listed dynamic.

60 Case shafts – hardened and ground

Material Type	AISI	Rockwell "C"
Solid 60 Case	Bearing-quality, high carbon alloy steel	60 min
Tubular 60 Case	Bearing-quality, high carbon alloy steel	58 min
Solid Stainless Steel	440C Stainless	50 min

Maximum recommended operating temperatures for RoundRail Bearings

The following are general recommendations. For additional information or more specific recommendations please contact factory with full application details.

Type of Ball Bushing Bearings	Maximum Operating Temperature	Load Rating at Maximum Operating Temperature as % of Catalog Load Rating
Series Super Smart, Super, MultiTrac & XR	185°F / 85°C	100%
Series A, B, XA, ADJ & OPN; Series DS, and Series RW S, V, A, B & C	500°F / 260°C	70%
Series A-SS, XA-SS, ADJ-SS, OPN-SS & INST-SS Stainless Steel (through 1" I.D.)†	600°F / 316°C	60%

†Maximum operating temperature for these two series for full catalog load rating is 300°F/149°C.

‡Note: Type PB-A, PB-ADJ, and PBO-OPN pillow blocks are assembled with Delrin plastic seal covers with a maximum operating temperature at 185°F.

- For extreme minimum temperatures, contact Engineering.
- Seals max temperature is 250°F / 121°C
- Shafting loses 5 points hardness for every 100°F / 38°C above 200°F / 93°C.

Pillow blocks and shaft supports

Part Type	Material
Type Super Smart and Super – Pillow Blocks, Flanged Blocks and Aluminum Shaft Blocks	Type 6061-T6511 Aluminum
Type PB pillow blocks	Ductile Iron
Type PBO & XPBO pillow blocks	Malleable/Ductile Iron
Type SR shaft support rails (std. lgth. 24")	Type 6061-T6511 Aluminum
Type LSR shaft support rails	1010 Steel
Type XSR shaft support rails (std. lgth. 24")	Ductile Iron
Type SB shaft support blocks	Malleable Iron††
Waymount shaft supports	Malleable Iron Base with steel adjustment elements

††Type 6061-T6511 Aluminum for 1/4" and 3/8" sizes only

	Components	Material
Supports	Type ASB End Support	Aluminum Alloy †
	Type SB End Support	Iron
	Type SRA End Support	Aluminum Alloy †
	Twin Shaft End Support	Aluminum Alloy †
	Twin Shaft Web End Support	Aluminum Alloy †
	Integrated End Support	Aluminum Alloy †
	Dual Shaft Support Rail	Aluminum Alloy †
Carriage	Inner Race (60 Case™ Shafting)	Case Hardened High Carbon Steel
	Universal Carriage	Aluminum Alloy †
	Twin Shaft Carriage	Aluminum Alloy †
	Twin Shaft Web Carriage	Aluminum Alloy †
	Modular Dual Shaft Carriage	Aluminum Alloy †
	Integrated Dual Shaft Carriage	Aluminum Alloy †

† Custom Black Anodized for inch size systems. Custom Grey Anodized for metric size systems. Custom system lengths may require black paint to protect machine cut-off ends on Dual Shaft Rail Assemblies and Shaft support Rails. If a specific surface finish is required contact the Thomson Systems application engineering department.

†† Limited to a Max. Temperature of 185°F / 85°C

60 Case LinearRace Deflection

When Thomson 60 Case LinearRace is used in an end supported configuration it is important to ensure that 60 Case LinearRace deflections at the bearing locations are kept within performance limitations.

These equations give the deflection at the center of an end supported 60 Case LinearRace. Systems with continuous 60 Case LinearRace support are not subject to the same types of deflection.

For more detailed information of the deflection characteristics of Thomson linear motion products contact application engineering.

Simply Supported 60 Case LinearRace with One Block

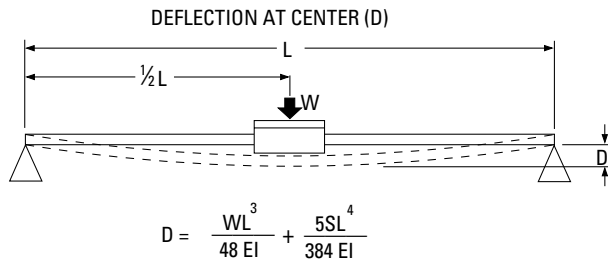

Simply Supported 60 Case LinearRace with Two Blocks

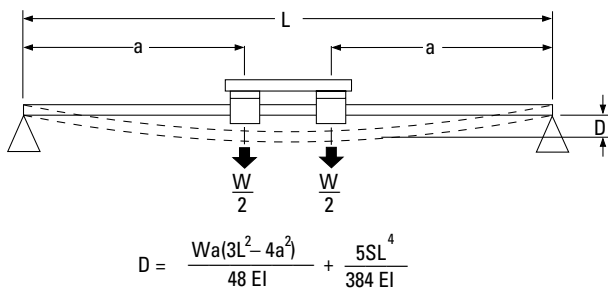

LEGEND:

- D** = (in) (m)
- W** = (lb_f) (N)
- L** = (in) (m)
- a** = (in) (m)
- S** = (lb_f/in) (N/m)
- E** = (lb_f/in²) (N/m²)
- I** = (in⁴) (m⁴)

Values for Thomson 60 Case LinearRace

LinearRace Diameter (In)	Solid		Tubular	
	EI (lb _f • in ²)	Weight (S) (lb _f / in)	EI (lb _f • in ²)	Weight (S) (lb _f / in)
.187	1.8E+03	.008	—	—
.250	5.8E+03	.014	—	—
.375	2.9E+04	.031	—	—
.500	9.2E+04	.055	—	—
.625	2.3E+05	.086	—	—
.750	4.7E+05	.125	4.6E+05	.075
1.000	1.5E+06	.222	1.3E+06	.158
1.250	3.6E+06	.348	—	—
1.500	7.5E+06	.500	6.3E+06	.328
2.000	2.4E+07	.890	1.9E+07	.542
2.500	5.8E+07	1.391	4.2E+07	.749
3.000	1.2E+08	2.003	9.3E+07	1.112
4.000	3.8E+08	3.560	2.5E+08	1.558

LinearRace Diameter (mm)	EI (N • m ²)	Weight (S) (N / m)
5mm	5.838	0.0016
8mm	38.26	0.0038
10mm	93.41	0.0061
12mm	193.7	0.0087
16mm	612.2	0.0154
20mm	1495	0.0240
25mm	3649	0.0379
30mm	7566	0.0542
40mm	2.391E+04	0.0968
50mm	5.838E+04	0.1513
60mm	1.211E+05	0.2172
80mm	3.826E+05	0.3870

Deflection for Twin Shaft Web System

Since the Twin Shaft Web rail has different stiffness depending on its orientation, an appropriate EI value must be used based upon the direction of loading. Select the orientation of your load from the figure below and then use the appropriate EI value in the deflection equation.

Shaft Diameter (in)	EI Horizontal (lb _f • in ²)	EI Vertical (lb _f • in ²)
1/2	1.9E+05	3.7E+06
3/4	9.4E+05	1.5E+07
1	3.0E+06	4.7E+07

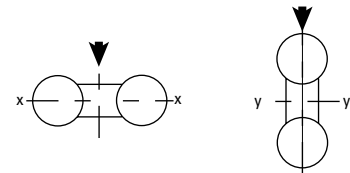

Engineering

Ultra Light Aluminum LinearRace Deflection

Simply Supported 60 Case LinearRace with One Block

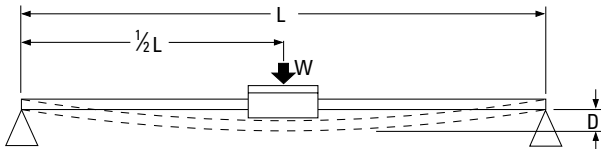

$$D = \frac{WL^3}{48EI} + \frac{5SL^4}{384EI}$$

Nominal Diameter (in)	EI (lbf • in ²)
1/4	1.92+03
3/8	9.79+03
1/2	3.13+04
5/8	7.50+04
3/4	1.56+05
1	5.00+05

Simply Supported 60 Case LinearRace with Two Blocks

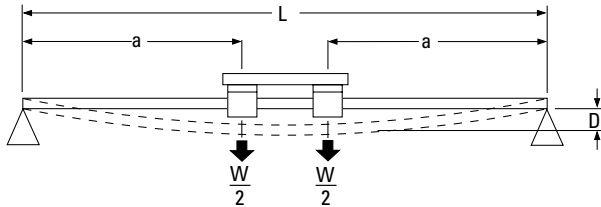

$$D = \frac{Wa(3L^2 - 4a^2)}{48EI} + \frac{5SL^4}{384EI}$$

LEGEND:

- D = (in) (m)
- W = (lb_f) (N)
- L = (in) (m)
- a = (in) (m)
- S = (lb_f/in) (N/m)
- E = (lb_f/in²) (N/m²)
- I = (in⁴) (m⁴)

How to Cut 60 Case LinearRace Shafting

Genuine 60 Case LinearRace shafting has an extremely hard outer surface, HRC 60, and a soft core. The following steps will guide you in cutting 60 Case shafts. Remember: Always use goggles and normal shop safety precautions.

With an abrasive cut-off saw. . . (preferred method)

Step 1:
Mark the shaft at the desired length.

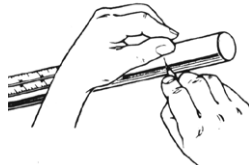

Step 2:
Secure shaft in vise with longer end clamped.

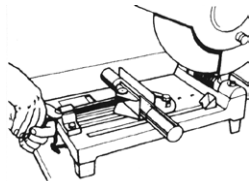

Step 3:
Cut the shaft at the mark.

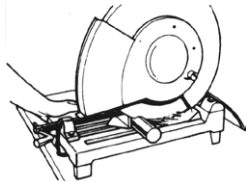

Step 4:
Chamfer the shaft by rotating it by hand while holding it against an abrasive wheel at approximately 45°. Use an emery cloth to remove burrs and discoloration.

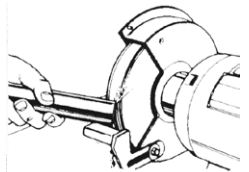

With a lathe. . . (using a collect type or standard 3-jaw chuck)

Step 1:
Mark the shaft at the desired length.

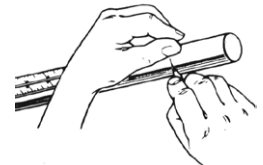

Step 2:
Secure shaft in lathe with longer end in spindle.

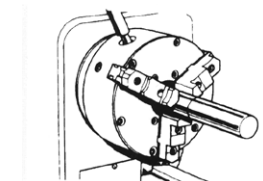

Step 3:
Use a sharp, carbide cut-off tool with shaft turning at approx. the following speeds: 400 rpm for dia. 1/4" - 1", and 300 rpm for dia. 1" or larger

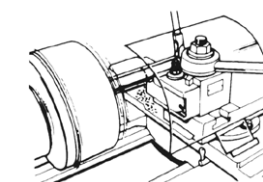

Step 4:
Chamfer the shaft using a standard carbide turning tool or an abrasive wheel. Use an emery cloth to remove burrs and discoloration.

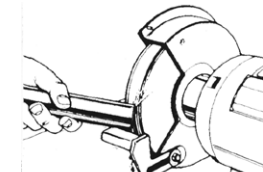

Engineering

Application Tips

Two Ball Bushing Bearings per 60 Case LinearRace

When using the Super Smart, Super or Precision Steel Ball Bushing Bearing it is recommended that two Ball Bushings bearings be used on each 60 Case LinearRace. This will assure system stability as well optimum performance. If envelope constraints prohibit the use of two Ball Bushing Bearings per 60 Case LinearRace contact application engineering.

Ball Bushing Bearing Spacing vs. 60 Case LinearRace Spacing

In parallel 60 Case LinearRace applications, the ratio of 60 Case LinearRace spacing to Ball Bushing Bearing spacing should always be less than three to one. This will assure a constant breakaway and operating friction.

60 Case LinearRace Parallelism

In most applications the maximum acceptable out of parallelism condition is .001 inch over the entire full system length. In applications where preload is present (such as when using Die Set Ball Bushing Bearings) a closer 60 Case LinearRace parallelism is recommended.

Three or More Parallel 60 Case LinearRace Ways

When aligning two 60 Case LinearRace ways parallel great care is required to assure a parallelism within .001 inch over the entire length of travel. When aligning multiple 60 Case LinearRace ways, parallelism between each 60 Case LinearRace should be held within the .001 inch specification.

Measuring 60 Case LinearRace Alignment

Methods for establishing or checking 60 Case LinearRace straightness and parallelism depends on the accuracy required. Lasers, collimator or alignment telescopes can be used for very precise applications, while accurate levels, straight edges, micrometers and indicators will suffice for the majority of applications which have less stringent accuracy requirements.

Installation of Super and Precision Steel Adjustable Type Ball Bushing Bearings

When installing a Super Ball Bushing Bearing into a slotted adjustable housing, the bearing plate should not align with the adjustment slot. When installing a Precision Steel Adjustable Type Ball Bushing Bearing into a slotted adjustable housing, the bearing adjustment slot should be 90° to the pillow block adjustment slot. These important steps will assure accurate bearing adjustment.

Access for Lubrication

Thomson Super Smart and Super Ball Bushing Pillow Blocks are equipped with either an oil lubrication fitting or a 1/4-28 access for lubrication. To use the oil fitting simply insert a lubrication device into the oil nipple by depressing the spring loaded ball. The 1/4-28 tapped hole is a standard size for most grease and lubrication fittings. Simply install the lubrication fitting of your choice and it is ready for immediate use. Super Ball Bushing Pillow blocks in sizes .250 through .500 inch diameter are equipped with oil lubrication fittings. Super Ball Bushing pillow blocks in sizes .625 inch and above and all Super Smart Ball Bushing Pillow Blocks are equipped with a 1/4-28 access for lubrication. Metric Super Smart Pillow Blocks are equipped with a M6X1 access for lubrication.

Waymount Support Block for Roundway Bearing Installation

Standard Waymount LinearRace Support Blocks provide 60 Case LinearRace adjustment in both the horizontal and vertical direction. This

product reduces installation time dramatically, while assuring precise 60 Case LinearRace alignment. This versatile design allows the

Waymount support to be mounted vertically or horizontally and in many different Roundway bearing applications. The number of Waymounts to be used is based on the maximum allowable 60 Case LinearRace deflection between supports and the accuracy required. Ordinarily indicators, sensitive levels and straight edges are adequate for most alignment conditions.

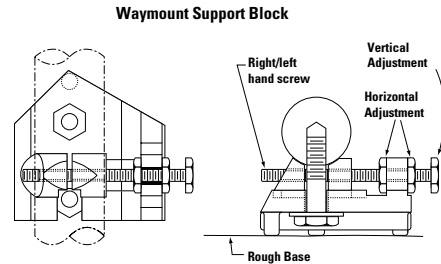

Roundway Bearing/60 Case LinearRace Installation Using Grout

Grouting is a very simple method of mounting a 60 Case LinearRace on almost any kind of surface, smooth or uneven. Grouting can also be used in conjunction with standard Waymount LinearRace support blocks or other 60 Case LinearRace supports to obtain maximum rigidity. Dams are fastened to the bed parallel to the 60 Case LinearRace which is then aligned with its mating 60 Case LinearRace (Figure 1). A compound is then poured under and around the lower circumference of the 60 Case LinearRace. This dries quickly forming a solid support of high compressive strength (over 12,000 psi) without affecting the initial straightness of the LinearRace.

If the bearing arrangement permits the grout to flow substantially around the circumference of the 60 Case LinearRace and side loads are light, Waymount LinearRace supports or other hold down bolts along the length made be unnecessary (Figure 2). Just one support at each end of the 60 Case LinearRace will usually provide final alignment and hold the 60 Case LinearRace in position for grouting. If the length to diameter ratio is large, Waymount LinearRace supports should be equally spaced to minimize 60 Case LinearRace deflection. Grout should always be in direct contact with the surface of the bed or whatever base member provides primary rigidity and support.

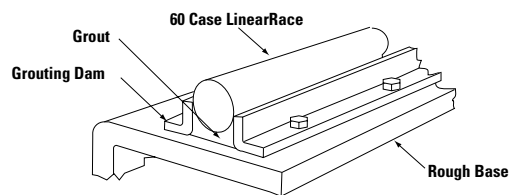

Figure 1

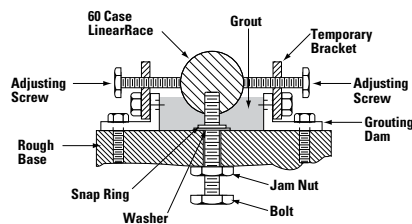

Figure 2

Installation Guidelines

Thomson Ball Bushing bearings are manufactured to exceptionally close tolerances and offer smooth, virtually friction-free motion. The performance features of the bearings will only be realized, however, if care is taken during their installation.

Two areas of primary importance are the bearings alignment and the shaft parallelism. Two bearings are normally used on each shaft to assure smooth operation. The housing should be carefully aligned using the method given below. If a single twin-type housing is used, these procedures are not necessary. It is also necessary to assure that the height from the housing mounting surface to the shaft is consistent within .001 inch. Shimming may be necessary depending on the accuracy of the mounting surfaces to which the housings are bolted.

The housing can be mounted to the plate using the following procedure:

- Prepare the carriage plate with one side having an abutting surface.
- Mount two housings with the reference edges located against the abutting surface and tighten the hold down bolts. Figure #1
- Mount the second pair of housings on the opposite side of the carriage and tighten the bolts finger tight.
- Insert a locating shaft of correct diameter and tolerance (h6) through these two housings and reference the distance from the abutting surface in [b] above, to this locating shaft. Figure #2
- After appropriate alignment of this pair of housings, tighten bolts to secure housings to carriage.

After the carriage is properly prepared, the shafts must be mounted to the surface. To achieve smooth, accurate motion, the shafts must be mounted parallel within .001 inch over the length of the stroke. This can be done by using the following procedure:

- Mount one shaft (either end-supported or fully supported) to the surface with mounting bolts finger tight.
- Using an aligning device such as a laser, auto-collimator or other optics, sight the shaft straight and secure to mounting surface.
- After this first shaft is fixed, the second shaft can be positioned and held down with bolts finger tight.
- The carriage is then mounted and its movement will pull this second shaft parallel to the first. Figures #3 and #4
- If the second shaft is then secured into position, the procedure is complete. Note that for fully supported systems, this securing should be done when the carriage is close to the bolts. For end supported systems, the securing should be done when the carriage is at the ends of the shafts. Figure #5
- An additional check can be done at this time to assure that the carriage is tracking correctly (i.e., that the carriage edge is moving parallel to the shaft). An indicator touching the carriage edge should not vary, as the carriage is moved along the shafts. Figure #6

Figure 1

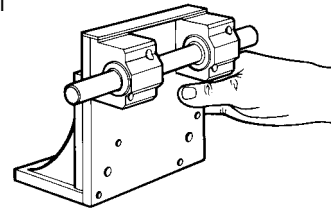

Figure 2

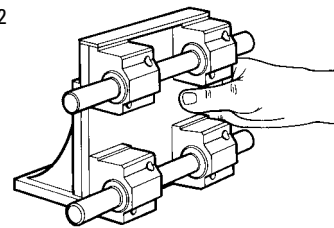

Figure 3

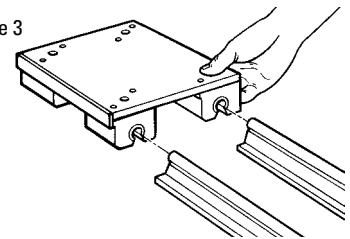

Figure 4

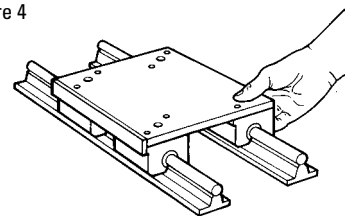

Figure 5

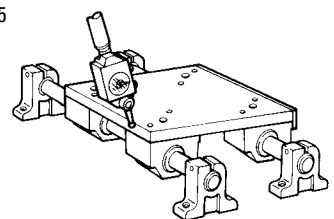
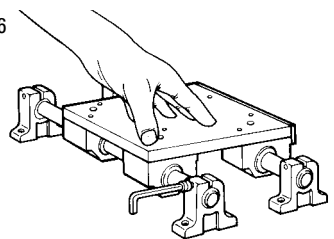

Figure 6



Engineering

Tolerance Charts

Tolerance zones for internal (hole) dimensions (H15 through H5) (Dimensions in mm)

Basic Size	H15	H14	H13	H12	H11	H10	H9	H8	H7	H6	H5
Over 6	+0,580	+0,360	+0,220	+0,150	+0,090	+0,058	+0,036	+0,022	+0,015	+0,009	+0,006
To 10	0,000	0,000	0,000	0,000	0,000	0,000	0,000	0,000	0,000	0,000	0,000
Over 10	+0,700	+0,430	+0,270	+0,180	+0,110	+0,070	+0,043	+0,027	+0,018	+0,011	+0,008
To 14	0,000	0,000	0,000	0,000	0,000	0,000	0,000	0,000	0,000	0,000	0,000
Over 14	+0,700	+0,430	+0,270	+0,180	+0,110	+0,070	+0,043	+0,027	+0,018	+0,011	+0,008
To 18	0,000	0,000	0,000	0,000	0,000	0,000	0,000	0,000	0,000	0,000	0,000
Over 18	+0,840	+0,520	+0,330	+0,210	+0,130	+0,084	+0,052	+0,033	+0,021	+0,013	+0,009
To 24	0,000	0,000	0,000	0,000	0,000	0,000	0,000	0,000	0,000	0,000	0,000
Over 24	+0,840	+0,520	+0,330	+0,210	+0,130	+0,084	+0,052	+0,033	+0,021	+0,013	+0,009
To 30	0,000	0,000	0,000	0,000	0,000	0,000	0,000	0,000	0,000	0,000	0,000
Over 30	+1,000	+0,620	+0,390	+0,250	+0,160	+0,100	+0,062	+0,039	+0,025	+0,016	+0,011
To 40	0,000	0,000	0,000	0,000	0,000	0,000	0,000	0,000	0,000	0,000	0,000
Over 40	+1,000	+0,620	+0,390	+0,250	+0,160	+0,100	+0,062	+0,039	+0,025	+0,016	+0,011
To 50	0,000	0,000	0,000	0,000	0,000	0,000	0,000	0,000	0,000	0,000	0,000
Over 50	+1,200	+0,740	+0,460	+0,300	+0,190	+0,120	+0,074	+0,046	+0,030	+0,019	+0,013
To 65	0,000	0,000	0,000	0,000	0,000	0,000	0,000	0,000	0,000	0,000	0,000
Over 65	+1,200	+0,740	+0,460	+0,300	+0,190	+0,120	+0,074	+0,046	+0,030	+0,019	+0,013
To 80	0,000	0,000	0,000	0,000	0,000	0,000	0,000	0,000	0,000	0,000	0,000
Over 80	+1,400	+0,870	+0,540	+0,350	+0,220	+0,140	+0,087	+0,054	+0,035	+0,022	+0,015
To 100	0,000	0,000	0,000	0,000	0,000	0,000	0,000	0,000	0,000	0,000	0,000
Over 100	+1,400	+0,870	+0,540	+0,350	+0,220	+0,140	+0,087	+0,054	+0,035	+0,022	+0,015
To 120	0,000	0,000	0,000	0,000	0,000	0,000	0,000	0,000	0,000	0,000	0,000
Over 120	+1,600	+1,000	+0,630	+0,400	+0,250	+0,160	+0,100	+0,063	+0,040	+0,025	+0,018
To 140	0,000	0,000	0,000	0,000	0,000	0,000	0,000	0,000	0,000	0,000	0,000
Over 140	+1,600	+1,000	+0,630	+0,400	+0,250	+0,160	+0,100	+0,063	+0,040	+0,025	+0,018
To 160	0,000	0,000	0,000	0,000	0,000	0,000	0,000	0,000	0,000	0,000	0,000
Over 160	+1,600	+1,000	+0,630	+0,400	+0,250	+0,160	+0,100	+0,063	+0,040	+0,025	+0,018
To 180	0,000	0,000	0,000	0,000	0,000	0,000	0,000	0,000	0,000	0,000	0,000
Over 180	+1,850	+1,150	+0,720	+0,460	+0,290	+0,185	+0,115	+0,072	+0,046	+0,029	+0,020
To 200	0,000	0,000	0,000	0,000	0,000	0,000	0,000	0,000	0,000	0,000	0,000

Tolerance zones for external LinearRace shaft dimensions (h15 through h5) (Dimensions in mm)

Basic Size	h15	h14	h13	h12	h11	h10	h9	h8	h7	h6	h5
Over 6	0,000	0,000	0,000	0,000	0,000	0,000	0,000	0,000	0,000	0,000	0,000
To 10	-0,580	-0,360	-0,220	-0,150	-0,090	-0,058	-0,036	-0,022	-0,015	-0,009	-0,006
Over 10	0,000	0,000	0,000	0,000	0,000	0,000	0,000	0,000	0,000	0,000	0,000
To 14	-0,700	-0,430	-0,270	-0,180	-0,110	-0,070	-0,043	-0,027	-0,018	-0,011	-0,008
Over 14	0,000	0,000	0,000	0,000	0,000	0,000	0,000	0,000	0,000	0,000	0,000
To 18	-0,700	-0,430	-0,270	-0,180	-0,110	-0,070	-0,043	-0,027	-0,018	-0,011	-0,008
Over 18	0,000	0,000	0,000	0,000	0,000	0,000	0,000	0,000	0,000	0,000	0,000
To 24	-0,840	-0,520	-0,330	-0,210	-0,130	-0,084	-0,052	-0,033	-0,021	-0,013	-0,009
Over 24	0,000	0,000	0,000	0,000	0,000	0,000	0,000	0,000	0,000	0,000	0,000
To 30	-0,840	-0,520	-0,330	-0,210	-0,130	-0,084	-0,052	-0,033	-0,021	-0,013	-0,009
Over 30	0,000	0,000	0,000	0,000	0,000	0,000	0,000	0,000	0,000	0,000	0,000
To 40	-1,000	-0,620	-0,390	-0,250	-0,160	-0,100	-0,062	-0,039	-0,025	-0,016	-0,011
Over 40	0,000	0,000	0,000	0,000	0,000	0,000	0,000	0,000	0,000	0,000	0,000
To 50	-1,000	-0,620	-0,390	-0,250	-0,160	-0,100	-0,062	-0,039	-0,025	-0,016	-0,011
Over 50	0,000	0,000	0,000	0,000	0,000	0,000	0,000	0,000	0,000	0,000	0,000
To 65	-1,200	-0,740	-0,460	-0,300	-0,190	-0,120	-0,074	-0,046	-0,030	-0,019	-0,013
Over 65	0,000	0,000	0,000	0,000	0,000	0,000	0,000	0,000	0,000	0,000	0,000
To 80	-1,200	-0,740	-0,460	-0,300	-0,190	-0,120	-0,074	-0,046	-0,030	-0,019	-0,013
Over 80	0,000	0,000	0,000	0,000	0,000	0,000	0,000	0,000	0,000	0,000	0,000
To 100	-1,400	-0,870	-0,540	-0,350	-0,220	-0,140	-0,087	-0,054	-0,035	-0,022	-0,015
Over 100	0,000	0,000	0,000	0,000	0,000	0,000	0,000	0,000	0,000	0,000	0,000
To 120	-1,400	-0,870	-0,540	-0,350	-0,220	-0,140	-0,087	-0,054	-0,035	-0,022	-0,015
Over 120	0,000	0,000	0,000	0,000	0,000	0,000	0,000	0,000	0,000	0,000	0,000
To 140	-1,600	-1,000	-0,630	-0,400	-0,250	-0,160	-0,100	-0,063	-0,040	-0,025	-0,018
Over 140	0,000	0,000	0,000	0,000	0,000	0,000	0,000	0,000	0,000	0,000	0,000
To 160	-1,600	-1,000	-0,630	-0,400	-0,250	-0,160	-0,100	-0,063	-0,040	-0,025	-0,018
Over 160	0,000	0,000	0,000	0,000	0,000	0,000	0,000	0,000	0,000	0,000	0,000
To 180	-1,600	-1,000	-0,630	-0,400	-0,250	-0,160	-0,100	-0,063	-0,040	-0,025	-0,018
Over 180	0,000	0,000	0,000	0,000	0,000	0,000	0,000	0,000	0,000	0,000	0,000
To 200	-1,850	-1,150	-0,720	-0,460	-0,290	-0,185	-0,115	-0,072	-0,046	-0,029	-0,020

Engineering

QUANTITY	CONVENTIONAL		SI Unit	Conversion Factors
	Inch Unit	Metric Unit (MKS)		
LENGTH	Inch in.	Meter m	Metre m	1 in. = 25.4 mm
				1 mm = 0.03937 in.
				1 m = 3.2808 ft.
				1 ft. = 0.3048 m
AREA	Square Inch in. ²	Square Meter m ²	Square Metre m ²	1 in. ² = 6.4516 cm ²
				1 cm ² = 0.155 in. ²
				1 m ² = 10.764 ft ²
MASS	Pound lb _m	Kilogram kg	Kilogram kg	1 ft. ² = 0.092903 m ²
				1 lb _m = 0.45359237 kg
				1 kg = 2.2046 lb
FORCE	Pound Force lb _f	Kilogram Force kg _f	Newton N	1 lb _f = 0.45359237 kg _f
				1 lb _f = 4.44822 N
				1 kg _f = 2.2046 lbf
				1 kg _f = 9.80665 N
				1 N = 0.1019716 kg _f
STRESS or PRESSURE	Pounds per square inch lb _f /in. ²	Kilograms per square meter kg _f /m ²	Pascal Pa	1 N = 0.224809 lb _f
				1 MPa = 10 ⁶ N/m ² = N/mm ²
				1 kPa = 10 ³ N/m ²
				1 lb _f /in. ² = 0.070307 kg _f /cm ²
				1 lb _f /in. ² = 7.0307 x 10 ⁻⁴ kg _f /mm ²
				1 lb _f /in. ² = 6.8947 x 10 ⁻³ N/mm ² (MPa)
TORQUE or WORK	Inch Pounds lb _f -in.	Kilogram Meters kg _f -m	Newton- Metres Nm	1 kg _f /cm ² = 14.2233 lb _f /in. ²
				1 kg _f /cm ² = 9.80665 x 10 ⁻² N/mm ² (MPa)
				1 lbf-in. = 1.1521 kg _f -cm
				1 kg _f -cm = 0.8679 lb _f -in.
				1 lb _f -in. = 0.1129848 Nm
				1 kg _f -m = 9.80665 Nm
POWER	Foot pound per minute lb _f -ft./min.	Force per second kg _f -m/s	Newton Metre per second Nm/s	1 N = 10.19716 kg _f
				1 kg _f -cm = 9.80665 x 10 ⁻² Nm
				1 Nm = 8.85 lb _f -in.
				1 Nm = 10.19716 kg _f -cm
				1 kW = 1000Nm/s
				1 kW = 60,000 Nm/s
VELOCITY	Feet per second ft./s	Meters per second m/s	Meters per second m/s	1 kW = 44,220 lb _f -ft./min.
				1 kW = 1.341 hp
				1 hp = 75 kg _f -m/s
				1 hp = 44,741 Nm/min.
				1 hp = 33,000 lb _f -ft.min.
				1 hp = 0.7457 kW
ACCELERATION	Feet per second squared ft./s ²	Meters per second squared m/s ²	Metres per second squared m/s ²	1 ft./sec. = 0.3048 m/s
				1 in./sec. = 2.54 cm/s
				1 ft./sec. = 0.00508 m/s
				1 mile/hr. = 0.44704 m/s
				1 km/hr. = 0.27777 m/s
				1 mile/hr = 1.609344 km/hr.
				1 ft./s ² = 0.3048 m/s ²

Shafting Color Code Chart

Material	Class	Random Length	
Carbon Steel	S	Painted	
Carbon Steel	L	1/2 Black 1/2 Red	
Carbon Steel	N	Gray	
Carbon Steel	D	1/2 Gray 1/2 Green	
Carbon Steel	Metric H6	Orange	
Carbon Steel	Metric H4	1/2 Blue 1/2 Orange	
Carbon Steel	Metric G6	1/2 Green 1/2 Orange	
Carbon Steel Chrome	All	1/2 Blue	
440C Stainless Steel	S	No Color	
440C Stainless Steel	L	1/2 Orange	
316 Stainless Steel	L	1/2 Cyan	
440C Stainless Steel	Metric	1/2 Yellow	
52100 Tubular	S	No Color	
52100 Tubular	L	1/2 Black 1/2 Red	
Carbon Steel Deep Case	L	1/2 Beige 1/2 Pink	
Carbon Steel Deep Case	N	1/2 Gray 1/2 Pink	
Carbon Steel Deep Case	Metric H6	Pink	

*Trademark of Thomson Industries, Inc. Thomson Industries, Inc. is registered in the U.S. Patent and Trademark Office and in other countries.

EUROPE

United Kingdom

Thomson
Phone: +44 (0) 1271 334 500
Fax: +44 (0) 1271 334 501
E-mail: sales.uk@thomsonlinear.com

Germany

Thomson
Nürtinger Straße 70
72649 Wolfschlugen
Phone: +49 (0) 7022 504 0
Fax: +49 (0) 7022 504 405
E-mail: sales.germany@thomsonlinear.com

France

Thomson
Phone: +33 (0) 243 50 03 30
Fax: +33 (0) 243 50 03 39
E-mail: sales.france@thomsonlinear.com

Italy

Thomson
Largo Brughetti
20030 Bovisio Masciago
Phone: +39 0362 594260
Fax: +39 0362 594263
E-mail: info@thomsonlinear.it

Spain

Thomson
Rbla Badal, 29-31 7th, 1st
08014 Barcelona
Phone: +34 (0) 9329 80278
Fax: + 34 (0) 9329 80278
E-mail: sales.esm@thomsonlinear.com

Sweden

Thomson
Estridsväg 10
29109 Kristianstad
Phone: +46 (0) 44 24 67 00
Fax: +46 (0) 44 24 40 85
E-mail: sales.scandinavia@thomsonlinear.com

SOUTH AMERICA

Thomson
Sao Paulo, SP Brazil
Phone: +55 11 3879-6600
Fax: +55 11 3879 6656
E-mail: sales.brazil@thomsonlinear.com

USA, CANADA and MEXICO

Thomson
203A West Rock Road
Radford, VA 24141, USA
Phone: 1-540-633-3549
Fax: 1-540-633-0294
E-mail: thomson@thomsonlinear.com
Literature: literature.thomsonlinear.com

ASIA

Asia Pacific

Thomson
750, Oasis, Chai Chee Road,
#03-20, Technopark @ Chai Chee,
Singapore 469000
E-mail: sales.apac@thomsonlinear.com

China

Thomson
Rm 2205, Scitech Tower
22 Jianguomen Wai Street
Beijing 100004
Phone: +86 400 6661 802
Fax: +86 10 6515 0263
E-mail: sales.china@thomsonlinear.com

India

Thomson
1001, Sigma Building
Hiranandani Business Park
Powai, Mumbai – 400076
Phone: +91 22 422 70 300
Fax: +91 22 422 70 338
E-mail: sales.india@thomsonlinear.com

Japan

Thomson
Minami-Kaneden 2-12-23, Suita
Osaka 564-0044 Japan
Phone: +81-6-6386-8001
Fax: +81-6-6386-5022
E-mail: csinfo_dicgj@danaher.co.jp

Korea

Thomson
F12 Ilsong Bldg, 157-37
Samsung-dong, Kangnam-gu,
Seoul, Korea (135-090)
Phone: +82 2 6917 5049
Fax: +82 2 6917 5007
E-mail: sales.korea@thomsonlinear.com