

RF-Probes

Plug Connector, Miniature Switch
and PCB Contacting

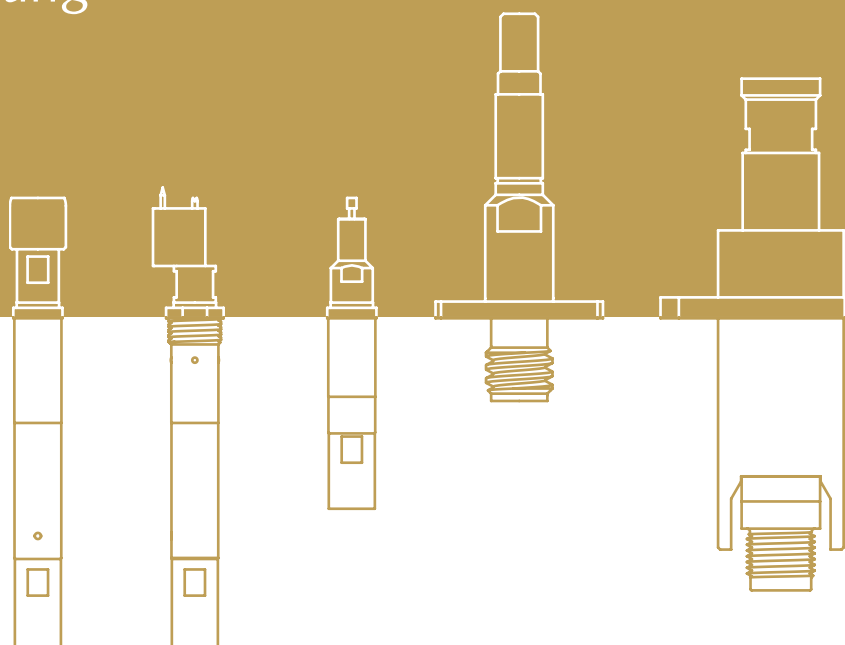

Competent in your field



Telecommunications



Information Electronics



Consumer Electronics



Automotive

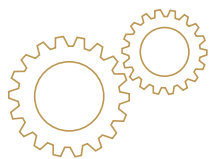

Engineering

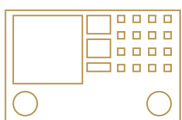

Tests and measurements



Aviation and space technology



INGUN RF test probes are used by our customers in various industries, and enable a precise, accurately repeatable test of RF performance to guarantee product quality and customer satisfaction.

As the leading company in testing, INGUN has the largest range of RF test probes worldwide. There is no doubt a RF test probe for your application too. If not, contact us for your customised contacting solution in famous INGUN quality – Made in Germany.

You will find more information about INGUN, RF test probes, and applications on pages 4 to 24.

INGUN RF Test Probes

Quality – Made in Germany

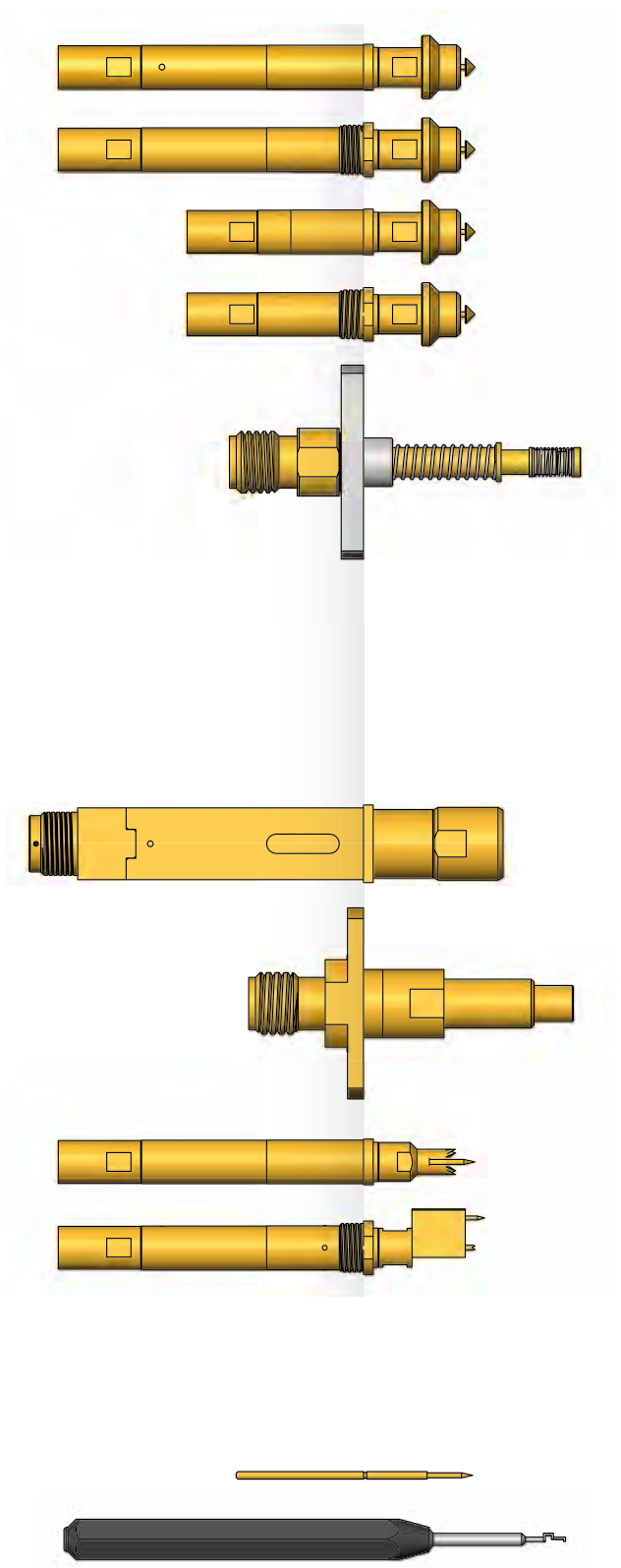

Plug connector
contacting

MMBX / MMCX / MMPX /
MBX / MCX

SMB / SMC

SMP / SMP-L / SSMP /
SMP-MAX / P-SMP / SMPX

SMA / PC3.5 / QMA

Analogue

BMA / BNC / 1.0/2.3

N / FME / 7/16

U.FL / W.FL / W.FL2 /
X.FL/ MM5829

Reverse SMA / TNC

IEC / F (75 Ω)

FAKRA / GT13 / GT16

Digital

HSD / USB Mini /
MX-series / USB-series /
RJ-series / HDMI /TAE

Miniature switch
contacting

MM8430 / MM8130 /
MM8030
MS-156 / MS-180 /
Pico II, PN 1551372-1

PCB contacting

PCB test point

PCB test point lateral

Coaxial dipole probe

Accessories

Receptacles (KS) / Cable
plug assembly / Tools /
Inner conductor

INGUN – Quality through Precision



A Family Business with Persuasive Know-how

The family business, located in Constance at the Lake of Constance, has produced and sold test probes and test fixtures all over the world since 1971, and in that time developed into the number 1 company in testing technology.

INGUN products are manufactured exclusively at the German site under the slogan **MADE IN GERMANY**, and delivered worldwide from there. With their high precision and established know-how, INGUN would like to continue to shape the future together with you.

Your competent partner since 1971

The Path to Success



1971	1976	1979	1995	2005	2007	2015
<ul style="list-style-type: none"> – “INGenieur UNION” (INGUN) – in English engineer union – founded in Konstanz by Werner H. Heilmann as a trading company for electronic components – Wolfgang Karl joins the company – 7 employees 	<ul style="list-style-type: none"> – INGUN launches their first radio frequency probe in May 1976 	<ul style="list-style-type: none"> – Introduction of the first vacuum test fixture manufactured in Germany at the Productronica trade fair in Munich 	<ul style="list-style-type: none"> – Fully automatic assembly of test probes – Certification in accordance with DIN EN ISO 9001 – 108 employees 	<ul style="list-style-type: none"> – Introduction of counterfeit protection for spring-loaded test probes – Now represented worldwide in 28 countries – 145 employees 	<ul style="list-style-type: none"> – Wolfgang Karl is appointed to board of directors – His son, Armin Karl, takes over management 	<ul style="list-style-type: none"> – 44 years of INGUN – Represented worldwide on every continent – 47 agencies – 9 subsidiaries – 350 employees

worldwide in contact



Your Reliable Partner Worldwide

INGUN co-operates with over 45 agencies worldwide and is represented all over the world with their own subsidiaries. Many of their current agencies have worked together with the test equipment specialist since the company was founded.

Your Local Contact Partner

Only those who understand their customers can offer the best products and services. The INGUN group can be reached via one of their many subsidiaries and agencies worldwide – one of which is guaranteed to be near you.

Find your local INGUN contact person today at: www.ingun.com/kontakt



Solutions for your application



INGUN offers a suitable test solution for each industry and application. This includes plug connectors, RF switches or layouts on the PCB.

Plug connectors are used in various ways to connect RF components, such as cable or PC board modules. In the automotive industry, for example, FAKRA or HSD plug connectors are used to transmit audio and video signals. U.FL connectors are used in, among others, radio modules.

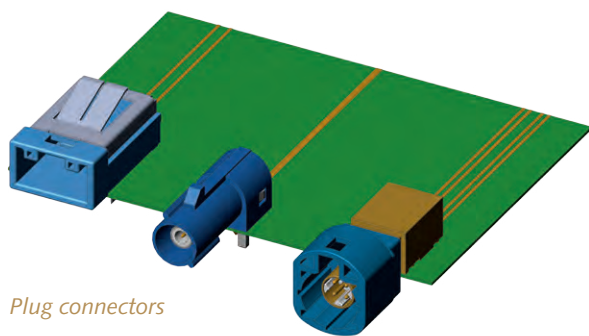

Plug connectors

RF switches are used to test RF signals supplied by either chip antenna or PCB antenna.

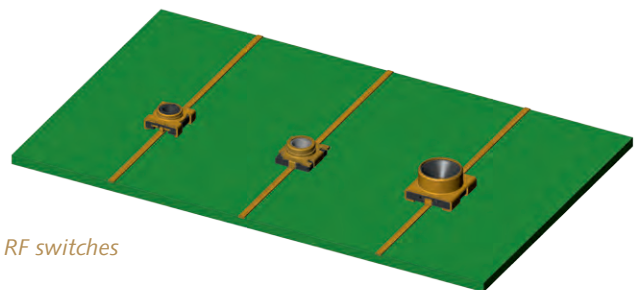

RF switches

PCB test points are structured so that they can be contacted by RF signals directly on the PCB. Depending on the nature of the PCB and application, these are carried out differently.



PCB test points

Solutions for your application

From test point to measurement system: INGUN has the compatible, optimally aligned test solution. Additionally, INGUN offers either the complete RF test fixture with RF test probes, interfaces, shielding chamber and completing cabling or as modular solutions.

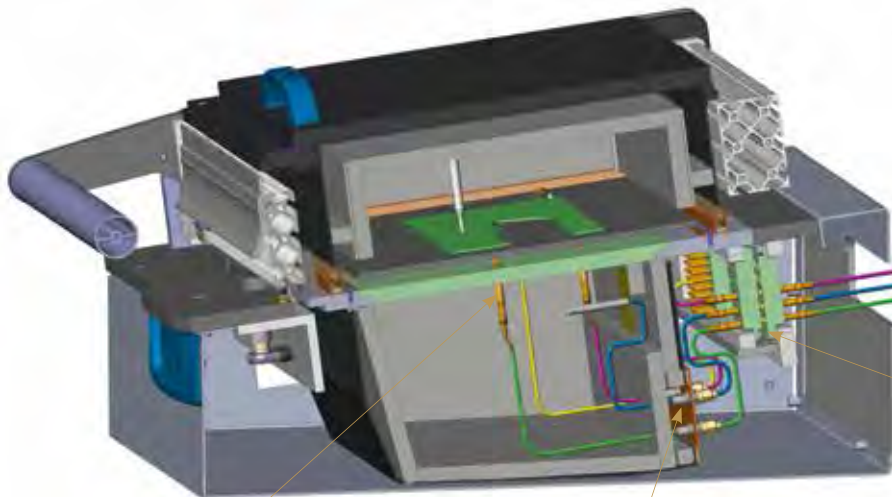

↑ connection to the measurement device



RF test fixtures and accessories: shielding chamber, interfaces, and much more, can be found in the current test fixture catalogue



For further information about RF test probes for plug connector, RF switches, PCB layouts, please see the overview on page 8/9

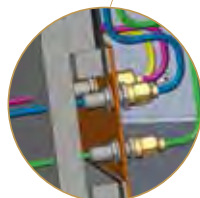

For further information about RF cables and plug connectors, please see page 196



Request our test fixture catalogue or go to our homepage www.ingun.com

Plug connector and miniature switch contacting

Plug connectors and miniature switches are used in various products and applications, such as communication electronics and consumer electronics. Other plug connectors, however, are used for the transmission of signals in the automotive industry.

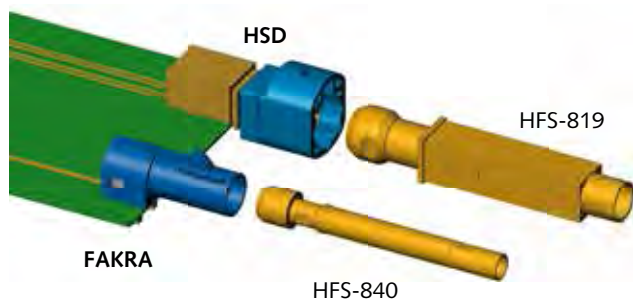

Example of automotive plug connectors

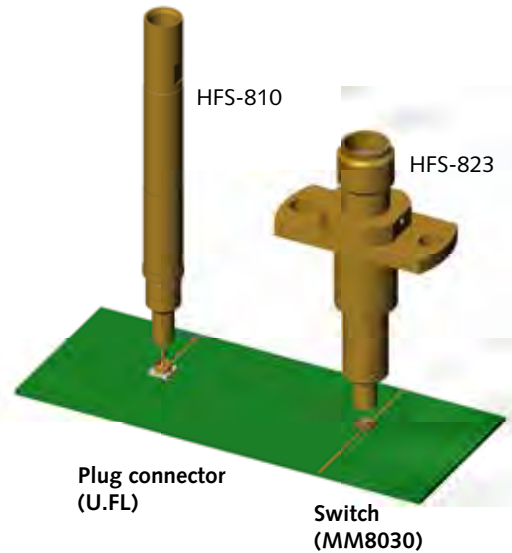

Example of plug connectors from communication and consumer electronics

RF test probes from INGUN are available for the following plug connectors and miniature switches:



PCB contacting

To test the quality of PCBs with high frequency signals, various test points are used. For this purpose, INGUN offers a variety of test solutions, which are optimally designed based on the test point layout. To correctly align the test probe to the test point, probes are mounted in a position which ensures they do not rotate (except for PCB coax closed).

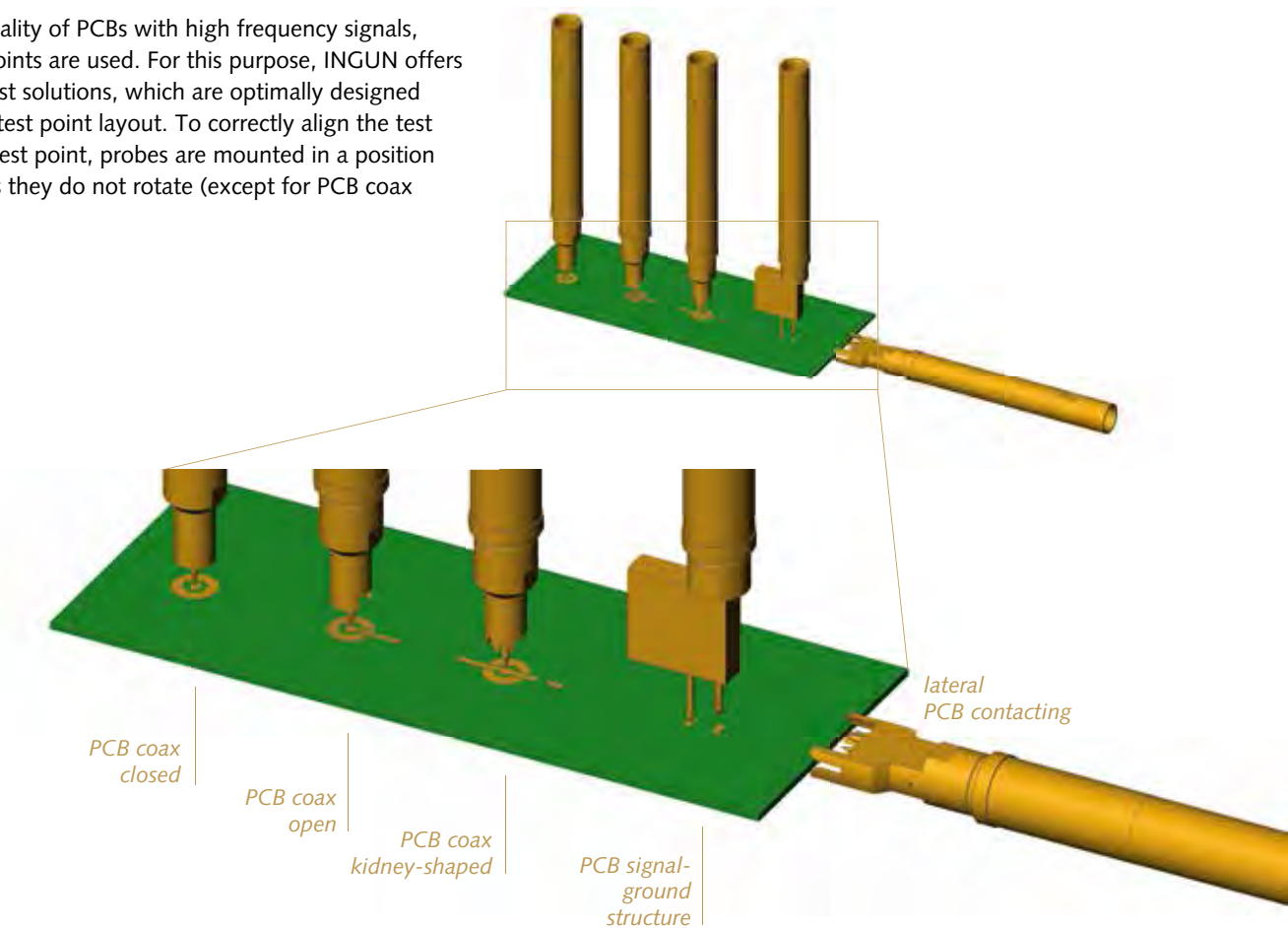

RF test probes from INGUN are available for the following PCB test points:

- PCB: PCB Layout with different levels
- PCB coax closed: PCB Layout with closed Ground/Ring and Signal Guiding to inner side (Multilayer)
- PCB coax open: PCB Layout with open Ground Ring and Signal Guiding to outer side
- PCB coax kidney: PCB Layout with kidney-shaped Ground/Ring and through Signal Guiding to outer side
- PCB side: lateral PCB contacting

Can't see your test solution?

Then speak to us! INGUN are happy to develop and produce your tailored RF test probe.

Version and application advice

For optimum fulfilment of the test requirements, various versions of RF test probes are available. Selection criteria include the test point to be contacted, frequency and/or data rate, installation area (space available), as well as ambient conditions.



E.g. U.FL

Coaxial test points

Rotation-symmetrical RF test probes are used with coaxial test points (E.g., SMA, U.FL, miniature switches) and the contact tip is optimally designed based on the connector.

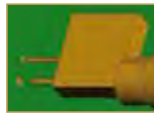

E.g. PCB signal-ground structure

Position orientated test points

To ensure contacting of position orientated test points (E.g., PCB signal-ground), non-rotating RF test probes are used.

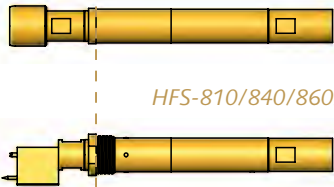
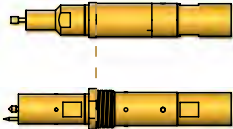
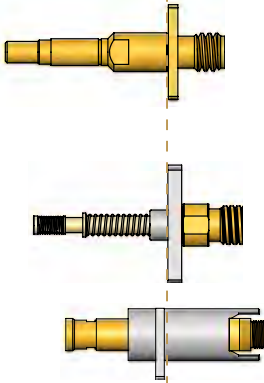
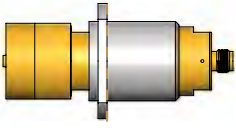
Standard HFS	 <p><i>HFS-810/840/860/865</i></p>	<p>There are standard RF probes for coaxial and position-orientated test points in various frequency domains. The RF probes are either pressed into or screwed into the receptacle. With position-oriented test points, the RF probe is aligned accordingly. To balance out the mounting tolerances on/ for coaxial test points, receptacles with fixed or free-moving mount are available. The connection is carried out by means of a MCX plug connector (with series HFS-865 using MMPX™).</p>
Short HFS	 <p><i>HFS-410/440</i></p>	<p>Short RF probes are designed for applications, which, due to limited available space, do not allow standard RF probes to be used.</p>
Flange HFS	 <p><i>HFS-822</i> <i>HFS-856</i> <i>HFS-819</i></p>	<p>RF test probes with fixed flanges are designed to enable a contacting process without cable movement. Thus, optimal signal transmission is ensured.</p> <p>RF test probes with flange and free moving (floating) contact tips enable optimal alignment to the test point and ensure a very good, repeatable measurement quality. Mounting tolerances are balanced out and consequently, side forces as a result of misalignment in the contacting process are avoided.</p>
Diverse HFS	 <p><i>HFS-864</i></p>	<p>In addition to the classic RF probes, INGUN offers more test probes for dipole measurement (Kelvin measurement), PIM stable power transmission, as well as the following probes: DPS-215, DPS-465, HFS-010, HFS-110, HFS-409, HFS-864.</p>

Assembly and Connection

Assembly

Depending on the customer application, the RF probes can be pressed into or screwed into the receptacle.

For position orientated test points (E.g., PCB ground-signal-ground) RF probes are aligned in the receptacle accordingly and are held in position by crimping points.

* With the screw-in version HFS-...4M, the RF probe is screwed in fully and then turned anti-clockwise to the required position.

Furthermore, there are various alignments for the receptacle with floating mount to compensate for the mounting tolerances (possible misalignment in the contacting process). For a comprehensive overview of the receptacles available, please see page 192.

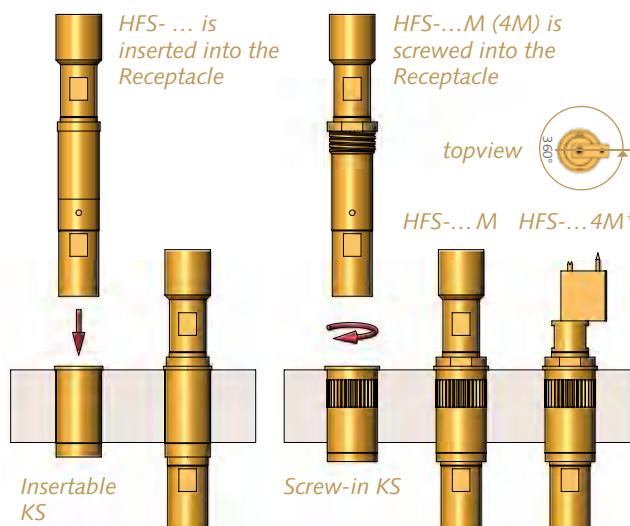

Connection

The various RF series have different connections for pre-wired RF cables.

Quick coupling connector MCX is used as the interface for the HFS-410/440/810/840/860 series. A MMPX™ input interface is used in the HFS-865 series (12 GHz). Flange HFS-822/823/852/856 are connected via a SMA connector.



For a complete overview of available RF cable plug assemblies, see page 196-199

Installation instructions

To ensure the minimum bending radius of the RF cable in several series does not exceed, care should be taken during assembly to ensure that the cable reaches "X" (see right) comfortably, with sufficient space for the cable plug assembly including specified minimum bending radius.

For applications with limited space available, cable plug assemblies with angular plugs are available, see page 196.

Furthermore, side force during the contacting process should be avoided. This could occur through possible misalignment in the contacting process, or incorrectly laid RF cables. Otherwise, this can lead to the reduction in the performance of, or even damage to, the RF test probes and cables.

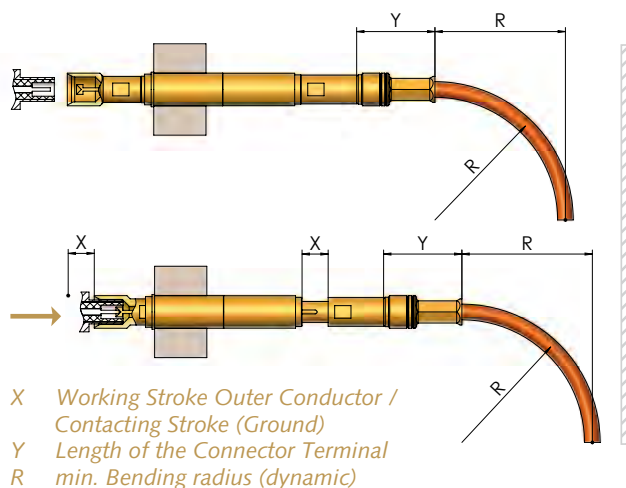

X Working Stroke Outer Conductor / Contacting Stroke (Ground)
 Y Length of the Connector Terminal
 R min. Bending radius (dynamic)

Choosing the right test probe

From test point to RF test probe:

The prerequisite to performing/conducting precise and accurately-repeatable RF measurements is a correctly selected RF test probe as well as its correct assembly and connection. The following steps should help with RF test probe selection:



- | | | | | |
|---|---|--|--|---|
| <p>1 What kind of unit is to be tested?</p> <ul style="list-style-type: none"> – Plug connector – Miniature switch – PCB test point | <p>2 What is the name of the connector, or what is the geometry of the test point?</p> | <p>3 What is the max. frequency to be transmitted at which return loss?</p> | <p>4 Which choice of RF probe version does the installation area (available space) allow for?</p> | <p>5 How should the probe be mounted and connected (RF cable)?</p> |
|---|---|--|--|---|

Selection example

The RF signal should be tested for quality assurance of a LTE-radio module:









- 1** Type of unit to be tested: plug connector
- 2** Plug connector: U.FL
- 3** Frequency: 1800 MHz
- 4** RF probe version: standard probe HFS-810 or flange probe HFS-856 is recommended.
- 5** Connection option – 2 versions
 1. HFS-810 with MCX cable connection, assembly in receptacle with fixed or free moving mounting (to balance out the misalignment through mounting tolerances)
 2. HFS-856 with SMA cable connection, assembly via flange.



Contacting of LTE module (U.FL) with HFS-856

Icons are included in the page headings for easy navigation within the index and product pages.

Icons

-  Signal Conductor Plug: Connector with Signal Conductor/Inner Conductor designed as Connector/Pin
-  Signal Conductor Jack: Connector with Signal Conductor/Inner conductor designed as Jack
-  PCB: PCB Layout with different levels
-  PCB coax closed: PCB Layout with closed Ground/Ring and Signal Guiding to inner side (Multilayer)
-  PCB coax open: PCB Layout with open Ground Ring and Signal Guiding to outer side
-  PCB coax kidney: PCB Layout with kidney-shaped Ground/Ring and through Signal Guiding to outer side
-  PCB side: lateral PCB contacting
-  Switch: Contacting of Switch Connectors
-  Digital: Connector for digital/differential Signal Transfer

Choosing the right test probe

	Standard RF test probes pressed in / screwed in				Short RF test probes pressed in / screwed in		Flange RF test probes Fixed flange / floating flange						RF test probes Diverse	page	
RF test probe series	HFS-810	HFS-840	HFS-860	HFS-865	HFS-410	HFS-440	HFS-819	HFS-821	HFS-822	HFS-823	HFS-852	HFS-856	s. bottom		
Frequency or Gbit/s	2 GHz	4 GHz	6 GHz	12 GHz	2 GHz	4 GHz	Gbit/s	Gbit/s	6 GHz	8 GHz	6 GHz	12 GHz	s. page		
Cable movement by contact	yes	yes	yes	yes	yes	yes	yes	yes	no	no	yes	yes	s. page		
Image															
1.0/2.3	x	x			x	x							59		
7/16													HFS-864	85	
BMA	x	x			x	x								55	
BNC	x	x			x	x								57	
F													HFS-409	108	
FAKRA	x	x			x	x								111	
FME	x	x			x	x								83	
GT13	x	x			x	x								115	
GT16	x	x			x	x								117	
HDMI													PS-HDMI	136	
HSD							x							124	
IEC													HFS-409	107	
MBX	x	x			x	x			x					34	
MCX	x	x	x		x	x								38	
MM5829									x					98	
MMBX	x	x		x	x	x								28	
MMCX	x	x			x	x								31	
MMPX				x										33	
MX-series								x						130	
N	x		x		x									81	
PC3.5				x										69	
P-SMP									x					59	
QMA			x											70	
RJ-series													PS-RJ	137	
R-SMA			x											101	
R-TNC	x	x			x	x								102	
SMA	x	x	x	x	x	x								63	
SMB	x	x			x	x								43	
SMC	x	x			x	x								47	
SMP	x	x			x	x						x		52	
SMP-L									x					55	
SMP-MAX									x					57	
SMPX				x										60	
SSMP			x											56	
TAE													PS-TAE	136	
U.FL	x	x	x		x	x			x		x	x		90	
USB-series								x					PS-USB	129	
W.-FL			x									x		96	
W.-FL2			x									x		96	
X.FL			x									x		96	
RF switches	MM8030, MM8130, MM8430									x		x		142	
	MS-156, MS-180									x		x		147	
	Pico II, PN 1551372-1									x				151	
	Coaxial dipole probes / Kelvin measurement												HFS-010, HFS-110, DPS-215, DPS-465	187	
PCB	PCB coax closed / (75 ohm)				x	x								HFS-858	156
	PCB coax kidney-shaped				x	x	x								161
	PCB coax open / (75 ohm)				x	x	x							HFS-858	158
	PCB-GSG / PCB-GGSGG				x	x								HFS-836	170
	PCB-SG / PCB-SG-compensation				x	x								HFS-837	164
	PCB lateral test point				x	x									183

All RF test probes available from INGUN are listed in the table above. The optimal test solution can be selected based on the

test point (plug connection, RF switch or PCB layout) and the frequency required.

Product numbers

The logical composition of the INGUN parts numbers allows easy identification and recognition of radio frequency test probes. The individual numbers define series, material, tip

style, diameter and spring force. Within the respective pages of the catalogue various possible combinations, special designations, and type versions are described.

INGUN RF product number

HFS - 810 3 08 180 A 53 42 BX M

1
 2
 3
 4
 5
 6
 7
 8
 9
 10

Type of product 1
HFS Radio frequency test probe

Series 2

DPS-215	Dipole probe	----
DPS-465	Dipole probe	----
HFS-010	Dipole probe	----
HFS-110	Dipole probe	----
HFS-409	F / IEC	1,5 GHz
HFS-410	Short version	2 GHz
HFS-440	Short version	4 GHz
HFS-810	Standard	2 GHz
HFS-819	Digital	Gbit/s
HFS-821	Digital	Gbit/s
HFS-822	Flange	6 GHz
HFS-823	Flange	6 GHz
HFS-836	Flange	4 GHz
HFS-837	Flange	12 GHz
HFS-840	Standard	4 GHz
HFS-852	Flange	6 GHz
HFS-856	Flange	6 GHz
HFS-858	PCB 75Ω	1 GHz
HFS-860	Standard	6 GHz
HFS-864	7/16	7,5 GHz
HFS-865	Standard	12 GHz

Material of inner conductor contacting tip 3

2 steel **3** beryllium copper

Inner conductor tip style 4

01	spear point	08	conical tip
03	inverse cone	13	30° tip with bullet-nose
04	crown	53	inverse cone: special length
05	bullet-nosed	55	bullet-nosed: special length
06	serrated	58	cone: special length
07	90° tri-hedral or pyramid		

Inner conductor tip diameter (1/100 mm) 5

Example:
180 1,8 mm (tip-ø inner conductor)

Surface 6

A INGUN hard gold

Spring Force (dN) 7

Sum of spring force of inner and outer conductor
 Example:
53 1.3 N inner conductor + 4,0 N outer conductor

Outer plunger 8

02 flat
06 serrated
14 self-cleaning 4-point crown
29 ground tips
40 lamellas
42 centering: inner side of plug connector
43 centering: outer side of plug connector

Special indexes 9

Type 10

– press-in version
M screw-in version
4M screw-in version adjustable

High measuring accuracy and long lifetime

Quality through precision – we have developed, manufactured, and distributed products for the telecommunication, consumer electronics, and the automotive industry, among others, under this motto since 1971. As the leading company in test equipment manufacturing, we have the largest range of radio frequency test probes and test fixtures worldwide. INGUN RF products are an important contribution to the overall quality assurance of the products for our global customers.

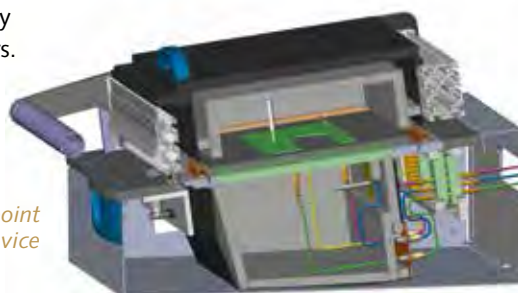

RF fixture, from test point to measurement device

Quality through Precision – Made in Germany

A high measurement accuracy, repeatability, and long service lives are vital for RF products. To ensure this essential consistent product quality of the innovative RF test probes INGUN operates its own RF laboratory. Here production conditions can be optimally regulated, and electrical as well as mechanical tests can be performed. The recording of S-parameter, VSWR graphs, and Smith chart are part of the standard measurement. Furthermore, the RF performance of the RF test probes under defined angular and coaxial misalignment can be determined.

Whether standard RF probes or customer-specific solutions, the RF test probes from INGUN are developed and manufactured in accordance with the highest quality standards.



RF endurance test stand PHF4 performs a combination of mechanical and electrical life cycle tests

Decades of experience, innovative know-how, and close contact to our customers are our strengths. Try us out for your optimal test solution!



Quality "Made in Germany".
INGUN has been DIN EN ISO 9001 certified since 1995

Integrated Technologies

High impedance tip – RF test probes with integrated filter

Measurement by RF test probes normally takes place in series with the device under test (DUT). The test solution is therefore a part of the signal path. To ensure minimal return loss the test solution must have the same impedance as the device under test (e.g. 50 Ω). If the measurement, however, takes place in a closed part of the signal path, it must be guaranteed that this path is not affected by the test solution. In the case of measurement with a standard test solution, 50% of the energy would be lost. This is due to the test solution being parallel to the test object (DUT). To avoid this, INGUN has developed a specialised test probe which enables a high-resistance signal pick-up, and therefore does not affect the signal path.

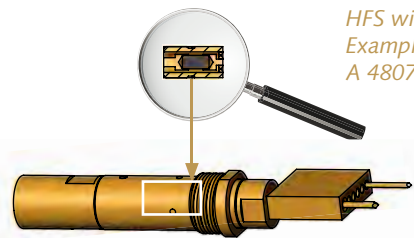

A three-port measurement is performed to specify this measurement solution, whereby port 1 and port 2 are connected to the test object (DUT) and port 3 is connected to the RF test probe.

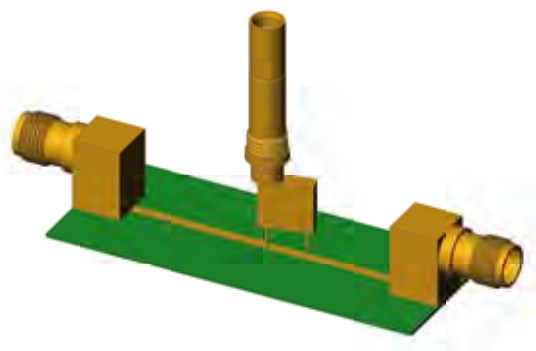

Example of test set-up with three-port measurement

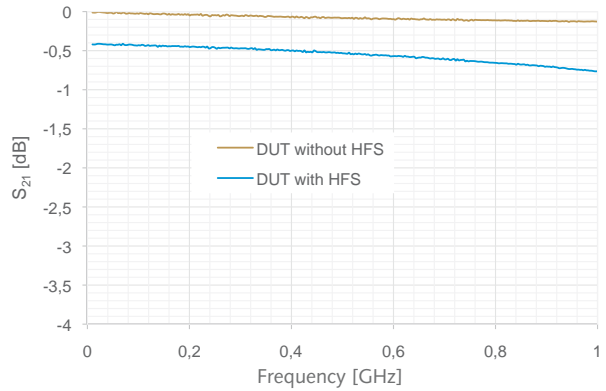

Insertion loss of the DUT with and without contacting of the RF test probe

As the measurement shows, the DUT is only slightly affected by the test probe. The amount of power lost is at least 20 dB less. This is equal to a voltage reduction of 1/10, for example, for a measurement with an oscilloscope. Parasitic coupling is significantly reduced using a short ground connection. This test solution is particularly suitable for automated test on DUTs with an oscilloscope.

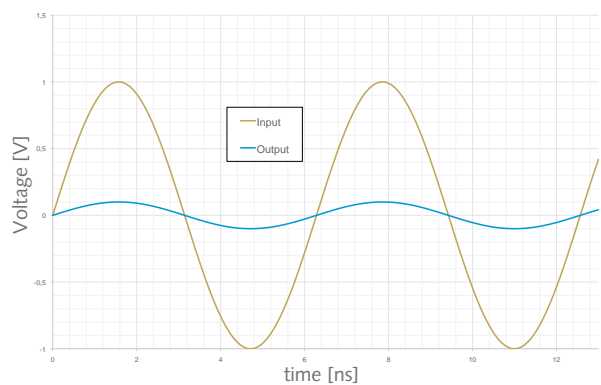

1/10 scaling factor of RF test probe is clear as shown in time domain

More information about RF test probes with integrated filter s. page 169

RF test probes with narrow band matching network

There are applications where the RF test points have complex resistances (Z) made up of a real part (R) and an imaginary part (X) ($Z = R + jX$). In order to be able to connect the test system, a transformation of the complex resistance should occur to achieve an impedance of 50Ω without an imaginary part. An example should clarify this:

To measure a signal at the feeding point of a GPS antenna, a RF probe picks up the signal and feeds it into the test system. The complex resistance would be $Z_{ant} = 30 \Omega + j90 \Omega$ for the centre frequency of the frequency range 1.575 GHz to 1.6 GHz.

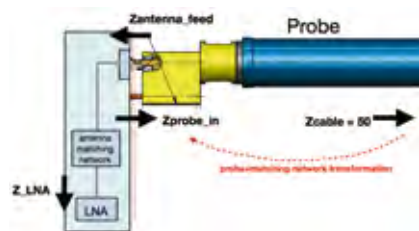

Example for the use of a RF test probe with narrow band matching network

If the electrical characteristics of the test solution in use are also known, the signal can be electrically influenced in this way to enable the transformation to an impedance of 50Ω . This, however, is only valid for a very narrow frequency range.

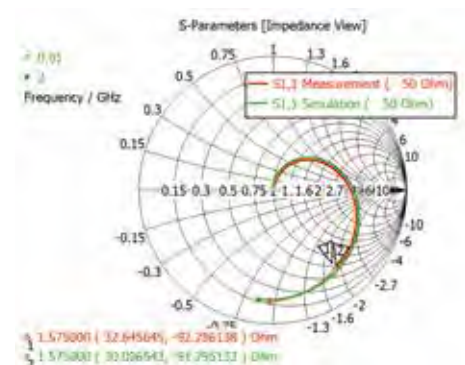

Comparison of simulation and measurement: The transformation shown in the Smith chart

Can't see your test solution? Then speak to us! INGUN are happy to develop and produce your tailored RF test probe.

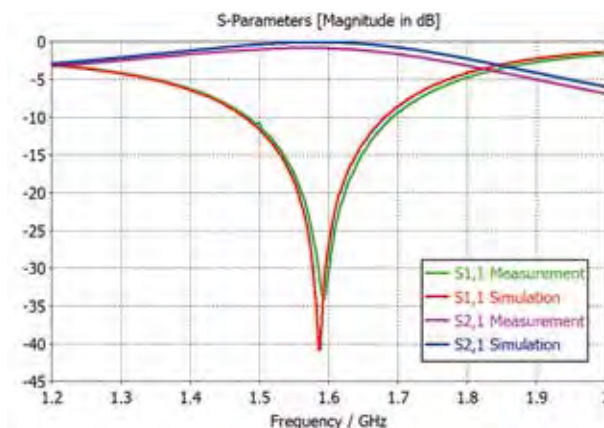

Comparison of simulation and measurement: a very good return loss determines the center frequency of the application for a narrow band frequency range

INGUN is able to perform this transformation within the test solution. In this case, a RF test probe which integrates a narrow band matching network is used.



RF test probe with narrow band matching network

In the same way, test probes which influence the characteristics of transmission as desired can also be developed. The test probe can, for example, have filter characteristics. A wide-band transformation can also be performed.

RF products from INGUN

An introduction to RF technology

For an INGUN radio frequency test probe to be able to achieve optimal performance the radio frequency properties must be precisely determined. In order to understand why we at IGUN think that some measurements are a vital part in the development and quality management process, we invite you to explore the world of the theory behind the product for a few minutes.

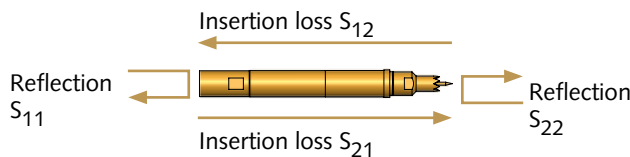

Scatter parameter determination

The properties of an electrical network can be determined at low frequencies by determining the current and voltage ratios. As the frequency rises, it is increasingly difficult to be able to measure U and I directly. Instead, the wave characteristics on the ports of the DUT are determined in order to determine those properties. These are the so-called scattering parameters, or S-parameters for short.

Radio frequency test probes or cable assemblies form the input and output interface for each port in the electrical network. This is known as a two-port network. For example, a cable plug assembly is connected to the input interface with a power P₁ (incident wave), in this way a part is again directly reflected in the feeding system. This reflection cannot be prevented, but minimised. The level of attenuation of the reflected wave in comparison to the incident wave is called return loss and corresponds to the S-parameter S₁₁ (input) or S₂₂ (output).

A further part of the wave feeds in the network and is attenuated as it travels through the system. The S-Parameter S₂₁ or S₁₂ describes this transmission process. The parameter is also known as insertion loss.

To fully describe the properties of a 2-port RF network, there are a total of four S-parameters, each of which are determined according to magnitude and phase: S_{xy,value} and S_{xy,phase} (with x,y = 1...2). The reciprocity principle, however, applies to linear passive components in good proximity.

$$S_{21} \approx S_{12} \quad (1)$$

This facilitates the precise measurement of radio frequency probe characteristics. It can be assumed that it makes no difference whether the signals should be picked up or fed in. For both cases it is irrelevant, due to reciprocity, which direction the signal transmitted in because the attenuation levels are the same in both cases.

Light wave analogy

To get a better idea of what is meant by reflection and transmission parameters, one can compare the behaviour of the incident and reflected electromagnetic waves with light waves hitting a lens. A part of the energy from the incident waves is reflected when the light hits, while the remaining part is transmitted. The S-parameter can be derived from the ratios of the reflected part to the approaching waves and the transmitted part compared with the incident waves.

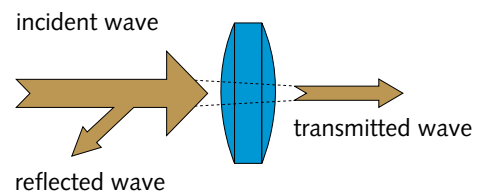

Notations

Standing wave ratio (SWR)

Manufacturers sometimes provide the progression of the standing wave ratio of a frequency rather than the return loss. This can be calculated from the return loss and is a further notation.

The following applies:

$$VSWR = \frac{1 + 10^{-\frac{RL'}{20}}}{1 - 10^{-\frac{RL'}{20}}} \quad (2)$$

Analogue can be calculated using the standing wave ratio of the return loss:

$$RL' = -20 \text{ dB} \cdot \log\left(\frac{VSWR - 1}{VSWR + 1}\right) \quad (3)$$

Reflection behaviour

Alongside the notations described, the signal reflection characteristics can also be shown in a so-called Smith chart. The progression of the return loss according to magnitude and phase is also shown. This is particularly suitable for determining correction values and being able to provide complex impedance and admittance values (e.g. equivalent circuit diagrams, simulations, etc.)

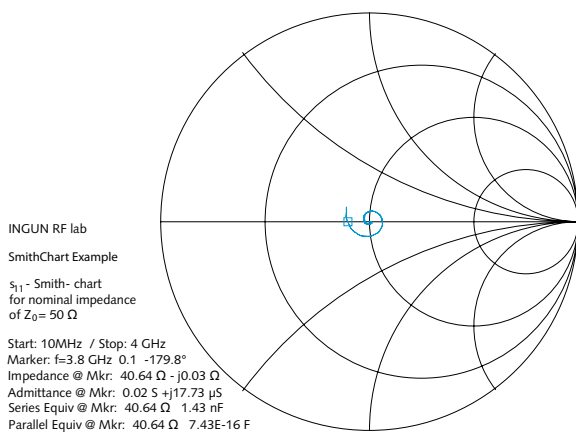

Time domain reflectometry (TDR)

TDR stands for time domain reflectometry. For this type of measurement an ultra-short impulse is generated using a suitable measurement device, such as a sampling scope with TDR module. As the impulse runs through the device under test (DUT), impedance variations or other reflection disturbances develop, and these can be shown and evaluated.

The respective points in time in the following formula are used to calculate the impedance from the reflection coefficient.

$$Z_L = Z_0 \cdot \frac{(1 + \rho)}{(1 - \rho)}$$

The impedance progression is determined by the transmission of the resulting impedance over time. The electrical length of the DUT can be taken directly from this notation, however its mechanical length cannot, because the propagation velocity of the impulse depends on the materials used. The measurement resolution achieved correlates to the duration of the impulse. If short impulses are used, very small measurement objects can also be measured relatively accurately.

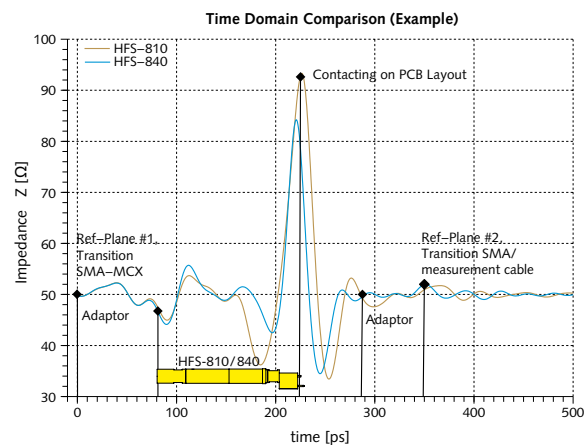

Impedance progression of sample of a RF test probe TDR measurement

Eye mask

The eye diagram is generated using multiple overlap from individual bits of a transmitted signal. To achieve higher accuracy, the sample used should be as long as possible. Information such as jitter, and loss of the transmission channel can be read from the eye diagram. The so-called eye mask also specifies the minimum requirement of the transmission medium.

RF products from INGUN

Specification of coaxial (analogue) RF test probes

Test solutions for the measurement of analogue signals are normally specified in the frequency domain using so-called S-parameters, which are measured with a Vector Network Analyser (VNA). INGUN uses a 20 GHz 2 Port VNA. Because VNA test cables are used, which have either a PC3.5 or SMA interface (the reference plane in this case) various measurement and calibration adapters are also used to connect the test solution.

As these adapters are added after the calibration in the signal path, they inevitably influence the measurement results. For that reason, it is essential to be aware of the influence of the adapter during the specification of the test solution. To be able to correct the magnitude and the phase shift, the so-called port expansion feature is used. INGUN also uses its self-developed SOLT calibration kits in combination with the de-embedding function.

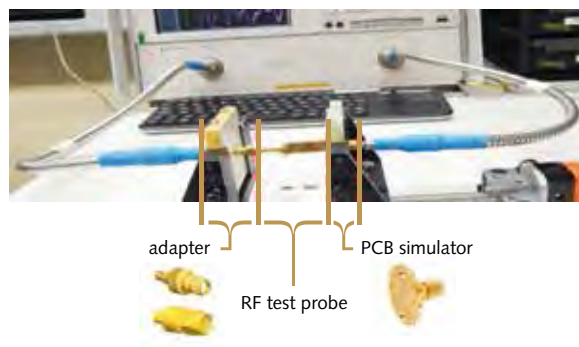

The chart of the individual S-parameters can be derived easily from the s2p files (Touchstone format) generated.

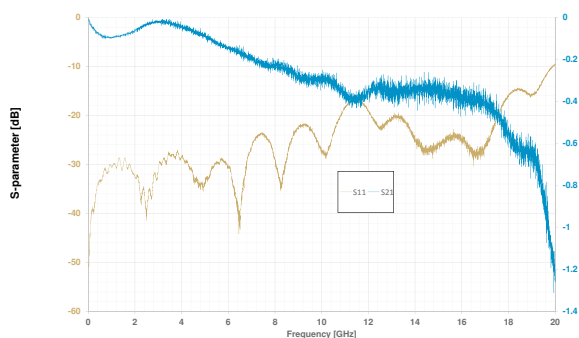

Return and insertion loss of a RF test probe

Specification of test probes for digital data transmission

INGUN has a wide range of digital RF test probes. Classic, analogue test solutions can be fully described using the S-parameter. By contrast, there are other criteria for digital test solutions. These are dependent on the transmission standards used. For example, to be able to specify the test solution for the transmission of USB 3.0 signals, the test specification demands, among other things, the specification of differential impedance and insertion loss, jitter, crosstalk, and many more.

However, one of the most important criterion during specification is signal integrity of the entire signal path, which is shown in a so-called eye diagram. Matching the resulting eye diagram with the eye mask, provided by the transmission standard, reveals whether the transmission path meets the minimum requirements with regard to its electrical properties.

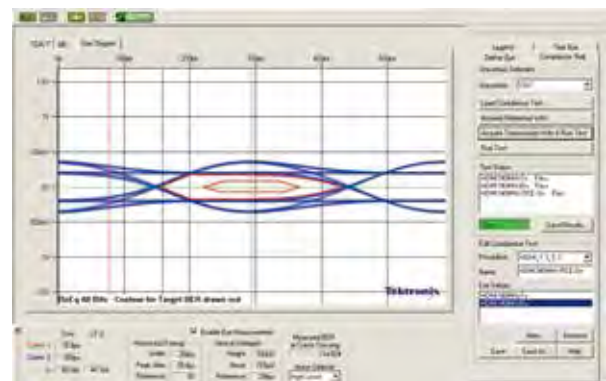

The INGUN laboratory has the capacity (the appropriate measurement equipment and software) to perform specification of digital test probes. Using time domain analyses, measurements to determine the differential impedance can also be performed.

S-parameter of RF Test Probes

If a RF test probe is part of a signal path that needs to be characterised, its characteristics of transmission must be known precisely. The electrical properties of the test probe required with its reference plane 1 on its input interface, and reference plane 2 on the contact point in the working stroke are described using the S-parameter.

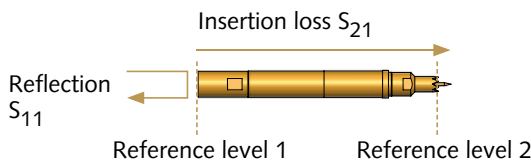

INGUN provides accompanying charts, also as digital s2p files in Touchstone format. These refer to the typical characteristics of transmission of the corresponding RF test probe. Please contact us if you require support with the characterisation of your signal path.



Connection for MMMPX™-plug

INGUN test set-up

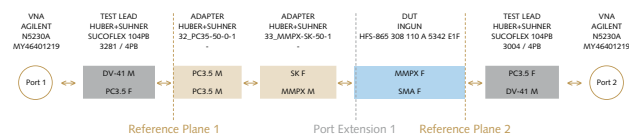

Schematic illustration of measurement set-up

Further S-parameter charts or s2p files in Touchstone format available upon request.

Typical characteristics of transmission HFS-865 308 110 A 5342 E1F

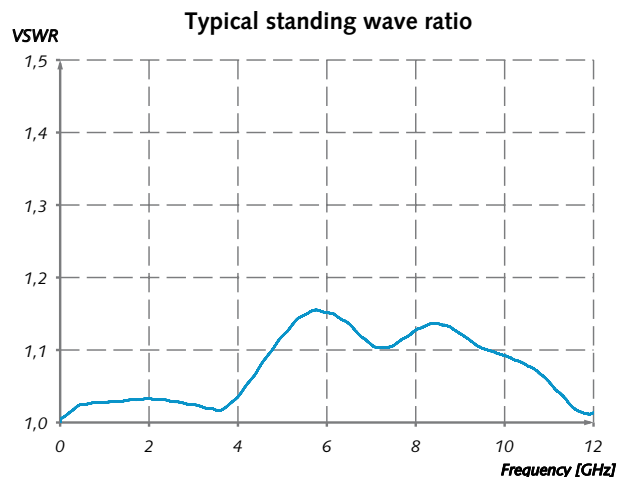
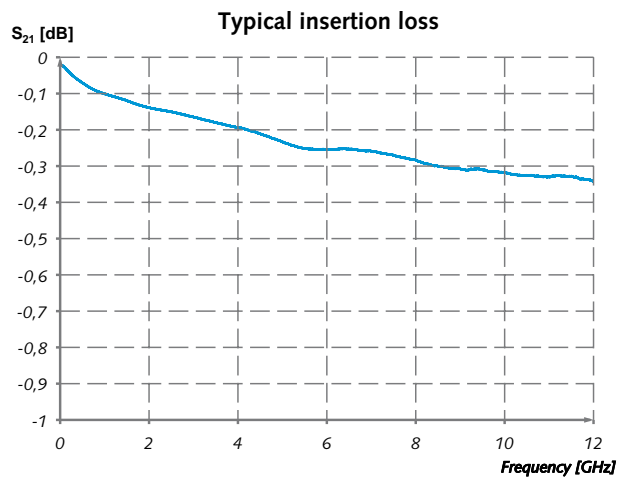
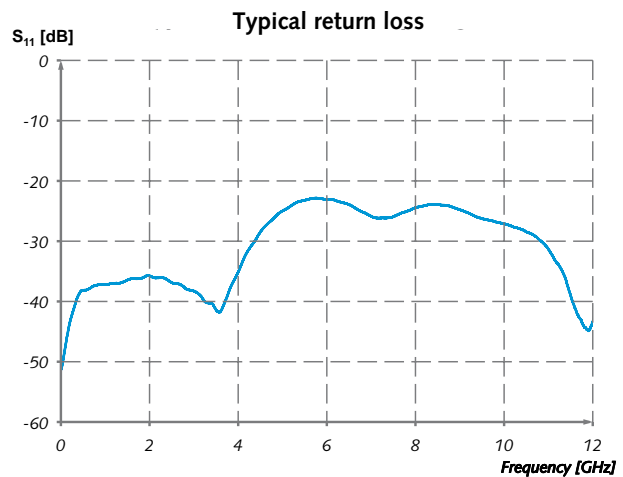

In-line attenuator for RF test probes

In-line attenuator

To artificially improve the return loss, so-called in-line attenuators can be used. These reduce the amplitude of the measurement signal. However, this factor is often less important than the fact that a reflected signal runs through an attenuator twice and therefore the return loss is theoretically improved twice as much as the attenuation values.

INGUN offers standard 50 Ω attenuators with 3 dB and 2 Watt load capacity, as well as optional MCX or SMA connection interfaces. Further attenuation values available upon request.



For more information and ordering numbers, see page 199.

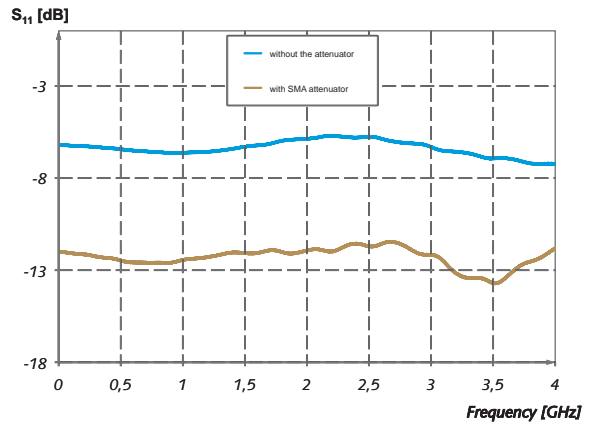

Measurement example: improvement of return loss at c. 6 dB when using a 3 dB in-line attenuator

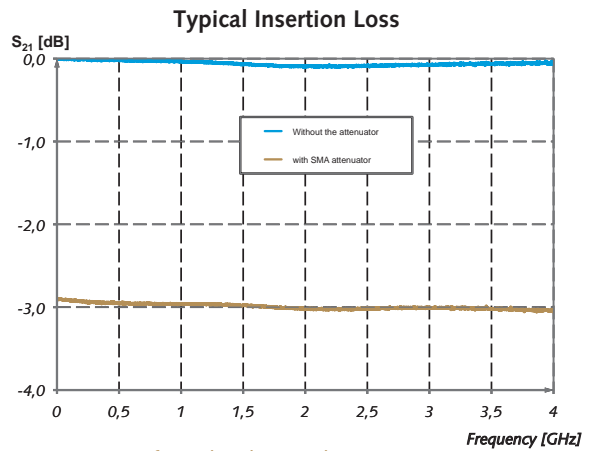

Attenuation of amplitude at 3 dB

HFS test set / PCB simulator

It is often difficult to characterise the entire signal path, including test probes, when RF test probes which are designed to contact PCBs are used. The PCB used must not be part of the measurement and should, in this case, be substituted. Therefore, INGUN has developed a RF test set especially for simulating the test point on the PCB. The set consists of two SMA adapters, two grounding plates and a connecting sleeve for the one time "back-to-back" measurement.

The set enables:

- precise measurement by accounting for the calibration of the test probe, and omitting this from the measurement.
- a quick and easy error detection, in case this is required.



General information

Structure of the INGUN RF-Probes

Base Materials

The choice of the base materials is dependent on the demands put on each individual component.

BeCu (Beryllium-Copper) provides a good combination and compromise between brass and steel: The high percentage of copper makes it an ideal electrical conductor and the small percentage of Beryllium allows the base material to be hardened (up to 435 HV). This then ensures good durability and optimizes the aggressiveness of the plunger tip.

Steel is used for practically all aggressive tip-styles. It provides a high level of hardness and sharpness of the points and the flanks. This ensures good durability and reliable contacting.

Brass is sometimes used for passive tip-styles and for machined barrels. The high percentage of copper makes it an ideal electrical conductor. Brass, however, is too soft for aggressive tip-styles.

New-Silver (NiAg) and Bronze are mainly used for Receptacles and the Barrels of the Test Probes. These materials have a high tensile strength, which is ideal for the long-term life of Test Probes. Furthermore, these materials provide a good elasticity of the crimps on the Receptacles.

Spring Steel of the highest possible quality is used for the manufacturing of the springs. For high and low temperature ranges, certain high-alloyed spring steels (i.e. stainless steel) are used.

Plating Material

INGUN hard-gold is used.

Hard-gold: Special gold-plating developed specifically for RF Probes with very good chemical durability. Hardness 150 – 200 HV. Especially good for tarnish and corrosion protection.

In the case of all plating materials the very low specific resistance values guarantee the best contacting reliability.

EG Environmental Legislations

Numerous European Environmental Legislations have the aim to ensure a high level of protection of human health and the environment. For this reason, the business decisions and actions of INGUN Prüfmittelbau GmbH are always regarded in the interest of these legislations.

For the presently most important European Environmental Legislations, INGUN has prepared official statements, which are always up to date and available on our homepage www.ingun.com/company

INGUN Environment Compliance Statement	REACH EU ordinance 1907/2006	RoHS EU directive 2002/95/EC	ACPEIP "China-RoHS"
DMF EU directive 2009/251/EC	PFOS EU directive 2006/122/EC	UL- certification UL 94	Conflict Minerals Dodd-Frank Act
radioactively contaminated stainless steel	PAK ZEK 01.2-08		

Applied Radio Frequency Technology



The radio frequency probes from INGUN are used especially when radio frequency signals must be measured.

Contacting of MMBX Connectors

Series MMBX

Connection Dimensions

Signal Conductor Plug

Signal Conductor Jack

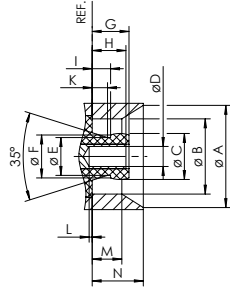
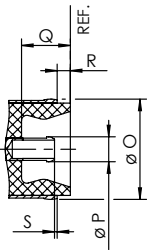

Example of manufacturer Huber+Suhner:
MMBX Signal Conductor Jack

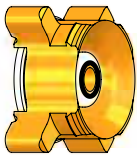

	Signal Conductor Plug/Jack	
	min.	max.
A	5.00 / .197	5.00 / .197
B	3.68 / .145	3.71 / .146
C	2.25 / .089	2.30 / .091
D	0.98 / .039	1.01 / .040
E	1.85 / .073	1.85 / .073
F	2.10 / .083	2.10 / .083
G	-	1.80 / .071
H	1.55 / .061	1.75 / .069
I	0.90 / .035	-
K	0.75 / .030	0.75 / .030
L	0 / 0	-
M	1.45 / .057	-
N	2.50 / .098	2.50 / .098
O	3.70 / .146	3.70 / .146
P	0.95 / .037	0.95 / .037
Q	1.85 / .073	1.85 / .073
R	0.50 / .020	0.50 / .020
S	0.10 / .004	0.10 / .004

Contacting of MMCX Connectors

Series MMCX

Connection Dimensions

Signal Conductor Plug

Signal Conductor Jack

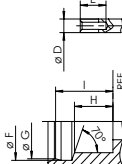
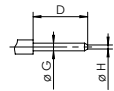
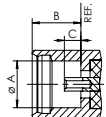
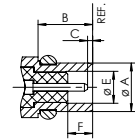

Example of manufacturer Huber+Suhner:
MMCX Signal Conductor Jack



	Signal Conductor Plug		Signal Conductor Jack	
	min.	max.	min.	max.
A	-	2.40 / .094	2.41 / .095	-
B	2.70 / .106	-	-	2.65 / .104
C	0.00 / .000	0.25 / .010	0.90 / .035	1.20 / .047
D	1.23 / .048	-	0.70 / .028 nom.	
E	1.58 / .062	1.62 / .064	1.40 / .055	-
F	1.23 / .048	-	3.00 / .118	3.04 / .120
G*	0.38 / .015	0.42 / .017	2.88 / .113	2.92 / .115
H	-	0.20 / .008	1.57 / .062	1.63 / .064

*	Jack			
G	2.88 / .113	2.90 / .114	2.92 / .115	
I	2.34 / .092	2.30 / .091	2.26 / .089	

Remarks: I is related to G

Contacting of MMPX Connectors

Series MMPX

Connection Dimensions

Signal Conductor Jack

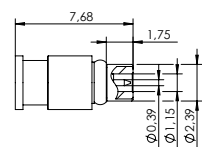

Example of manufacturer Huber+Suhner:
MMPX Conductor Jack



All specifications are subject to change without prior notification

Contents

MMBX

Signal Conductor Jack

2 GHz 28

HFS-810, HFS-810 M
HFS-410, HFS-410 M

4 GHz 29

HFS-840, HFS-840 M
HFS-440, HFS-440 M

12 GHz 30

HFS-865

MMCX

Signal Conductor Jack

2 GHz 31

HFS-810, HFS-810 M
HFS-410, HFS-410 M

4 GHz 32

HFS-840, HFS-840 M
HFS-440, HFS-440 M

MMPX

Signal Conductor Jack

12 GHz 33

HFS-865

MBX s. Page 34 - 37

MCX s. Page 38 - 40

Receptacles (KS) 192 - 194

Spacer of Receptacles (DS) 195

Cable plug assembly (SE) 196 - 199

Tools 200 - 201

Inner Conductor/ Signal Conductor 202 - 204

MMBX /
MMCX / MMPX
MBX / MCX

SMB / SMC

SMP (X/MAX) /
SMP-L 55SMP /
P-5MP

SMA / PC3.5
QMA

BMA / BNC
1.0/2.3

N / FME /
7/16

U.FL / W.FL /
W.FL2 / X.FL /
MM5829

Reverse
SMA / TNC

IEC /
F (75 Ω)

FAKRA /
GT13 / GT16

Digital

Switch
connector
contacting

PCB
test point

PCB test
point side

Coaxial
dipole probe

Accessories

Contacting of MBX Connectors

Contents

MBX

Signal Conductor Plug

6 GHz 34
HFS-822

Signal Conductor Jack

2 GHz 35
HFS-810, HFS-810 M
HFS-410, HFS-410 M

4 GHz 36
HFS-840, HFS-840 M
HFS-440, HFS-440 M

6 GHz 37
HFS-822

Series MBX

Connection Dimensions

Signal Conductor Plug

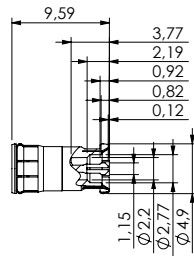

Signal Conductor Jack

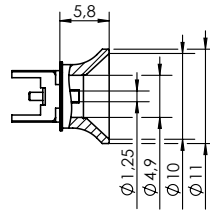

Example of manufacturer Huber+Suhner:

MBX Signal Conductor Plug



MBX Signal Conductor Jack



MCX

Signal Conductor Jack

2 GHz 38
HFS-810, HFS-810 M
HFS-410, HFS-410 M

4 GHz 39
HFS-840, HFS-840 M
HFS-440, HFS-440 M

6 GHz 40
HFS-860, HFS-860 M

Contacting of MCX Connectors

Series MCX

Connection Dimensions

Signal Conductor Plug

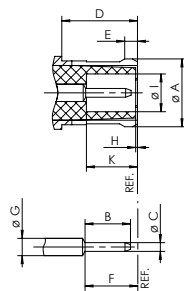

Signal Conductor Jack

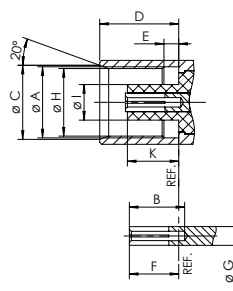

	Signal Conductor Plug		Signal Conductor Jack	
	min.	max.	min.	max.
A	3.72 / .146*	3.80 / .150*	3.60 / .142	3.70 / .146
B	2.49 / .098	2.59 / .102	2.80 / .110	-
C	0.48 / .019	0.53 / .021	3.75 / .148	3.85 / .152
D	4.15 / .163	-	4.00 / .157	4.12 / .162
E	0.70 / .028	0.75 / .030	0.75 / .030	0.85 / .033
F	2.80 / .110	3.20 / .126	2.30 / .091	2.80 / .110
G	0.95 / .037 nom.		0.95 / .037 nom.	
H	-	0.30 / .012	3.42 / .135	3.48 / .137
I	2.00 / .079	2.07 / .081	1.80 / .071	1.98 / .078
K	2.80 / .110	3.20 / .126	2.60 / .102	2.80 / .110

Example of manufacturer Huber+Suhner:

MCX Signal Conductor Jack

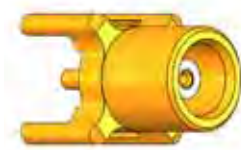

Receptacles (KS) 192 - 194

Spacer of Receptacles (DS) 195

Cable plug assembly (SE) 196 - 199

Tools 200 - 201

Inner Conductor/ Signal Conductor 202 - 204

MMBX / MMCX / MMPX / MBX / MCX Connectors

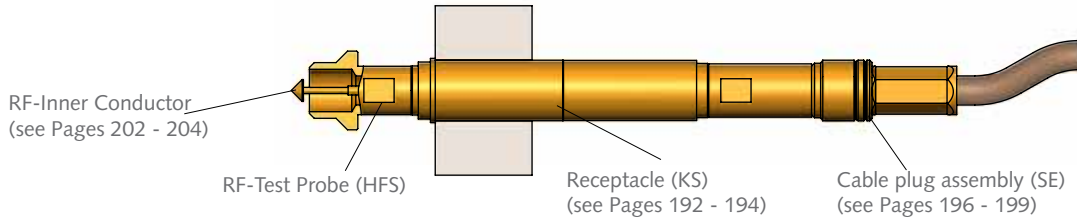

Contacting Example MMBX:

Contacting of MMBX Signal Conductor Jack
HFS-810 308 180 A 5342 BX

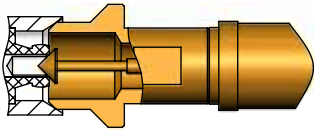

Customizing Example:

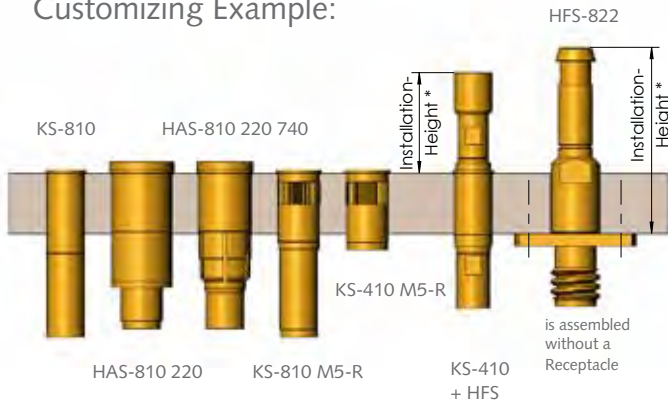

Electrical Data

HFS-810 / 810 M HFS-840 / 840 M

HFS-410 / 410 M HFS-440 / 440 M

HFS-822 HFS-860 / 860 M HFS-865

Frequency Range with HFS-810/410: up to 2 GHz

Frequency Range with HFS-840/440: up to 4 GHz

Frequency Range with HFS-860: up to 6 GHz

Frequency Range with HFS-865: up to 12 GHz

Current Rating Outer Conductor: 8–10 A

Current Rating Inner Conductor: 2–3 A

R_i typical Inner Conductor: ≤ 10 mΩ

Impedance Test Probe: 50 Ω

Impedance Cable: 50 Ω

Operating Temperature Range

–40 up to +80° C

Installation Height in Receptacle	KS-810 (F) KS-410 (F) KS-810 M5-(R/F) KS-410 M5-(R/F)	HAS-810 220 (F) HAS-810 220 740 (F)	without KS	
Variant		* Installation Height HFS in KS		
MMBX Signal Conductor Jack	...BX / ... BX M	11.9 mm	13.0 mm	---
	... BXF / ... BXF M	10.3 mm	11.4 mm	---
MMCX Signal Conductor Jack	... Z / ... Z M	11.1 mm	12.2 mm	---
MMPX Signal Conductor Jack	... PF	10.9 mm	12.0 mm	---
MBX Signal Conductor Plug	... MBXF	---	---	28.5 mm
MBX Signal Conductor Jack	... MBX / ... MBX M	12.4 mm	13.15 mm	---
MCX Signal Conductor Jack	... X / ... X M	12.9 mm	14.0 mm	---
	(HFS-860) ... X / ... XM	11.9 mm	13.0 mm	---
	...X4/...X4M	11.8 mm	12.9 mm	---

Note:

Further details of receptacles with and without flange connection (F) see pages 192 - 194.

MMBX Signal Conductor Jack

up to 2 GHz
(50 Ω)

HFS-810 / HFS-810 M
HFS-410 / HFS-410 M

Series:

Available Tip Styles:

Ordering Description:

HFS-810 ...

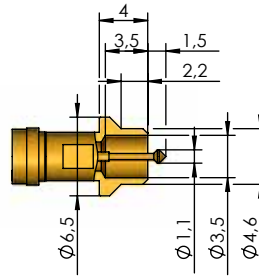
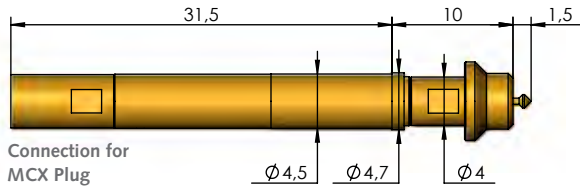

HFS-810 308 110 A **xx** 42 BX
HFS-810 308 110 A **xx** 42 BX M
HFS-410 308 110 A **xx** 42 BX
HFS-410 308 110 A **xx** 42 BX M

Note:
Centering range: ± 0.5 mm

HFS-810 ... M (*)

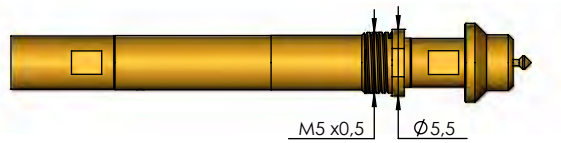

HFS-410 ...

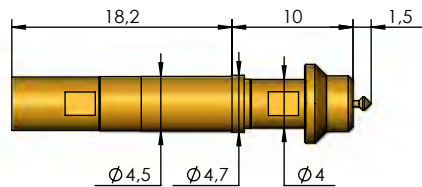

HFS-410 ... M (*)

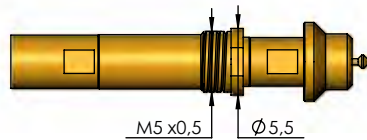

Spring force rating

The spring-loaded Inner and Outer Conductors are available with different spring forces. The ordering description is derived by adding up the individual values.

	HFS-810 HFS-810 M				HFS-410 HFS-410 M
Spring Force of Inner Conductor (N)	1.3	2.0	1.3	2.0	1.0
Spring Force of Outer Conductor (N)	4.0	6.0	8.0	8.0	4.0
Character for ordering	53	80	93	99	50

Note: (*)

For usage in the case of vibration, shaking, snapping or assembly upside down.

Mechanical Data

HFS-810 and HFS-810 M

	Outer Cond.	Inner Cond.
Working Stroke:	4.0 mm	2.0 mm
Maximum Stroke:	5.0 mm	3.7 mm

Mechanical Data

HFS-410 and HFS-410 M

	Outer Cond.	Inner Cond.
Working Stroke:	2.0 mm	2.0 mm
Maximum Stroke:	3.0 mm	3.0 mm

Series:

Available Tip Styles:

Ordering Description:

HFS-840 ...

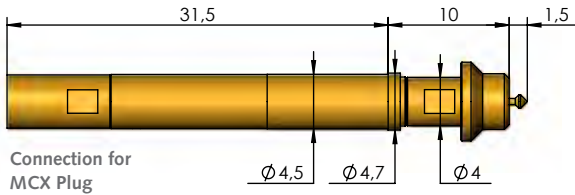

Connection for MCX Plug

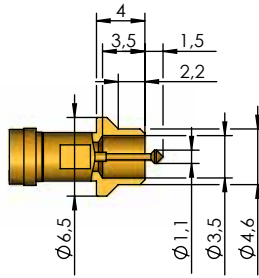

- HFS-840 308 110 A **xx** 42 BX
- HFS-840 308 110 A **xx** 42 BX M
- HFS-440 308 110 A **xx** 42 BX
- HFS-440 308 110 A **xx** 42 BX M

Note:
Centering range: ± 0.5 mm

HFS-840 ... M (*)

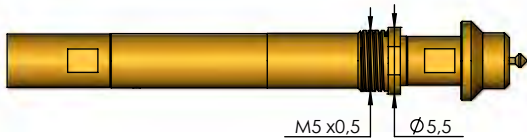

HFS-440 ...

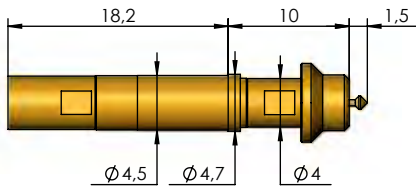

HFS-440 ... M (*)

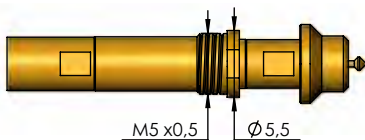

Spring force rating

The spring-loaded Inner and Outer Conductors are available with different spring forces. The ordering description is derived by adding up the individual values.

	HFS-840 HFS-840 M				HFS-440 HFS-440 M
Spring Force of Inner Conductor (N)	1.3	2.0	1.3	2.0	1.0
Spring Force of Outer Conductor (N)	4.0	6.0	8.0	8.0	4.0
Character for ordering	53	80	93	99	50

Note: (*)

For usage in the case of vibration, shaking, snapping or assembly upside down.

Mechanical Data

HFS-840 and HFS-840 M

	Outer Cond.	Inner Cond.
Working Stroke:	4.0 mm	2.0 mm
Maximum Stroke:	5.0 mm	3.7 mm

Mechanical Data

HFS-440 and HFS-440 M

	Outer Cond.	Inner Cond.
Working Stroke:	2.0 mm	2.0 mm
Maximum Stroke:	3.0 mm	3.0 mm

MMBX / MMBX
MMCK / MMBPX
MMB / MCK
SMB / SMC
SMP (X/MAX)
SMP-L 55MP / P-5MP
SMA / PC3.5
QMA
BMA / BNC
1.0/2.3
N / FME /
7/16
U.FL / W.FL /
W.FL2 / X.FL /
MM5829
Reverse
SMA / TNC
IEC /
F (75 Ω)
FAKRA /
GT13 / GT16
Digital
Switch
connector
contacting
PCB
test point
PCB test
point side
Coaxial
dipole probe
Accessories

MMBX Signal Conductor Jack

up to 12 GHz
(50 Ω)

HFS-865

Series:

Available Tip Styles:

Ordering Description:

HFS-865 ...

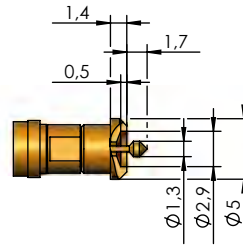
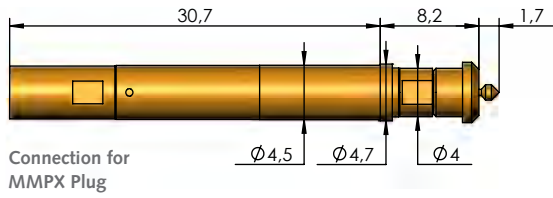

HFS-865 308 127 A **xx** 42 BXF

Note:
Centering range: ± 0.3 mm

Spring force rating

The spring-loaded Outer Conductors are available with different spring forces. The ordering description is derived by adding up the individual values.

	HFS-865		
Spring Force of Inner Conductor (N)	1.3	1.3	1.3
Spring Force of Outer Conductor (N)	4.0	6.0	8.0
Character for ordering	53	73	93

Mechanical Data

HFS-865

	Outer Cond.	Inner Cond.
Working Stroke:	4.0 mm	1.0 mm
Maximum Stroke:	5.0 mm	1.5 mm

Series:

Available Tip Styles:

Ordering Description:

HFS-810 ...

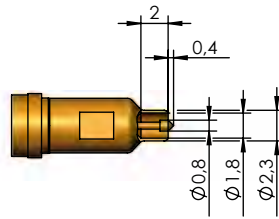
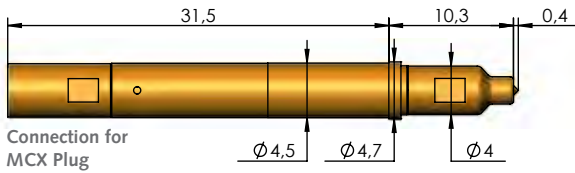

- HFS-810 358 080 A **xx** 42 Z
- HFS-810 358 080 A **xx** 42 Z M
- HFS-410 358 080 A **xx** 42 Z
- HFS-410 358 080 A **xx** 42 Z M

Note: Version with pre-centering on the inner side of the Connector Outer Contact. Centering range: ± 0.4 mm

HFS-810 ... M (*)

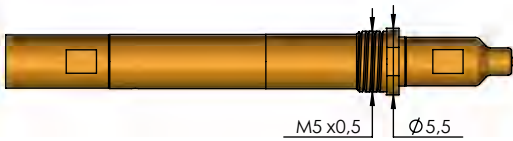

HFS-410 ...

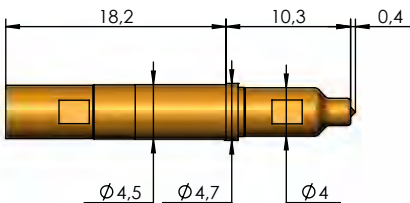

HFS-410 ... M (*)

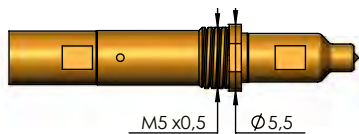

Spring force rating

The spring-loaded Inner and Outer Conductors are available with different spring forces. The ordering description is derived by adding up the individual values.

	HFS-810 HFS-810 M				HFS-410 HFS-410 M
Spring Force of Inner Conductor (N)	1.3	2.0	1.3	2.0	1.0
Spring Force of Outer Conductor (N)	4.0	6.0	8.0	8.0	4.0
Character for ordering	53	80	93	99	50

Note: (*)

For usage in the case of vibration, shaking, snapping or assembly upside down.

Mechanical Data

HFS-810 and HFS-810 M

	Outer Cond.	Inner Cond.
Working Stroke:	4.0 mm	1.2 mm
Maximum Stroke:	5.0 mm	2.9 mm

Mechanical Data

HFS-410 and HFS-410 M

	Outer Cond.	Inner Cond.
Working Stroke:	2.0 mm	1.2 mm
Maximum Stroke:	3.0 mm	2.2 mm

MMBX / MMCX / MMMPX / MCB / MCBX / SMB / SMC / SMP (X/MAX) / SMP-L / SSMP / P-SSMP / SMA / PC3.5 / QMA / BMA / BNC / 1, 0/2, 3 / N / FME / 7/16 / U.FL / W.FL / W.FL2 / X.FL / MM5829 / Reverse SMA / TNC / IEC / F (75 Ω) / FAKRA / GT13 / GT16 / Digital / Switch connector contacting / PCB test point / PCB test point side / Coaxial dipole probe / Accessories

MMCX Signal Conductor Jack

up to 4 GHz
(50 Ω)

HFS-840 / HFS-840 M
HFS-440 / HFS-440 M

Series:

Available Tip Styles:

Ordering Description:

HFS-840 ...

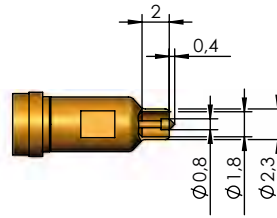
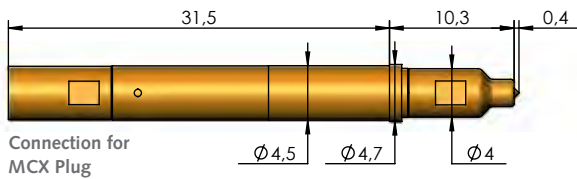

HFS-840 358 080 A **xx** 42 Z
HFS-840 358 080 A **xx** 42 Z M
HFS-440 358 080 A **xx** 42 Z
HFS-440 358 080 A **xx** 42 Z M

Note: Version with pre-centering on the inner side of the Connector Outer Contact. Centering range: ± 0.4 mm

HFS-840 ... M (*)

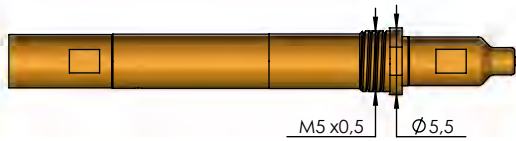

HFS-440 ...

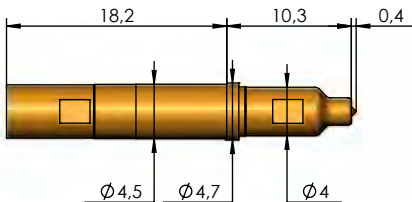

HFS-440 ... M (*)

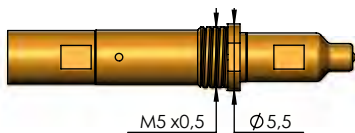

Spring force rating

The spring-loaded Inner and Outer Conductors are available with different spring forces. The ordering description is derived by adding up the individual values.

	HFS-840 HFS-840 M				HFS-440 HFS-440 M
Spring Force of Inner Conductor (N)	1.3	2.0	1.3	2.0	1.0
Spring Force of Outer Conductor (N)	4.0	6.0	8.0	8.0	4.0
Character for ordering	53	80	93	99	50

Note: (*)

For usage in the case of vibration, shaking, snapping or assembly upside down.

Mechanical Data

HFS-840 and HFS-840 M

	Outer Cond.	Inner Cond.
Working Stroke:	4.0 mm	1.2 mm
Maximum Stroke:	5.0 mm	2.9 mm

Mechanical Data

HFS-440 and HFS-440 M

	Outer Cond.	Inner Cond.
Working Stroke:	2.0 mm	1.2 mm
Maximum Stroke:	3.0 mm	2.2 mm

Series:

Available Tip Styles:

Ordering Description:

HFS-865 ...

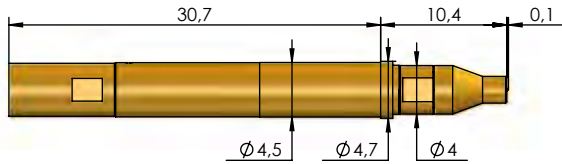

Connection for MMPX Plug

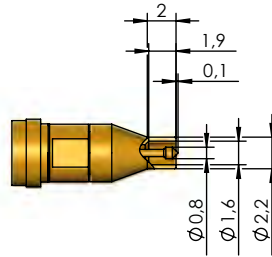

HFS-865 308 080 A **xx** 42 MMPF

Note: Version with pre-centering on the inner side of the Connector Outer Contact. Centering range: ± 0.3 mm

Spring force rating

The spring-loaded Outer Conductors are available with different spring forces. The ordering description is derived by adding up the individual values.

	HFS-865		
Spring Force of Inner Conductor (N)	1.3	1.3	1.3
Spring Force of Outer Conductor (N)	4.0	6.0	8.0
Character for ordering	53	73	93

Mechanical Data

HFS-865

	Outer Cond.	Inner Cond.
Working Stroke:	4.0 mm	1.0 mm
Maximum Stroke:	5.0 mm	1.5 mm

MMBX / MMCK / MMPX MBX / MCX
 SMB / SMC
 SMP (X/MAX) / SMP-L 5SMP / P-5SMP
 SMA / PC3.5 QMA
 BMA / BNC 1.0/2.3
 N / FME / 7/16
 U.FL / W.FL / W.FL2 / X.FL / MM5829
 Reverse SMA / TNC
 IEC / F (75 Ω)
 FAKRA / GT13 / GT16
 Digital
 Switch connector contacting
 PCB test point
 PCB test point side
 Coaxial dipole probe
 Accessories

MBX Signal Conductor Plug

up to 6 GHz
(50 Ω)

HFS-822

Series:

Available
Tip Styles:

Ordering Description:

HFS-822 ...

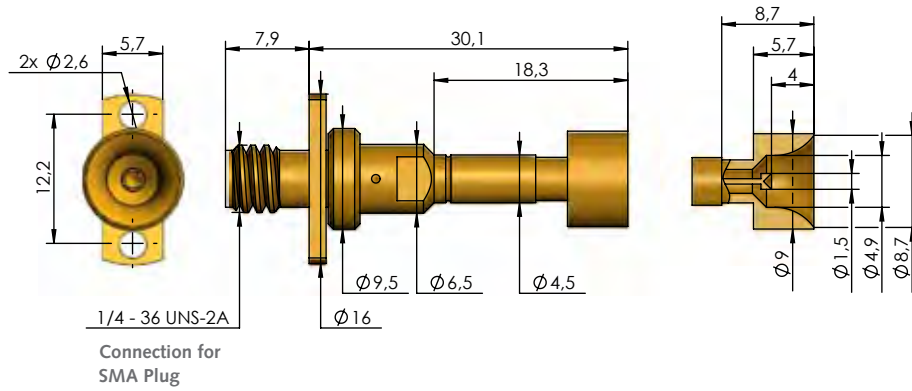

HFS-810 308 180 A **xx** 42 MBX

Note: Version with flange connection. No movement of the connection during stroke movement.
Centering range: ± 1.8 mm

Spring force rating

The spring-loaded Inner and Outer Conductors are available with different spring forces. The ordering description is derived by adding up the individual values.

Note:

The RF test probes in the HFS-822 series are positioned and fixed with two screws using a flange connection.

For usage in the case of vibration, shaking, snapping or assembly upside down.

	HFS-822
Spring Force of Inner Conductor (N)	1.0
Spring Force of Outer Conductor (N)	4.0
Character for ordering	50

Mechanical Data

HFS-822

	Outer Cond.	Inner Cond.
Working Stroke:	2.0 mm	2.0 mm
Maximum Stroke:	3.0 mm	3.0 mm

Series:

Available
Tip Styles:

Ordering Description:

HFS-810 ...

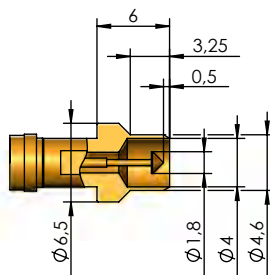
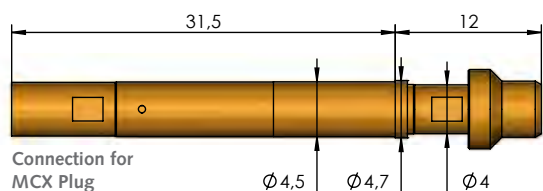

HFS-810 308 180 A **xx** 42 MBX
HFS-810 308 180 A **xx** 42 MBX M
HFS-410 308 180 A **xx** 42 MBX
HFS-410 308 180 A **xx** 42 MBX M

Note: Version with pre-centering on the inner side of the Connector Outer Contact. Centering range: ± 0.4 mm

HFS-810 ... M (*)

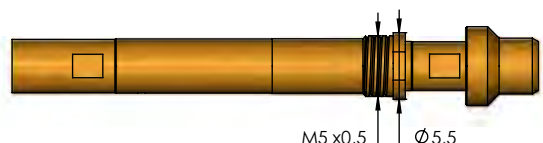

HFS-410 ...

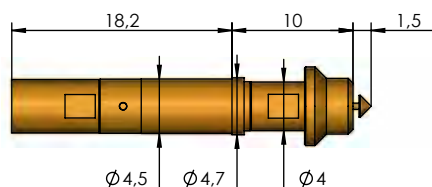

HFS-410 ... M (*)

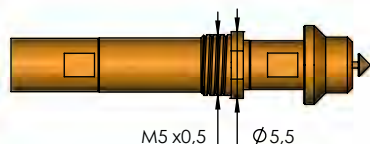

Spring force rating

The spring-loaded Inner and Outer Conductors are available with different spring forces. The ordering description is derived by adding up the individual values.

	HFS-810 HFS-810 M				HFS-410 HFS-410 M
Spring Force of Inner Conductor (N)	1.3	2.0	1.3	2.0	1.0
Spring Force of Outer Conductor (N)	4.0	6.0	8.0	8.0	4.0
Character for ordering	53	80	93	99	50

Note: (*)

For usage in the case of vibration, shaking, snapping or assembly upside down.

Mechanical Data

HFS-810 and HFS-810 M

	Outer Cond.	Inner Cond.
Working Stroke:	4.0 mm	2.0 mm
Maximum Stroke:	5.0 mm	3.7 mm

Mechanical Data

HFS-410 and HFS-410 M

	Outer Cond.	Inner Cond.
Working Stroke:	2.0 mm	2.0 mm
Maximum Stroke:	3.0 mm	3.0 mm

MBX Signal Conductor Jack

up to 4 GHz
(50 Ω)

HFS-840 / HFS-840 M
HFS-440 / HFS-440 M

Series:

Available Tip Styles:

Ordering Description:

HFS-840 ...

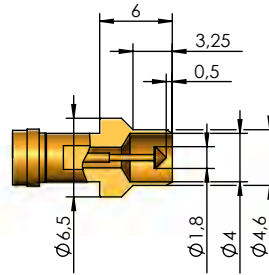
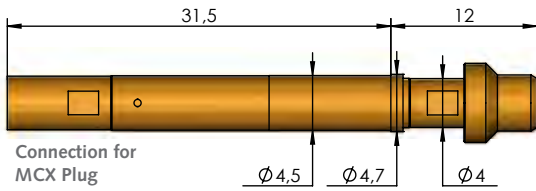

HFS-840 308 180 A **xx** 42 MBX
HFS-840 308 180 A **xx** 42 MBX M
HFS-440 308 180 A **xx** 42 MBX
HFS-440 308 180 A **xx** 42 MBX M

Note: Version with pre-centering on the inner side of the Connector Outer Contact. Centering range: ± 0.4 mm

HFS-840 ... M (*)

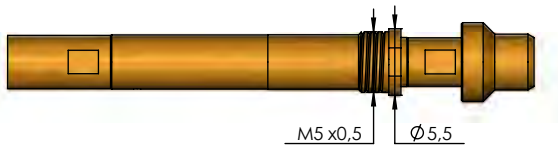

HFS-440 ...

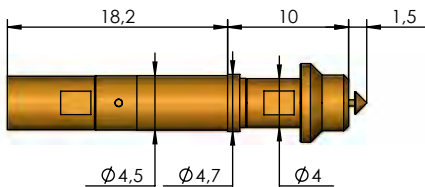

HFS-440 ... M (*)

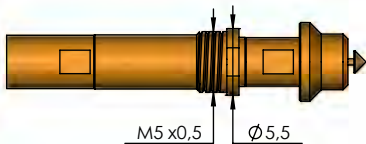

Spring force rating

The spring-loaded Inner and Outer Conductors are available with different spring forces. The ordering description is derived by adding up the individual values.

	HFS-840 HFS-840 M				HFS-440 HFS-440 M
Spring Force of Inner Conductor (N)	1.3	2.0	1.3	2.0	1.0
Spring Force of Outer Conductor (N)	4.0	6.0	8.0	8.0	4.0
Character for ordering	53	80	93	99	50

Note: (*)

For usage in the case of vibration, shaking, snapping or assembly upside down.

Mechanical Data

HFS-840 and HFS-840 M

	Outer Cond.	Inner Cond.
Working Stroke:	4.0 mm	2.0 mm
Maximum Stroke:	5.0 mm	3.7 mm

Mechanical Data

HFS-440 and HFS-440 M

	Outer Cond.	Inner Cond.
Working Stroke:	2.0 mm	2.0 mm
Maximum Stroke:	3.0 mm	3.0 mm

Series:

Available Tip Styles:

Ordering Description:

HFS-822 ...

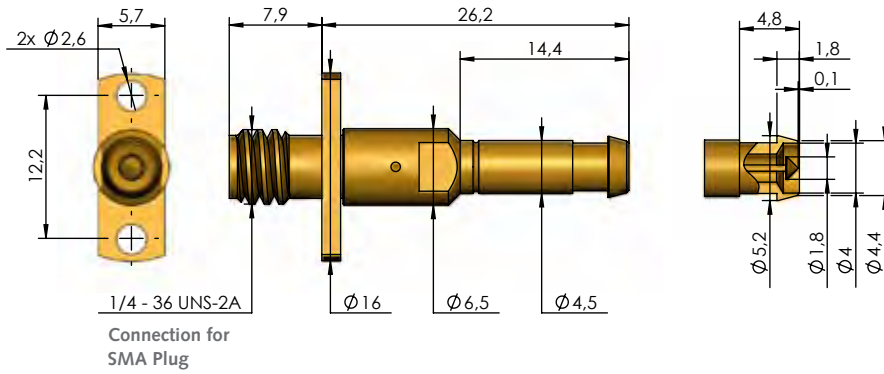

HFS-822 308 180 A **xx** 42 MBX2

Note: Version with flange connection. No movement of the connection during stroke movement.
Centering range: ± 0.4 mm

Spring force rating

The spring-loaded Inner and Outer Conductors are available with different spring forces. The ordering description is derived by adding up the individual values.

Note:

The RF test probes in the HFS-822 series are positioned and fixed with two screws using a flange connection.

For usage in the case of vibration, shaking, snapping or assembly upside down.

	HFS-822
Spring Force of Inner Conductor (N)	1.0
Spring Force of Outer Conductor (N)	4.0
Character for ordering	50

Mechanical Data

HFS-822

	Outer Cond.	Inner Cond.
Working Stroke:	2.0 mm	2.0 mm
Maximum Stroke:	3.0 mm	3.0 mm

MMBX / MMCP / MMMPX / MBX / MCBX
 SMB / SMC
 SMP (X/MAX) / SMP-L 55SMP / P-5SMP
 SMA / PC3.5 QMA
 BMA / BNC 1.0/2.3
 N / FME / 7/16
 U.FL / W.FL / W.FL2 / X.FL / MM5829
 Reverse SMA / TNC
 IEC / F (75 Ω)
 FAKRA / GT13 / GT16
 Digital
 Switch connector contacting
 PCB test point
 PCB test point side
 Coaxial dipole probe
 Accessories

MCX Signal Conductor Jack

up to 2 GHz
(50 Ω)

HFS-810 / HFS-810 M
HFS-410 / HFS-410 M

Series:

Available Tip Styles:

Ordering Description:

HFS-810 ...

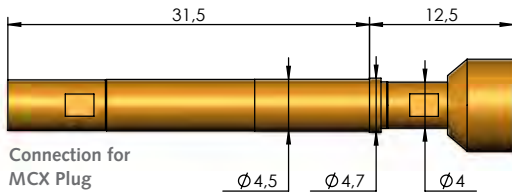

HFS-810 ... M (*)

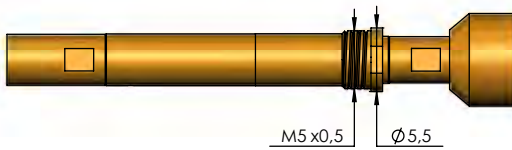

HFS-410 ...

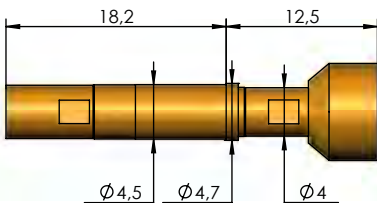

HFS-410 ... M (*)

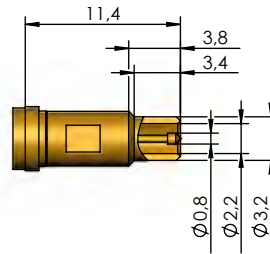
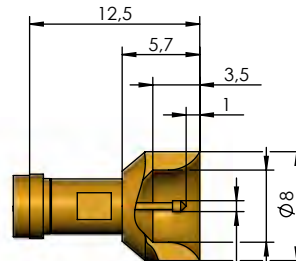
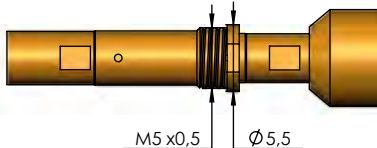

- HFS-810 308 080 A **xx** 43 X
- HFS-810 308 080 A **xx** 43 X M
- HFS-410 308 080 A **xx** 43 X
- HFS-410 308 080 A **xx** 43 X M

Note: Version with enlarged centering range. Outer plunger centers itself from the outer side on the Connector.
Centering range: ± 1.4 mm

- HFS-810 308 080 A **xx** 42 X4
- HFS-810 308 080 A **xx** 42 X4 M
- HFS-410 308 080 A **xx** 42 X4
- HFS-410 308 080 A **xx** 42 X4 M

Note: Version with pre-centering on the inner side of the Connector Outer Contact.
Centering range: ± 0.6 mm

Spring force rating

The spring-loaded Inner and Outer Conductors are available with different spring forces. The ordering description is derived by adding up the individual values.

	HFS-810 HFS-810 M				HFS-410 HFS-410 M
Spring Force of Inner Conductor (N)	1.3	2.0	1.3	2.0	1.0
Spring Force of Outer Conductor (N)	4.0	6.0	8.0	8.0	4.0
Character for ordering	53	80	93	99	50

Note: (*)
For usage in the case of vibration, shaking, snapping or assembly upside down.

Mechanical Data HFS-810 and HFS-810 M		
	Outer Cond.	Inner Cond.
Working Stroke:	4.0 mm	2.0 mm
Maximum Stroke:	5.0 mm	3.7 mm

Mechanical Data HFS-410 and HFS-410 M		
	Outer Cond.	Inner Cond.
Working Stroke:	2.0 mm	2.0 mm
Maximum Stroke:	3.0 mm	3.0 mm

Series:

Available Tip Styles:

Ordering Description:

HFS-840 ...

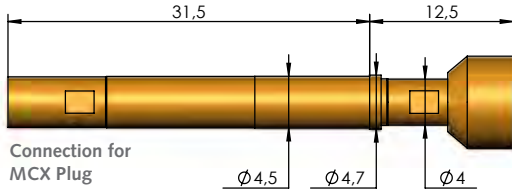

HFS-840 ... M (*)

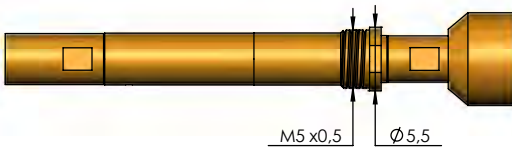

HFS-440 ...

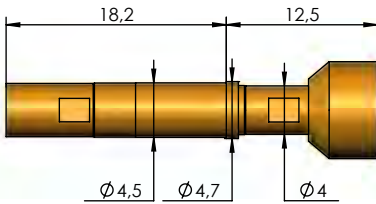

HFS-440 ... M (*)

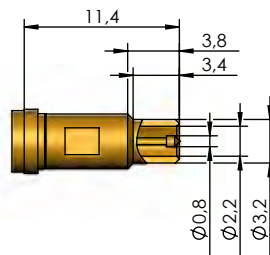
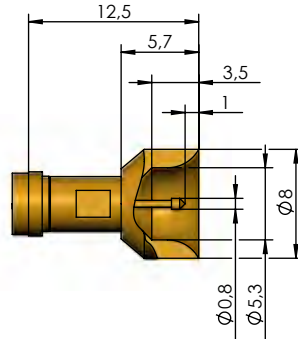
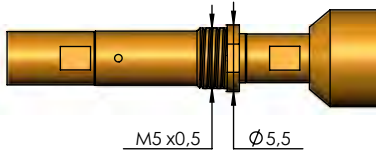

- HFS-840 308 080 A **xx** 43 X
- HFS-840 308 080 A **xx** 43 X M
- HFS-440 308 080 A **xx** 43 X
- HFS-440 308 080 A **xx** 43 X M

Note: Version with enlarged centering range. Outer plunger centers itself from the outer side on the Connector. Centering range: ± 1.4 mm

- HFS-840 308 080 A **xx** 42 X4
- HFS-840 308 080 A **xx** 42 X4 M
- HFS-440 308 080 A **xx** 42 X4
- HFS-440 308 080 A **xx** 42 X4 M

Note: Version with pre-centering on the inner side of the Connector Outer Contact. Centering range: ± 0.6 mm

Spring force rating

The spring-loaded Inner and Outer Conductors are available with different spring forces. The ordering description is derived by adding up the individual values.

	HFS-840 HFS-840 M				HFS-440 HFS-440 M
Spring Force of Inner Conductor (N)	1.3	2.0	1.3	2.0	1.0
Spring Force of Outer Conductor (N)	4.0	6.0	8.0	8.0	4.0
Character for ordering	53	80	93	99	50

Note: (*)

For usage in the case of vibration, shaking, snapping or assembly upside down.

Mechanical Data

HFS-840 and HFS-840 M

	Outer Cond.	Inner Cond.
Working Stroke:	4.0 mm	2.0 mm
Maximum Stroke:	5.0 mm	3.7 mm

Mechanical Data

HFS-440 and HFS-440 M

	Outer Cond.	Inner Cond.
Working Stroke:	2.0 mm	2.0 mm
Maximum Stroke:	3.0 mm	3.0 mm

MMBX / MMCP / MMMPX / MBX / MCX
 SMB / SMC
 SMP (X/MAX) / SMP-L 5SMP / P-5MP
 SMA / PC3.5 / QMA
 BMA / BNC 1.0/2.3
 N / FME / 7/16
 U.FL / W.FL / W.FL2 / X.FL / MM5829
 Reverse SMA / TNC
 IEC / F (75 Ω)
 FAKRA / GT13 / GT16
 Digital
 Switch connector contacting
 PCB test point
 PCB test point side
 Coaxial dipole probe
 Accessories

MCX Signal Conductor Jack

up to 6 GHz
(50 Ω)

HFS-860 / HFS-860 M

Series:

Available Tip Styles:

Ordering Description:

HFS-860 ...

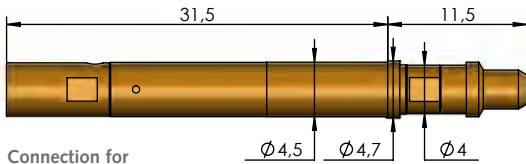

Connection for MCX Plug

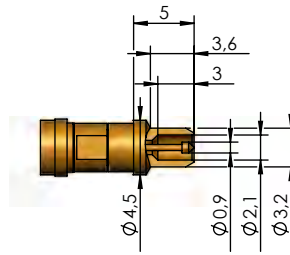

HFS-860 308 090 A **xx** 42 X
HFS-860 308 090 A **xx** 42 X M

Note: Version with pre-centering on the inner side of the Connector Outer Contact. Centering range: ± 0.6 mm

HFS-860 ... M (*)

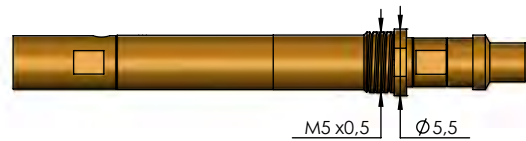

Spring force rating

The spring-loaded Inner and Outer Conductors are available with different spring forces. The ordering description is derived by adding up the individual values.

	HFS-860 HFS-860 M			
	1.3	2.0	1.3	2.0
Spring Force of Inner Conductor (N)	1.3	2.0	1.3	2.0
Spring Force of Outer Conductor (N)	4.0	6.0	8.0	8.0
Character for ordering	53	80	93	99

Note: (*)

For usage in the case of vibration, shaking, snapping or assembly upside down.

Mechanical Data

HFS-860 and HFS-860 M

	Outer Cond.	Inner Cond.
Working Stroke:	4.0 mm	2.0 mm
Maximum Stroke:	5.0 mm	3.7 mm

Contacting of SMB Connectors

Series SMB

Connection Dimensions

Signal Conductor Plug

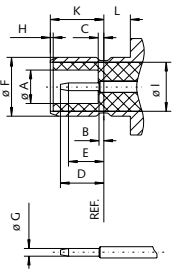

Signal Conductor Jack

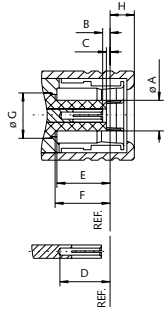

	Signal Conductor Plug		Signal Conductor Jack	
	min.	max.	min.	max.
A	2.08 / .082	-	-	2.06 / .081
B	-	0.18 / .007	0.18 / .007	0.94 / .037
C	-	0.18 / .007	0.18 / .007	-
D	-	2.97 / .117	2.97 / .117	-
E	1.32 / .052	-	3.58 / .141	-
F	3.66 / .144	3.71 / .146	3.58 / .141	-
G	0.48 / .019	0.53 / .021	3.05 / .120 nom.	
H	0.00 / .000	-	-	1.63 / .064
I	3.05 / .120 nom		-	-
K	3.33 / .131	3.58 / .141	-	-
L	1.65 / .065	-	-	-

Example of manufacturer Huber+Suhner:

SMB Signal Conductor Plug

SMB Signal Conductor Plug

SMB Signal Conductor Jack



Contacting of SMC Connectors

Series SMC

Connection Dimensions

Signal Conductor Plug

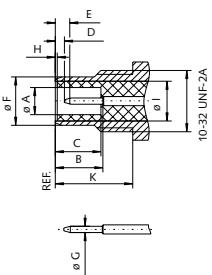

Signal Conductor Jack

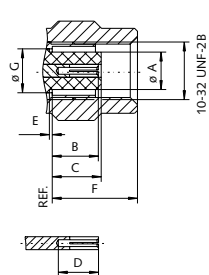

	Signal Conductor Plug		Signal Conductor Jack	
	min.	max.	min.	max.
A	2.08 / .082	-	-	2.06 / .081
B	3.40 / .134	-	2.85 / .112	3.40 / .134
C	3.40 / .134	-	-	3.40 / .134
D	0.61 / .024	-	2.97 / .117	-
E	-	2.13 / .084	0.00 / .000	-
F	-	3.71 / .146	-	5.92 / .233
G	0.48 / .019	0.53 / .021	3.05 / .120 nom.	
H	0.00 / .000	-	-	-
I	3.05 / .120 nom		-	-
K	5.94 / .234	-	-	-

Example of manufacturer Huber+Suhner:

SMC Signal Conductor Plug

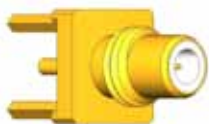

Contents

SMB

Signal Conductor Plug

2 GHz 43

HFS-810, HFS-810 M
HFS-410, HFS-410 M

4 GHz 44

HFS-840, HFS-840 M
HFS-440, HFS-440 M

Signal Conductor Jack

2 GHz 45

HFS-810, HFS-810 M
HFS-410, HFS-410 M

4 GHz 46

HFS-840, HFS-840 M
HFS-440, HFS-440 M

SMC

Signal Conductor Plug

2 GHz 47

HFS-810, HFS-810 M
HFS-410, HFS-410 M

4 GHz 48

HFS-840, HFS-840 M
HFS-440, HFS-440 M

Receptacles (KS) 192 - 194

Spacer of Receptacles (DS) 195

Cable plug assembly (SE) 196 - 199

Tools 200 - 201

Inner Conductor/Signal Conductor 202 - 204

MMBX / MMMPX
MMCK / MMMPX
MBX / MCX
SMB / SMC
SMP (X/MAX)
SMP-L 55MP / P-5MP
SMA / PC3.5
QMA
BMA / BNC
1.0/2.3
N / FME / 7/16
U.FL / W.FL / W.FL2 / X.FL / MM5829
Reverse SMA / TNC
IEC / F (75 Ω)
FAKRA / GT13 / GT16
Digital
Switch connector contacting
PCB test point
PCB test point side
Coaxial dipole probe
Accessories

SMB Connectors

SMC Connectors

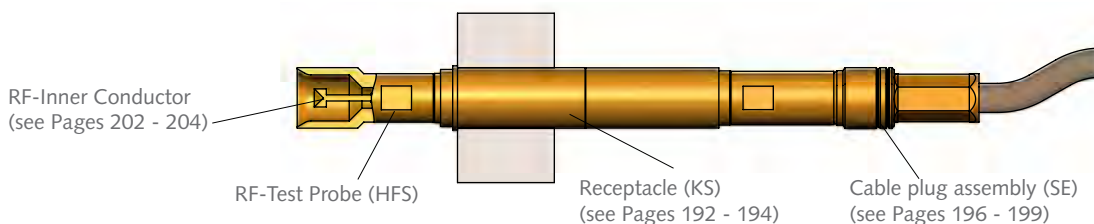

Contacting Example SMB:

Contacting of SMB Signal Conductor Plug

HFS-810 303 150 A 5343 Y

Contacting of SMB Signal Conductor Jack

HFS-810 308 080 A 5342 ZE

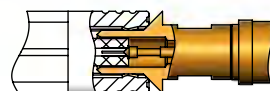
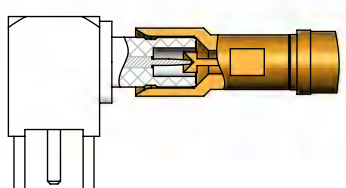

Customizing Example:

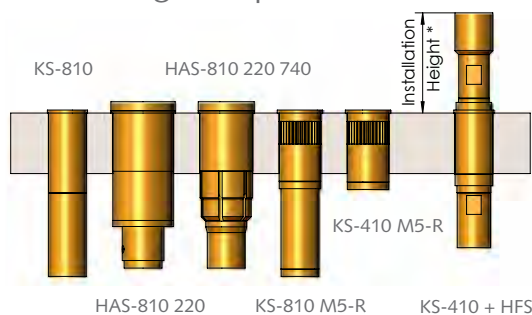

Installation Height in Receptacle		KS-810 (F) KS-410 (F) KS-810 M5-(R/F) KS-410 M5-(R/F)	HAS-810 220 (F) HAS-810 220 740 (F)
Variant		*Installation Height HFS in KS	
SMB Signal Conductor Plug	...Y / ... YM	13.3 mm	14.4 mm
	... Y2 / ... Y2 M		
	... F-Y14 / ... F-Y14 M		
	... Y3 / ... Y3 M		
SMB Signal Conductor Jack	... ZE / ... ZE M	11.8 mm	12.9 mm
SMC Signal Conductor Plug	... Y5 / ... Y5	12.0 mm	13.1 mm

Electrical Data

HFS-810 / 810 M HFS-840 / 840 M

HFS-410 / 410 M HFS-440 / 440 M

Frequency Range with HFS-810/410: up to 2 GHz

Frequency Range with HFS-840/440: up to 4 GHz

Current Rating Outer Conductor: 8–10 A

Current Rating Inner Conductor: 2–3 A

R_i typical Inner Conductor: ≤ 10 mΩ

Impedance Test Probe: 50 Ω

Impedance Cable: 50 Ω

Operating Temperature Range

–40° up to +80° C

Note:

Further details of receptacles with and without flange connection (F) see pages 192 - 194.

Series:

Available Tip Styles:

Ordering Description:

HFS-810 ...

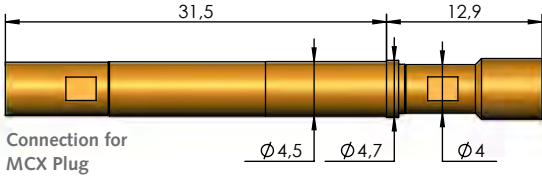

HFS-810 ... M (*)

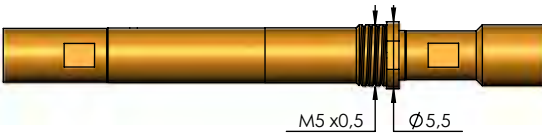

HFS-410 ...

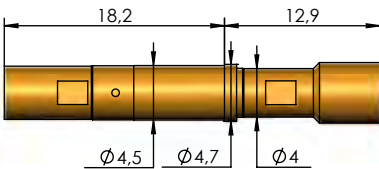

HFS-410 ... M (*)

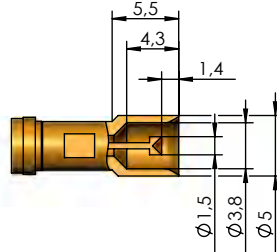
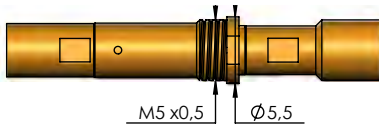

- HFS-810 303 150 A **xx** 43 Y
- HFS-810 303 150 A **xx** 43 Y M
- HFS-410 303 150 A **xx** 43 Y
- HFS-410 303 150 A **xx** 43 Y M

Note: Version with enlarged centering range.
Centering range: ± 0.6 mm

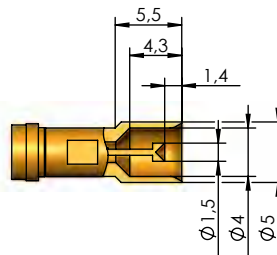

- HFS-810 303 150 A **xx** 43 Y2
- HFS-810 303 150 A **xx** 43 Y2 M
- HFS-410 303 150 A **xx** 43 Y2
- HFS-410 303 150 A **xx** 43 Y2 M

Note: Version with larger centering range and inside diameter of Outer Plunger - for applications with large position errors.
Centering range: ± 0.7 mm

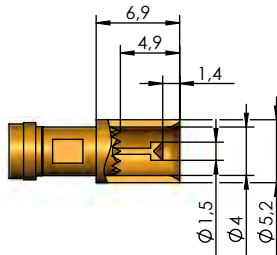

- HFS-810 303 150 A **xx** 43 F-Y14
- HFS-810 303 150 A **xx** 43 F-Y14 M
- HFS-410 303 150 A **xx** 43 F-Y14
- HFS-410 303 150 A **xx** 43 F-Y14 M

Note: Outer plunger with inner serrated tip for application when connector is contaminated.
Centering range: ± 0.7 mm

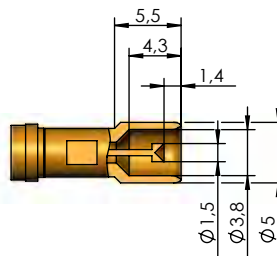

- HFS-810 303 150 A **xx** 43 Y3
- HFS-810 303 150 A **xx** 43 Y3 M
- HFS-410 303 150 A **xx** 43 Y3
- HFS-410 303 150 A **xx** 43 Y3 M

Note: Outer plunger with outer chamfer for pre-centering of SMB Connectors with casing.
Centering range: ± 0.6 mm

Spring force rating

The spring-loaded Inner and Outer Conductor are available with different spring forces. The ordering description is derived by adding up the individual values.

	HFS-810 HFS-810 M				HFS-410 HFS-410 M
Spring Force of Inner Conductor (N)	1.3	2.0	1.3	2.0	1.0
Spring Force of Outer Connector (N)	4.0	6.0	8.0	8.0	4.0
Character for ordering	53	80	93	99	50

Note: (*)

For usage in the case of vibration, shaking, snapping or assembly upside down.

Mechanical Data

HFS-810 and HFS-810 M

	Outer Cond.	Inner Cond.
Working Stroke:	4.0 mm	2.0 mm
Maximum Stroke:	5.0 mm	3.7 mm

Mechanical Data

HFS-410 and HFS-410 M

	Outer Cond.	Inner Cond.
Working Stroke:	2.0 mm	2.0 mm
Maximum Stroke:	3.0 mm	3.0 mm

SMB Signal Conductor Plug

up to 4 GHz
(50 Ω)

HFS-840 / HFS-840 M
HFS-440 / HFS-440 M

Series:

Available Tip Styles:

Ordering Description:

HFS-840 ...

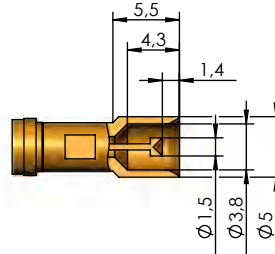
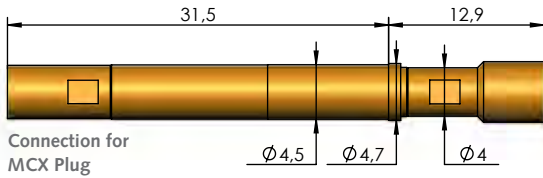

HFS-840 303 150 A **xx** 43 Y
HFS-840 303 150 A **xx** 43 Y M
HFS-440 303 150 A **xx** 43 Y
HFS-440 303 150 A **xx** 43 Y M

Note: Version with enlarged centering range.
Centering range: ± 0.6 mm

HFS-840 ... M (*)

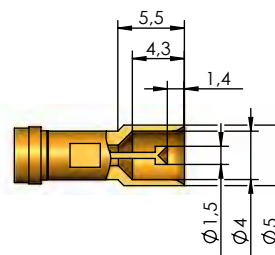
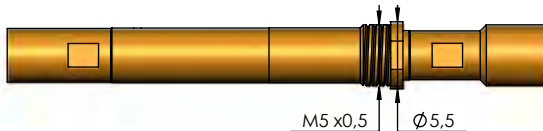

HFS-840 303 150 A **xx** 43 Y2
HFS-840 303 150 A **xx** 43 Y2 M
HFS-440 303 150 A **xx** 43 Y2
HFS-440 303 150 A **xx** 43 Y2 M

Note: Version with larger centering range and inside diameter of Outer Plunger - for applications with large position errors.
Centering range: ± 0.7 mm

HFS-440 ...

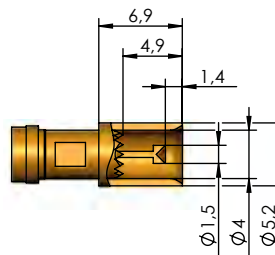
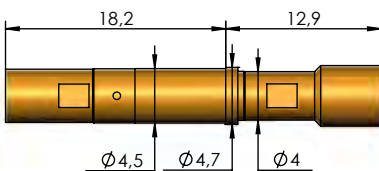

HFS-840 303 150 A **xx** 43 F-Y14
HFS-840 303 150 A **xx** 43 F-Y14 M
HFS-440 303 150 A **xx** 43 F-Y14
HFS-440 303 150 A **xx** 43 F-Y14 M

Note: Outer plunger with inner serrated tip for application when connector is contaminated.
Centering range: ± 0.7 mm

HFS-440 ... M (*)

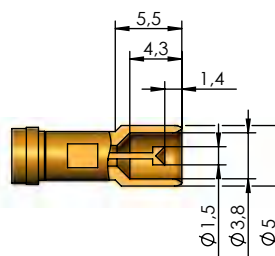
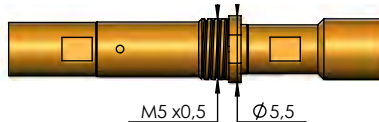

HFS-840 303 150 A **xx** 43 Y3
HFS-840 303 150 A **xx** 43 Y3 M
HFS-440 303 150 A **xx** 43 Y3
HFS-440 303 150 A **xx** 43 Y3 M

Note: Outer plunger with outer chamfer for pre-centering of SMB Connectors with casing.
Centering range: ± 0.6 mm

Spring force rating

The spring-loaded Inner and Outer Conductor are available with different spring forces. The ordering description is derived by adding up the individual values.

	HFS-840 HFS-840 M				HFS-440 HFS-440 M
Spring Force of Inner Conductor (N)	1.3	2.0	1.3	2.0	1.0
Spring Force of Outer Conductor (N)	4.0	6.0	8.0	8.0	4.0
Character for ordering	53	80	93	99	50

Note: (*)

For usage in the case of vibration, shaking, snapping or assembly upside down.

Mechanical Data

HFS-840 and HFS-840 M

	Outer Cond.	Inner Cond.
Working Stroke:	4.0 mm	2.0 mm
Maximum Stroke:	5.0 mm	3.7 mm

Mechanical Data

HFS-440 and HFS-440 M

	Outer Cond.	Inner Cond.
Working Stroke:	2.0 mm	2.0 mm
Maximum Stroke:	3.0 mm	3.0 mm

Series:

Available Tip Styles:

Ordering Description:

HFS-810 ...

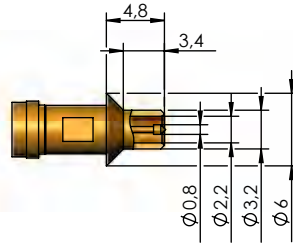
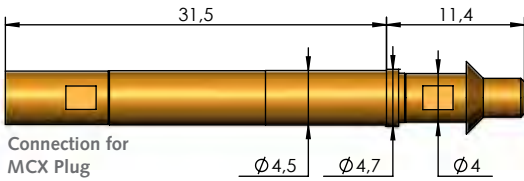

- HFS-810 308 080 A **xx** 42 ZE
- HFS-810 308 080 A **xx** 42 ZE M
- HFS-410 308 080 A **xx** 42 ZE
- HFS-410 308 080 A **xx** 42 ZE M

Note: Version with pre-centering on the inner side of the Connector Outer Contact. Centering range: ± 0.4 mm

HFS-810 ... M (*)

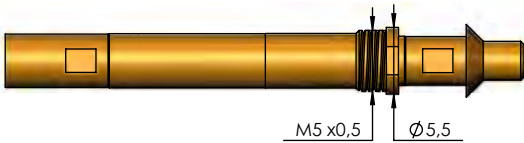

HFS-410 ...

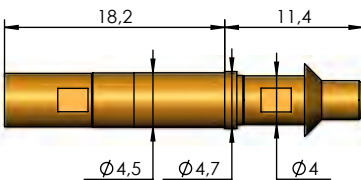

HFS-410 ... M (*)

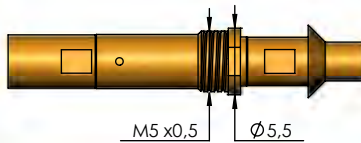

Spring force rating

The spring-loaded Inner and Outer Conductor are available with different spring forces. The ordering description is derived by adding up the individual values.

	HFS-810 HFS-810 M				HFS-410 HFS-410 M
Spring Force of Inner Conductor (N)	1.3	2.0	1.3	2.0	1.0
Spring Force of Outer Conductor (N)	4.0	6.0	8.0	8.0	4.0
Character for ordering	53	80	93	99	50

Note: (*)
For usage in the case of vibration, shaking, snapping or assembly upside down.

Mechanical Data
HFS-810 and HFS-810 M

	Outer Cond.	Inner Cond.
Working Stroke:	4.0 mm	2.0 mm
Maximum Stroke:	5.0 mm	3.7 mm

Mechanical Data
HFS-410 and HFS-410 M

	Outer Cond.	Inner Cond.
Working Stroke:	2.0 mm	2.0 mm
Maximum Stroke:	3.0 mm	3.0 mm

◎ SMB Signal Conductor Jack

up to 4 GHz
(50 Ω)

HFS-840 / HFS-840 M
HFS-440 / HFS-440 M

Series:

Available Tip Styles:

Ordering Description:

HFS-840 ...

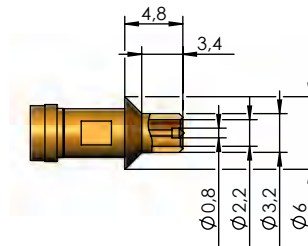
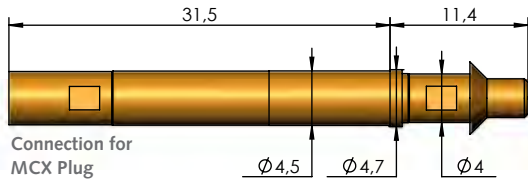

HFS-840 303 080 A **xx** 42 ZE
HFS-840 303 080 A **xx** 42 ZE M
HFS-440 303 080 A **xx** 42 ZE
HFS-440 303 080 A **xx** 42 ZE M

Note: Version with pre-centering on the inner side of the Connector Outer Contact. Centering range: ± 0.4 mm

HFS-840 ... M (*)

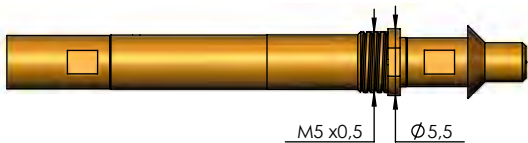

HFS-440 ...

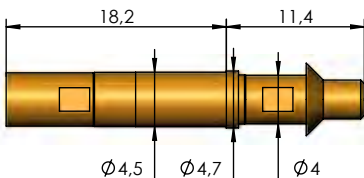

HFS-440 ... M (*)

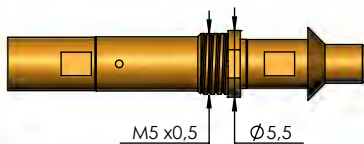

Spring force rating

The spring-loaded Inner and Outer Conductor are available with different spring forces. The ordering description is derived by adding up the individual values.

	HFS-840 HFS-840 M				HFS-440 HFS-440 M
Spring Force of Inner Conductor (N)	1.3	2.0	1.3	2.0	1.0
Spring Force of Outer Conductor (N)	4.0	6.0	8.0	8.0	4.0
Character for ordering	53	80	93	99	50

Note: (*)

For usage in the case of vibration, shaking, snapping or assembly upside down.

Mechanical Data

HFS-840 and HFS-840 M

	Outer Cond.	Inner Cond.
Working Stroke:	4.0 mm	2.0 mm
Maximum Stroke:	5.0 mm	3.7 mm

Mechanical Data

HFS-440 and HFS-440 M

	Outer Cond.	Inner Cond.
Working Stroke:	2.0 mm	2.0 mm
Maximum Stroke:	3.0 mm	3.0 mm

Series:

HFS-810 ...

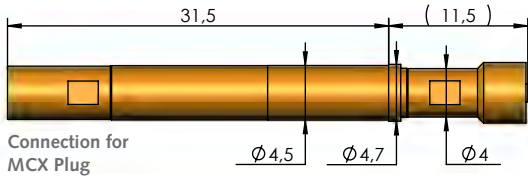

Available Tip Styles:

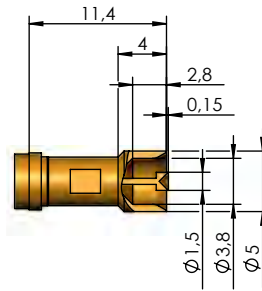

Ordering Description:

- HFS-810 303 150 A **xx** 43 Y5
- HFS-810 303 150 A **xx** 43 Y5 M
- HFS-410 303 150 A **xx** 43 Y5
- HFS-410 303 150 A **xx** 43 Y5 M

Note: Not suitable for SMB contacting, because the stroke of the Inner Conductor would be too short.
Centering range: ± 0.6 mm

HFS-810 ... M (*)

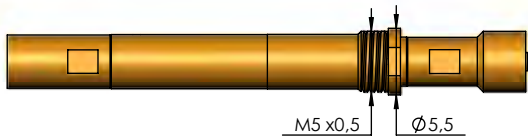

HFS-410 ...

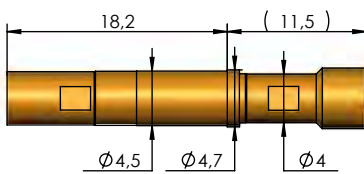

HFS-410 ... M (*)

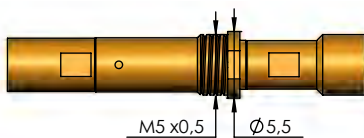

Spring force rating

The spring-loaded Inner and Outer Conductor are available with different spring forces. The ordering description is derived by adding up the individual values.

	HFS-810 HFS-810 M				HFS-410 HFS-410 M
Spring Force of Inner Conductor (N)	1.3	2.0	1.3	2.0	1.0
Spring Force of Outer Conductor (N)	4.0	6.0	8.0	8.0	4.0
Character for ordering	53	80	93	99	50

Note: (*)
For usage in the case of vibration, shaking, snapping or assembly upside down.

Mechanical Data
HFS-810 and HFS-810 M

	Outer Cond.	Inner Cond.
Working Stroke:	4.0 mm	2.0 mm
Maximum Stroke:	5.0 mm	3.7 mm

Mechanical Data
HFS-410 and HFS-410 M

	Outer Cond.	Inner Cond.
Working Stroke:	2.0 mm	2.0 mm
Maximum Stroke:	3.0 mm	3.0 mm

SMC Signal Conductor Plug

up to 4 GHz
(50 Ω)

HFS-840 / HFS-840 M
HFS-440 / HFS-440 M

Series:

Available Tip Styles:

Ordering Description:

HFS-840 ...

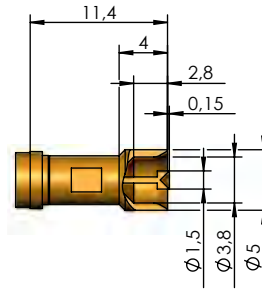
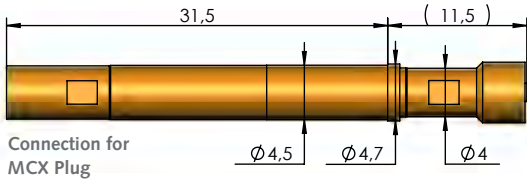

- HFS-840 303 150 A **xx** 43 Y5
- HFS-840 303 150 A **xx** 43 Y5 M
- HFS-440 303 150 A **xx** 43 Y5
- HFS-440 303 150 A **xx** 43 Y5 M

Note: Not suitable for SMB contacting, because the stroke of the Inner Conductor would be too short.
Centering range: ± 0.6 mm

HFS-840 ... M (*)

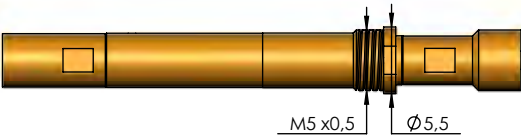

HFS-440 ...

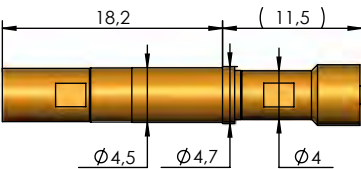

HFS-440 ... M (*)

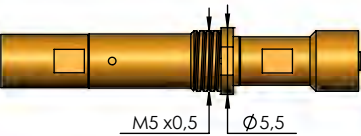

Spring force rating

The spring-loaded Inner and Outer Conductor are available with different spring forces. The ordering description is derived by adding up the individual values.

	HFS-840 HFS-840 M				HFS-440 HFS-440 M
Spring Force of Inner Conductor (N)	1.3	2.0	1.3	2.0	1.0
Spring Force of Outer Conductor (N)	4.0	6.0	8.0	8.0	4.0
Character for ordering	53	80	93	99	50

Note: (*)

For usage in the case of vibration, shaking, snapping or assembly upside down.

Mechanical Data

HFS-840 and HFS-840 M

	Outer Cond.	Inner Cond.
Working Stroke:	4.0 mm	2.0 mm
Maximum Stroke:	5.0 mm	3.7 mm

Mechanical Data

HFS-440 and HFS-440 M

	Outer Cond.	Inner Cond.
Working Stroke:	2.0 mm	2.0 mm
Maximum Stroke:	3.0 mm	3.0 mm

Contacting of SMP Conductors

Series SMP

Connection Dimensions

Signal Conductor Plug

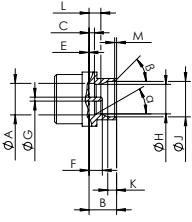

Example of manufacturer Huber+Suhner:

SMP Conductor Plug



	Signalleiter Stecker	
	min.	max.
A	3.15 / .124	3.20 / .126
B	2.74 / .108	2.84 / .112
C	0.52 / .0205	0.60 / .0235
E	0.00 / 0	-
F	1.14 / .045	1.40 / .055
G	0.36 / .014	0.41 / .016
H	2.90 / .114	3.00 / .118
	3.00 / .118	3.10 / .122
J	3.53 / .139	3.68 / .145
K	0.84 / .033	0.94 / .037
L	1.30 / .051	1.45 / .057
	1.37 / .052	1.52 / .060
M	0.08 / .003	1.20 / .008
α	30°	
β	40 / 40	50 / 50

Contacting of SMP-L Conductors

Series SMP-L

Connection Dimensions

Signal Conductor Plug

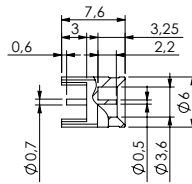

Example of manufacturer Huber+Suhner:

SMP-L Conductor Plug



Contacting of Mini-SMP Conductors

Series Mini-SMP

Connection Dimensions

Signal Conductor Plug

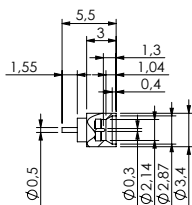

Example of manufacturer Huber+Suhner:

Mini-SMP Conductor Plug



All specifications are subject to change without prior notification

Contents

SMP

Signal Conductor Plug

2 GHz	52
HFS-810, HFS-810 M	
HFS-410, HFS-410 M	
4 GHz	53
HFS-840, HFS-840 M	
HFS-440, HFS-440 M	
6 GHz	54
HFS-856	

SMP-L

Signal Conductor Plug

6 GHz	55
HFS-822	

Mini-SMP

Signal Conductor Plug

6 GHz	56
HFS-860	

SMP-Max

s. page 57 - 58

P-SMP

s. page 59

SMPX

s. page 60

Receptacles (KS)	192 - 194
------------------	-----------

Spacer of Receptacles (DS)	195
----------------------------	-----

Cable plug assembly (SE)	196 - 199
--------------------------	-----------

Tools	200 - 201
-------	-----------

Inner Conductor/Signal Conductor	202 - 204
----------------------------------	-----------

MMBX / MMCPX / MMCPX / MBX / MCBX
SMB / SMC
SMA / PC3.5 QMA
BMA / BNC 1.0/2.3
N / FME / 7/16
U.FL / W.FL / W.FL2 / X.FL / MM5829
Reverse SMA / TNC
IEC / F (75 Ω)
FAKRA / GT13 / GT16
Digital
Switch connector contacting
PCB test point
PCB test point side
Coaxial dipole probe
Accessories

SMP-MAX

Signal Conductor Plug	57
6 GHz HFS-822	
Signal Conductor Jack	58
6 GHz HFS-822	

P-SMP

Signal Conductor Plug	59
6 GHz HFS-822	

SMPX

Signal Conductor Plug	60
12 GHz HFS-865	

Receptacles (KS)	192 - 194
Spacer of Receptacles (DS)	195
Cable plug assembly (SE)	196 - 199
Tools	200 - 201
Inner Conductor/Signal Conductor	202 - 204

Contacting of SMP-MAX Connectors

Series SMP-MAX

Connection Dimensions
Signal Conductor Plug

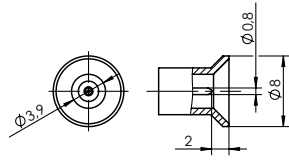

Signal Conductor Jack

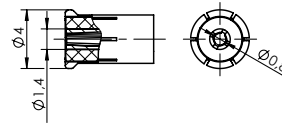

Example of manufacturer Huber+Suhner:

SMP-MAX-Signal Conductor Plug



SMP-MAX Signal Conductor Jack



Contacting of P-SMP Connectors

Series P-SMP

Connection Dimensions

Signal Conductor Plug

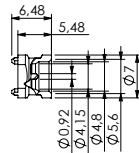

Example of manufacturer Huber+Suhner:

P-SMP Signal Conductor Plug



Contacting of SMPX Connectors

Series SMPX

Connection Dimensions

Signal Conductor Plug

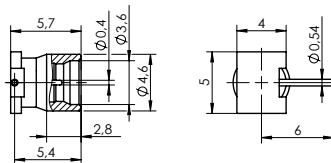

Example of manufacturer Huber+Suhner:

SMPX Signal Conductor Plug



SMP / SMP-L / SSMP / SMP-MAX / P-SMP / SMPX Connector

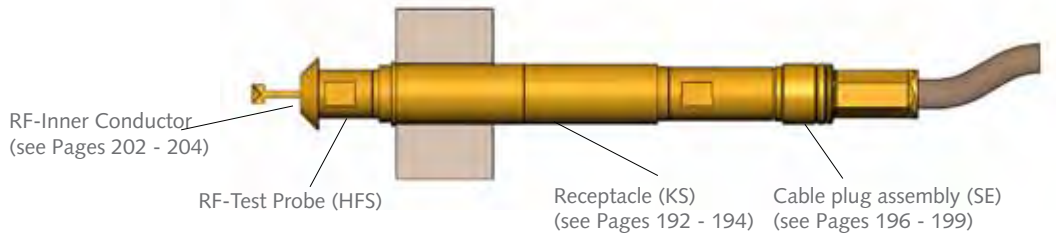

Contacting Example SMP:

Contacting of SMP Signal Conductor Jack
HFS-810 303 150 A 5342 E

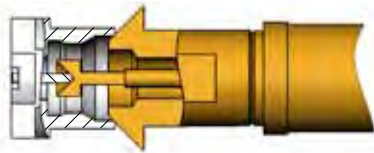

Customizing Example:

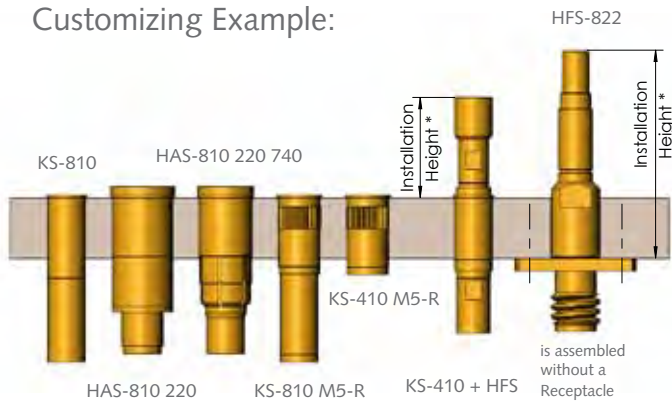

Electrical Data

HFS-810 / 810 M	HFS-840 / 840 M
HFS-410 / 410 M	HFS-440 / 440 M
HFS-822	HFS-856
HFS-860 / 860 M	HFS-865

Frequency Range with HFS-810/410:	up to 2 GHz
Frequency Range with HFS-840/440:	up to 4 GHz
Frequency Range with HFS-822/856:	up to 6 GHz
Frequency Range with HFS-860:	up to 6 GHz
Frequency Range with HFS-865:	up to 12 GHz
Current Rating Outer Conductor:	8–10 A
Current Rating Inner Conductor:	2–3 A
R _i typical Inner Conductor:	≤ 10 mΩ
Impedance Test Probe:	50 Ω
Impedance Cable:	50 Ω

Operating Temperature Range

–40 up to +80° C

Installation Height in Receptacle	KS-810 (F) KS-410 (F) KS-810 M5-(R/F) KS-410 M5-(R/F)	HAS-810 220 (F) HAS-810 220 740 (F)	without KS	
Variant	*Installation Height HFS in KS			
SMP Signal Conductor Plug	... E / ...E M	11.9 mm	13.0 mm	---
	... SMP	---	---	24.1 mm
SMP-L Signal Conductor Plug	...SMPL	---	---	26.5 mm
SSMP Signal Conductor Plug	... SSMP / ...SSMP M	10.9 mm	12.0 mm	---
SMP-MAX Signal Conductor Plug	... SMPM M	---	---	27.5 mm
SMP-MAX Signal Conductor Jack	... SMPM F	---	---	27.5 mm
P-SMP Signal Conductor Plug	... PSMP2	---	---	34.5 mm
SMPX Signal Conductor Plug	... PX F	10.4 mm	11.5 mm	---

Note:

Further details of receptacles with and without flange connection (F) see pages 192 - 194.

⊙ SMP-Signal Conductor Plug

up to 2 GHz
(50 Ω)

HFS-810 / HFS-810 M
HFS-410 / HFS-410 M

Series:

Available
Tip Styles:

Ordering Description:

HFS-810 ...

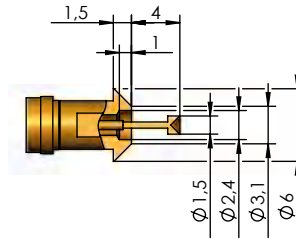
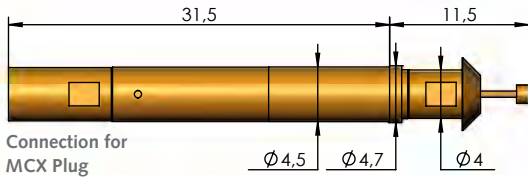

HFS-810 303 150 A **xx** 42 E
HFS-810 303 150 A **xx** 42 E M
HFS-410 303 150 A **xx** 42 E
HFS-410 303 150 A **xx** 42 E M

Note: Version with centering via Inner Conductor Probe.
Centering range: ± 0.4 mm

HFS-810 ... M (*)

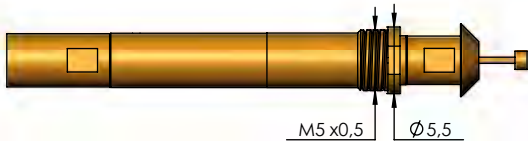

HFS-410 ...

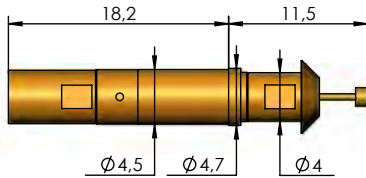

HFS-410 ... M (*)

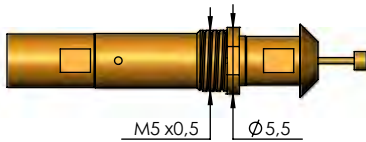

Spring force rating

The spring-loaded Inner and Outer Conductor are available with different spring forces. The ordering description is derived by adding up the individual values.

	HFS-810 HFS-810 M				HFS-410 HFS-410 M
Spring Force of Inner Conductor (N)	1.3	2.0	1.3	2.0	1.0
Spring Force of Outer Conductor (N)	4.0	6.0	8.0	8.0	4.0
Character for ordering	53	80	93	99	50

Note: (*)

For usage in the case of vibration, shaking, snapping or assembly upside down.

Mechanical Data

HFS-810 and HFS-810 M

	Outer Cond.	Inner Cond.
Working Stroke:	4.0 mm	2.0 mm
Maximum Stroke:	5.0 mm	3.7 mm

Mechanical Data

HFS-410 and HFS-410 M

	Outer Cond.	Inner Cond.
Working Stroke:	2.0 mm	2.0 mm
Maximum Stroke:	3.0 mm	3.0 mm

Series:

Available Tip Styles:

Ordering Description:

HFS-840 ...

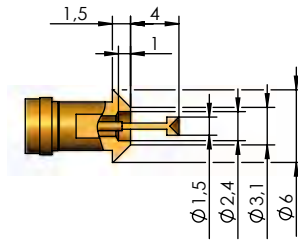
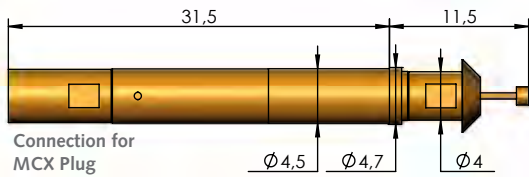

- HFS-840 303 150 A **xx** 42 E
- HFS-840 303 150 A **xx** 42 E M
- HFS-440 303 150 A **xx** 42 E
- HFS-440 303 150 A **xx** 42 E M

Note: Version with centering via Inner Conductor Probe. Centering range: ± 0.4 mm

HFS-840 ... M (*)

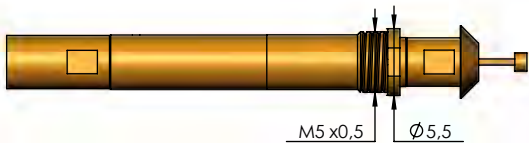

HFS-440 ...

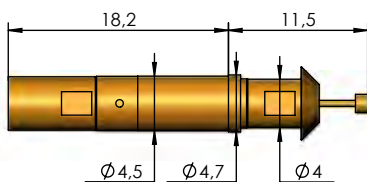

HFS-440 ... M (*)

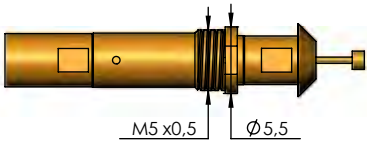

Spring force rating

The spring-loaded Inner and Outer Conductor are available with different spring forces. The ordering description is derived by adding up the individual values.

	HFS-840 HFS-840 M				HFS-440 HFS-440 M
Spring Force of Inner Conductor (N)	1.3	2.0	1.3	2.0	1.0
Spring Force of Outer Conductor (N)	4.0	6.0	8.0	8.0	4.0
Character for ordering	53	80	93	99	50

Note: (*)
For usage in the case of vibration, shaking, snapping or assembly upside down.

Mechanical Data		
HFS-840 and HFS-840 M		
	Outer Cond.	Inner Cond.
Working Stroke:	4.0 mm	2.0 mm
Maximum Stroke:	5.0 mm	3.7 mm

Mechanical Data		
HFS-440 and HFS-440 M		
	Outer Cond.	Inner Cond.
Working Stroke:	2.0 mm	2.0 mm
Maximum Stroke:	3.0 mm	3.0 mm

⊙ SMP Signal Conductor Plug

up to 6 GHz
(50 Ω)

HFS-856

Series:



Available
Tip Styles:

Ordering Description:

HFS-856 ...

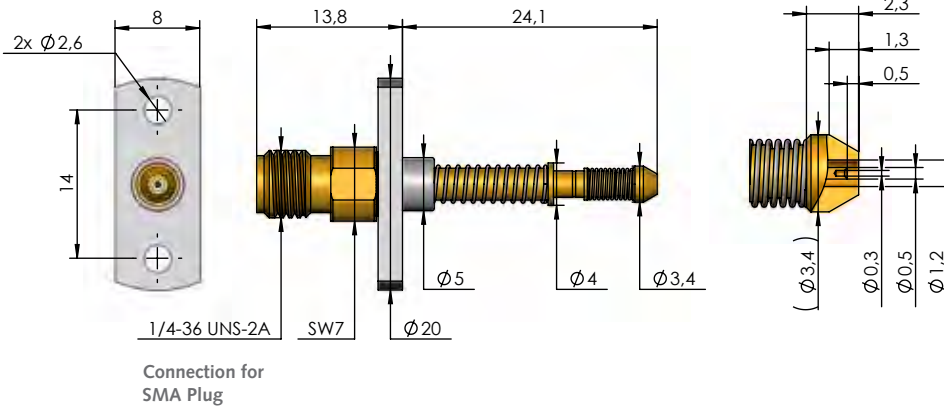

HFS-856 303 051 A **xx** 42 SMP

Note: The HFS-856 is float-mounted and the connection moves out during the working stroke movement. Compensation of radial positioning inaccuracies of the connector by up to $\pm 3,0^\circ$. Centering range: ± 0.7 mm

Spring force rating

The spring-loaded Inner and Outer Conductor are available with different spring forces. The ordering description is derived by adding up the individual values.

Note:

The RF test probes in the HFS-852 series are positioned and fixed with two screws using a flange connection.

For usage in the case of vibration, shaking, snapping or assembly upside down.

	HFS-856
Spring Force of Inner Conductor (N)	1.0
Spring Force of Outer Conductor (N)	4.0
Character for ordering	50

Mechanical Data

HFS-856

	Outer Cond.	Inner Cond.
Working Stroke:	4.2 mm	1.0 mm
Maximum Stroke:	5.2 mm	1.0 mm

Series:

Available Tip Styles:

Ordering Description:

HFS-822 ...

HFS-822 303 090 A **xx** 42 SMPL

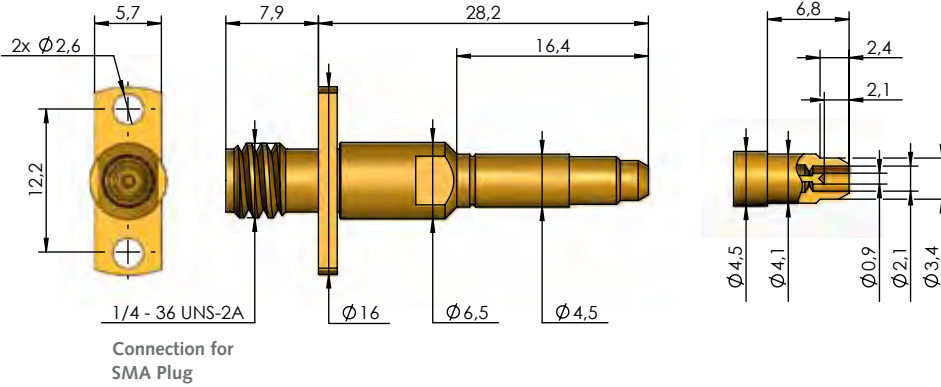

Note: Version with flange connection. No movement of the connection during stroke movement.
Centering range: ± 0.6 mm

Spring force rating

The spring-loaded Inner and Outer Conductor are available with different spring forces. The ordering description is derived by adding up the individual values.

	HFS-822
Spring Force of Inner Conductor (N)	1.0
Spring Force of Outer Conductor (N)	4.0
Character for ordering	50

Note:
The RF test probes in the HFS-822 series are positioned and fixed with two screws using a flange connection.

For usage in the case of vibration, shaking, snapping or assembly upside down.

Mechanical Data		
HFS-822		
	Outer Cond.	Inner Cond.
Working Stroke:	2.0 mm	2.0 mm
Maximum Stroke:	3.0 mm	3.0 mm

SSMP Signal Conductor Plug

up to 6 GHz
(50 Ω)

HFS-860 / HFS-860 M

Series:

Available
Tip Styles:

Ordering Description:

HFS-860 ...

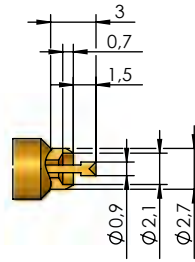
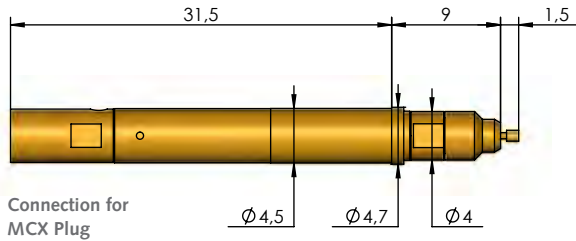

HFS-860 303 090 A **xx** 42 SSMP
HFS-860 303 090 A **xx** 42 SSMP M

Note: Version with precentering on the inner side of the Connector Outer Contact.
Centering range: ± 0.3 mm

HFS-860 ... M (*)

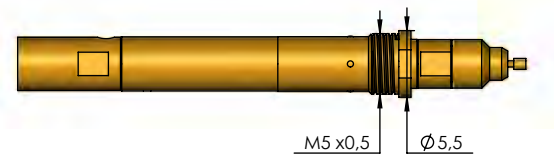

Spring force rating

The spring-loaded Inner and Outer Conductor are available with different spring forces. The ordering description is derived by adding up the individual values.

	HFS-860 HFS-860 M			
Spring Force of Inner Conductor (N)	1.3	2.0	1.3	2.0
Spring Force of Outer Conductor (N)	4.0	6.0	8.0	8.0
Character for ordering	53	80	93	99

Note: (*)

For usage in the case of vibration, shaking, snapping or assembly upside down.

Mechanical Data

HFS-860 and HFS-860 M

	Outer Cond.	Inner Cond.
Working Stroke:	4.0 mm	1.0 mm
Maximum Stroke:	5.0 mm	2.7 mm

MMBX / MMCP / MMMPX
 MBX / MCK
 SMB / SMC
 SMP (X/MAX) / SMP-L / SSMP / P-SMP
 SMA / PC3.5 QMA
 BMA / BNC 1.0/2.3
 N / FME / 7/16
 U.FL / W.FL / W.FL2 / X.FL / MM5829
 Reverse SMA / TNC
 IEC / F (75 Ω)
 FAKRA / GT13 / GT16
 Digital
 Switch connector contacting
 PCB test point
 PCB test point side
 Coaxial dipole probe
 Accessories

Series:

Available Tip Styles:

Ordering Description:

HFS-822 ...

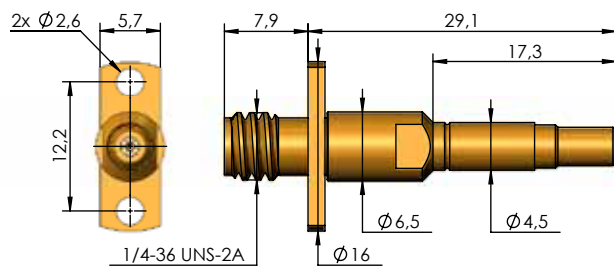

Connection for SMA Plug

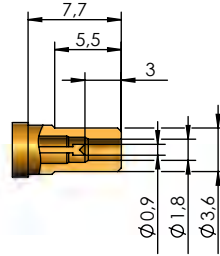

HFS-822 303 090 A **xx** 42 SMPM M

Note: Version with flange connection. No movement of the connection during stroke movement. Pre-centering on the inner side of the Connector Contact.
Centering range: ± 1,0 mm

Spring force rating

The spring-loaded Outer Conductor are available with different spring forces. The ordering description is derived by adding up the individual values.

Note:

The RF test probes in the HFS-822 series are positioned and fixed with two screws using a flange connection.

For usage in the case of vibration, shaking, snapping or assembly upside down.

	HFS-822
Spring Force of Inner Conductor (N)	1.0
Spring Force of Outer Conductor (N)	4.0
Character for ordering	50

Mechanical Data

HFS-822

	Outer Cond.	Inner Cond.
Working Stroke:	2.0 mm	2.0 mm
Maximum Stroke:	3.0 mm	3.0 mm

◎ SMP-MAX Signal Conductor Jack

up to 6 GHz
(50 Ω)

HFS-822

Series:

Available
Tip Styles:

Ordering Description:

HFS-822 ...

HFS-822 308 140 A **xx** 43 SMPM F

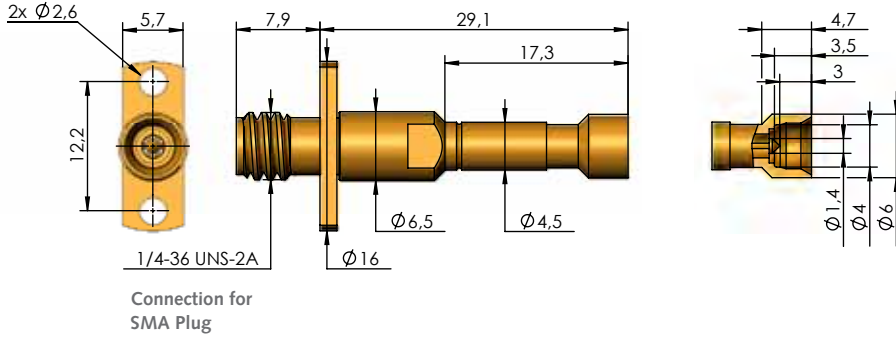

Note: Version with flange connection. No movement of the connection during stroke movement.
Centering range: ± 0.6 mm

Spring force rating

The spring-loaded Inner and Outer Conductor are available with different spring forces. The ordering description is derived by adding up the individual values.

Note:

The RF test probes in the HFS-822 series are positioned and fixed with two screws using a flange connection.

For usage in the case of vibration, shaking, snapping or assembly upside down.

	HFS-822
Spring Force of Inner Conductor (N)	1.0
Spring Force of Outer Conductor (N)	4.0
Character for ordering	50

Mechanical Data

HFS-822

	Outer Cond.	Inner Cond.
Working Stroke:	2.0 mm	2.0 mm
Maximum Stroke:	3.0 mm	3.0 mm

Series:

Available Tip Styles:

Ordering Description:

HFS-822 ...

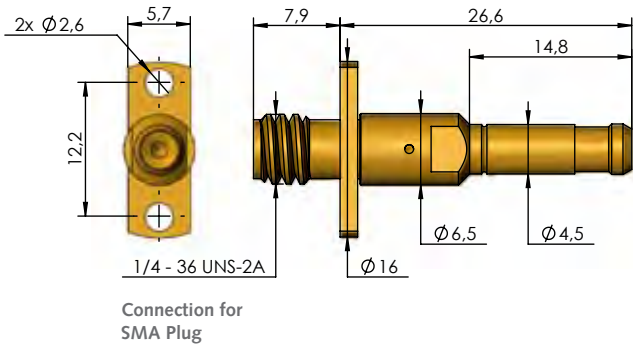

HFS-822 303 090 A **xx** 42 PSMP2

Note: Version with flange connection. No movement of the connection during stroke movement.
Centering range: ± 0.6 mm

Spring force rating

The spring-loaded Inner and Outer Conductor are available with different spring forces. The ordering description is derived by adding up the individual values.

Note:

The RF test probes in the HFS-822 series are positioned and fixed with two screws using a flange connection.

For usage in the case of vibration, shaking, snapping or assembly upside down.

	HFS-822
Spring Force of Inner Conductor (N)	1.0
Spring Force of Outer Conductor (N)	4.0
Character for ordering	50

Mechanical Data

HFS-822

	Outer Cond.	Inner Cond.
Working Stroke:	2.0 mm	2.0 mm
Maximum Stroke:	3.0 mm	3.0 mm

⊙ SMPX-Signal Conductor Plug

up to 12 GHz
(50 Ω)

HFS-865

Series:

Available
Tip Styles:

Ordering Description:

HFS-865 ...

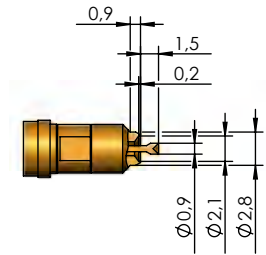
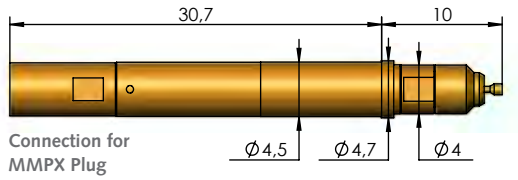

HFS-865 303 090 A **xx** 42 PX F

Note: Version with centering via Inner Conductor Probe. Centering range: ± 0.2 mm

Spring force rating

The spring-loaded Outer Conductor are available with different spring forces. The ordering description is derived by adding up the individual values.

	HFS-865		
Spring Force of Inner Conductor (N)	1.3	1.3	1.3
Spring Force of Outer Conductor (N)	4.0	6.0	8.0
Character for ordering	53	73	93

Mechanical Data

HFS-865

	Outer Cond.	Inner Cond.
Working Stroke:	4.0 mm	1.0 mm
Maximum Stroke:	5.0 mm	1.5 mm

Contacting of SMA Connectors

Series SMA

Connection Dimensions

Signal Conductor Plug

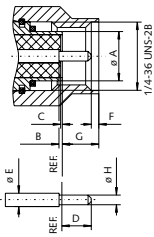

Signal Conductor Jack

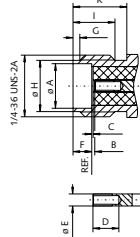

	Signal Conductor Plug		Signal Conductor Jack	
	min.	max.	min.	max.
A	-	4.59 / .181	4.59 / .181	-
B	0.00 / .000	0.25 / .010	0.00 / .000	0.25 / .010
C	0.00 / .000	0.25 / .010	0.00 / .000	0.25 / .010
D	-	2.54 / .100	2.67 / .105	-
E	1.24 / .049	1.29 / .051	1.24 / .049	1.29 / .051
F	0.38 / .015	1.14 / .045	1.88 / .074	1.98 / .078
G	-	3.43 / .135	0.38 / .015	1.14 / .045
H	0.90 / .036	0.94 / .037	5.28 / .208	5.49 / .216
I	-	-	4.32 / .170	-
K	-	-	5.54 / .218	-

Example of manufacturer Huber+Suhner:

SMA Signal Conductor Plug



SMA Signal Conductor Jack



Contacting of PC 3.5 Connectors

Series PC 3.5

Connection Dimensions

Signal Conductor Jack

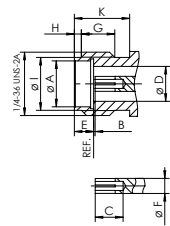

	Signal Conductor Jack	
	min.	max.
A	4.60 / .181	4.63 / .182
B	0.00 / .000	0.08 / .003
C	2.79 / .110	3.18 / .125
D	3.49 / .138	3.51 / .138
E	1.88 / .074	1.98 / .078
F	1.51 / .060	1.52 / .060
G	3.35 / .132	4.62 / .128
H	0.38 / .015	1.14 / .045
I	5.30 / .209	5.40 / .213
K	5.54 / .218	-

Example of manufacturer Huber+Suhner:

PC 3.5 Signal Conductor Jack



Contacting of QMA Connectors

Series QMA

Connection Dimensions

Signal Conductor Jack

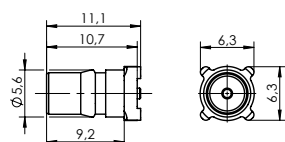

Example of manufacturer Huber+Suhner:

QMA Signal Conductor Jack



All specifications are subject to change without prior notification

Contents

SMA

Signal Conductor Plug

2 GHz 63
HFS-810, HFS-810 M
HFS-410, HFS-410 M

4 GHz 64
HFS-840, HFS-840 M
HFS-440, HFS-440 M

Signal Conductor Jack

2 GHz 65
HFS-810, HFS-810 M
HFS-410, HFS-410 M

4 GHz 66
HFS-840, HFS-840 M
HFS-440, HFS-440 M

6 GHz 67
HFS-860, HFS-860 M

12 GHz 68
HFS-865

PC 3.5

Signal Conductor Jack

12 GHz 69
HFS-865

QMA

Signal Conductor Jack

6 GHz 70
HFS-860, HFS-860 M

Receptacles (KS) 192 - 194

Spacer of Receptacles (DS) 195

Cable plug assembly (SE) 196 - 199

Tools 200 - 201

Inner Conductor/ Signal Conductor 202 - 204

MMBX / MMCPX
MMCK / MMMP
MBX / MCK
SMA / SMC
SMB / SMC
SMP (X/ MAX) / SMP-L 5SMP / P-5MP
SMA / PC3.5 QMA
BMA / BNC 1.0/2.3
N / FME / 7/16
U.FL / W.FL / W.FL2 / X.FL / MM5829
Reverse SMA / TNC
IEC / F (75 Ω)
FAKRA / GT13 / GT16
Digital
Switch connector contacting
PCB test point
PCB test point side
Coaxial dipole probe
Accessories

SMA / PC 3.5 / QMA Connectors

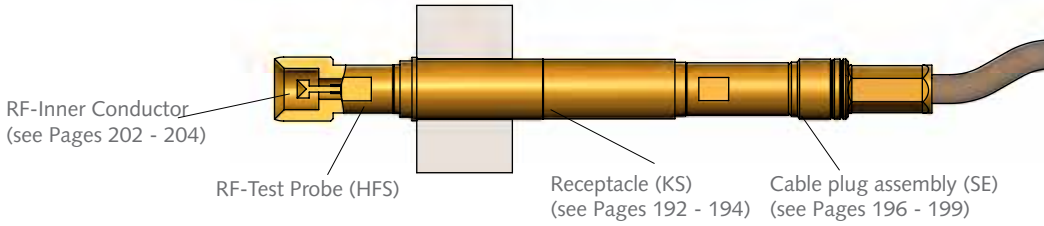

Contacting Example SMA:

Contacting of SMA Signal Conductor Plug
HFS-840 303 150 A 5343 E3

Contacting of SMA Signal Conductor Jack
HFS-840 308 180 A 8042 E

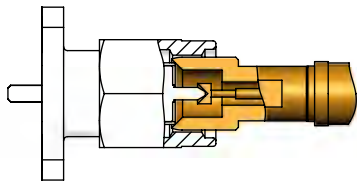

Customizing Example:

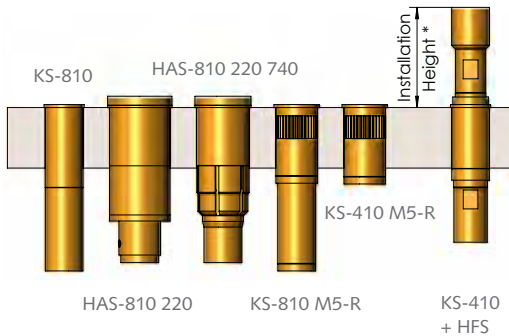

Installation Height in Receptacle		KS-810 (F) KS-410 (F) KS-810 M5-(R/F) KS-410 M5-(R/F)	HAS-810 220 (F) HAS-810 220 740 (F)
Variant		*Installation Height HFS in KS	
SMA Signal Conductor Plug	... E3 / ...E3 M	11.9 mm	13.0 mm
SMA Signal Conductor Jack	...42E / ... 42E M	11.9 mm	13.0 mm
	...43E / ... 43E M	14.1 mm	15.2 mm
	(HFS-860)... E / ... E M	14.1 mm	15.2 mm
	... E1F / ... E1F M	12.2 mm	13.3 mm
PC 3.5 Signal Conductor Jack	... E2F	12.2 mm	13.3 mm
QMA Signal Conductor Jack	... QMA / ... QMA M	18.3 mm	19.4 mm

Electrical Data

HFS-810 / 810 M HFS-840 / 840 M

HFS-410 / 410 M HFS-440 / 440 M

HFS-860 / 860 M HFS-865 / 822

Frequency Range with HFS-810/410: up to 2 GHz

Frequency Range with HFS-840/440: up to 4 GHz

Frequency Range with HFS-860: up to 6 GHz

Frequency Range with HFS-865: up to 12 GHz

Current Rating Outer Conductor: 8–10 A

Current Rating Inner Conductor: 2–3 A

R_i typical Inner Conductor: ≤ 10 mΩ

Impedance Test Probe: 50 Ω

Impedance Cable: 50 Ω

Operating Temperature Range

–40 up to +80° C

Note:

Further details of receptacles with and without flange connection (F) see pages 192 - 194.

Series:

Available Tip Styles:

Ordering Description:

HFS-810 ...

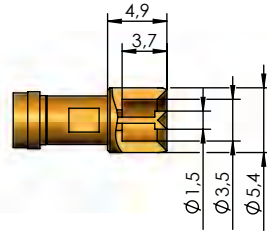
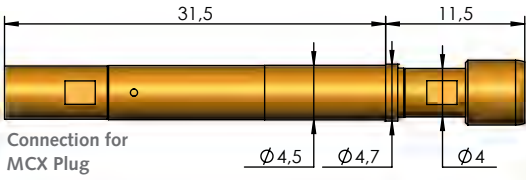

- HFS-810 303 150 A **xx** 43 E3
- HFS-810 303 150 A **xx** 43 E3 M
- HFS-410 303 150 A **xx** 43 E3
- HFS-410 303 150 A **xx** 43 E3 M

Note: Version with pre-centering on the inner side of the Connector Outer Contact. Centering range: ± 0.4 mm

HFS-810 ... M (*)

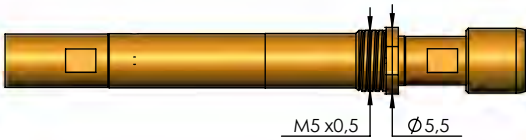

HFS-410 ...

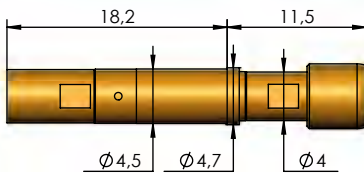

HFS-410 ... M (*)

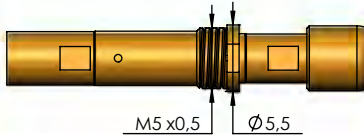

Spring force rating

The spring-loaded Inner and Outer Conductor are available with different spring forces. The ordering description is derived by adding up the individual values.

	HFS-810 HFS-810 M				HFS-410 HFS-410 M
Spring Force of Inner Conductor (N)	1.3	2.0	1.3	2.0	1.0
Spring Force of Outer Conductor (N)	4.0	6.0	8.0	8.0	4.0
Character for ordering	53	80	93	99	50

Note: (*)
For usage in the case of vibration, shaking, snapping or assembly upside down.

Mechanical Data
HFS-810 and HFS-810 M

	Outer Cond.	Inner Cond.
Working Stroke:	4.0 mm	2.0 mm
Maximum Stroke:	5.0 mm	3.7 mm

Mechanical Data
HFS-410 and HFS-410 M

	Outer Cond.	Inner Cond.
Working Stroke:	2.0 mm	2.0 mm
Maximum Stroke:	3.0 mm	3.0 mm

⊙ SMA Signal Conductor Plug

up to 4 GHz
(50 Ω)

HFS-840 / HFS-840 M
HFS-440 / HFS-440 M

Series:

Available Tip Styles:

Ordering Description:

HFS-840 ...

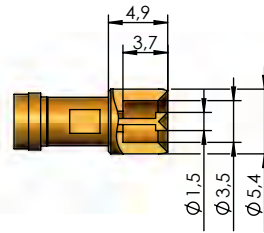
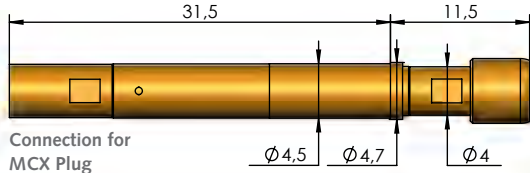

HFS-840 303 150 A **xx** 43 E3
HFS-840 303 150 A **xx** 43 E3 M
HFS-440 303 150 A **xx** 43 E3
HFS-440 303 150 A **xx** 43 E3 M

Note: Version with pre-centering on the inner side of the Connector Outer Contact. Centering range: ± 0.4 mm

HFS-840 ... M (*)

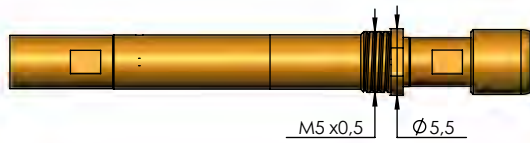

HFS-440 ...

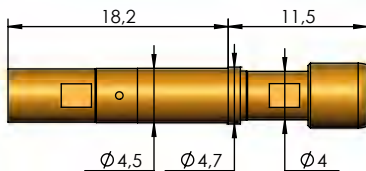

HFS-440 ... M (*)

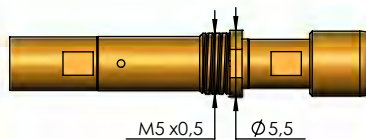

Spring force rating

The spring-loaded Inner and Outer Conductor are available with different spring forces. The ordering description is derived by adding up the individual values.

	HFS-840 HFS-840 M				HFS-440 HFS-440 M
Spring Force of Inner Conductor (N)	1.3	2.0	1.3	2.0	1.0
Spring Force of Outer Conductor (N)	4.0	6.0	8.0	8.0	4.0
Character for ordering	53	80	93	99	50

Note: (*)

For usage in the case of vibration, shaking, snapping or assembly upside down.

Mechanical Data

HFS-840 and HFS-840 M

	Outer Cond.	Inner Cond.
Working Stroke:	4.0 mm	2.0 mm
Maximum Stroke:	5.0 mm	3.7 mm

Mechanical Data

HFS-440 and HFS-440 M

	Outer Cond.	Inner Cond.
Working Stroke:	2.0 mm	2.0 mm
Maximum Stroke:	3.0 mm	3.0 mm

Series:

Available Tip Styles:

Ordering Description:

HFS-810 ...

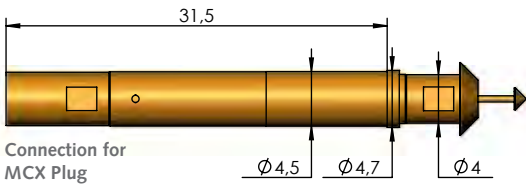

HFS-810 ... M (*)

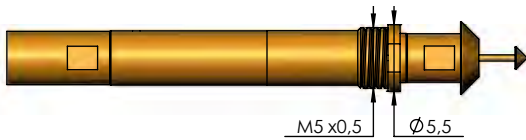

HFS-410 ...

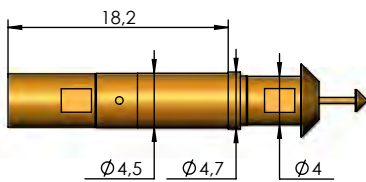

HFS-410 ... M (*)

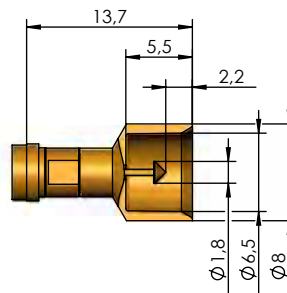
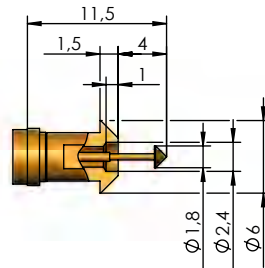
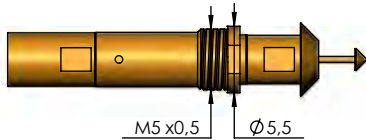

- HFS-810 308 180 A **xx** 42 E
- HFS-810 308 180 A **xx** 42 E M
- HFS-410 308 180 A **xx** 42 E
- HFS-410 308 180 A **xx** 42 E M

Note: Version with pre-centering via Inner Conductor Probe.
Centering range: ± 0.3 mm

- HFS-810 308 180 A **xx** 43 E
- HFS-810 308 180 A **xx** 43 E M
- HFS-410 308 180 A **xx** 43 E
- HFS-410 308 180 A **xx** 43 E M

Note: Version with pre-centering via Outer Plunger.
Centering range: ± 1.0 mm

Spring force rating

The spring-loaded Inner and Outer Conductor are available with different spring forces. The ordering description is derived by adding up the individual values.

	HFS-810 HFS-810 M				HFS-410 HFS-410 M
Spring Force of Inner Conductor (N)	1.3	2.0	1.3	2.0	1.0
Spring Force of Outer Conductor (N)	4.0	6.0	8.0	8.0	4.0
Character for ordering	53	80	93	99	50

Note: (*)

For usage in the case of vibration, shaking, snapping or assembly upside down.

Mechanical Data

HFS-810 and HFS-810 M

	Outer Cond.	Inner Cond.
Working Stroke:	4.0 mm	2.0 mm
Maximum Stroke:	5.0 mm	3.7 mm

Mechanical Data

HFS-410 and HFS-410 M

	Outer Cond.	Inner Cond.
Working Stroke:	2.0 mm	2.0 mm
Maximum Stroke:	3.0 mm	3.0 mm

◎ SMA Signal Conductor Jack

up to 4 GHz
(50 Ω)

HFS-840 / HFS-840 M
HFS-440 / HFS-440 M

Series:

Available Tip Styles:

Ordering Description:

HFS-840 ...

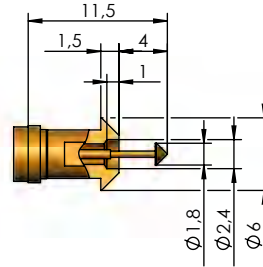
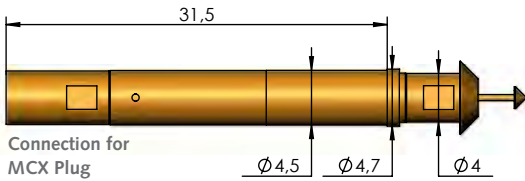

HFS-840 308 180 A **xx** 42 E
HFS-840 308 180 A **xx** 42 E M
HFS-440 308 180 A **xx** 42 E
HFS-440 308 180 A **xx** 42 E M

Note: Version with pre-centering via Inner Conductor Probe.
Centering range: ± 0.3 mm

HFS-840 ... M (*)

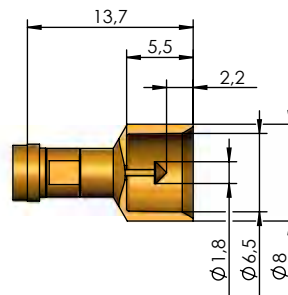
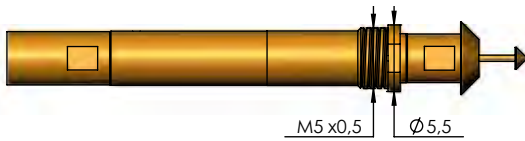

HFS-840 308 180 A **xx** 43 E
HFS-840 308 180 A **xx** 43 E M
HFS-440 308 180 A **xx** 43 E
HFS-440 308 180 A **xx** 43 E M

Note: Version with pre-centering via Outer Plunger.
Centering range: ± 1.0 mm

HFS-440 ...

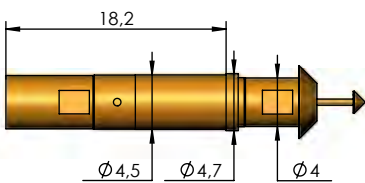

HFS-440 ... M (*)

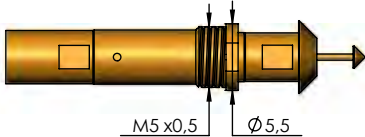

Spring force rating

The spring-loaded Inner and Outer Conductor are available with different spring forces. The ordering description is derived by adding up the individual values.

	HFS-840 HFS-840 M				HFS-440 HFS-440 M
Spring Force of Inner Conductor (N)	1.3	2.0	1.3	2.0	1.0
Spring Force of Outer Conductor (N)	4.0	6.0	8.0	8.0	4.0
Character for ordering	53	80	93	99	50

Note: (*)

For usage in the case of vibration, shaking, snapping or assembly upside down.

Mechanical Data

HFS-840 and HFS-840 M

	Outer Cond.	Inner Cond.
Working Stroke:	4.0 mm	2.0 mm
Maximum Stroke:	5.0 mm	3.7 mm

Mechanical Data

HFS-440 and HFS-440 M

	Outer Cond.	Inner Cond.
Working Stroke:	2.0 mm	2.0 mm
Maximum Stroke:	3.0 mm	3.0 mm

Series:

Available Tip Styles:

Ordering Description:

HFS-860 ...

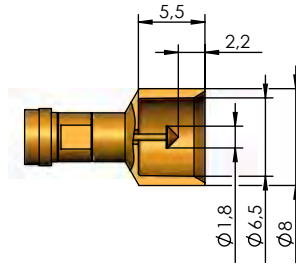
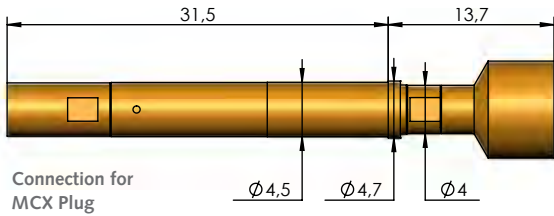

HFS-860 308 180 A **xx** 43 E
HFS-860 308 180 A **xx** 43 E M

Note: Version with pre-centering via Outer Plunger. Centering range: ± 1.0 mm

HFS-860 ... M (*)

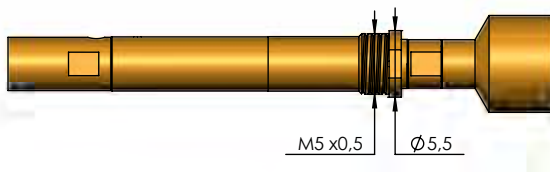

Spring force rating

The spring-loaded Inner and Outer Conductor are available with different spring forces. The ordering description is derived by adding up the individual values.

	HFS-860 HFS-860 M			
Spring Force of Inner Conductor (N)	1.3	2.0	1.3	2.0
Spring Force of Outer Conductor (N)	4.0	6.0	8.0	8.0
Character for ordering	53	80	93	99

Note: (*)

For usage in the case of vibration, shaking, snapping or assembly upside down.

Mechanical Data

HFS-860 and HFS-860 M

	Outer Cond.	Inner Cond.
Working Stroke:	4.0 mm	2.0 mm
Maximum Stroke:	5.0 mm	3.7 mm

MMBX / MMCP / MMCPX / MCB / MCBX
SMB / SMC
SMP (X/MAX) / SMP-L / SMP / P-SMP
SMA / PC3.5 / QMA
BMA / BNC / 1.0/2.3
N / FME / 7/16
U.FL / W.FL / W.FL2 / X.FL / MM5829
Reverse SMA / TNC
IEC / F (75 Ω)
FAKRA / GT13 / GT16
Digital
Switch connector contacting
PCB test point
PCB test point side
Coaxial dipole probe
Accessories

⊙ SMA Signal Conductor Jack

up to 12 GHz
(50 Ω)

HFS-865

Series:

Available
Tip Styles:

Ordering Description:

HFS-865 ...

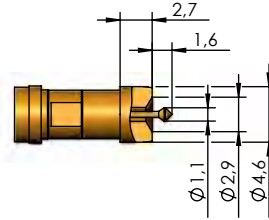
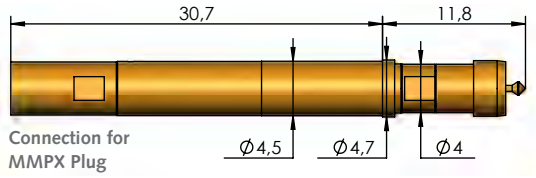

HFS-865 308 110 A **xx** 43 E1 F

Note: Version with centering via Inner Conductor Probe.
Centering range: ± 0.05 mm

Spring force rating

The spring-loaded Outer Conductor are available with different spring forces. The ordering description is derived by adding up the individual values.

	HFS-865		
Spring Force of Inner Conductor (N)	1.3	1.3	1.3
Spring Force of Outer Conductor (N)	4.0	6.0	8.0
Character for ordering	53	73	93

Mechanical Data

HFS-865

	Outer Cond.	Inner Cond.
Working Stroke:	4.0 mm	1.0 mm
Maximum Stroke:	5.0 mm	1.5 mm

Series:

Available Tip Styles:

Ordering Description:

HFS-865 ...

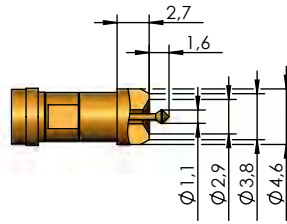
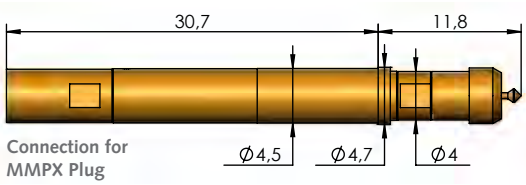

HFS-865 308 110 A **xx** 43 E2 F

Note: Version with centering via Inner Conductor Probe. Centering range: ± 0.3 mm

Spring force rating

The spring-loaded Outer Conductor are available with different spring forces. The ordering description is derived by adding up the individual values.

	HFS-865		
Spring Force of Inner Conductor (N)	1.3	1.3	1.3
Spring Force of Outer Conductor (N)	4.0	6.0	8.0
Character for ordering	53	73	93

Mechanical Data

HFS-865

	Outer Cond.	Inner Cond.
Working Stroke:	4.0 mm	1.0 mm
Maximum Stroke:	5.0 mm	1.5 mm

MMBX / MMCK / MMPX / MBX / MCK
SMB / SMC
SMP (X/MAX) / SMP-L / SSMP / P-SMP
SMA / PC3.5 / QMA
BMA / BNC / 1.0/2.3
N / FME / 7/16
U.FL / W.FL / W.FL2 / X.FL / MM5829
Reverse SMA / TNC
IEC / F (75 Ω)
FAKRA / GT13 / GT16
Digital
Switch connector contacting
PCB test point
PCB test point side
Coaxial dipole probe
Accessories

QMA Signal Conductor Jack

up to 6 GHz
(50 Ω)

HFS-860 / HFS-860 M

Series:

Available Tip Styles:

Ordering Description:

HFS-860 ...

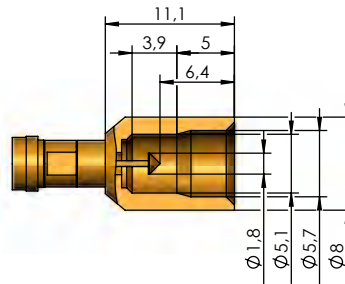
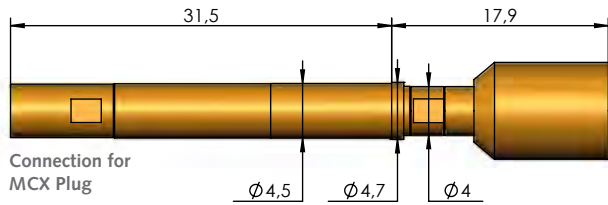

HFS-860 308 180 A **xx** 43 QMA
HFS-860 308 180 A **xx** 43 QMA M

Note: Version with pre-centering via Outer Plunger. Centering range: ± 0.8 mm

HFS-860 ... M (*)

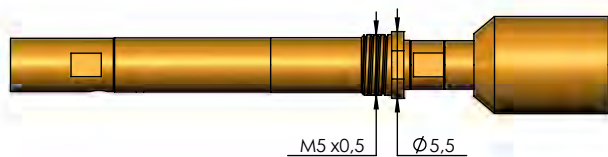

Spring force rating

The spring-loaded Inner and Outer Conductor are available with different spring forces. The ordering description is derived by adding up the individual values.

	HFS-860 HFS-860 M			
Spring Force of Inner Conductor (N)	1.3	2.0	1.3	2.0
Spring Force of Outer Conductor (N)	4.0	6.0	8.0	8.0
Character for ordering	53	80	93	99

Note: (*)

For usage in the case of vibration, shaking, snapping or assembly upside down.

Mechanical Data

HFS-860 and HFS-860 M

	Outer Cond.	Inner Cond.
Working Stroke:	4.0 mm	2.0 mm
Maximum Stroke:	5.0 mm	3.7 mm

Contacting of BMA Connectors

Series BMA

Connection Dimensions

Signal Conductor Plug

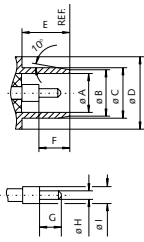

Signal Conductor Jack

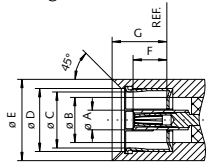

	Signal Conductor Plug		Signal Conductor Jack	
	min.	max.	min.	max.
A	4.09 / .161 nom.		1.78 / .070 nom.	
B	4.88 / .192 nom.		4.09 / .161 nom.	
C	5.31 / .209	5.35 / .211	-	5.08 / .200
D	7.62 / .300 nom.		5.71 / .225	-
E	5.03 / .198	-	7.37 / .290	-
F	3.25 / .128	-	3.05 / .120	3.23 / .127
G	2.29 / .090 nom.		-	5.03 / .198
H	0.90 / .035	0.94 / .037	-	-
I	1.78 / .070 nom.		-	-

Example of manufacturer Huber+Suhner:

BMA Signal Conductor Plug



Contacting of BNC Connectors

Series BNC

Connection Dimensions

Signal Conductor Plug

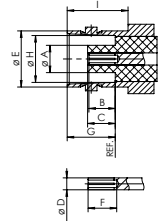

	Signal Conductor Plug	
	min.	max.
A	-	4.72 / .186
B	4.72 / .186	5.23 / .206
C	4.78 / .188	5.28 / .208
D	2.06 / .081	2.21 / .087
E	9.60 / .378	9.70 / .382
F	4.95 / .195	-
G	8.31 / .327	8.51 / .335
H	8.10 / .319	8.15 / .321
I	10.52 / .414	-

Example of manufacturer Huber+Suhner:

BNC Signal Conductor Jack



Contacting of 1.0 / 2.3 Connectors

Series 1.0 / 2.3

Connection Dimensions

Signal Conductor Plug

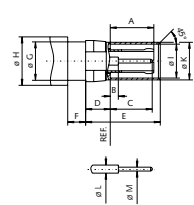

Signal Conductor Jack

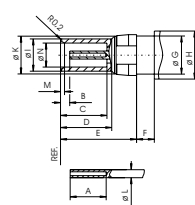

	Signal Conductor Plug		Signal Conductor Jack	
	min.	max.	min.	max.
A	5.40 / .213	5.70 / .224	4.50 / .177	-
B	-	1.15 / .045	1.15 / .045	1.45 / .057
C	5.20 / .205	5.50 / .217	5.80 / .228	5.90 / .232
D	3.05 / .120	3.20 / .126	6.40 / .252	6.50 / .256
E	9.25 / .364	9.35 / .368	9.50 / .374	9.60 / .378
F	2.22 / .087	2.40 / .094	2.22 / .087	2.40 / .094
G	4.76 / .187	4.79 / .189	4.76 / .187	4.79 / .189
H	-	6.00 / .236	-	6.00 / .236
I	4.20 / .165	4.28 / .169	4.03 / .159	4.15 / .163
K	4.66 / .183	4.78 / .188	4.72 / .186	4.75 / .187
L	1.00 / .039 nom.		1.00 / .039 nom.	
M	0.48 / .019	0.52 / .020	0.50 / .020	0.60 / .024
N	-	-	3.00 / .118	3.06 / .120

Example of manufacturer Huber+Suhner:

1.0 / 2.3 Signal Conductor Jack



All specifications are subject to change without prior notification

Contents

BMA

Signal Conductor Plug

2 GHz 73

HFS-810, HFS-810 M
HFS-410, HFS-410 M

4 GHz 74

HFS-840, HFS-840 M
HFS-440, HFS-440 M

BNC

Signal Conductor Jack

2 GHz 75

HFS-810, HFS-810 M
HFS-410, HFS-410 M

4 GHz 76

HFS-840, HFS-840 M
HFS-440, HFS-440 M

1.0 / 2.3

Signal Conductor Jack

2 GHz 77

HFS-810, HFS-810 M
HFS-410, HFS-410 M

4 GHz 78

HFS-840, HFS-840 M
HFS-440, HFS-440 M

Receptacles (KS) 192 - 194

Spacer of Receptacles (DS) 195

Cable plug assembly (SE) 196 - 199

Tools 200 - 201

Inner Conductor/ Signal Conductor 202 - 204

MMBX / MMCP / MMMPX / MBX / MCK
SMB / SMC
SMP (X/MAX) / SMP-L / SSMP / P-SMP
SMA / PC3.5 / QMA
BMA / BNC 1.0/2.3
N / FME / 7/16
U.FL / W.FL / W.FL2 / X.FL / MM5829
Reverse SMA / TNC
IEC / F (75 Ω)
FAKRA / GT13 / GT16
Digital
Switch connector contacting
PCB test point
PCB test point side
Coaxial dipole probe
Accessories

BMA / BNC / 1.0/2.3 Connectors

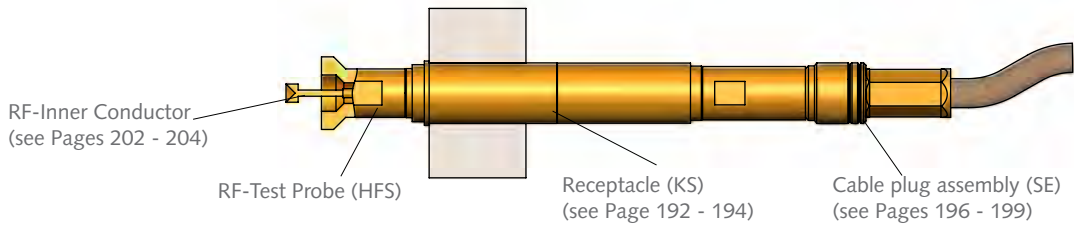

Contacting Example BMA:

Contacting of BMA Signal Conductor Plug

HFS-810 303 150 A 5302 D

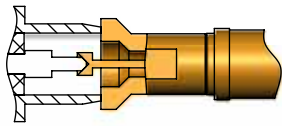

Customizing Example:

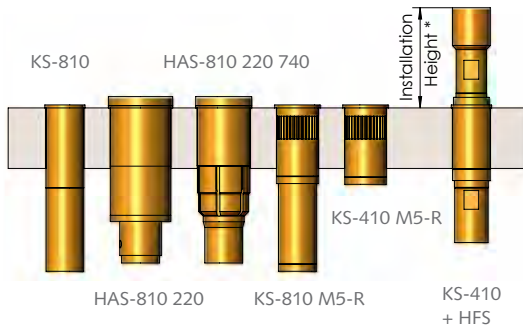

Electrical Data

HFS-810 / 810 M HFS-840 / 840 M

HFS-410 / 410 M HFS-440 / 440 M

HFS-860 / 860 M HFS-865 / 822

Frequency Range with HFS-810/410: up to 2 GHz

Frequency Range with HFS-840/440: up to 4 GHz

Current Rating Outer Conductor: 8–10 A

Current Rating Inner Conductor: 2–3 A

R_i typical Inner Conductor: ≤ 10 mΩ

Impedance Test Probe: 50 Ω

Impedance Cable: 50 Ω

Operating Temperature Range

–40 up to +80° C

Installation Height in Receptacle		KS-810 (F) KS-410 (F) KS-810 M5-(R/F) KS-410 M5-(R/F)	HAS-810 220 (F) HAS-810 220 740 (F)
Variant		*Installation Height HFS in KS	
BMA Signal Conductor Plug	... D / ... D M	11.8 mm	12.9 mm
BNC Signal Conductor Jack	... QS / ... QS M	14.8 mm	15.9 mm
1.0/2.3 Signal Conductor Jack	... T / ... T M	12.8 mm	13.9 mm

Note:

Further details of receptacles with and without flange connection (F) see pages 192 - 194.

Series:

Available Tip Styles:

Ordering Description:

HFS-810 ...

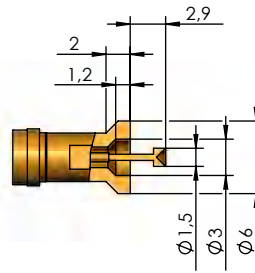
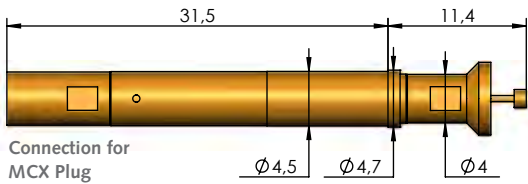

- HFS-810 303 150 A **xx** 02 D
- HFS-810 303 150 A **xx** 02 D M
- HFS-410 303 150 A **xx** 02 D
- HFS-410 303 150 A **xx** 02 D M

Note: Version with pre-centering via Inner Conductor Probe.
Centering range: ± 0.2 mm

HFS-810 ... M (*)

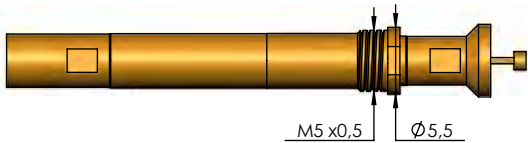

HFS-410 ...

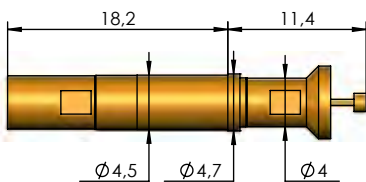

HFS-410 ... M (*)

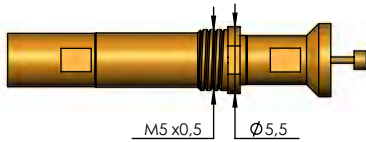

Spring force rating

The spring-loaded Inner and Outer Conductor are available with different spring forces. The ordering description is derived by adding up the individual values.

	HFS-810 HFS-810 M				HFS-410 HFS-410 M
Spring Force of Inner Conductor (N)	1.3	2.0	1.3	2.0	1.0
Spring Force of Outer Conductor (N)	4.0	6.0	8.0	8.0	4.0
Character for ordering	53	80	93	99	50

Note: (*)
For usage in the case of vibration, shaking, snapping or assembly upside down.

Mechanical Data
HFS-810 and HFS-810 M

	Outer Cond.	Inner Cond.
Working Stroke:	4.0 mm	2.0 mm
Maximum Stroke:	5.0 mm	3.7 mm

Mechanical Data
HFS-410 and HFS-410 M

	Outer Cond.	Inner Cond.
Working Stroke:	2.0 mm	2.0 mm
Maximum Stroke:	3.0 mm	3.0 mm

⊙ BMA Signal Conductor Plug

up to 4 GHz
(50 Ω)

HFS-840 / HFS-840 M
HFS-440 / HFS-440 M

Series:

Available
Tip Styles:

Ordering Description:

HFS-840 ...

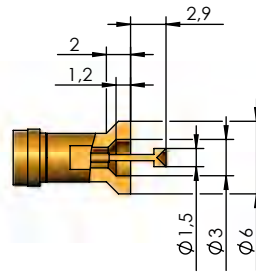
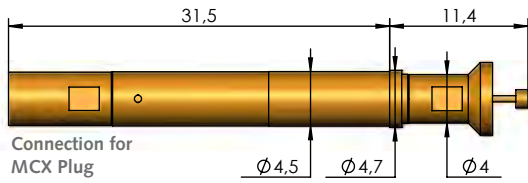

HFS-840 303 150 A **xx** 02 D
HFS-840 303 150 A **xx** 02 D M
HFS-440 303 150 A **xx** 02 D
HFS-440 303 150 A **xx** 02 D M

Note: Version with pre-centering via Inner Conductor Probe.
Centering range: ± 0.2 mm

HFS-840 ... M (*)

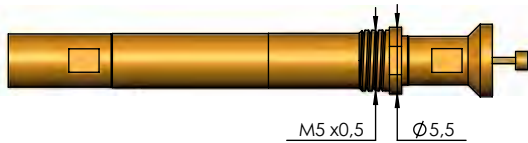

HFS-440 ...

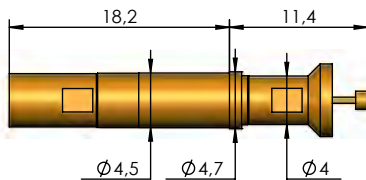

HFS-440 ... M (*)

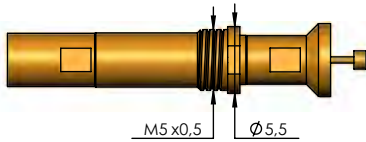

Spring force rating

The spring-loaded Inner and Outer Conductor are available with different spring forces. The ordering description is derived by adding up the individual values.

	HFS-840 HFS-840 M				HFS-440 HFS-440 M
Spring Force of Inner Conductor (N)	1.3	2.0	1.3	2.0	1.0
Spring Force of Outer Conductor (N)	4.0	6.0	8.0	8.0	4.0
Character for ordering	53	80	93	99	50

Note: (*)

For usage in the case of vibration, shaking, snapping or assembly upside down.

Mechanical Data

HFS-840 and HFS-840 M

	Outer Cond.	Inner Cond.
Working Stroke:	4.0 mm	2.0 mm
Maximum Stroke:	5.0 mm	3.7 mm

Mechanical Data

HFS-440 and HFS-440 M

	Outer Cond.	Inner Cond.
Working Stroke:	2.0 mm	2.0 mm
Maximum Stroke:	3.0 mm	3.0 mm

Series:

Available
Tip Styles:

Ordering Description:

HFS-810 ...

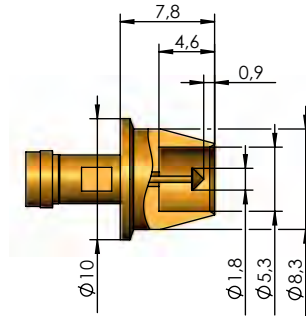
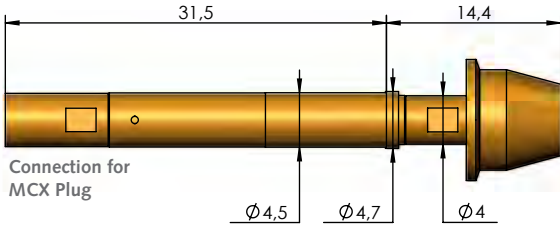

- HFS-810 358 180 A **xx** 42 QS
- HFS-810 358 180 A **xx** 42 QS M
- HFS-410 358 180 A **xx** 42 QS
- HFS-410 358 180 A **xx** 42 QS M

Note: Version with pre-centering on the inner side of the Connector Outer Contact. Centering range: ± 1.4 mm

HFS-810 ... M (*)

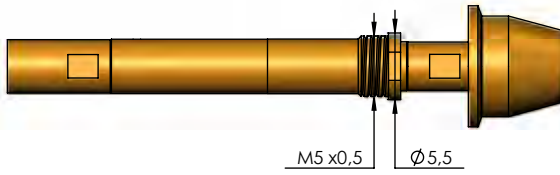

HFS-410 ...

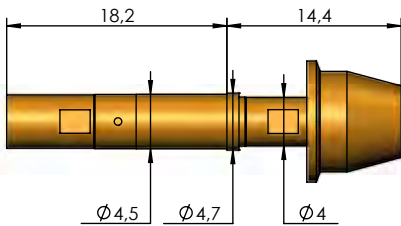

HFS-410 ... M (*)

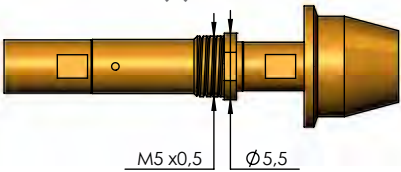

Spring force rating

The spring-loaded Inner and Outer Conductor are available with different spring forces. The ordering description is derived by adding up the individual values.

	HFS-810 HFS-810 M				HFS-410 HFS-410 M
Spring Force of Inner Conductor (N)	1.3	2.0	1.3	2.0	1.0
Spring Force of Outer Conductor (N)	4.0	6.0	8.0	8.0	4.0
Character for ordering	53	80	93	99	50

Note: (*)

For usage in the case of vibration, shaking, snapping or assembly upside down.

Mechanical Data

HFS-810 and HFS-810 M

	Outer Cond.	Inner Cond.
Working Stroke:	4.0 mm	2.0 mm
Maximum Stroke:	5.0 mm	3.2 mm

Mechanical Data

HFS-410 and HFS-410 M

	Outer Cond.	Inner Cond.
Working Stroke:	2.0 mm	2.0 mm
Maximum Stroke:	3.0 mm	2.5 mm

MMBX / MMCK / MMMPX / MBX / MCK
 SMB / SMC
 SMP(X)/MAX / SMP-L/SSMP / P-SMP
 SMA / PC3.5 / QMA
 BMA / BNC / 1.0/2.3
 N / FME / 7/16
 U.FL / W.FL / W.FL2 / X.FL / MM5829
 Reverse SMA / TNC
 IEC / F (75 Ω)
 FAKRA / GT13 / GT16
 Digital
 Switch connector contacting
 PCB test point
 PCB test point side
 Coaxial dipole probe
 Accessories

◎ BNC Signal Conductor Jack

up to 4 GHz
(50 Ω)

HFS-840 / HFS-840 M
HFS-440 / HFS-440 M

Series:

Available Tip Styles:

Ordering Description:

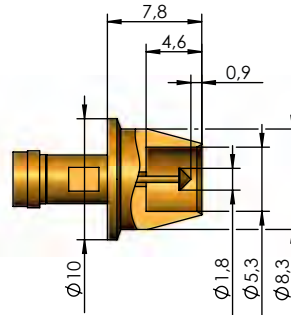
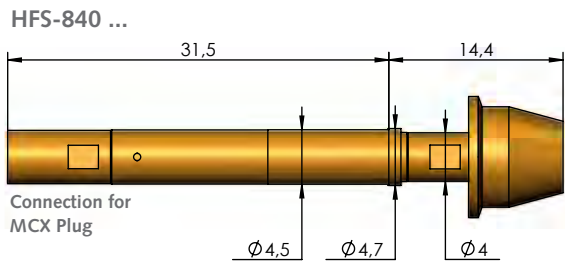

HFS-840 358 180 A **xx** 42 QS
HFS-840 358 180 A **xx** 42 QS M
HFS-440 358 180 A **xx** 42 QS
HFS-440 358 180 A **xx** 42 QS M

Note: Version with pre-centering on the inner side of the Connector Outer Contact
Centering range: ± 1.4 mm

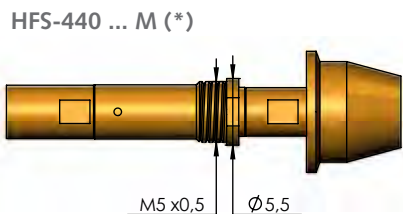
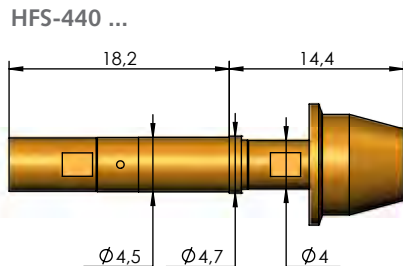
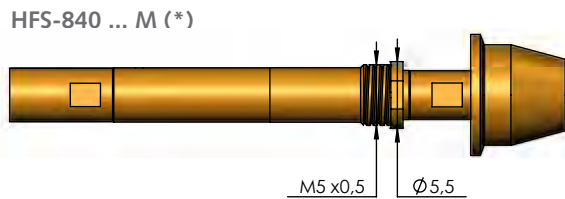

Spring force rating

The spring-loaded Inner and Outer Conductor are available with different spring forces. The ordering description is derived by adding up the individual values.

	HFS-840 HFS-840 M				HFS-440 HFS-440 M
Spring Force of Inner Conductor (N)	1.3	2.0	1.3	2.0	1.0
Spring Force of Outer Conductor (N)	4.0	6.0	8.0	8.0	4.0
Character for ordering	53	80	93	99	50

Note: (*)

For usage in the case of vibration, shaking, snapping or assembly upside down.

Mechanical Data

HFS-840 and HFS-840 M

	Outer Cond.	Inner Cond.
Working Stroke:	4.0 mm	2.0 mm
Maximum Stroke:	5.0 mm	3.2 mm

Mechanical Data

HFS-440 and HFS-440 M

	Outer Cond.	Inner Cond.
Working Stroke:	2.0 mm	2.0 mm
Maximum Stroke:	3.0 mm	2.5 mm

Series:

Available Tip Styles:

Ordering Description:

HFS-810 ...

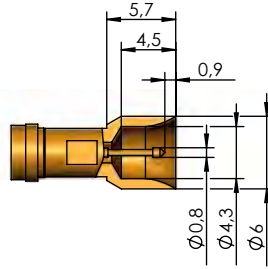
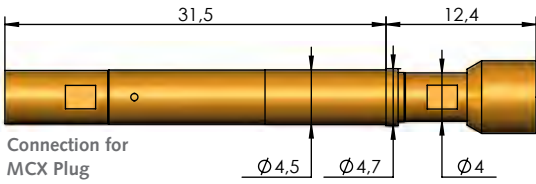

- HFS-810 308 080 A **xx** 43 T
- HFS-810 308 080 A **xx** 43 T M
- HFS-410 308 080 A **xx** 43 T
- HFS-410 308 080 A **xx** 43 T M

Note:
Centering range: ± 0.6 mm

HFS-810 ... M (*)

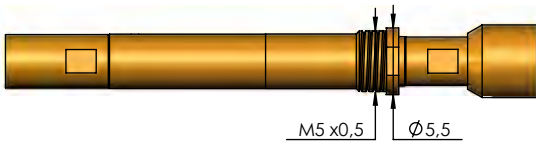

HFS-410 ...

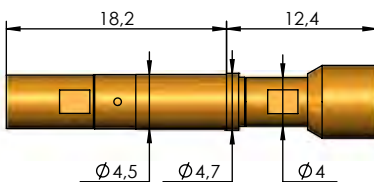

HFS-410 ... M (*)

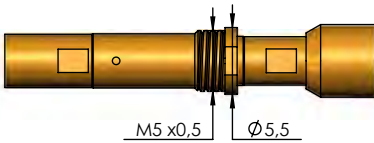

Spring force rating

The spring-loaded Inner and Outer Conductor are available with different spring forces. The ordering description is derived by adding up the individual values.

	HFS-810 HFS-810 M				HFS-410 HFS-410 M
Spring Force of Inner Conductor (N)	1.3	2.0	1.3	2.0	1.0
Spring Force of Outer Conductor (N)	4.0	6.0	8.0	8.0	4.0
Character for ordering	53	80	93	99	50

Note: (*)

For usage in the case of vibration, shaking, snapping or assembly upside down.

Mechanical Data

HFS-810 and HFS-810 M

	Outer Cond.	Inner Cond.
Working Stroke:	4.0 mm	2.0 mm
Maximum Stroke:	5.0 mm	3.7 mm

Mechanical Data

HFS-410 and HFS-410 M

	Outer Cond.	Inner Cond.
Working Stroke:	2.0 mm	2.0 mm
Maximum Stroke:	3.0 mm	3.0 mm

MMBX / MMCP / MMMPX / MBX / MCB
 SMB / SMC
 SMP (X/MAX) / SMP-L / SSMP / P-SMP
 SMA / PC3.5 / QMA
 BMA / BNC / 1.0/2.3
 N / FME / 7/16
 U.FL / W.FL / W.FL2 / X.FL / MM5829
 Reverse SMA / TNC
 IEC / F (75Ω)
 FAKRA / GT13 / GT16
 Digital
 Switch connector contacting
 PCB test point
 PCB test point side
 Coaxial dipole probe
 Accessories

◎ 1.0 / 2.3 Signal Conductor Jack

up to 4 GHz
(50 Ω)

HFS-840 / HFS-840 M
HFS-440 / HFS-440 M

Series:

Available
Tip Styles:

Ordering Description:

HFS-840 ...

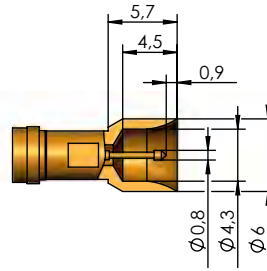
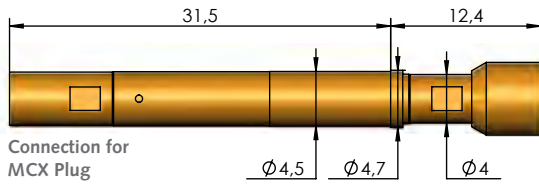

HFS-840 308 080 A **xx** 43 T
HFS-840 308 080 A **xx** 43 T M
HFS-440 308 080 A **xx** 43 T
HFS-440 308 080 A **xx** 43 T M

Note:
Centering range: ± 0.6 mm

HFS-840 ... M (*)

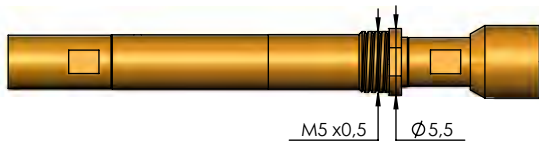

HFS-440 ...

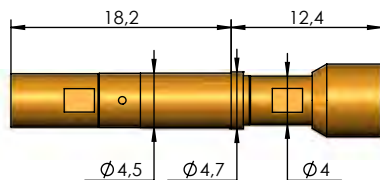

HFS-440 ... M (*)

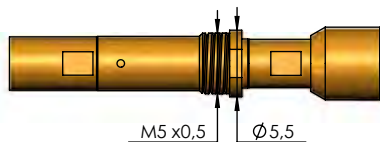

Spring force rating

The spring-loaded Inner and Outer Conductor are available with different spring forces. The ordering description is derived by adding up the individual values.

	HFS-840 HFS-840 M				HFS-440 HFS-440 M
Spring Force of Inner Conductor (N)	1.3	2.0	1.3	2.0	1.0
Spring Force of Outer Conductor (N)	4.0	6.0	8.0	8.0	4.0
Character for ordering	53	80	93	99	50

Note: (*)

For usage in the case of vibration, shaking, snapping or assembly upside down.

Mechanical Data

HFS-840 and HFS-840 M

	Outer Cond.	Inner Cond.
Working Stroke:	4.0 mm	2.0 mm
Maximum Stroke:	5.0 mm	3.7 mm

Mechanical Data

HFS-440 and HFS-440 M

	Outer Cond.	Inner Cond.
Working Stroke:	2.0 mm	2.0 mm
Maximum Stroke:	3.0 mm	3.0 mm

Contacting of N Connectors

Series N

Connection Dimensions

Signal Conductor Plug

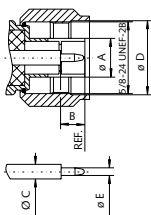

Signal Conductor Jack

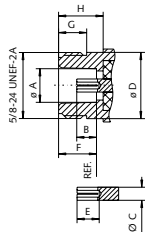

	Signal Conductor Plug		Signal Conductor Jack	
	min.	max.	min.	max.
A	-	8.38 / .330	8.03 / .316	8.13 / .320
B	5.33 / .210	5.84 / .230	4.75 / .187	5.26 / .207
C	-	3.15 / .124	-	3.15 / .124
D	16.00 / .630	-	-	15.93 / .627
E	1.60 / .063	1.68 / .066	5.33 / .210	-
F	-	-	9.04 / .356	9.19 / .362
G	-	-	6.76 / .266	-
H	-	-	10.72 / .422	8.15 / .321

Example of manufacturer Huber+Suhner:

N Signal Conductor Jack



Contacting of FME Connectors

Series FME

Connection Dimensions

Signal Conductor Plug

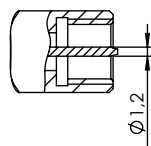

Example:

FME Signal Conductor Plug



Contacting of 7/16 Connectors

Series 7/16

Connection Dimensions

Signal Conductor Plug

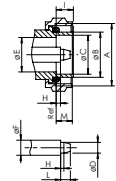

Signal Conductor Jack

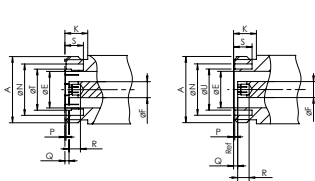

Example of manufacturer Huber+Suhner:

7/16 Signal Conductor Jack



	Signal Conductor Plug		Signal Conductor Jack	
	min.	max.	min.	max.
A	M29 x 1.5		M29 x 1.5	
B	20.60 / .811	21.40 / .843	-	-
C	18.03 / .710	18.21 / .717	-	-
D	4.96 / .195	5.04 / .198	-	-
E	15.85 / .624	16.25 / .640	15.85 / .624	16.25 / .640
F	7.00 / .276 nom.		7.00 / .276 nom.	
G	1.40 / .055	1.60 / .063	-	-
H	1.47 / .058	1.77 / .070	-	-
I	7.00 / .276	8.00 / .315	-	-
K	-	-	10.00 / .394	-
L	-	4.50 / .177	-	-
M	7.00 / .276	9.00 / .354	-	-
N	-	-	22.10 / .870	22.90 / .902
P	-	-	0.50 / .020	0.70 / .028
Q	-	-	1.77 / .070	2.07 / .082
R	-	-	5.00 / .197	-
S	-	-	8.10 / .319	-
T	-	-	-	18.50 / .728
U	-	-	-	18.00 / .709

All specifications are subject to change without prior notification

Contents

N

Signal Conductor Jack

2 GHz
HFS-810, HFS-810 M
HFS-410, HFS-410 M

81

6 GHz
HFS-860, HFS-860 M

82

FME

Signal Conductor Plug

2 GHz
HFS-810, HFS-810 M
HFS-410, HFS-410 M

83

4 GHz
HFS-840, HFS-840 M
HFS-440, HFS-440 M

84

7/16

Signal Conductor Jack

7,5 GHz
HFS-864

85

Receptacles (KS)

192 - 194

Spacer of Receptacles (DS)

195

Cable plug assembly (SE)

196 - 199

Tools

200 - 201

Inner Conductor/
Signal Conductor

202 - 204

MMBX / MMCPX / MCB / MCK
SMB / SMC
SMP (X/MAX) / SMP-L / SMP-P
SMA / PC3.5 QMA
BMA / BNC 1.0/2.3
N / FME / 7/16
U.FL / W.FL / W.FL2 / X.FL / MM5829
Reverse SMA / TNC
IEC / F (75Ω)
FAKRA / GT13 / GT16
Digital
Switch connector contacting
PCB test point
PCB test point side
Coaxial dipole probe
Accessories

N / FME / 7/16 Connectors

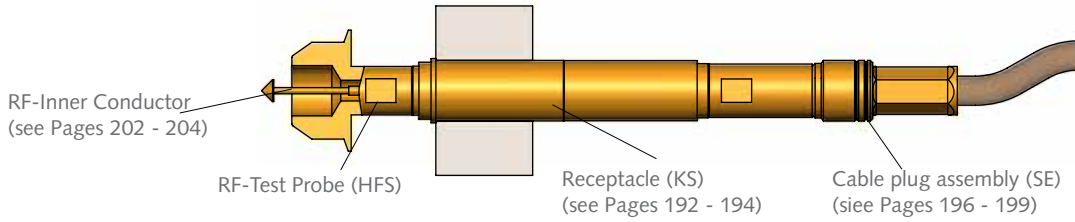

Contacting Example N:

Contacting of N Signal Conductor Jack

HFS-810 358 180 A 5342 Q

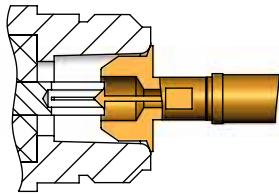

Customizing Example:

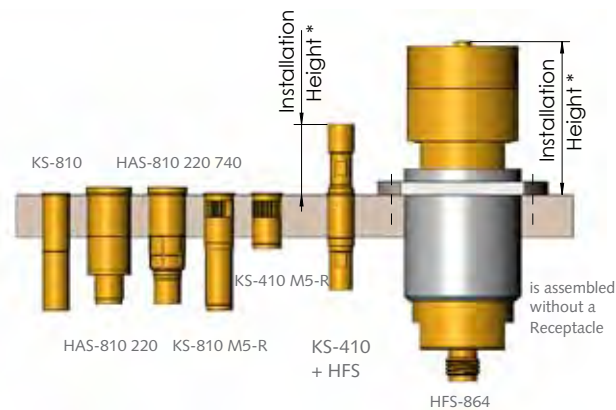

Installation Height in Receptacle		KS-810 (F) KS-410 (F) KS-810 M5-(R/F) KS-410 M5-(R/F)	HAS-810 220 (F) HAS-810 220 740 (F)	without KS
Variant		*Installation Height HFS in KS		
N Signal Conductor Jack	... Q / ... Q M	13.9 mm	15.0 mm	---
	(HFS-860) ... Q / ... Q M	14.7 mm	15.8 mm	---
FME Signal Conductor Plug	... W / ... W M	13.9 mm	15.0 mm	---
7/16 Signal Conductor Jack	...F716	---	---	28.9 mm

Electrical Data

HFS-810 / 810 M HFS-840 / 840 M

HFS-410 / 410 M HFS-440 / 440 M

HFS-860 / 860 M HFS-864

Frequency Range with HFS-810/410: up to 2 GHz

Frequency Range with HFS-840/440: up to 4 GHz

Frequency Range with HFS-860: up to 6 GHz

Frequency Range with HFS-864: up to 7.5 GHz

Current Rating Outer Conductor: 8–10 A

Current Rating Inner Conductor: 2–3 A

R_i typical Inner Conductor: ≤ 10 mΩ

Impedance Test Probe: 50 Ω

Impedance Cable: 50 Ω

Operating Temperature Range

–40 up to +80° C

Note:

Further details of receptacles with and without flange connection (F) see pages 192 - 194.

Series:

Available Tip Styles:

Ordering Description:

HFS-810 ...

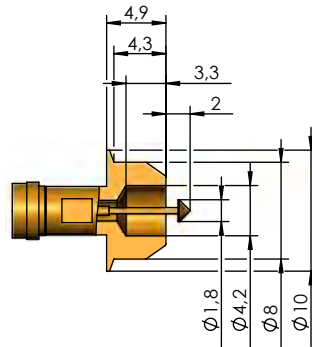
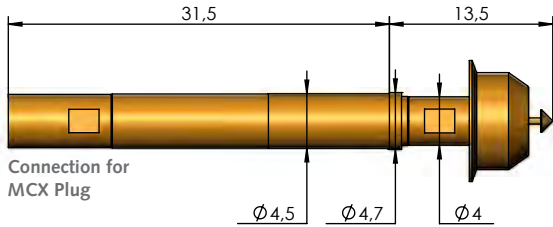

- HFS-810 358 180 A **xx** 42 Q
- HFS-810 358 180 A **xx** 42 Q M
- HFS-410 358 180 A **xx** 42 Q
- HFS-410 358 180 A **xx** 42 Q M

Note: Version with pre-centering on the inner side of the Connector Outer Contact. Centering Range: ± 0.8 mm

HFS-810 ... M (*)

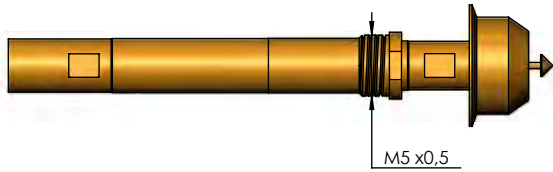

HFS-410 ...

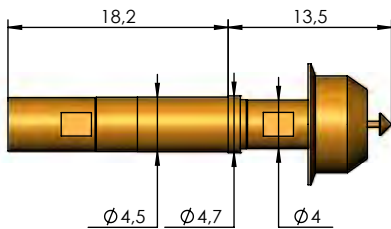

HFS-410 ... M (*)

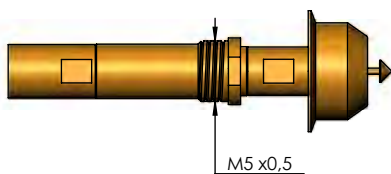

Spring force rating

The spring-loaded Inner and Outer Conductor are available with different spring forces. The ordering description is derived by adding up the individual values.

	HFS-810 HFS-810 M				HFS-410 HFS-410 M
Spring Force of Inner Conductor (N)	1.3	2.0	1.3	2.0	1.0
Spring Force of Outer Conductor (N)	4.0	6.0	8.0	8.0	4.0
Character for ordering	53	80	93	99	50

Note: (*)

For usage in the case of vibration, shaking, snapping or assembly upside down.

Mechanical Data

HFS-810 und HFS-810 M

	Outer Cond.	Inner Cond.
Working Stroke:	4.0 mm	2.0 mm
Maximum Stroke:	5.0 mm	3.7 mm

Mechanical Data

HFS-410 und HFS-410 M

	Outer Cond.	Inner Cond.
Working Stroke:	2.0 mm	2.0 mm
Maximum Stroke:	3.0 mm	3.0 mm

MMBX / MMCP / MMMPX / MMBX / MCBX
 SMB / SMC
 SMP (X/MAX) / SMP-L / SSMP / P-SMP
 SMA / PC3.5 / QMA
 BMA / BNC / 1.0/2.3
 N / FME / 7/16
 U.FL / W.FL / W.FL2 / X.FL / MM5829
 Reverse SMA / TNC
 IEC / F (75 Ω)
 FAKRA / GT13 / GT16
 Digital
 Switch connector contacting
 PCB test point
 PCB test point side
 Coaxial dipole probe
 Accessories

◎ N Signal Conductor Jack

up to 6 GHz
(50 Ω)

HFS-860 / HFS-860 M

Series:

Available Tip Styles:

Ordering Description:

HFS-860 ...

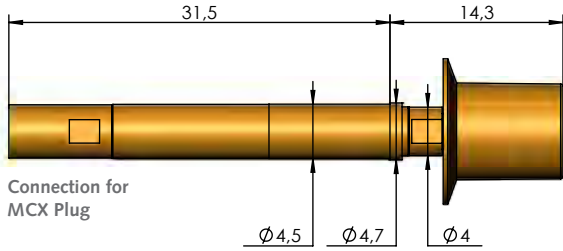

HFS-860 ... M (*)

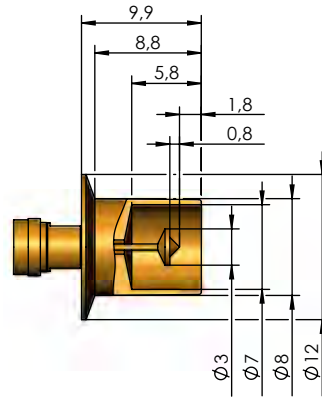
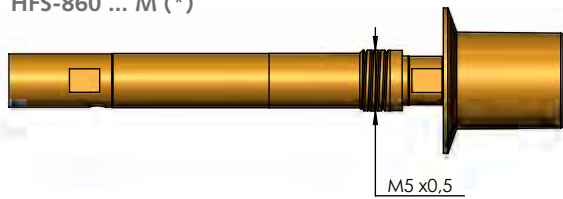

HFS-860 358 300 A **xx** 42 Q
HFS-860 358 300 A **xx** 42 Q M

Note: Version with pre-centering on the inner side of the Connector Outer Contact. Centering range: ± 0.8 mm

Spring force rating

The spring-loaded Inner and Outer Conductor are available with different spring forces. The ordering description is derived by adding up the individual values.

	HFS-860 HFS-860 M			
	Spring Force of Inner Conductor (N)	1.3	2.0	1.3
Spring Force of Outer Conductor (N)	4.0	6.0	8.0	8.0
Character for ordering	53	80	93	99

Note: (*)

For usage in the case of vibration, shaking, snapping or assembly upside down.

Mechanical Data

HFS-860 and HFS-860 M

	Outer Cond.	Inner Cond.
Working Stroke:	4.0 mm	2.0 mm
Maximum Stroke:	5.0 mm	3.7 mm

Series:

Available Tip Styles:

Ordering Description:

HFS-810 ...

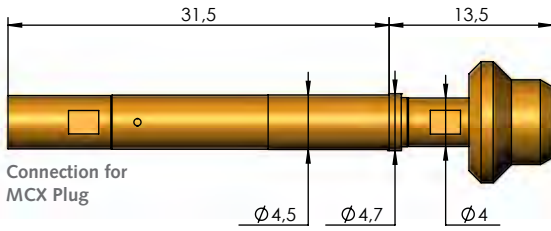

HFS-810 ... M (*)

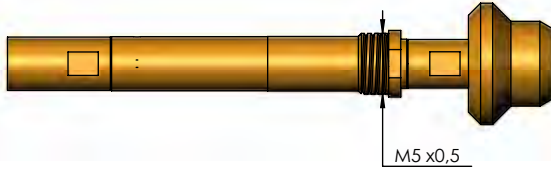

HFS-410 ...

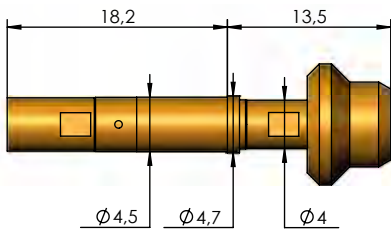

HFS-410 ... M (*)

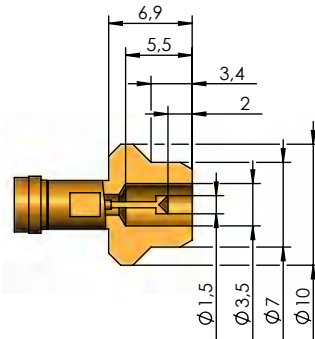
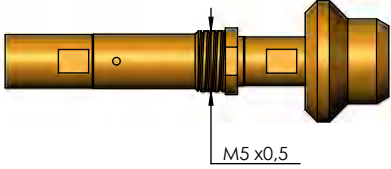

- HFS-810 303 150 A **xx** 42 W
- HFS-810 303 150 A **xx** 42 W M
- HFS-410 303 150 A **xx** 42 W
- HFS-410 303 150 A **xx** 42 W M

Note: Version with pre-centering on the inner side of the Connector Outer Contact. Centering range: ± 0.4 mm

Spring force rating

The spring-loaded Inner and Outer Conductor are available with different spring forces. The ordering description is derived by adding up the individual values.

	HFS-810 HFS-810 M				HFS-410 HFS-410 M
Spring Force of Inner Conductor (N)	1.3	2.0	1.3	2.0	1.0
Spring Force of Outer Conductor (N)	4.0	6.0	8.0	8.0	4.0
Character for ordering	53	80	93	99	50

Note: (*)
For usage in the case of vibration, shaking, snapping or assembly upside down.

Mechanical Data
HFS-810 and HFS-810 M

	Outer Cond.	Inner Cond.
Working Stroke:	4.0 mm	2.0 mm
Maximum Stroke:	5.0 mm	3.7 mm

Mechanical Data
HFS-410 and HFS-410 M

	Outer Cond.	Inner Cond.
Working Stroke:	2.0 mm	2.0 mm
Maximum Stroke:	3.0 mm	3.0 mm

FME Signal Conductor Plug

up to 4 GHz
(50 Ω)

HFS-840 / HFS-840 M
HFS-440 / HFS-440 M

Series:

Available Tip Styles:

Ordering Description:

HFS-840 ...

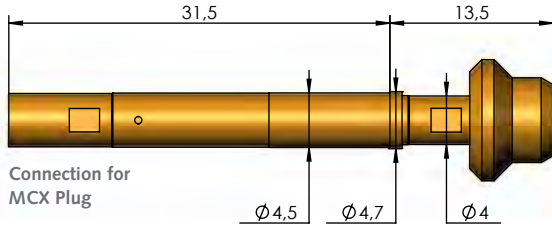

HFS-840 ... M (*)

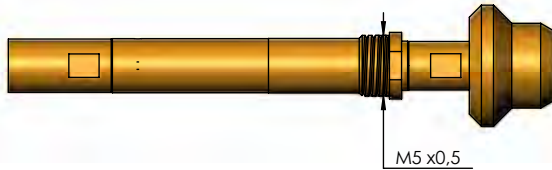

HFS-440 ...

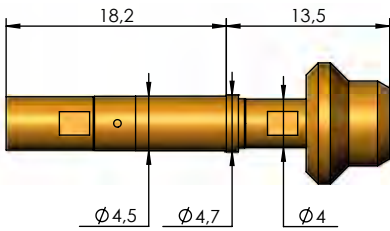

HFS-440 ... M (*)

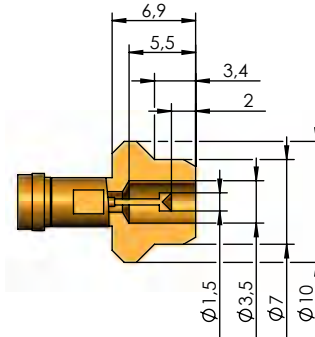
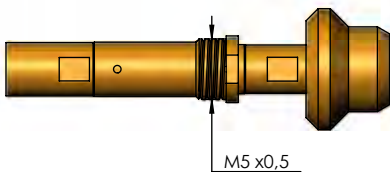

- HFS-840 303 150 A **xx** 42 W
- HFS-840 303 150 A **xx** 42 W M
- HFS-440 303 150 A **xx** 42 W
- HFS-440 303 150 A **xx** 42 W M

Note: Version with pre-centering on the inner side of the Connector Outer Contact. Centering range: ± 0.4 mm

Spring force rating

The spring-loaded Inner and Outer Conductor are available with different spring forces. The ordering description is derived by adding up the individual values.

	HFS-840 HFS-840 M				HFS-440 HFS-440 M
Spring Force of Inner Conductor (N)	1.3	2.0	1.3	2.0	1.0
Spring Force of Outer Conductor (N)	4.0	6.0	8.0	8.0	4.0
Character for ordering	53	80	93	99	50

Note: (*)

For usage in the case of vibration, shaking, snapping or assembly upside down.

Mechanical Data

HFS-840 and HFS-840 M

	Outer Cond.	Inner Cond.
Working Stroke:	4.0 mm	2.0 mm
Maximum Stroke:	5.0 mm	3.7 mm

Mechanical Data

HFS-440 and HFS-440 M

	Outer Cond.	Inner Cond.
Working Stroke:	2.0 mm	2.0 mm
Maximum Stroke:	3.0 mm	3.0 mm

MMBX / MMCP / MMPPX / MCB / MCK
SMB / SMC
SMP (X/MAX) / SMP-L / SSMP / P-SMP
SMA / PC3.5 QMA
BMA / BNC 1.0/2.3
N / FME / 7/16
U.FL / W.FL / W.FL2 / X.FL / MM5829
Reverse SMA / TNC
IEC / F (75 Ω)
FAKRA / GT13 / GT16
Digital
Switch connector contacting
PCB test point
PCB test point side
Coaxial dipole probe
Accessories

Series:

Available Tip Styles:

Ordering Description:

HFS-864 ...

HFS-864 342 700 A **xxx** 43 F716

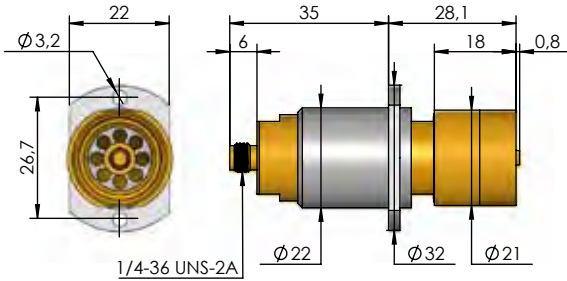

Connection for SMA Plug

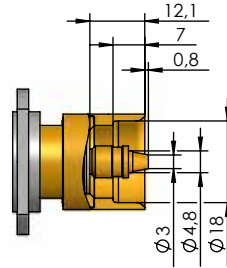

Note: Version with flange connection.
Centering range: ± 1.0 mm

	HFS-864
Spring Force of Inner Conductor (N)	5.0
Spring Force of Outer Conductor (N)	23.6
Character for ordering	286

Mechanical Data

HFS-864

	Outer Cond.	Inner Cond.
Working Stroke:	4.0 mm	2.0 mm
Maximum Stroke:	5.0 mm	4.0 mm

Note:
The RF test probes in the HFS-864 series are positioned and fixed with two screws using a flange connection.

For usage in the case of vibration, shaking, snapping or assembly upside down.

The Test Fixtures Catalog

Our new Test Fixtures Catalog presents not only manual, pneumatic and vacuum-operated Test Fixtures, but also especially a choice of customized Test Fixtures. Based on the proven and remarkable solutions you will get an impression of our many years of experience in customized Test Fixture design and manufacturing as well as the flexibility and know-how of INGUN.



*Ask for our Test Fixtures Catalog or
take a look on our Internet homepage
www.ingun.com*

Contacting of U.FL Connectors

Series U.FL

Connection Dimensions

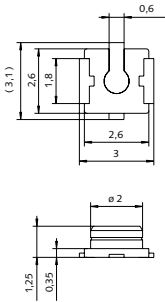

Example:
U.FL Signal Conductor Plug



Contacting of W.FL Connectors

Series W.FL

Connection Dimensions

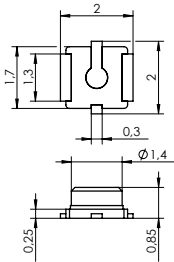

Example:
W.FL Signal Conductor Plug



Contacting of W.FL2 Connectors

Series W.FL 2

Connection Dimensions

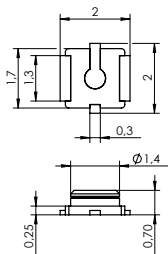

Example:
W.FL 2 Signal Conductor Plug



Contents

U.FL

Signal Conductor Plug

2 GHz	90
HFS-810, HFS-810 M	
HFS-410, HFS-410 M	
4 GHz	91
HFS-840, HFS-840 M	
HFS-440, HFS-440 M	
6 GHz	92 - 95
HFS-860, HFS-860 M	
HFS-822	
HFS-852	
HFS-856	

W.FL

Signal Conductor Plug

6 GHz	96 - 97
HFS-860, HFS-860 M	
HFS-856	

W.FL2

Signal Conductor Plug

6 GHz	96 - 97
HFS-860, HFS-860 M	
HFS-856	

X.FL s. page 96 - 97

MM5829

s. page 98

Receptacles (KS)	192 - 194
------------------	-----------

Spacer of Receptacles (DS)	195
----------------------------	-----

Cable plug assembly (SE)	196 - 199
--------------------------	-----------

Tools	200 - 201
-------	-----------

Inner Conductor/Signal Conductor	202 - 204
----------------------------------	-----------

X.FL

Signal Conductor Plug

6 GHz 96 - 97
 HFS-860, HFS-860 M
 HFS-856

MM5829

Signal Conductor Plug

6 GHz 98
 HFS-822

Receptacles (KS) 192 - 194

Spacer of Receptacles (DS) 195

Cable plug assembly (SE) 196 - 199

Tools 200 - 201

Inner Conductor/Signal Conductor 202 - 204

Contacting of X.FL Connectors

Series X.FL

Connection Dimensions

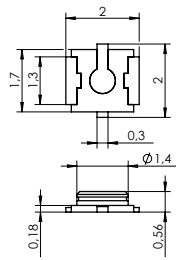

Example:

X.FL Signal Conductor Plug



Contacting of MM5829 Connectors

Series MM5829

Connection Dimensions

Signal Conductor Plug

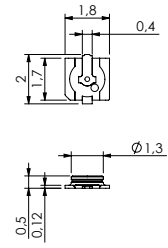

Example:

MM5829 Signal Conductor Plug



U.FL / W.FL / W.FL2 / X.FL / MM5829 Connectors

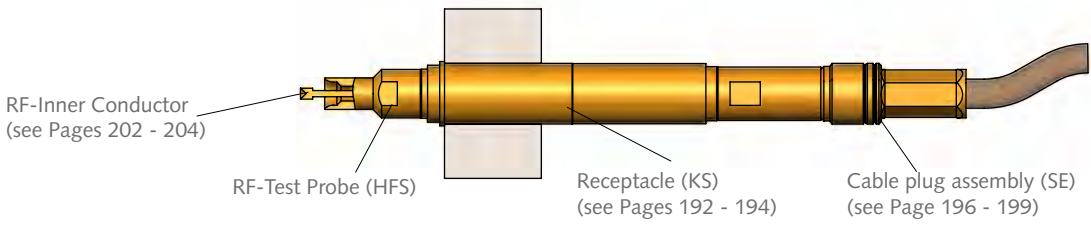

Contacting Example U.FL:

Contacting of U.FL Signal Conductor Plug
HFS-810 303 090 A 5343 Y6

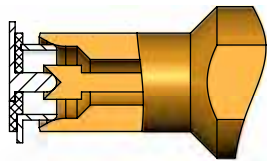

Customizing Example:

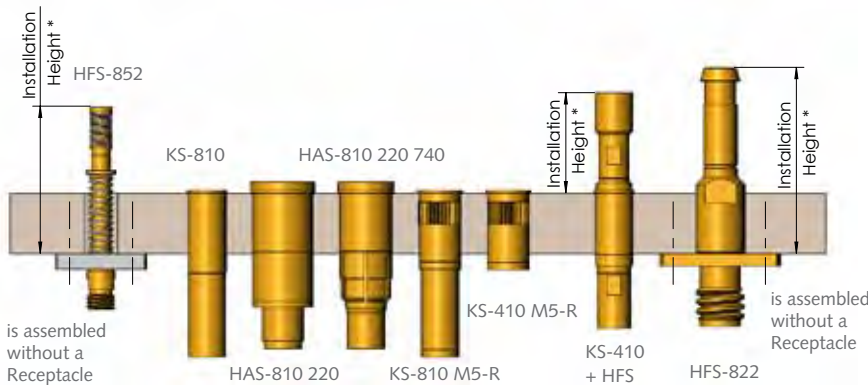

Electrical Data

HFS-810 / 810 M	HFS-840 / 840 M
HFS-410 / 410 M	HFS-440 / 440 M
HFS-822	HFS-852
HFS-856	HFS-860 / 860 M

Frequency Range with HFS-810/410:	up to 2 GHz
Frequency Range with HFS-840/440:	up to 4 GHz
Frequency Range with HFS-822/852:	up to 6 GHz
Frequency Range with HFS-856/860:	up to 6 GHz
Current Rating Outer Conductor:	8–10 A
Current Rating Inner Conductor:	2–3 A
R_i typical Inner Conductor:	≤ 10 mΩ
Impedance Test Probe:	50 Ω
Impedance Cable:	50 Ω

Operating Temperature Range

–40 up to +80° C

Installation Height in Receptacle		KS-810 (F) KS-410 (F) KS-810 M5-(R/F) KS-410 M5-(R/F)	HAS-810 220 (F) HAS-810 220 740 (F)	without KS
Variant		*Installation Height HFS in KS		
U.FL Signal Conductor Plug	...Y6 / ...Y6 M	11.9 mm	13 mm	---
	(HFS-822)	---	---	27.0 mm
	(HFS-852)	---	---	19.5 mm
	(HFS-856)	---	---	22.4 mm
W.FL Signal Conductor Plug	... Y52	9.8 mm	10.9 mm	---
	... XFL	---	---	22.6 mm
W.FL 2 Signal Conductor Plug	... Y52	9.8 mm	10.9 mm	---
	... XFL	---	---	22.6 mm
X.FL Signal Conductor Plug	... Y52	9.8 mm	10.9 mm	---
	... XFL	---	---	22.6 mm
MM5829-Signal Conductor Plug	... MM5829	---	---	23.1 mm

Note:

Further details of receptacles with and without flange connection (F) see pages 192 - 194.

FME Signal Conductor Plug

up to 2 GHz
(50 Ω)

HFS-810 / HFS-810 M
HFS-410 / HFS-410 M

Series:

Available Tip Styles:

Ordering Description:

HFS-810 ...

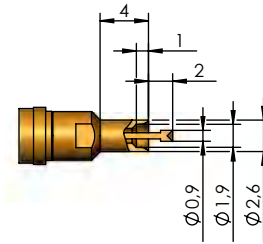
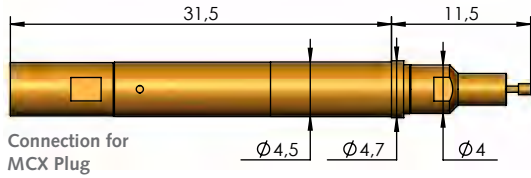

HFS-810 303 090 A **xx** 43 Y6
HFS-810 303 090 A **xx** 43 Y6 M
HFS-410 303 090 A **xx** 43 Y6
HFS-410 303 090 A **xx** 43 Y6 M

Note:
Centering range: ± 0.2 mm

HFS-810 ... M (*)

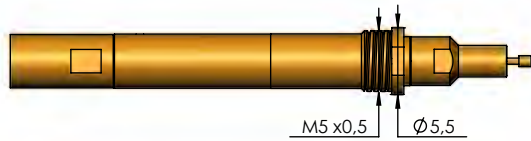

HFS-410 ...

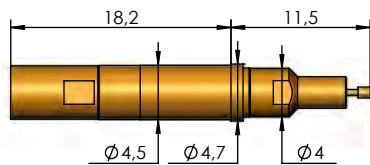

HFS-410 ... M (*)

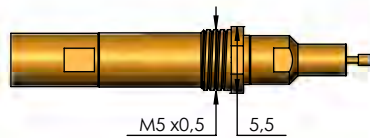

Spring force rating

The spring-loaded Inner and Outer Conductor are available with different spring forces. The ordering description is derived by adding up the individual values.

	HFS-810 HFS-810 M				HFS-410 HFS-410 M
Spring Force of Inner Conductor (N)	1.3	2.0	1.3	2.0	1.0
Spring Force of Outer Conductor (N)	4.0	6.0	8.0	8.0	4.0
Character for ordering	53	80	93	99	50

Note: (*)

For usage in the case of vibration, shaking, snapping or assembly upside down.

Mechanical Data

HFS-810 and HFS-810 M

	Outer Cond.	Inner Cond.
Working Stroke:	4.0 mm	2.0 mm
Maximum Stroke:	5.0 mm	3.7 mm

Mechanical Data

HFS-410 and HFS-410 M

	Outer Cond.	Inner Cond.
Working Stroke:	2.0 mm	2.0 mm
Maximum Stroke:	3.0 mm	3.0 mm

Series:

Available Tip Styles:

Ordering Description:

HFS-840 ...

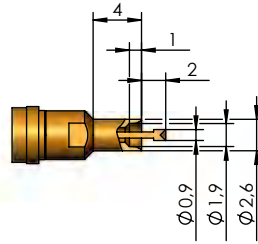
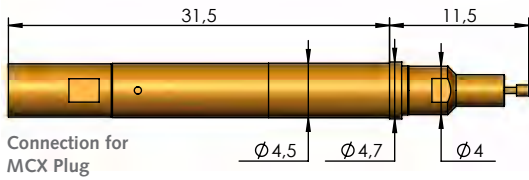

- HFS-840 303 090 A **xx** 43 Y6
- HFS-840 303 090 A **xx** 43 Y6 M
- HFS-440 303 090 A **xx** 43 Y6
- HFS-440 303 090 A **xx** 43 Y6 M

Note:
Centering range: ± 0.2 mm

HFS-840 ... M (*)

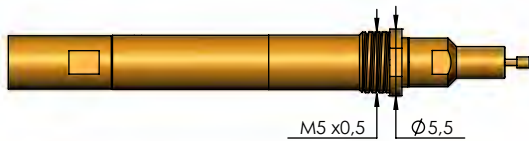

HFS-440 ...

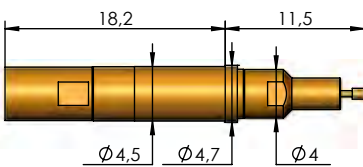

HFS-440 ... M (*)

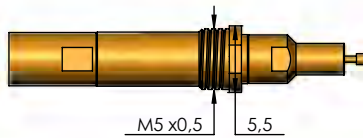

Spring force rating

The spring-loaded Inner and Outer Conductor are available with different spring forces. The ordering description is derived by adding up the individual values.

	HFS-840 HFS-840 M				HFS-440 HFS-440 M
Spring Force of Inner Conductor (N)	1.3	2.0	1.3	2.0	1.0
Spring Force of Outer Conductor (N)	4.0	6.0	8.0	8.0	4.0
Character for ordering	53	80	93	99	50

Note: (*)

For usage in the case of vibration, shaking, snapping or assembly upside down.

Mechanical Data

HFS-840 and HFS-840 M

	Outer Cond.	Inner Cond.
Working Stroke:	4.0 mm	2.0 mm
Maximum Stroke:	5.0 mm	3.7 mm

Mechanical Data

HFS-440 and HFS-440 M

	Outer Cond.	Inner Cond.
Working Stroke:	2.0 mm	2.0 mm
Maximum Stroke:	3.0 mm	3.0 mm

U.FL Signal Conductor Plug

up to 6 GHz
(50 Ω)

HFS-860 / HFS-860 M

Series:

Available
Tip Styles:

Ordering Description:

HFS-860 ...

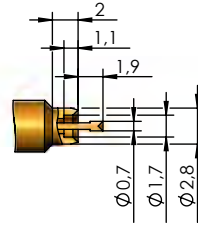
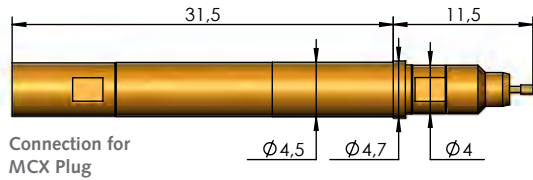

HFS-860 303 074 A **xx** 43 Y6
HFS-860 303 074 A **xx** 43 Y6 M

Note:
Centering range: ± 0.2 mm

HFS-860 ... M (*)

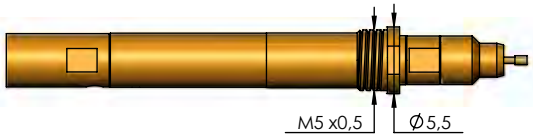

Spring force rating

The spring-loaded Inner and Outer Conductor are available with different spring forces. The ordering description is derived by adding up the individual values.

	HFS-860 HFS-860 M			
	1.3	2.0	1.3	2.0
Spring Force of Inner Conductor (N)	1.3	2.0	1.3	2.0
Spring Force of Outer Conductor (N)	4.0	6.0	8.0	8.0
Character for ordering	53	80	93	99

Note: (*)

For usage in the case of vibration, shaking, snapping or assembly upside down.

Mechanical Data

HFS-860 and HFS-860 M

	Outer Cond.	Inner Cond.
Working Stroke:	4.0 mm	2.0 mm
Maximum Stroke	5.0 mm	3.7 mm

Series:

Available Tip Styles:

Ordering Description:

HFS-822 ...

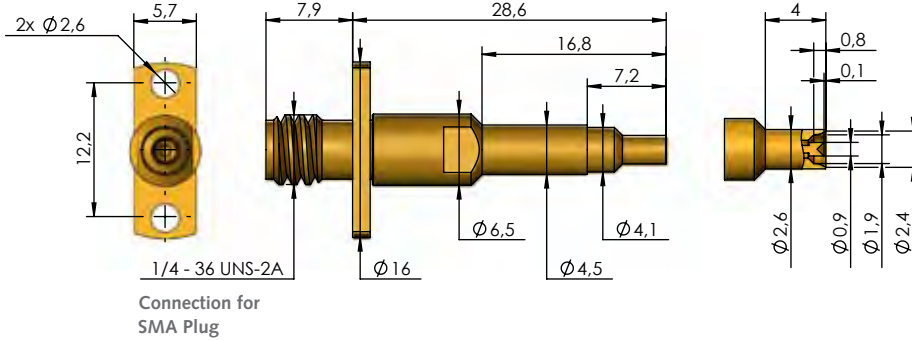

HFS-822 303 090 A **xx** 43 UFL

Note: Version with flange connection. No movement of the connection during stroke movement.
Centering range: ± 0.2 mm

Spring force rating

The spring-loaded Inner and Outer Conductor are available with different spring forces. The ordering description is derived by adding up the individual values.

Note:
The RF test probes in the HFS-822 series are positioned and fixed with two screws using a flange connection.

For usage in the case of vibration, shaking, snapping or assembly upside down.

	HFS-822
Spring Force of Inner Conductor (N)	1.0
Spring Force of Outer Conductor (N)	4.0
Character for ordering	50

Mechanical Data

HFS-822

	Outer Cond.	Inner Cond.
Working Stroke:	4.0 mm	4.0 mm
Maximum Stroke	4.5 mm	4.5 mm

U.FL Signal Conductor Plug

up to 6 GHz
(50 Ω)

HFS-852

Series:



Available Tip Styles:

Ordering Description:

HFS-852 ...

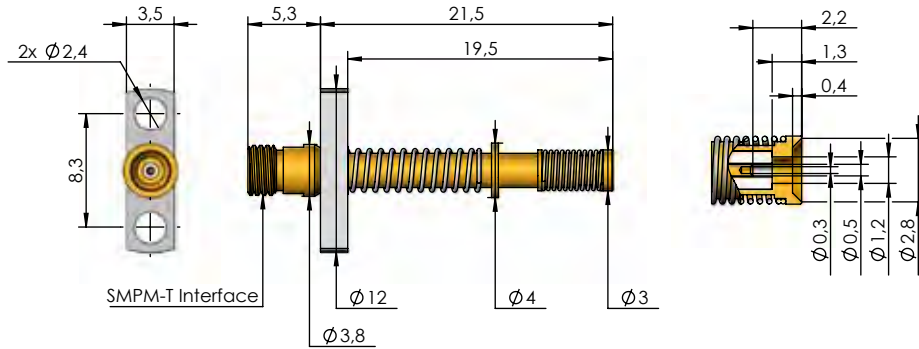

HFS-852 303 051 A **xx** 43 UFL

Note: The HFS-852 is float-mounted and moves out during the working stroke movement. Compensation of radial positioning inaccuracies of the connector by up to $\pm 2,0^\circ$.
Centering range: ± 0.3 mm

Note:

The RF test probes in the HFS-852 series are positioned and fixed with two screws using a flange connection.

For usage in the case of vibration, shaking, snapping or assembly upside down.

	HFS-852
Spring Force of Inner Conductor (N)	1.0
Spring Force of Outer Conductor (N)	3.0
Character for ordering	40

Mechanical Data

HFS-852

	Outer Cond.	Inner Cond.
Working Stroke:	3.7 mm	1.0 mm
Maximum Stroke	4.7 mm	1.5 mm

MMBX / MMCP / MMPPX / MMBX / MMCK
SMB / SMC
SMP (X/)/MAX / SMP-L / SSMP / P-5MP
SMA / PC3.5 / QMA
BMA / BNC / 1.0/2.3
N / FME / 7/16
U.FL / W.FL / W.FL2 / X.FL / MM5829
Reverse SMA / TNC
IEC / F (75 Ω)
FAKRA / GT13 / GT16
Digital
Switch connector contacting
PCB test point
PCB test point side
Coaxial dipole probe
Accessories

Series:



Available Tip Styles:

Ordering Description:

HFS-856 ...

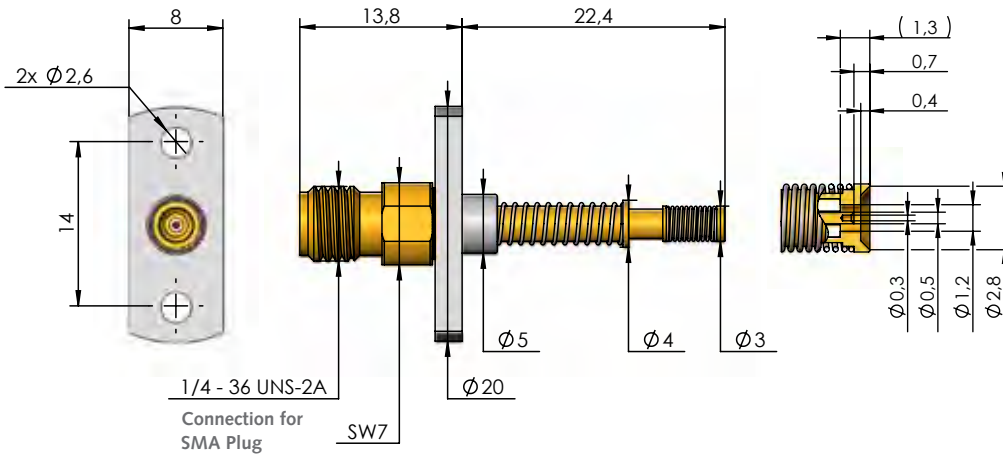

HFS-856 303 051 A **xx** 43 UFL

Note: The HFS-856 is float-mounted and the connection moves out during the working stroke movement. Compensation of radial positioning inaccuracies of the connector by up to ± 3,0°. Centering range: ± 0.3 mm

Note:
The RF test probes in the HFS-856 series are positioned and fixed with two screws using a flange connection.
For usage in the case of vibration, shaking, snapping or assembly upside down.

	HFS-856
Spring Force of Inner Conductor (N)	1.5
Spring Force of Outer Conductor (N)	4.0
Character for ordering	55

Mechanical Data

HFS-856

	Outer Cond.	Inner Cond.
Working Stroke:	4.2 mm	1.0 mm
Maximum Stroke	5.2 mm	2.0 mm

W.FL / W.FL2 / X.FL Signal Conductor Plug

up to 6 GHz
(50 Ω)

HFS-860 / HFS-860 M

Series:

Available
Tip Styles:

Ordering Description:

HFS-860 ...

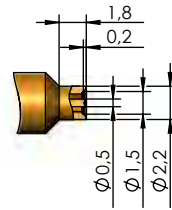
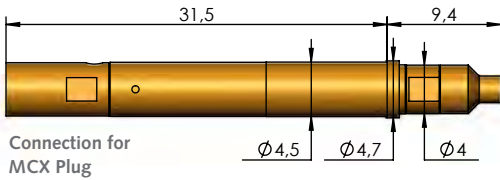

HFS-860 353 051 A **xx** 43 Y52
HFS-860 353 051 A **xx** 43 Y52 M

Note:
Centering range: ± 0.3 mm

HFS-860 ... M (*)

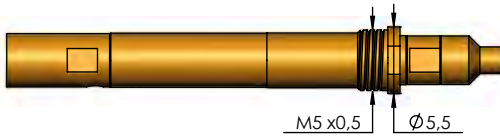

Spring force rating

The spring-loaded Inner and Outer Conductor are available with different spring forces. The ordering description is derived by adding up the individual values.

	HFS-860 HFS-860 M			
	1.3	2.0	1.3	2.0
Spring Force of Inner Conductor (N)	1.3	2.0	1.3	2.0
Spring Force of Outer Conductor (N)	4.0	6.0	8.0	8.0
Character for ordering	53	80	93	99

Note: (*)

For usage in the case of vibration, shaking, snapping or assembly upside down.

Mechanical Data

HFS-860 and HFS-860 M

	Outer Cond.	Inner Cond.
Working Stroke:	4.0 mm	0.2 mm
Maximum Stroke:	5.0 mm	2.8 mm

Series:



Available
Tip Styles:

Ordering Description:

HFS-856 ...

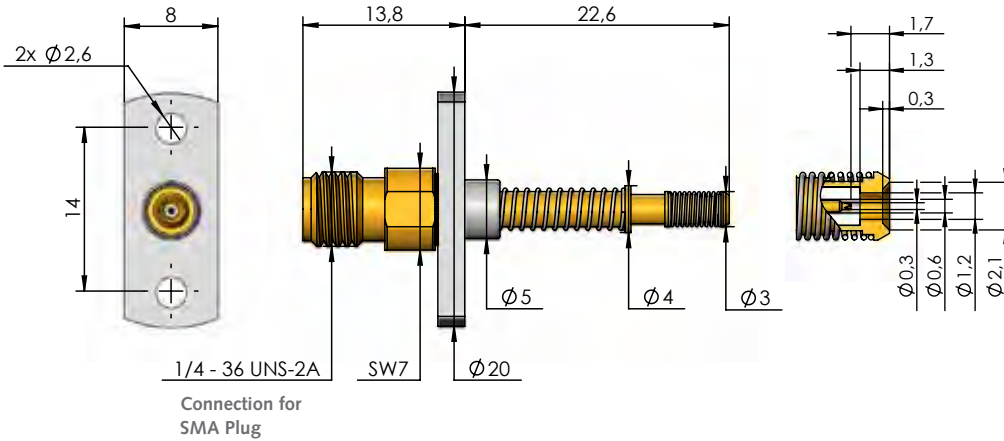

HFS-856 379 030 A **xx** 43 XFL

Note: The HFS-856 is float-mounted and the connection moves out during the working stroke movement. Compensation of radial positioning inaccuracies of the connector by up to ± 3,0°. Centering range: ± 0.3 mm

Note:
The RF test probes in the HFS-856 series are positioned and fixed with two screws using a flange connection.

For usage in the case of vibration, shaking, snapping or assembly upside down.

	HFS-856
Spring Force of Inner Conductor (N)	1.5
Spring Force of Outer Conductor (N)	4.0
Character for ordering	55

Mechanical Data

HFS-856

	Outer Cond.	Inner Cond.
Working Stroke:	4.2 mm	1.0 mm
Maximum Stroke:	5.2 mm	2.0 mm

MMBX / MMCP / MMPPX / MCB / MCK
SMB / SMC
SMP (X/MAX) / SMP-L / SSMP / P-SMP
SMA / PC3.5 / QMA
BMA / BNC / 1.0/2.3
N / FME / 7/16
U.FL / W.FL / W.FL2 / X.FL / MM5829
Reverse SMA / TNC
IEC / F (75 Ω)
FAKRA / GT13 / GT16
Digital
Switch connector contacting
PCB test point
PCB test point side
Coaxial dipole probe
Accessories

MM5829 Signal Conductor Plug

up to 6 GHz
(50 Ω)

HFS-822

Series:

Available
Tip Styles:

Ordering Description:

HFS-822 ...

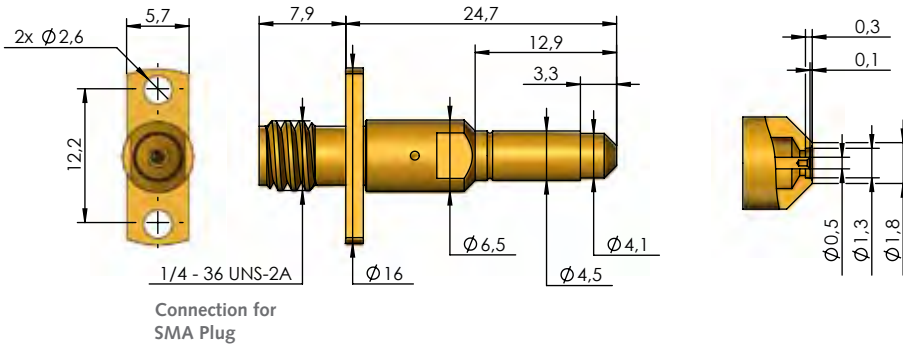

HFS-822 303 090 A **xx** 43 MM5829

Note: Version with flange connection. No movement of the connection during stroke movement.
Centering range: ± 0.1 mm

Spring force rating

The spring-loaded Inner and Outer Conductor are available with different spring forces. The ordering description is derived by adding up the individual values.

Note:

The RF test probes in the HFS-822 series are positioned and fixed with two screws using a flange connection.

For usage in the case of vibration, shaking, snapping or assembly upside down.

	HFS-822
Spring Force of Inner Conductor (N)	1.0
Spring Force of Outer Conductor (N)	4.0
Character for ordering	50

Mechanical Data

HFS-822

	Outer Cond.	Inner Cond.
Working Stroke:	2.0 mm	2.0 mm
Maximum Stroke:	2.4 mm	2.4 mm

Contacting of R-SMA Reverse Polarity Connectors

Series R-SMA

Connection Dimensions
Signal Conductor Plug

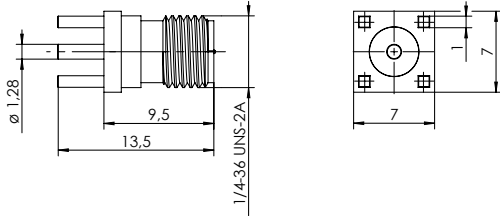

Example:

R-SMA Signal Conductor Plug



Contacting of R-TNC Reverse Polarity Connectors

Series R-TNC

Connection Dimensions
Signal Conductor Plug

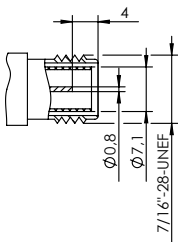

Example:

R-TNC Signal Conductor Plug



All specifications are subject to change without prior notification

Contents

R-SMA

Signal Conductor Plug

6 GHz 101
HFS-860, HFS-860 M

R-TNC

Signal Conductor Plug

2 GHz 102
HFS-810, HFS-810 M
HFS-410, HFS-410 M

4 GHz 103
HFS-840, HFS-840 M
HFS-440, HFS-440 M

Receptacles (KS) 192 - 194

Spacer of Receptacles (DS) 195

Cable plug assembly (SE) 196 - 199

Tools 200 - 201

Inner Conductor/
Signal Conductor 202 - 204

MMBX /
MMCK / MMPC
MBX / MCK

SMB / SMC

SMP (X/MAX) /
SMP-L 5SMP /
P-5MP

SMA / PC3.5
QMA

BMA / BNC
1.0/2.3

N / FME /
7/16

U.FL / W.FL /
W.FL2 / X.FL /
MM5829

Reverse
SMA / TNC

IEC /
F (75 Ω)

FAKRA /
GT13 / GT16

Digital

Switch
connector
contacting

PCB
test point

PCB test
point side

Coaxial
dipole probe

Accessories

R-SMA / R-TNC Reverse Polarity Connectors

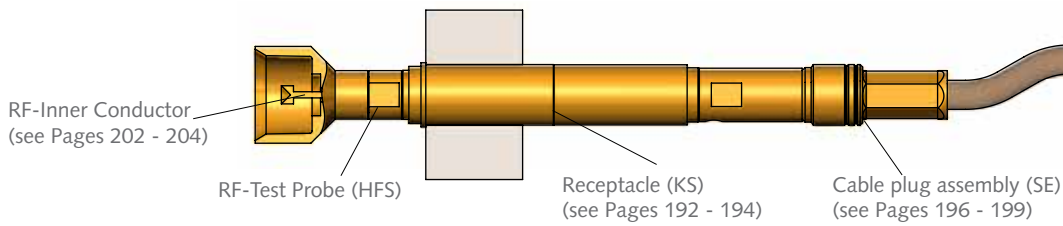

Contacting Example R-SMA:

Contacting of R-SMA Signal Conductor Plug

HFS-860 303 150 A 5343 ER

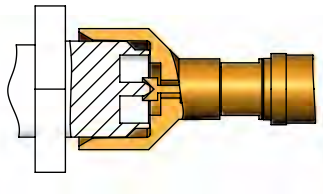

Customizing Example:

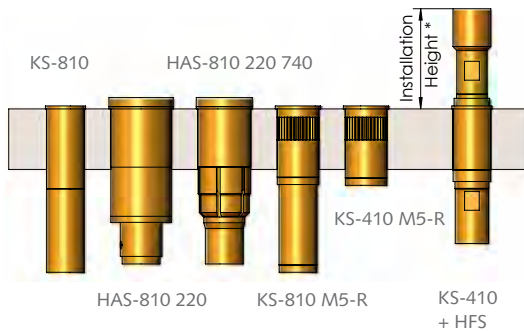

Installation Height in Receptacle		KS-810 (F) KS-410 (F) KS-810 M5-(R/F) KS-410 M5-(R/F)	HAS-810 220 (F) HAS-810 220 740 (F)
Variant		*Installation Height HFS in KS	
R-SMA Signal Conductor Plug	... ER / ... ER M	14.1 mm	15.2 mm
R-TNC Signal Conductor Plug	... QN / ... QN M	12.4 mm	13.5 mm

Electrical Data

HFS-810 / 810 M HFS-840 / 840 M

HFS-410 / 410 M HFS-440 / 440 M

HFS-860 / 860 M

Frequency Range with HFS-810/410: bis 2 GHz

Frequency Range with HFS-840/440: bis 4 GHz

Frequency Range with HFS-860: bis 6 GHz

Current Rating Outer Conductor: 8–10 A

Current Rating Inner Conductor: 2–3 A

R_i typical Inner Conductor ≤ 10 mΩ

Impedance Test Probe: 50 Ω

Impedance Cable 50 Ω

Operating Temperature Range

–40 up to +80° C

Note:

Further details of receptacles with and without flange connection (F) see pages 192 - 194.

Series:

Available Tip Styles:

Ordering Description:

HFS-860 ...

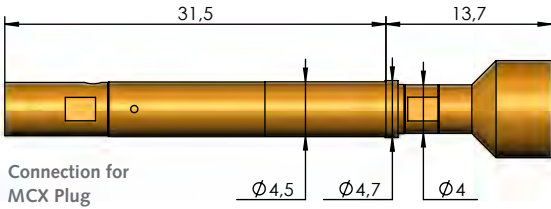

Connection for MCX Plug

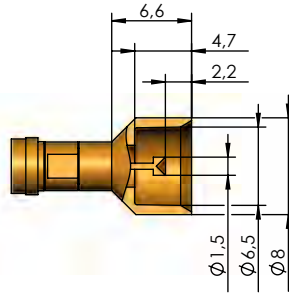

HFS-860 303 150 A **xx** 43 ER
HFS-860 303 150 A **xx** 43 ER M

Note: Version with pre-centering via Outer Plunger. Outer plunger centers itself from the outer side on the Connector. Centering range: ± 1.0 mm

HFS-860 ... M (*)



Spring force rating

The spring-loaded Inner and Outer Conductor are available with different spring forces. The ordering description is derived by adding up the individual values.

	HFS-860 HFS-860 M			
Spring Force of Inner Conductor (N)	1.3	2.0	1.3	2.0
Spring Force of Outer Conductor (N)	4.0	6.0	8.0	8.0
Character for ordering	53	80	93	99

Mechanical Data

HFS-860 and HFS-860 M

	Outer Cond.	Inner Cond.
Working Stroke:	4.0 mm	2.0 mm
Maximum Stroke:	5.0 mm	3.7 mm

Note: (*)
For usage in the case of vibration, shaking, snapping or assembly upside down.

R-TNC Signal Conductor Plug

up to 2 GHz
(50 Ω)

HFS-810 / HFS-810 M
HFS-410 / HFS-410 M

Series:

Available Tip Styles:

Ordering Description:

HFS-810 ...

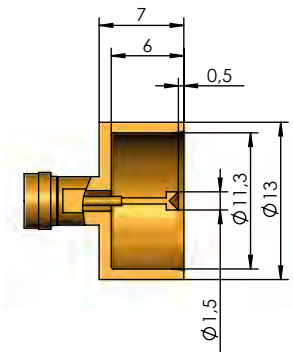
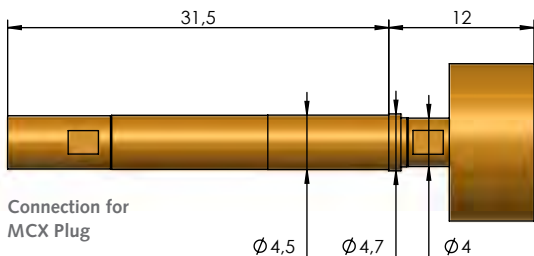

HFS-810 303 150 A **xx** 43 QN
HFS-810 303 150 A **xx** 43 QN M
HFS-410 303 150 A **xx** 43 QN
HFS-410 303 150 A **xx** 43 QN M

Note: Version with pre-centering via Outer Plunger. Outer plunger centers itself from the outer side on the Connector.
Centering range: ± 0.8 mm

HFS-810 ... M (*)

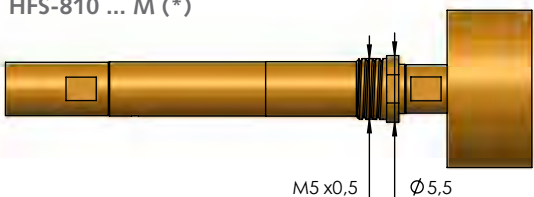

HFS-410 ...

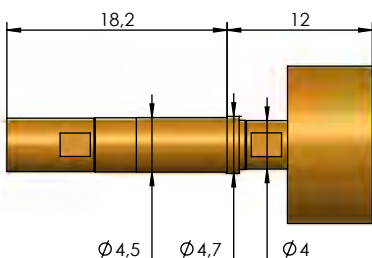

HFS-410 ... M (*)

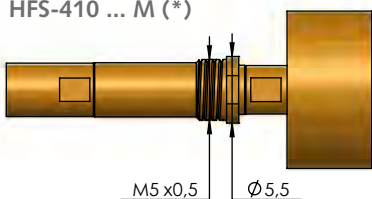

Spring force rating

The spring-loaded Inner and Outer Conductor are available with different spring forces. The ordering description is derived by adding up the individual values.

	HFS-810 HFS-810 M				HFS-410 HFS-410 M
Spring Force of Inner Conductor (N)	1.3	2.0	1.3	2.0	1.0
Spring Force of Outer Conductor (N)	4.0	6.0	8.0	8.0	4.0
Character for ordering	53	80	93	99	50

Note: (*)

For usage in the case of vibration, shaking, snapping or assembly upside down.

Mechanical Data

HFS-810 and HFS-810 M

	Outer Cond.	Inner Cond.
Working Stroke:	4.0 mm	2.0 mm
Maximum Stroke:	5.0 mm	3.7 mm

Mechanical Data

HFS-410 and HFS-410 M

	Outer Cond.	Inner Cond.
Working Stroke:	2.0 mm	2.0 mm
Maximum Stroke:	3.0 mm	3.0 mm

Series:

Available Tip Styles:

Ordering Description:

HFS-840 ...

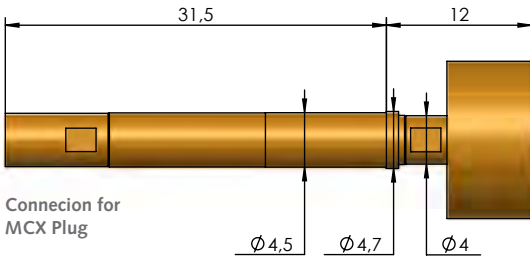

HFS-840 ... M (*)

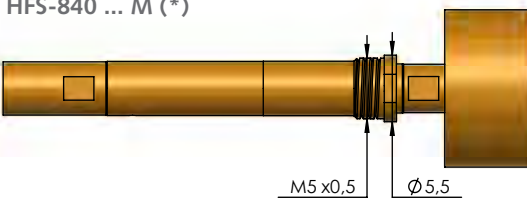

HFS-440 ...

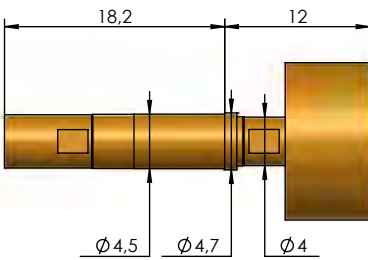

HFS-440 ... M (*)

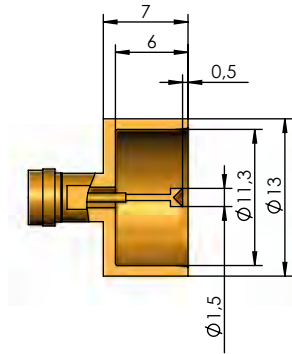
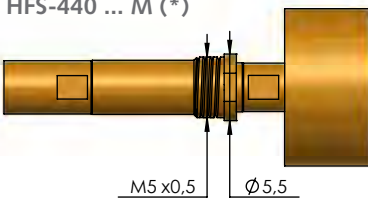

- HFS-840 303 150 A **xx** 43 QN
- HFS-840 303 150 A **xx** 43 QN M
- HFS-440 303 150 A **xx** 43 QN
- HFS-440 303 150 A **xx** 43 QN M

Note: Version with pre-centering via Outer Plunger. Outer plunger centers itself from the outer side on the Connector. Centering range: ± 0.8 mm

Spring force rating

The spring-loaded Inner and Outer Conductor are available with different spring forces. The ordering description is derived by adding up the individual values.

	HFS-840 HFS-840 M				HFS-440 HFS-440 M
Spring Force of Inner Conductor (N)	1.3	2.0	1.3	2.0	1.0
Spring Force of Outer Conductor (N)	4.0	6.0	8.0	8.0	4.0
Character for ordering	53	80	93	99	50

Note: (*)
For usage in the case of vibration, shaking, snapping or assembly upside down.

Mechanical Data
HFS-840 and HFS-840 M

	Outer Cond.	Inner Cond.
Working Stroke:	4.0 mm	2.0 mm
Maximum Stroke:	5.0 mm	3.7 mm

Mechanical Data
HFS-440 and HFS-440 M

	Outer Cond.	Inner Cond.
Working Stroke:	2.0 mm	2.0 mm
Maximum Stroke:	3.0 mm	3.0 mm

INGUN Radio Frequency Test Fixtures

The INGUN radio frequency Test Fixtures are developed and manufactured in accordance to customer demands. They allow testing of highly sensitive PC-Boards without electro-magnetic noise influences.

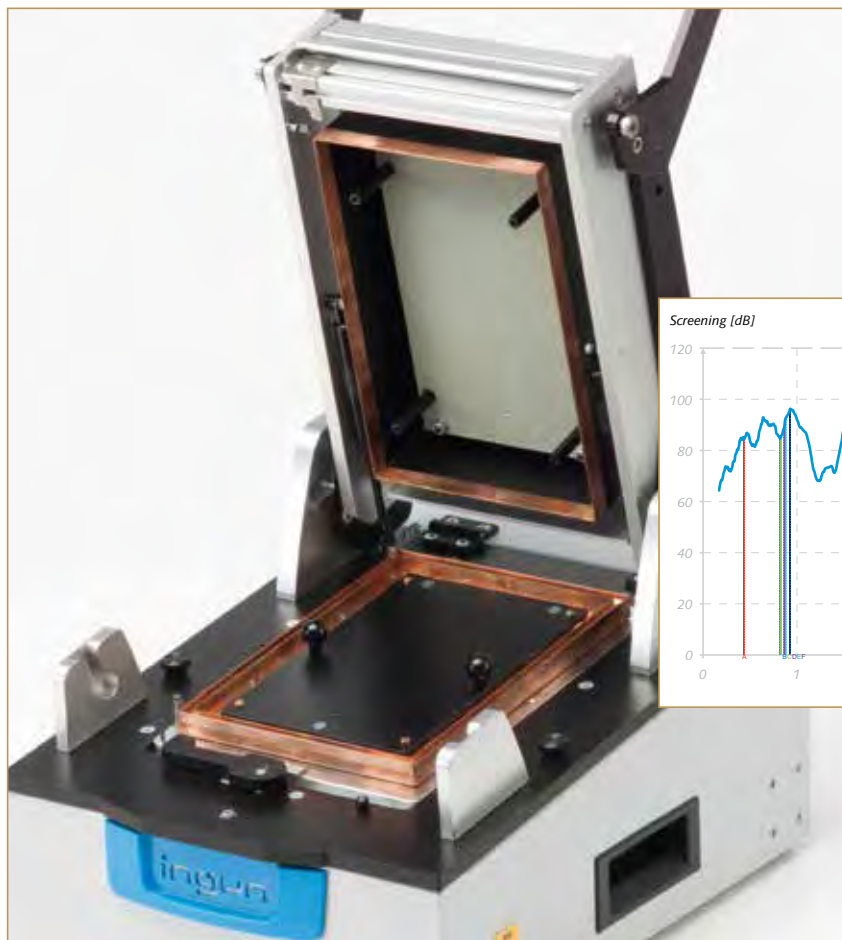

Radio frequency Test Fixture based on MA 2111 with ATS 2111/HF

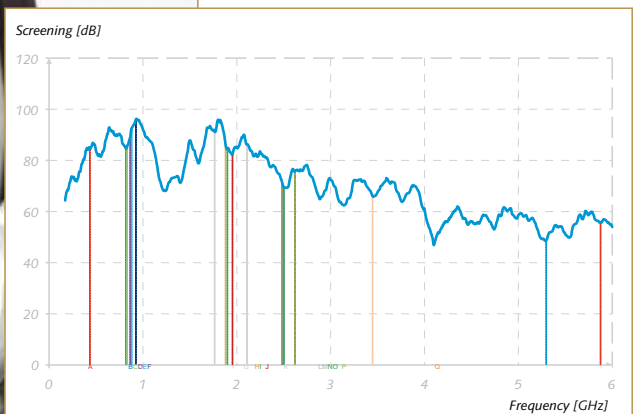

Screening attenuation in the RF range of up to 6 GHz

The UUT is completely shielded to the outside; both for the measurement as well as to protect the operator. Because the attenuation values determine the volume of the test chamber, then these must be known to enable design and manufacturing of the RF Fixture.

The signals, which must be measured on the PC-Board, are passed from the inside through the RF cover to the outside via INGUN RF probes and then on to the Test System.

More details about RF Test Fixtures can be found in our Test Fixtures Catalog – or simply call us!

Contacting of IEC Connectors

Series IEC

Connection Dimensions
Signal Conductor Plug

Signal Conductor Jack

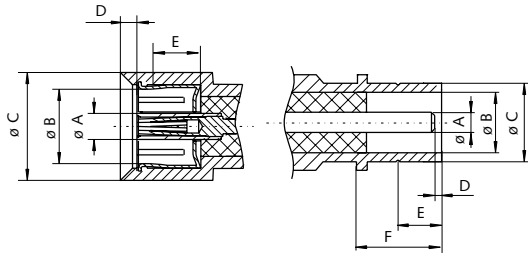

IEC (75 Ohm)				
	Signal Conductor Plug		Signal Conductor Jack	
	min.	max.	min.	max.
A	2.28 / .089	2.42 / .095		1)
B	8.05 / .317			1)
C	9.52 / .375	9.54 / .376	13.0 / .512	nom.
D	0.40 / .016	1.20 / .047	2.2 / .087	nom.
E	4.95 / .195	5.05 / 1.99	6.40 / .252	6.80 / .268
F	9,10 / .358			

1) resilient, dim. to meet electrical and mechanical requirements

Examples:

IEC Signal Conductor Plug

IEC Signal Conductor Jack



Contacting of F Connectors

Series F

Connection Dimension
Signal Conductor Jack

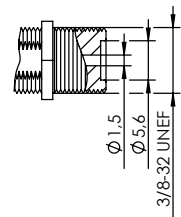

Example:

F Signal Conductor Jack



All specifications are subject to change without prior notification

Contents

IEC

Signal Conductor Plug

1,5 GHz
HFS-409 107

Signal Conductor Jack

1,5 GHz
HFS-409 107

F

Signal Conductor Jack

1,5 GHz
HFS-409 108

Receptacles (KS) 192 - 194

Spacer of Receptacles (DS) 195

Cable plug assembly (SE) 196 - 199

Tools 200 - 201

Inner Conductor/
Signal Conductor 202 - 204

MMBX / MMCPX
MMCK / MMMPX
MBX / MCK
SMB / SMC
SMP (X/MAX)
SMP-L 55MP / P-5MP
SMA / PC3.5
QMA
BMA / BNC
1,0/2.3
N / FME / 7/16
U.FL / W.FL / W.FL2 / X.FL / MM5829
Reverse SMA / TNC
IEC / F (75 Ω)
FAKRA / GT13 / GT16
Digital
Switch connector contacting
PCB test point
PCB test point side
Coaxial dipole probe
Accessories

IEC, F Connectors

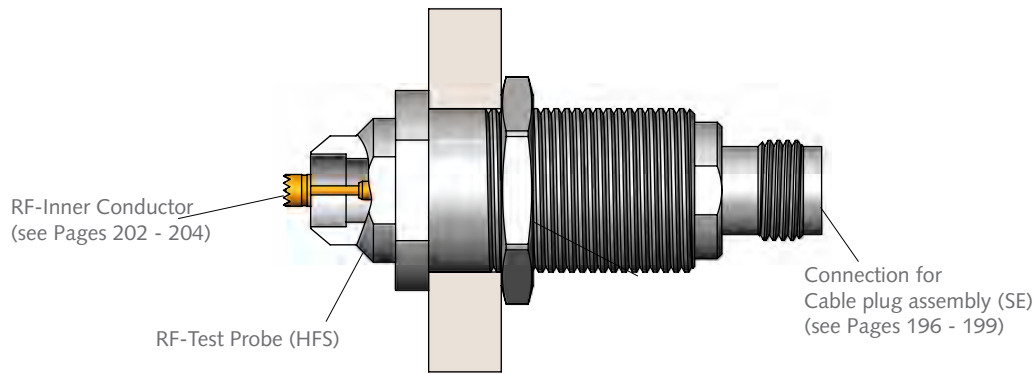

Contacting Example IEC:

Contacting of IEC Signal Conductor Plug
HFS-409 306 350 A 8343 M

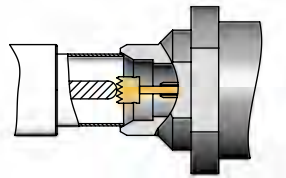

Contacting of IEC Signal Conductor Jack
HFS-409 306 350 A 8342 M

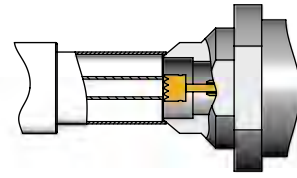

Customizing Example:

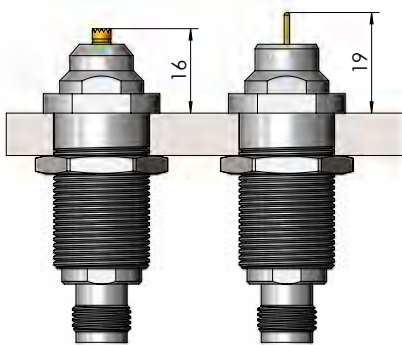

HFS-409 306 350 A 8342 M HFS-409 305 100 A 8343 F MF

Electrical Data

HFS-409

Frequency Range with HFS-409:	up to 1.5 GHz
Current Rating Outer Conductor:	10 A
Current Rating Inner Conductor:	16 A
R _i typical Inner Conductor:	≤ 10 mΩ
Impedance Test Probe:	75 Ω
Impedance Cable:	75 Ω

Operating Temperature Range

-40 up to +80° C

Series: Plug

Available Tip Styles:

Ordering Description:

HFS-409 ...

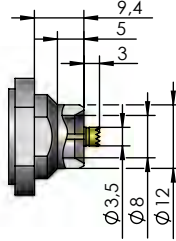
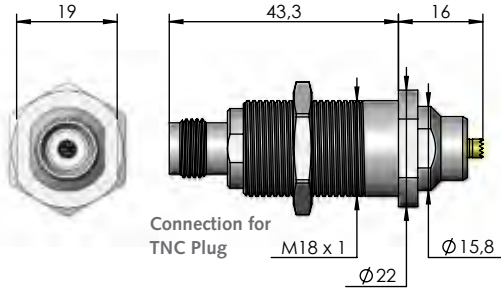

HFS-409 306 350 A **xx** 43 M

Note: Version with outer centering on Connector. No movement of threaded connection during stroke movement. Centering range: ± 0.2 mm

Series: Jack

Available Tip Styles:

Ordering Description:

HFS-409 ...

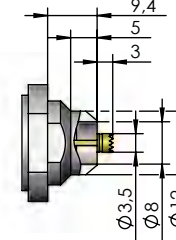
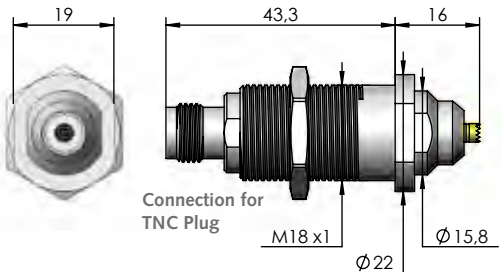

HFS-409 306 350 A **xx** 42 M

Note: Version with centering on the inner side of the Connector Outer Contact. No movement of the threaded connection during stroke movement. Centering range: ± 0.2 mm

	HFS-409
Spring Force of Inner Conductor (N)	2.3
Spring Force of Outer Conductor (N)	6.0
Character for ordering	83

Note:
The RF Probes of the series HFS-409 are secured in a bore (Ø 18.5 mm) by means of an M18x1 thread and a nut.

Mechanical Data		
HFS-409		
	Outer Cond.	Inner Cond.
Working Stroke:	4.0 mm	2.3 mm
Maximum Stroke:	5.0 mm	5.3 mm

◎ F-Signal Conductor Jack

up to 1.5 GHz
(75 Ω)

HFS-409

Series:

Available Tip Styles:

Ordering Description:

HFS-409 ...

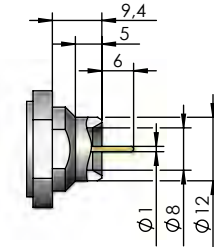
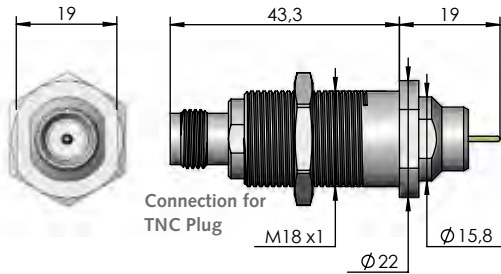

HFS-409 305 100 A **xx** 43 MF

Note: Version with threaded connection. No movement of the connection during stroke movement.
Centering range: ± 0.2 mm

	HFS-409
Spring Force of Inner Conductor (N)	2.3
Spring Force of Outer Conductor (N)	6.0
Character for ordering	83

Note:

The RF Probes of the series HFS-409 are secured in a bore (Ø 18.5 mm) by means of an M18x1 thread and a nut.

Mechanical Data

HFS-409

	Outer Cond.	Inner Cond.
Working Stroke:	4.0 mm	2.3 mm
Maximum Stroke:	5.0 mm	8.0 mm

Contacting of FAKRA Connectors

Series FAKRA

Connection Dimensions

Signal Conductor Plug

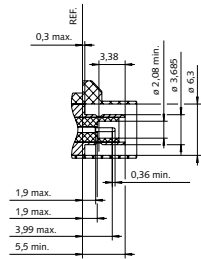

Signal Conductor Jack

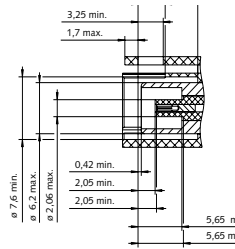

Examples:

FAKRA Signal Conductor Plug



FAKRA Signal Conductor Jack



Contacting of GT13 Connectors

Series GT13

Connection Dimensions

Signal Conductor Plug

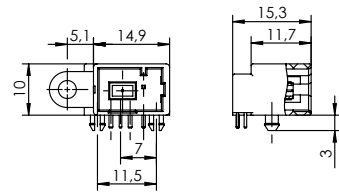

Example:

GT13 Signal Conductor Plug



Contacting of GT16 Connectors

Series GT16

Connection Dimensions

Signal Conductor Plug

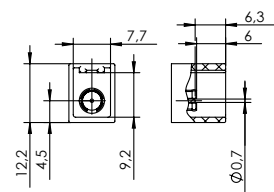

Signal Conductor Jack

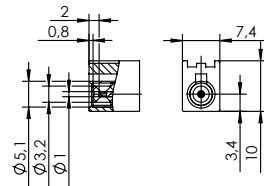

Example:

GT16 Signal Conductor Plug



GT16 Signal Conductor Jack



All specifications are subject to change without prior notification

Contents

FAKRA

Signal Conductor Plug

2 GHz 111
HFS-810, HFS-810 M
HFS-410, HFS-410 M

4 GHz 112
HFS-840, HFS-840 M
HFS-440, HFS-440 M

Signal Conductor Jack

2 GHz 113
HFS-810, HFS-810 M
HFS-410, HFS-410 M

4 GHz 114
HFS-840, HFS-840 M
HFS-440, HFS-440 M

GT13

Signal Conductor Plug

2 GHz 115
HFS-810, HFS-810 4M
HFS-410, HFS-410 4M

4 GHz 116
HFS-840, HFS-840 4M
HFS-440, HFS-440 4M

GT16

Signal Conductor Plug

2 GHz 117
HFS-810, HFS-810 M
HFS-410, HFS-410 M

4 GHz 118
HFS-840, HFS-840 M
HFS-440, HFS-440 M

Signal Conductor Jack

2 GHz 119
HFS-810, HFS-810 M
HFS-410, HFS-410 M

4 GHz 120
HFS-840, HFS-840 M
HFS-440, HFS-440 M

Receptacles (KS) 192 - 194

Spacer of Receptacles (DS) 195

Cable plug assembly (SE) 196 - 199

Tools 200 - 201

Inner Conductor/Signal Conductor 202 - 204

MMBX / MMCPX / MMCK / MMMPX / MBX / MCKX / SMC / SMB / SMC / SMP (X/MAX) / SMP-L / SMP / P-SMP / SMA / PC3.5 / QMA / BMA / BNC / 1.0/2.3 / N / FME / 7/16 / U.FL / W.FL / W.FL2 / X.FL / MM5829 / Reverse SMA / TNC / IEC / F (75 Ω) / FAKRA / GT13 / GT16 / Digital / Switch connector contacting / PCB test point / PCB test point side / Coaxial dipole probe / Accessories

FAKRA, GT13, GT16 Connectors

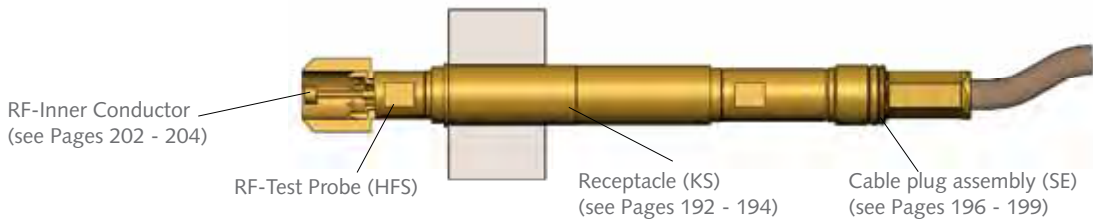

Contacting Example FAKRA:

Contacting of FAKRA Signal Conductor Plug

HFS-810 303 150 A 5342 F

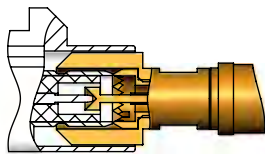

Customizing Example:

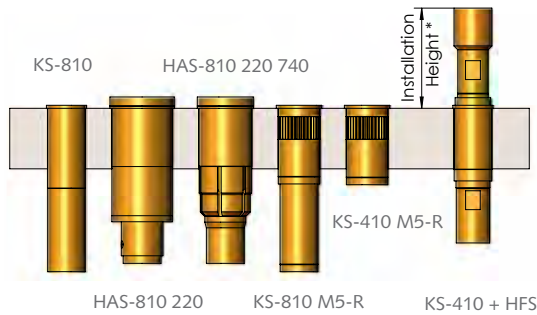

Electrical Data

HFS-810/810 M/810 4M HFS-840/840 M/840 4M

HFS-410/410 M/410 4M HFS-440/440 M/440 4M

Frequency Range with HFS-810/410: up to 2 GHz

Frequency Range with HFS-840/440: up to 4 GHz

Current Rating Outer Conductor: 8–10 A

Current Rating Inner Conductor: 2–3 A

R_i typical Inner Conductor: ≤ 10 mΩ

Impedance Test Probe: 50 Ω

Impedance Cable: 50 Ω

Operating Temperature Range

–40 up to +80° C

Installation Height in Receptacle		KS-810 (F) KS-410 (F) KS-810 M5-(R/F) KS-410 M5-(R/F)	HAS-810 220 (F) HAS-810 220 740 (F)
Variant		*Installation Height HFS in KS	
FAKRA Signal Conductor Plug	...F / ... F M	12.1 mm	13.2 mm
	... FS1 / ... FS1 M		
	... RF3 / ... RF3 M		
FAKRA Signal Conductor Jack	... ZE3 / ... ZE3 M	12.3 mm	13.4 mm
GT13 Signal Conductor Plug	... GT13 / ... GT13 4M	13.9 mm	15.0 mm
GT16 Signal Conductor Plug	... GT16 / ... GT16 M	12.4 mm	13.5 mm
GT16 Signal Conductor Jack	... GT16 F / ... GT16 F M	11.9 mm	13.0 mm

Note:

Further details of receptacles with and without flange connection (F) see pages 192 - 194.

Series:

Available Tip Styles:

Ordering Description:

HFS-810 ...

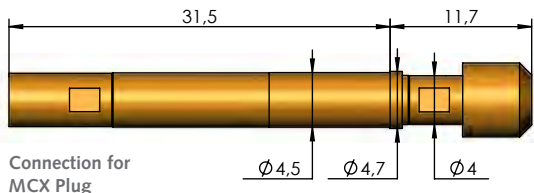

HFS-810 ... M (*)

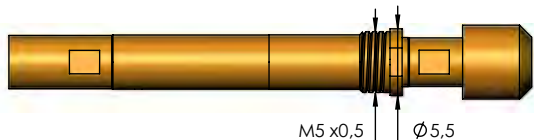

HFS-410 ...

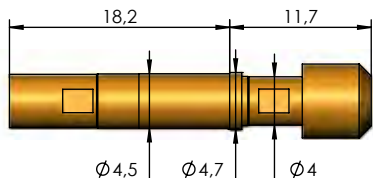

HFS-410 ... M (*)

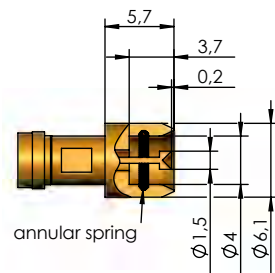
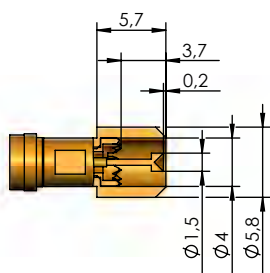
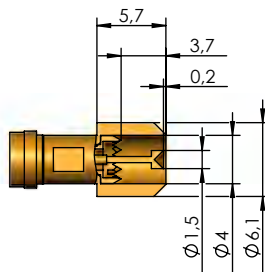
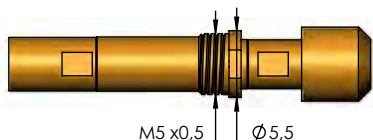

- HFS-810 303 150 A **xx** 42 F
- HFS-810 303 150 A **xx** 42 F M
- HFS-410 303 150 A **xx** 42 F
- HFS-410 303 150 A **xx** 42 F M

Note:
Centering range: ± 0.8 mm

- HFS-810 303 150 A **xx** 42 FS1
- HFS-810 303 150 A **xx** 42 FS1 M
- HFS-410 303 150 A **xx** 42 FS1
- HFS-410 303 150 A **xx** 42 FS1 M

Note: For Connector casing with smaller inside diameter the outer diameter of the Plunger was reduced from Ø 6.1 mm to Ø 5.8 mm. Centering range: ± 0.8 mm

- HFS-810 303 150 A **xx** 42 RF3
- HFS-810 303 150 A **xx** 42 RF3 M
- HFS-410 303 150 A **xx** 42 RF3
- HFS-410 303 150 A **xx** 42 RF3 M

Note: Version with Circular Spring inside the Outer Plunger. For FAKRA Connectors with tight manufacturing tolerances or protruding dielectric. Due to the insertion force of the circular spring recommended for spring forces of the Outer Conductor at working stroke ≥ 6,0 N. Centering range: ± 0.5 mm

Spring force rating

The spring-loaded Inner and Outer Conductor are available with different spring forces. The ordering description is derived by adding up the individual values.

	HFS-810 HFS-810 M				HFS-410 HFS-410 M
Spring Force of Inner Conductor (N)	1.3	2.0	1.3	2.0	1.0
Spring Force of Outer Conductor (N)	4.0	6.0	8.0	8.0	4.0
Character for ordering	53	80	93	99	50

Note: (*)

For usage in the case of vibration, shaking, snapping or assembly upside down.

Mechanical Data

HFS-810 and HFS-810 M

	Outer Cond.	Inner Cond.
Working Stroke:	4.0 mm	2.0 mm
Maximum Stroke:	5.0 mm	3.7 mm

Mechanical Data

HFS-410 and HFS-410 M

	Outer Cond.	Inner Cond.
Working Stroke:	2.0 mm	2.0 mm
Maximum Stroke:	3.0 mm	3.0 mm

FAKRA Signal Conductor Plug

up to 4 GHz
(50 Ω)

HFS-840 / HFS-840 M
HFS-440 / HFS-440 M

Series:

Available Tip Styles:

Ordering Description:

HFS-840 ...

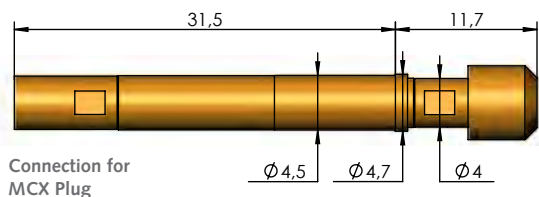

HFS-840 ... M (*)

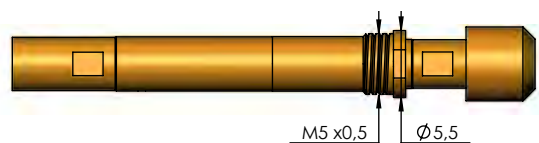

HFS-440 ...

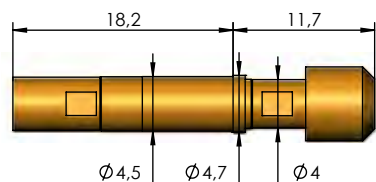

HFS-440 ... M (*)

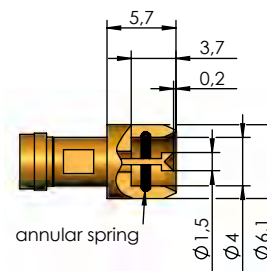
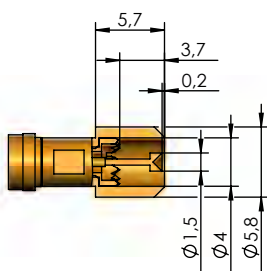
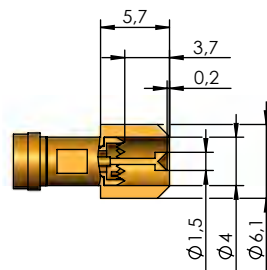
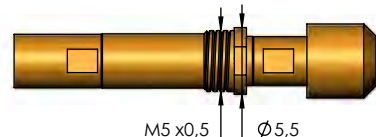

- HFS-840 303 150 A **xx** 42 F
- HFS-840 303 150 A **xx** 42 F M
- HFS-440 303 150 A **xx** 42 F
- HFS-440 303 150 A **xx** 42 F M

Note:
Centering range: ± 0.8 mm

- HFS-840 303 150 A **xx** 42 FS1
- HFS-840 303 150 A **xx** 42 FS1 M
- HFS-440 303 150 A **xx** 42 FS1
- HFS-440 303 150 A **xx** 42 FS1 M

Note: For Connector casing with smaller inside diameter the outer diameter of the Plunger was reduced from Ø 6.1 mm to Ø 5.8 mm. Centering range: ± 0.8 mm

- HFS-840 303 150 A **xx** 42 RF3
- HFS-840 303 150 A **xx** 42 RF3 M
- HFS-440 303 150 A **xx** 42 RF3
- HFS-440 303 150 A **xx** 42 RF3 M

Note: Version with Circular Spring inside the Outer Plunger. For FAKRA Connectors with tight manufacturing tolerances or protruding dielectric. Due to the insertion force of the circular spring recommended for spring forces of the Outer Conductor at working stroke ≥ 6,0 N. Centering range: ± 0.5 mm

Spring force rating

The spring-loaded Inner and Outer Conductor are available with different spring forces. The ordering description is derived by adding up the individual values.

	HFS-840 HFS-840 M				HFS-440 HFS-440 M
Spring Force of Inner Conductor (N)	1.3	2.0	1.3	2.0	1.0
Spring Force of Outer Conductor (N)	4.0	6.0	8.0	8.0	4.0
Character for ordering	53	80	93	99	50

Note: (*)
For usage in the case of vibration, shaking, snapping or assembly upside down.

Mechanical Data HFS-840 and HFS-840 M		
	Outer Cond.	Inner Cond.
Working Stroke:	4.0 mm	2.0 mm
Maximum Stroke:	5.0 mm	3.7 mm

Mechanical Data HFS-440 and HFS-440 M		
	Outer Cond.	Inner Cond.
Working Stroke:	2.0 mm	2.0 mm
Maximum Stroke:	3.0 mm	3.0 mm

Series:

Available Tip Styles:

Ordering Description:

HFS-810 ...

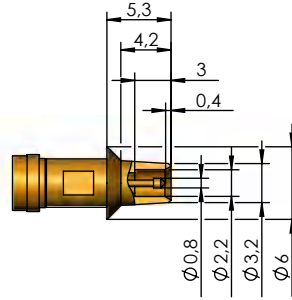
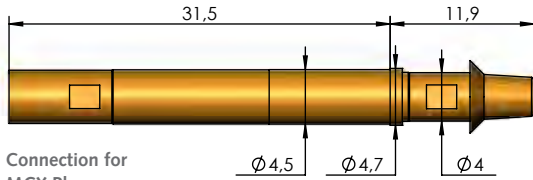

- HFS-810 308 080 A **xx** 42 ZE3
- HFS-810 308 080 A **xx** 42 ZE3 M
- HFS-410 308 080 A **xx** 42 ZE3
- HFS-410 308 080 A **xx** 42 ZE3 M

Note: Version with pre-centering on the inner side of the Connector Outer Contact.
Centering range: ± 0.2 mm

HFS-810 ... M (*)

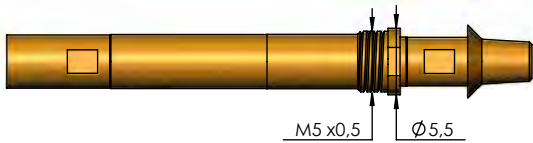

HFS-410 ...

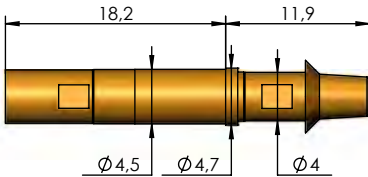

HFS-410 ... M (*)

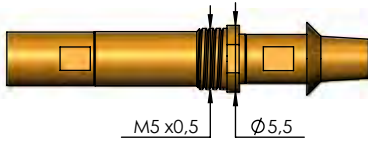

Spring force rating

The spring-loaded Inner and Outer Conductor are available with different spring forces. The ordering description is derived by adding up the individual values.

	HFS-810 HFS-810 M				HFS-410 HFS-410 M
Spring Force of Inner Conductor (N)	1.3	2.0	1.3	2.0	1.0
Spring Force of Outer Conductor (N)	4.0	6.0	8.0	8.0	4.0
Character for ordering	53	80	93	99	50

Note: (*)
For usage in the case of vibration, shaking, snapping or assembly upside down.

Mechanical Data
HFS-810 and HFS-810 M

	Outer Cond.	Inner Cond.
Working Stroke:	4.0 mm	2.0 mm
Maximum Stroke:	5.0 mm	3.7 mm

Mechanical Data
HFS-410 and HFS-410 M

	Outer Cond.	Inner Cond.
Working Stroke:	2.0 mm	2.0 mm
Maximum Stroke:	3.0 mm	3.0 mm

FAKRA Signal Conductor Jack

up to 4 GHz
(50 Ω)

HFS-840 / HFS-840 M
HFS-440 / HFS-440 M

Series:

Available Tip Styles:

Ordering Description:

HFS-840 ...

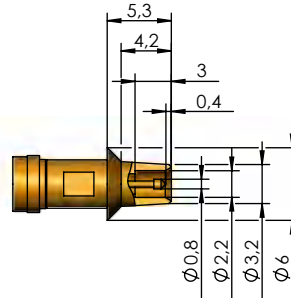
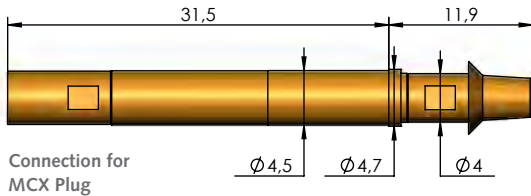

HFS-840 308 080 A **xx** 42 ZE3
HFS-840 308 080 A **xx** 42 ZE3 M
HFS-440 308 080 A **xx** 42 ZE3
HFS-440 308 080 A **xx** 42 ZE3 M

Note: Version with pre-centering on the inner side of the Connector Outer Contact.
Centering range: ± 0.2 mm

HFS-840 ... M (*)

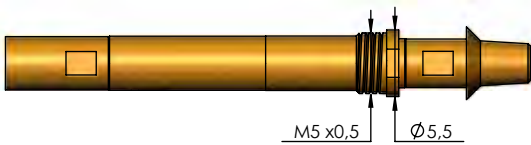

HFS-440 ...

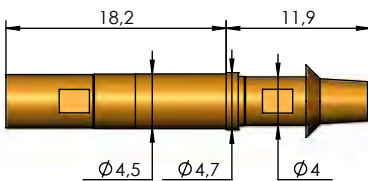

HFS-440 ... M (*)

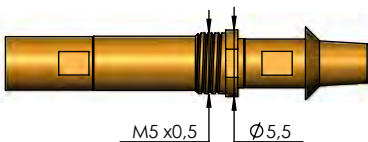

Spring force rating

The spring-loaded Inner and Outer Conductor are available with different spring forces. The ordering description is derived by adding up the individual values.

	HFS-840 HFS-840 M				HFS-440 HFS-440 M
Spring Force of Inner Conductor (N)	1.3	2.0	1.3	2.0	1.0
Spring Force of Outer Conductor (N)	4.0	6.0	8.0	8.0	4.0
Character for ordering	53	80	93	99	50

Note: (*)

For usage in the case of vibration, shaking, snapping or assembly upside down.

Mechanical Data

HFS-840 and HFS-840 M

	Outer Cond.	Inner Cond.
Working Stroke:	4.0 mm	2.0 mm
Maximum Stroke:	5.0 mm	3.7 mm

Mechanical Data

HFS-440 and HFS-440 M

	Outer Cond.	Inner Cond.
Working Stroke:	2.0 mm	2.0 mm
Maximum Stroke:	3.0 mm	3.0 mm

MMBX / MMCP / MMMPX
MMBX / MCBX
SMB / SMC
SMP (X/MAX) / SMP-L / SSMP / P-5SMP
SMA / PC3.5 / QMA
BMA / BNC 1.0/2.3
N / FME / 7/16
U.FL / W.FL / W.FL2 / X.FL / MM5829
Reverse SMA / TNC
IEC / F (75 Ω)
FAKRA / GT13 / GT16
Digital
Switch connector contacting
PCB test point
PCB test point side
Coaxial dipole probe
Accessories

Series:



Available Tip Styles:

Ordering Description:

HFS-810 ...

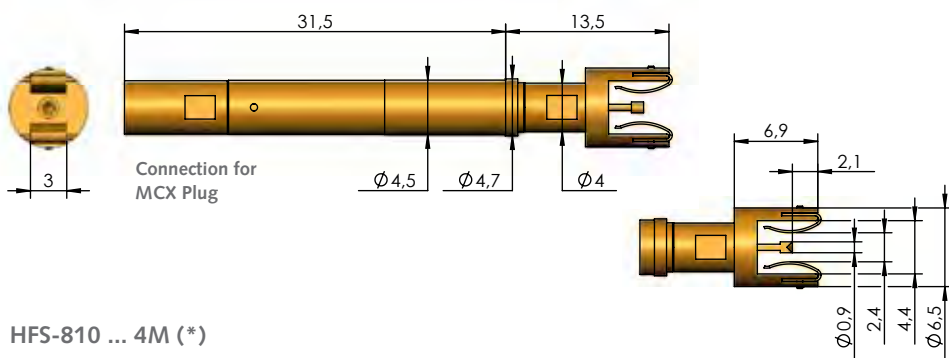

HFS-810 303 090 A **xx** 40 GT13
HFS-810 303 090 A **xx** 40 GT13 4M
HFS-410 303 090 A **xx** 40 GT13
HFS-410 303 090 A **xx** 40 GT13 4M

HFS-810 ... 4M (*)

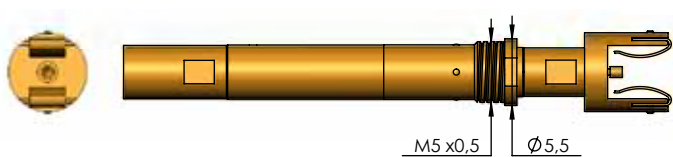

HFS-410 ...

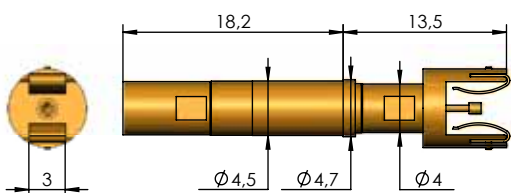

HFS-410 ... 4M (*)

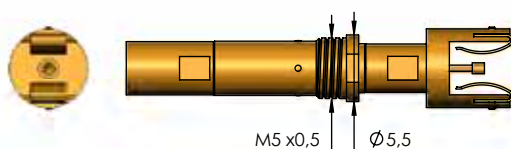

Spring force rating

The spring-loaded Inner and Outer Conductor are available with different spring forces. The ordering description is derived by adding up the individual values.

Note: (*)

For usage in the case of vibration, shaking, snapping or assembly upside down.

The "4M" variant has additional securing crimps that prevent rotation of the pre-determined position of the Test Probe. For applications with Asymmetric Plungers respectively Outer Plungers, that must be assembled in a pre-determined position.

	HFS-810 HFS-810 4M				HFS-410 HFS-410 4M
Spring Force of Inner Conductor (N)	1.3	2.0	1.3	2.0	1.0
Spring Force of Outer Conductor (N)	4.0	6.0	8.0	8.0	4.0
Character for ordering	53	80	93	99	50

Mechanical Data

HFS-810 and HFS-810 4M

	Outer Cond.	Inner Cond.
Working Stroke:	4.0 mm	2.0 mm
Maximum Stroke:	5.0 mm	3.7 mm

Mechanical Data

HFS-410 and HFS-410 4M

	Outer Cond.	Inner Cond.
Working Stroke:	2.0 mm	2.0 mm
Maximum Stroke:	3.0 mm	3.0 mm

GT13 Signal Conductor Plug

up to 4 GHz
(50 Ω)

HFS-840 / HFS-840 4M
HFS-440 / HFS-440 4M

Series:



Available Tip Styles:

Ordering Description:

HFS-840 ...

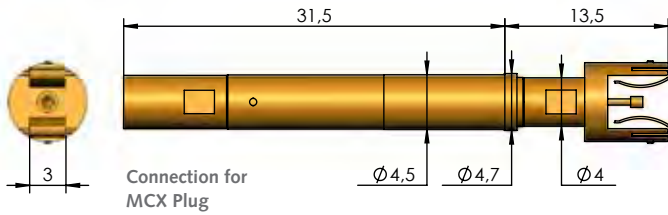

HFS-840 303 090 A **xx** 40 GT13
HFS-840 303 090 A **xx** 40 GT13 4M
HFS-440 303 090 A **xx** 40 GT13
HFS-440 303 090 A **xx** 40 GT13 4M

HFS-840 ... 4M (*)

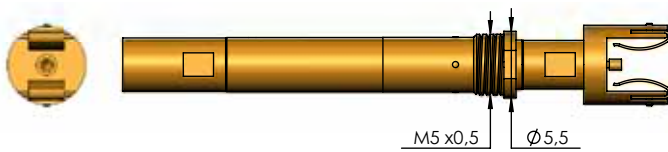

Note: The rectangular Ground Contact of the Connector is contacted by means of the encompassing contact lamellas. The Probes should be aligned accordingly. Centering range: ± 0.3 mm

HFS-440 ...

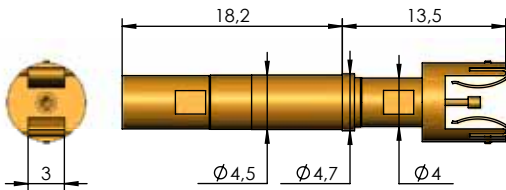

HFS-440 ... 4M (*)

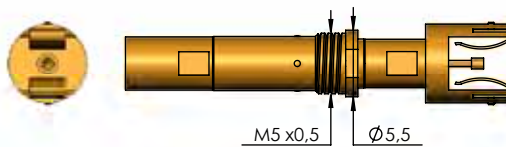

Spring force rating

The spring-loaded Inner and Outer Conductor are available with different spring forces. The ordering description is derived by adding up the individual values.

Note: (*)

For usage in the case of vibration, shaking, snapping or assembly upside down.

The "4M" variant has additional securing crimps that prevent rotation of the pre-determined position of the Test Probe. For applications with Asymmetric Plungers respectively Outer Plungers, that must be assembled in a pre-determined position.

	HFS-840 HFS-840 4M				HFS-440 HFS-440 4M
Spring Force of Inner Conductor (N)	1.3	2.0	1.3	2.0	1.0
Spring Force of Outer Conductor (N)	4.0	6.0	8.0	8.0	4.0
Character for ordering	53	80	93	99	50

Mechanical Data

HFS-840 and HFS-840 4M

	Outer Cond.	Inner Cond.
Working Stroke:	4.0 mm	2.0 mm
Maximum Stroke:	5.0 mm	3.7 mm

Mechanical Data

HFS-440 and HFS-440 4M

	Outer Cond.	Inner Cond.
Working Stroke:	2.0 mm	2.0 mm
Maximum Stroke:	3.0 mm	3.0 mm

MMBX / MMBX / MMMPX / MMCK / MMMPX / MBX / MCX
 SMB / SMC
 SMP (X/ MAX) / SMP-L / SSMP / P-SMP
 SMA / PC3.5 / QMA
 BMA / BNC / 1.0/2.3
 N / FME / 7/16
 U.FL / W.FL / W.FL2 / X.FL / MM5829
 Reverse SMA / TNC
 IEC / F (75 Ω)
 FAKRA / GT13 / GT16
 Digital
 Switch connector contacting
 PCB test point
 PCB test point side
 Coaxial dipole probe
 Accessories

Series:

HFS-810 ...

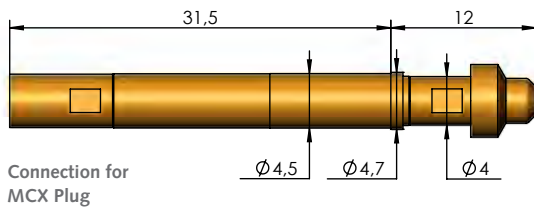

Available Tip Styles:

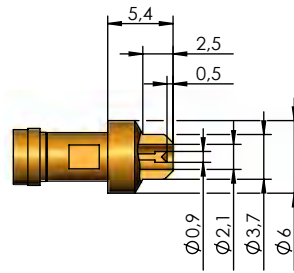

Ordering Description:

- HFS-810 303 090 A **xx** 42 GT16
- HFS-810 303 090 A **xx** 42 GT16 M
- HFS-410 303 090 A **xx** 42 GT16
- HFS-410 303 090 A **xx** 42 GT16 M

Note: Version with pre-centering on the inner side of the Connector Outer Contact. Centering range: ± 0.5 mm

HFS-810 ... M (*)

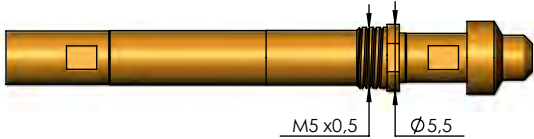

HFS-410 ...

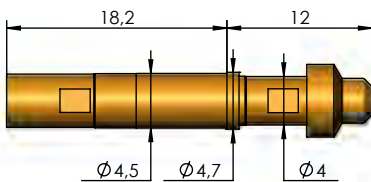

HFS-410 ... M (*)

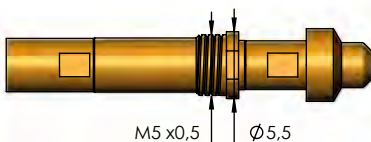

Spring force rating

The spring-loaded Inner and Outer Conductor are available with different spring forces. The ordering description is derived by adding up the individual values.

	HFS-810 HFS-810 M				HFS-410 HFS-410 M
Spring Force of Inner Conductor (N)	1.3	2.0	1.3	2.0	1.0
Spring Force of Outer Conductor (N)	4.0	6.0	8.0	8.0	4.0
Character for ordering	53	80	93	99	50

Note: (*)

For usage in the case of vibration, shaking, snapping or assembly upside down.

Mechanical Data

HFS-810 and HFS-810 M

	Outer Cond.	Inner Cond.
Working Stroke:	4.0 mm	2.0 mm
Maximum Stroke:	5.0 mm	3.7 mm

Mechanical Data

HFS-410 and HFS-410 M

	Outer Cond.	Inner Cond.
Working Stroke:	2.0 mm	2.0 mm
Maximum Stroke:	3.0 mm	3.0 mm

GT16 Signal Conductor Plug

up to 4 GHz
(50 Ω)

HFS-840 / HFS-840 M
HFS-440 / HFS-440 M

Series:

Available Tip Styles:

Ordering Description:

HFS-840 ...

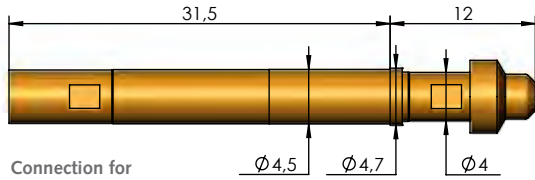

Connection for MCX Plug

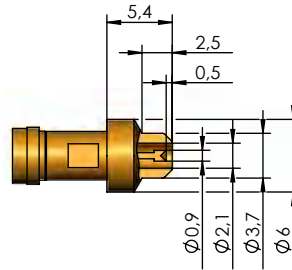

HFS-840 303 090 A **xx** 42 GT16
HFS-840 303 090 A **xx** 42 GT16 M
HFS-440 303 090 A **xx** 42 GT16
HFS-440 303 090 A **xx** 42 GT16 M

Note: Version with pre-centering on the inner side of the Connector Outer Contact.
Centering range: ± 0.5 mm

HFS-840 ... M (*)

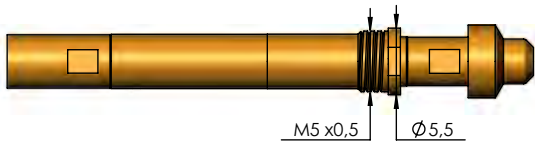

HFS-440 ...

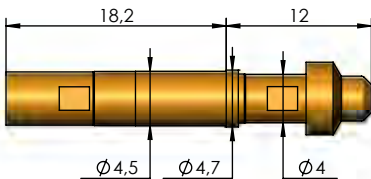

HFS-440 ... M (*)

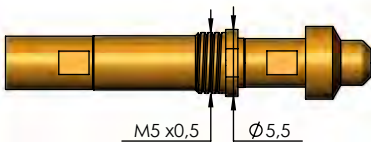

Spring force rating

The spring-loaded Inner and Outer Conductor are available with different spring forces. The ordering description is derived by adding up the individual values.

	HFS-840 HFS-840 M				HFS-440 HFS-440 M
Spring Force of Inner Conductor (N)	1.3	2.0	1.3	2.0	1.0
Spring Force of Outer Conductor (N)	4.0	6.0	8.0	8.0	4.0
Character for ordering	53	80	93	99	50

Note: (*)

For usage in the case of vibration, shaking, snapping or assembly upside down.

Mechanical Data

HFS-840 and HFS-840 M

	Outer Cond.	Inner Cond.
Working Stroke:	4.0 mm	2.0 mm
Maximum Stroke:	5.0 mm	3.7 mm

Mechanical Data

HFS-440 and HFS-440 M

	Outer Cond.	Inner Cond.
Working Stroke:	2.0 mm	2.0 mm
Maximum Stroke:	3.0 mm	3.0 mm

Series:

Available
Tip Styles:

Ordering Description:

HFS-810 ...

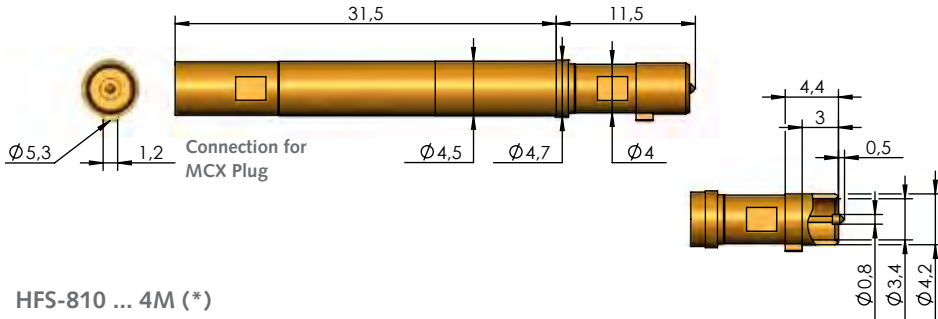

HFS-810 308 080 A **xx** 42 GT16-F
HFS-810 308 080 A **xx** 42 GT16-F 4M
HFS-410 308 080 A **xx** 42 GT16-F
HFS-410 308 080 A **xx** 42 GT16-F 4M

Note: Version with pre-centering on the inner side of the Connector Outer Contact. Ground contact is achieved via the contact lug on the outer diameter of the Outer Plunger.
Centering range: ± 0.5 mm

HFS-810 ... 4M (*)



HFS-410 ...

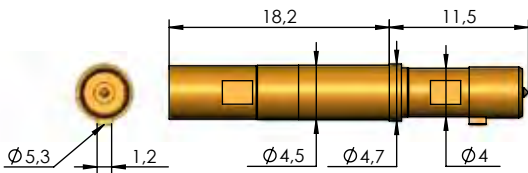

HFS-410 ... 4M (*)

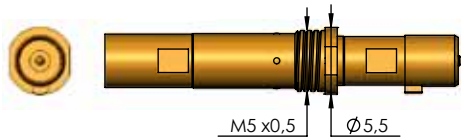

Spring force rating

The spring-loaded Inner and Outer Conductor are available with different spring forces. The ordering description is derived by adding up the individual values.

Note: (*)

For usage in the case of vibration, shaking, snapping or assembly upside down.

The "4M" variant has additional securing crimps that prevent rotation of the pre-determined position of the Test Probe. For applications with Asymmetric Plungers respectively Outer Plungers, that must be assembled in a pre-determined position.

	HFS-810 HFS-810 4M				HFS-410 HFS-410 4M
Spring Force of Inner Conductor (N)	1.3	2.0	1.3	2.0	1.0
Spring Force of Outer Conductor (N)	4.0	6.0	8.0	8.0	4.0
Character for ordering	53	80	93	99	50

Mechanical Data HFS-810 and HFS-810 M

	Outer Cond.	Inner Cond.
Working Stroke:	4.0 mm	2.0 mm
Maximum Stroke:	5.0 mm	3.7 mm

Mechanical Data HFS-410 and HFS-410 M

	Outer Cond.	Inner Cond.
Working Stroke:	2.0 mm	2.0 mm
Maximum Stroke:	3.0 mm	3.0 mm

GT16 Signal Conductor Jack

up to 4 GHz
(50 Ω)

HFS-840 / HFS-840 M
HFS-440 / HFS-440 M

Series:

Available Tip Styles:

Ordering Description:

HFS-840 ...

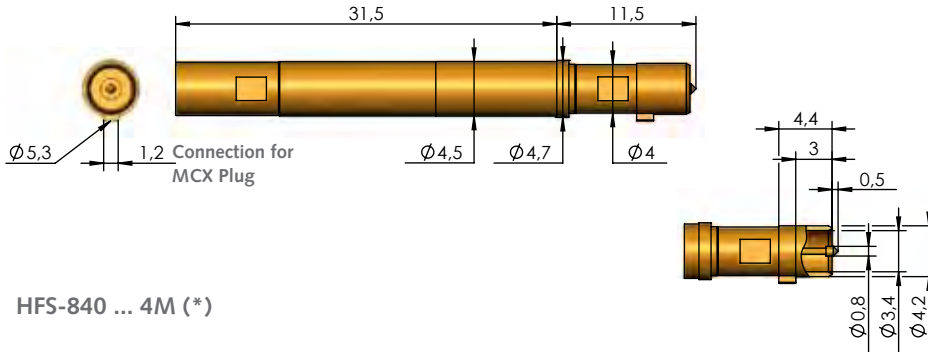

HFS-840 ... 4M (*)



HFS-440 ...

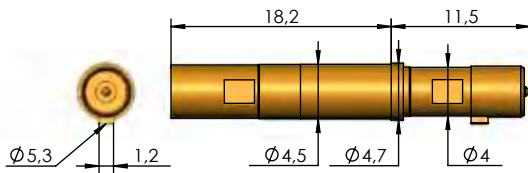

HFS-440 ...4M (*)

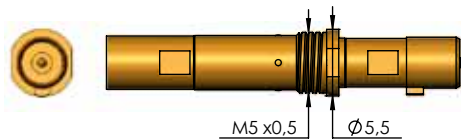

HFS-840 308 080 A **xx** 42 GT16-F
HFS-840 308 080 A **xx** 42 GT16-F 4M
HFS-440 308 080 A **xx** 42 GT16-F
HFS-440 308 080 A **xx** 42 GT16-F 4M

Note: Version with pre-centering on the inner side of the Connector Outer Contact. Ground contact is achieved via the contact lug on the outer diameter of the Outer Plunger. Centering range: ± 0.5 mm

Spring force rating

The spring-loaded Inner and Outer Conductor are available with different spring forces. The ordering description is derived by adding up the individual values.

Note: (*)

For usage in the case of vibration, shaking, snapping or assembly upside down.

The "4M" variant has additional securing crimps that prevent rotation of the pre-determined position of the Test Probe. For applications with Asymmetric Plungers respectively Outer Plungers, that must be assembled in a pre-determined position.

	HFS-840 HFS-840 4M				HFS-440 HFS-440 4M
Spring Force of Inner Conductor (N)	1.3	2.0	1.3	2.0	1.0
Spring Force of Outer Conductor (N)	4.0	6.0	8.0	8.0	4.0
Character for ordering	53	80	93	99	50

Mechanical Data

HFS-840 and HFS-840 M

	Outer Cond.	Inner Cond.
Working Stroke:	4.0 mm	2.0 mm
Maximum Stroke:	5.0 mm	3.7 mm

Mechanical Data

HFS-440 and HFS-440 M

	Outer Cond.	Inner Cond.
Working Stroke:	2.0 mm	2.0 mm
Maximum Stroke:	3.0 mm	3.0 mm

Contacting of HSD Connectors for differential signal transmission

Series HSD

Connection Dimensions

Signal Conductor Plug

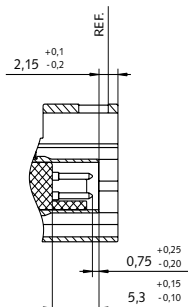

Signal conductor Jack

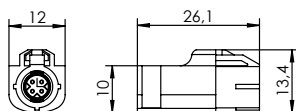

Example:

HSD Signal Conductor Plug



HSD Signal Conductor Jack



Contacting of USB Mini Connectors for differential signal transmission

Series USB Mini

Connection Dimensions

Signal Conductor Plug

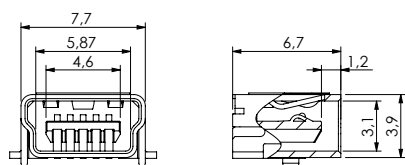

Example:

USB Mini Signal Conductor Plug

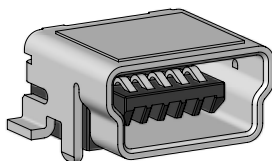

Contacting of MX38 Connectors for differential signal transmission

Series MX38

Connection Dimensions

Signal Conductor Jack

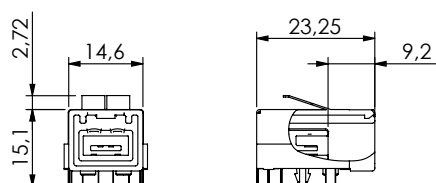

Example:

MX38 Signal Conductor Jack



All specifications are subject to change without prior notification

Contents

HSD

Signal Conductor Plug

HFS-819 124 - 127

Signal Conductor Jack

HFS-819 128

USB Mini

Signal Conductor Plug

HFS-821 129

MX38

Signal Conductor Jack

HFS-821 130

MX48 s. page 131

MX49 s. page 132

MX62 s. page 133

MX68 s. page 134

USB, RJ, HDMI s. page 136 - 137

Receptacles (KS) 192 - 194

Spacer of Receptacles (DS) 195

Cable plug assembly (SE) 196 - 199

Tools 200 - 201

Inner Conductor/ Signal Conductor 201 - 204

MMBX / MMCK / MMMPX / MBX / MCK
SMB / SMC
SMP (X/MAX) / SMP-L 5SMP / P-5MP
SMA / PC3.5 QMA
BMA / BNC 1,0/2,3
N / FME / 7/16
U.FL / W.FL / W.FL2 / X.FL / MM5829
Reverse SMA / TNC
IEC / F (75 Ω)
FAKRA / GT13 / GT16
Digital
Switch connector contacting
PCB test point
PCB test point side
Coaxial dipole probe
Accessories

MX48

Signal Conductor Jack

HFS-821 131

MX49

Signal Conductor Jack

HFS-821 132

MX62

Signal Conductor Jack

HFS-821 133

MX68

Signal Conductor Jack

HFS-821 134

Receptacles (KS) 192 - 194

Spacer of Receptacles (DS) 195

Cable plug assembly (SE) 196 - 199

Tools 200 - 201

Inner Conductor/Signal Conductor 202 - 204

Contacting of MX48 Connectors for differential signal transmission

Series MX48

Connection Dimensions
Signal Conductor Jack

Example:
MX48 Signal Conductor Jack

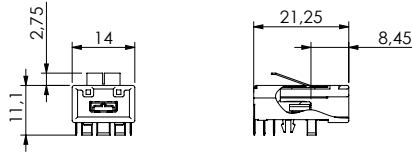

Contacting of MX49 Connectors for differential signal transmission

Series MX49

Connection Dimensions
Signal Conductor Jack

Example:
MX49 Signal Conductor Jack

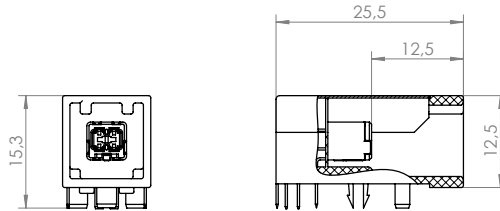

Contacting of MX62 Connectors for differential signal transmission

Series MX62

Connection Dimensions
Signal Conductor Jack

Example:
MX62 Signal Conductor Jack

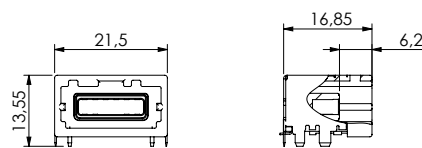

Contacting of MX68 Connectors for differential signal transmission

Series MX68

Connection Dimensions
Signal Conductor Jack

Example:
MX68 Signal Conductor Jack

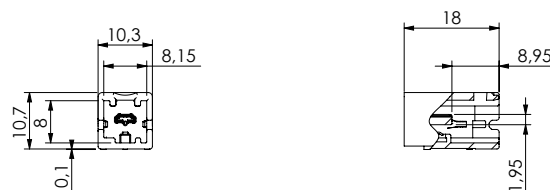

HSD / USB-Mini / MX-Connectors for differential signal transmission

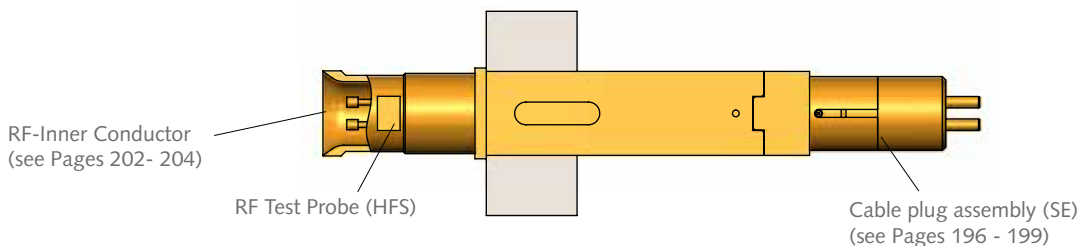

Contacting Example HSD:

Contacting of HSD Signal Conductor Plug

HFS-819 303 090 A 12743-V2

Contacting of HSD Signal Conductor Jack

HFS-819 355 051 A 12742-V4

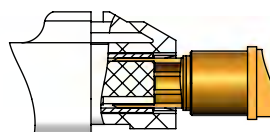
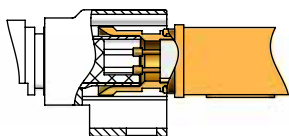

Customizing Example:

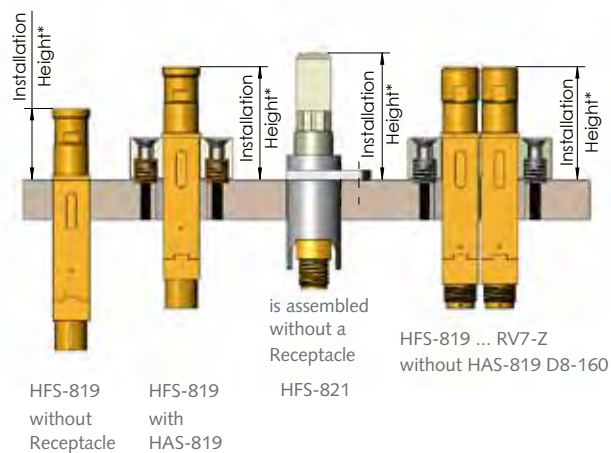

Installation Height in Receptacle	HAS-819	HAS-819 D8-160	without KS
Variant	*Installation Height HFS in KS		
HSD-Signal Conductor Plug	... F2-Z	---	22.9 mm
	... V2	---	14.4 mm
	... RV5	---	14.4 mm
	... V2-Z	22.9 mm	---
	... RV5-Z	22.9 mm	---
HSD-Signal Conductor Jack	... RV5-H3	22.9 mm	14.4 mm
	... RV7-Z	22.9 mm	14.4 mm
USB Mini Signal Conductor Jack	... V8	25.8 mm	17.3 mm
	... V8-Z	---	17.3 mm
MX38-Signal Conductor Jack	... MX38	---	27.0 mm
MX48-Signal Conductor Jack	... MX48	---	27.4 mm
MX49-Signal Conductor Jack	... USB-T	---	25.7 mm
MX62-Signal Conductor Jack	...MX62	---	28.7 mm
MX68-Signal Conductor Jack	... MX68	---	27.7 mm

Electrical Data

	HFS-819	HFS-821
Data transmission with HFS-819:	Gbit/s	
Data transmission with HFS-821:	Gbit/s	
Current Rating Outer Conductor:	8–10 A	
Current Rating Inner Conductor:	2–3 A	
R _i typical Inner Conductor:	≤ 10 mΩ	
Impedance Test Probe:	100 Ω	

Operating Temperature Range

–40 up to +80° C

Note:

Further details of receptacles with and without flange connection (F) see pages 192 - 194.

MMBX / MMCP / MMMPX
MMBX / MCB
SMB / SMC
SMP (X/MAX) / SMP-L / SMP / P-SMP
SMA / PC3.5 QMA
BMA / BNC 1.0/2.3
N / FME / 7/16
U.FL / W.FL / W.FL2 / X.FL / MM5829
Reverse SMA / TNC
IEC / F (75 Ω)
FAKRA / GT16
Digital
Switch connector contacting
PCB test point
PCB test point side
Coaxial dipole probe
Accessories

HSD Signal Conductor Plug

Gbit/s
(100 Ω)

HFS-819
with Plug Connection

Series:

Available
Tip Styles:

Ordering Description:

HFS-819 ... with Plug Connection

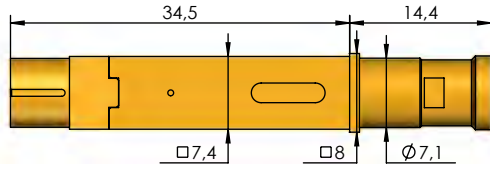

Connection for
Plug SE-819-V2

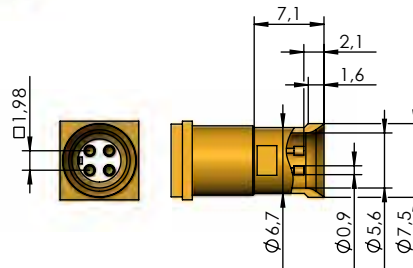

HFS-819 303 090 A **xxx** 43 V2

Note: Version with passive tip-style on Outer Plunger and Inner Conductor with tip-style 03 (inverse cone).
Centering range: ± 0.8 mm

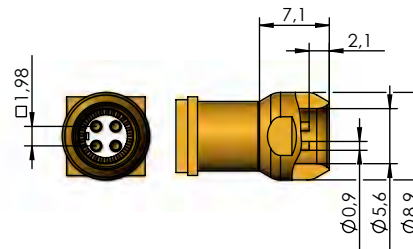

HFS-819 303 090 A **xxx** 43 RV5

Note: Version with enlarged centering range and aggressive serrated tip-style on the Outer Plunger for better contacting reliability on contaminated surfaces. Inner Conductor with tip-style 03 (inverse cone).
Centering range: ± 1.0 mm

Spring force rating

The spring-loaded Inner and Outer Conductor are available with different spring forces. The ordering description is derived by adding up the individual values.

Note:

The series HFS-819 is non-rotatable and has a position detection marking. This design enables contacting of coded 9-pole Connectors. The HFS-819 can be either directly pressed into a mounting plate without usage of a Receptacle or float-assembled by means of the flex-mounting Receptacle HAS-819 (see Receptacles pages 192 - 194).

	HFS-819	
Spring Force of Inner Conductor (N)	4 x 1.3	4 x 1.3
Spring Force of Outer Conductor (N)	7.5	15.5
Character for ordering	127	207

Mechanical Data

HFS-819

	Outer Cond.	Inner Cond.
Working Stroke:	5.0 mm	2.0 mm
Maximum Stroke:	6.0 mm	3.7 mm

Series:



Available
Tip Styles:

Ordering Description:

HFS-819 ... with Flange and flexible bearing

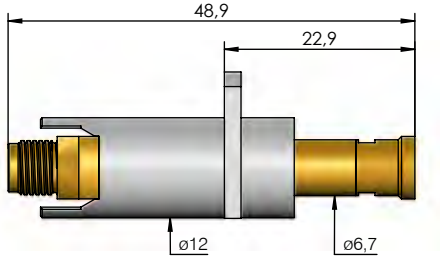

Connection for Screw-in Plug
SE-819-V5-Z

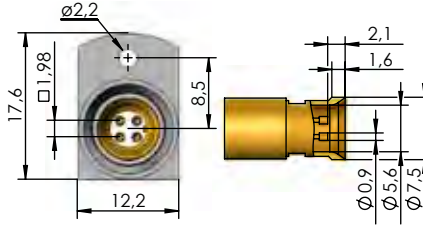

HFS-819 303 090 A **xxx** 43 F2-Z

Note:
Centering range: ± 1,0 mm

Spring force rating

The spring-loaded Inner and Outer Conductor are available with different spring forces. The ordering description is derived by adding up the individual values.

Note:

The series HFS-819 is non-rotatable and has a position detection marking. This design enables contacting of coded 4-pole Connectors. The HFS-819 can be either directly pressed into a mounting plate without usage of a Receptacle or float-assembled by means of the flex-mounting Receptacle HAS-819 (see Receptacles pages 192 - 194).

	HFS-819	
Spring Force of Inner Conductor (N)	4 x 1.3	4 x 1.3
Spring Force of Outer Conductor (N)	7.5	15.5
Character for ordering	127	207

Mechanical Data

HFS-819

	Outer Cond.	Inner Cond.
Working Stroke:	5.0 mm	2.0 mm
Maximum Stroke:	6.0 mm	3.7 mm

HSD Signal Conductor Plug

Gbit/s
(100 Ω)

HFS-819
with Screw-in Connection

Series:

Available
Tip Styles:

Ordering Description:

HFS-819 ... with Screw-in Connection

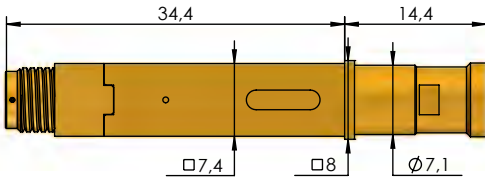

Connection for Screw-in Plug
SE-819-V5-Z

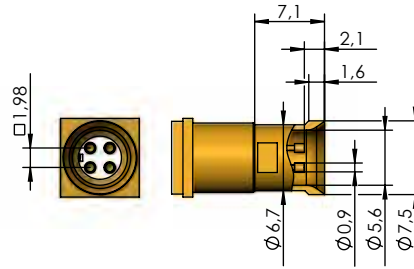

HFS-819 303 090 A **xxx** 43 V2-Z

Note: Version with passive tip-style on Outer Plunger and Inner Conductor with tip-style 03 (inverse cone).
Centering range: ± 0.8 mm

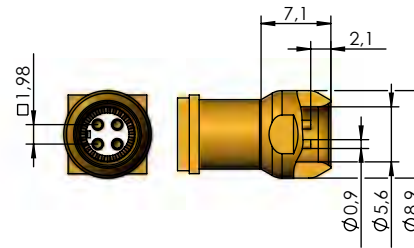

HFS-819 303 090 A **xxx** 43 RV5-Z

Note: Version with enlarged centering range and aggressive serrated tip-style on the Outer Plunger for better contacting reliability on contaminated surfaces. Inner Conductor with tip-style 03 (inverse cone).
Centering range: ± 1.0 mm

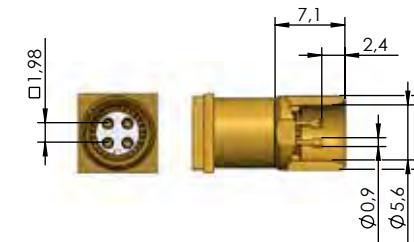

HFS-819 303 090 A **xxx** 43 RV7-Z

Note: Version with reduced tip diameter to contact double HSD connector. Two radio frequency probes (HFS) of this version, without receptacles, are mounted in the HAS-819 D8-160 probe plate (see page 194).
Centering range: ± 0.3 mm

Spring force rating

The spring-loaded Inner and Outer Conductor are available with different spring forces. The ordering description is derived by adding up the individual values.

Note:

The series HFS-819 is non-rotatable and has a position detection marking. This design enables contacting of coded 4-pole Connectors. The HFS-819 can be either directly pressed into a mounting plate without usage of a Receptacle or float-assembled by means of the flex-mounting Receptacle HAS-819. (See Receptacles pages 192 - 194).

	HFS-819	
Spring Force of Inner Conductor (N)	4 x 1.3	4 x 1.3
Spring Force of Outer Conductor (N)	7.5	15.5
Character for ordering	127	207

Mechanical Data

HFS-819

	Outer Cond.	Inner Cond.
Working Stroke:	5.0 mm	2.0 mm
Maximum Stroke:	6.0 mm	3.7 mm

Series:

Available
Tip Styles:

Ordering Description:

HFS-819 ... with Connection for HSD Jack

HFS-819 319 090 A **xxx** 43 RV5-H3

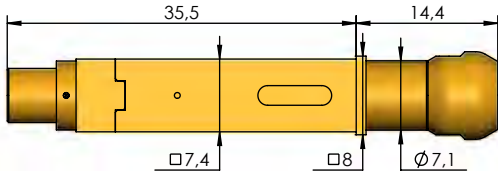

Connection for Screw Plug
SE-819-V2

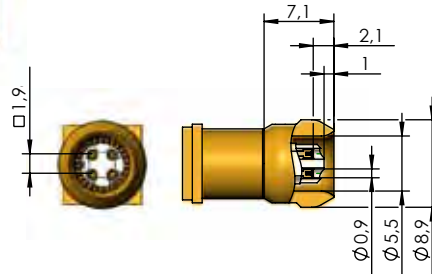

Note:
Centering range: ± 1,0 mm

Spring force rating

The spring-loaded Inner and Outer Conductor are available with different spring forces. The ordering description is derived by adding up the individual values.

Note:

The series HFS-819 is non-rotatable and has a position detection marking. This design enables contacting of coded 4-pole Connectors. The HFS-819 can be either directly pressed into a mounting plate without usage of a Receptacle or float-assembled by means of the flex-mounting Receptacle HAS-819. (See Receptacles pages 192 - 194).

	HFS-819	
Spring Force of Inner Conductor (N)	4 x 1.3	4 x 1.3
Spring Force of Outer Conductor (N)	7.5	15.5
Character for ordering	127	207

Mechanical Data

HFS-819

	Outer Cond.	Inner Cond.
Working Stroke:	5.0 mm	2.0 mm
Maximum Stroke:	6.0 mm	3.7 mm

HSD Signal Conductor Jack

Gbit/s HFS-819 with Plug Connection
(100 Ω) HFS-819 with Screw-in Connection

Series:

Available Tip Styles:

Ordering Description:

HFS-819 ... V8 with Plug Connection

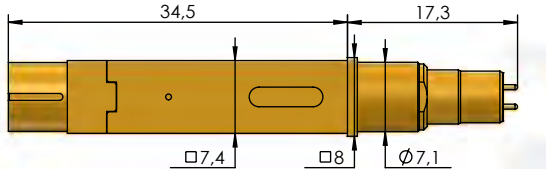

Connection for Plug
SE-819-V2

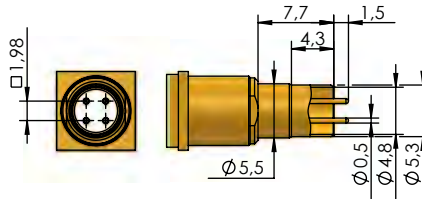

HFS-819 355 051 A **xxx** 42 V8

Note: Version with Plug Connection.
Centering range: ± 0.2 mm

HFS-819 ... V8-Z with Screw-in Connection

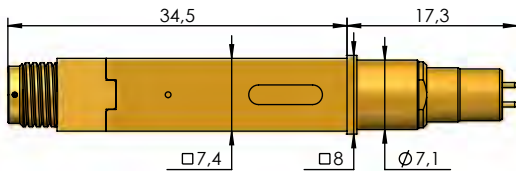

Connection for screw-in Plug
SE-819-V2

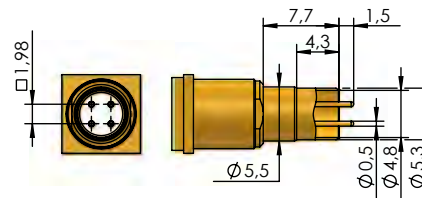

HFS-819 355 051 A **xxx** 42 V8-Z

Note: Version with screw-in Connection.
Centering range: ± 0.2 mm

Note:

The series HFS-819 is non-rotatable and has a position detection marking. This design enables contacting of coded 4-pole Connectors. The HFS-819 can be either directly pressed into a mounting plate without usage of a Receptacle or float-assembled by means of the flex-mounting Receptacle HAS-819 (see Receptacles pages 192 - 194).

	HFS-819	
Spring Force of Inner Conductor (N)	4 x 1.3	4 x 1.3
Spring Force of Outer Conductor (N)	7.5	15.5
Character for ordering	127	207

Mechanical Data

HFS-819

	Outer Cond.	Inner Cond.
Working Stroke:	5.0 mm	2.0 mm
Maximum Stroke:	6.0 mm	3.7 mm

Series:



Available Tip Styles:

Ordering Description:

HFS-821 ...

HFS-821 313 050 A **xx** 05 USB-Mini

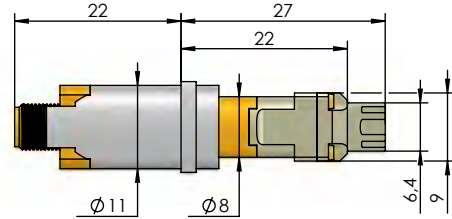
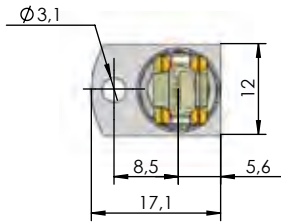

Connection for USB-Mini Plug

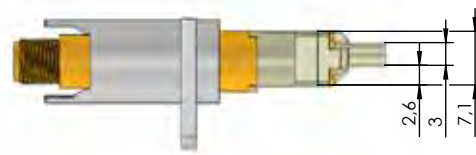

Note: The series HFS-821 is non-rotatable. With this it can be aligned to a USB Mini Connector. Apart from this it is float-mounted and can balance out an axial offset of ± 1.0°. After a minimum contacting stroke of 0.5 mm the Probe can balance out radial positioning inaccuracies of the Connector by up to ± 3.5°. Centering range: ± 0.6 mm

	HFS-821
Spring Force of Inner Conductor (N)	Inner conductor not spring-loaded
Spring Force of Outer Conductor (N)	10.0
Character for ordering	99

Note:
The RF Probes series HFS-821 are mounted by means of a flange connection and a screw.

Mechanical Data	HFS-821	
	Outer Cond.	Inner Cond.
Working Stroke:	3,5 mm	not spring
Maximum Stroke:	5,0 mm	loaded

Mechanical Data	HFS-821	
Axial off-set:	1,0 mm	
Radial positioning:	± 3,5° (after min. 0,5 mm Stroke)	

MMBX / MMCP / MMCPX / MMBX / MMCP
SMB / SMC
SMP (X/MAX) / SMP-L / SSMP / P-SMP
SMA / PC3.5 QMA
BMA / BNC 1.0/2.3
N / FME / 7/16
U.FL / W.FL / W.FL2 / X.FL / MM5829
Reverse SMA / TNC
IEC / F (75 Ω)
FAKRA / GT13 / GT16
Digital
Switch connector contacting
PCB test point
PCB test point side
Coaxial dipole probe
Accessories

MX38 Signal Conductor Jack

Gbit/s
(100 Ω)

HFS-821

Series:



Available
Tip Styles:

Ordering Description:

HFS-821 ...

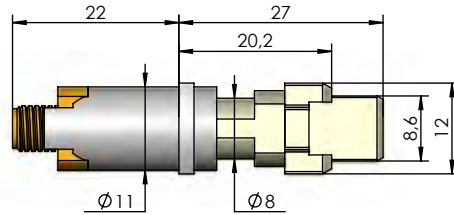
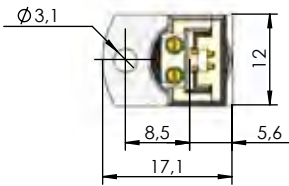

Connection
for MX38 Plug



HFS-821 305 080 A **xx** 05 MX38

Note: The series HFS-821 is non-rotatable. With this it can be aligned to a MX38 Connector. Apart from this it is float-mounted and can balance out an axial off-set of $\pm 1.0^\circ$. After a minimum contacting stroke of 0.5 mm the Probe can balance out radial positioning inaccuracies of the Connector by up to $\pm 3.5^\circ$.
Centering range: ± 0.6 mm

	HFS-821
Spring Force of Inner Conductor (N)	Inner conductor not spring-loaded
Spring Force of Outer Conductor (N)	10.0
Character for ordering	99

Note:

The RF Probes series HFS-821 are mounted by means of a flange connection and a screw.

Mechanical Data

HFS-821

	Outer Cond.	Inner Cond.
Working Stroke:	3.5 mm	not spring loaded
Maximum Stroke:	5.0 mm	loaded

Mechanical Data

HFS-821

Axial off-set:	± 1.0 mm
Radial positioning:	$\pm 3.5^\circ$ (after min. 0.5 mm Stroke)

Series:



Available Tip Styles:

Ordering Description:

HFS-821 ...

HFS-821 302 045 A **xx** 05 MX48

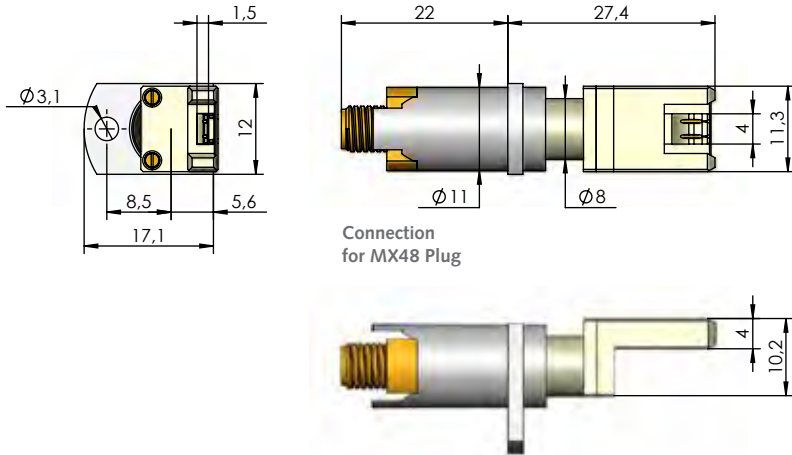

Note: The series HFS-821 is non-rotatable. With this it can be aligned to a MX48 Connector. Apart from this it is float-mounted and can balance out an axial off-set of ± 1.0°. After a minimum contacting stroke of 0.5 mm the Probe can balance out radial positioning inaccuracies of the Connector by up to ± 3.5°. Centering range: ± 0.6 mm

	HFS-821
Spring Force of Inner Conductor (N)	Inner conductor not spring-loaded
Spring Force of Outer Conductor (N)	10.0
Character for ordering	99

Note: The RF Probes series HFS-821 are mounted by means of a flange connection and a screw.

Mechanical Data	Outer Cond.	Inner Cond.
HFS-821		
Working Stroke:	3.5 mm	not spring loaded
Maximum Stroke:	5.0 mm	loaded

Mechanical Data	
HFS-821	
Axial off-set:	± 1.0 mm
Radial positioning:	± 3.5° (after min. 0.5 mm Stroke)

MX49 Signal Conductor Jack

GBit/s
(100 Ω)

HFS-821

Series:



HFS-821 ...

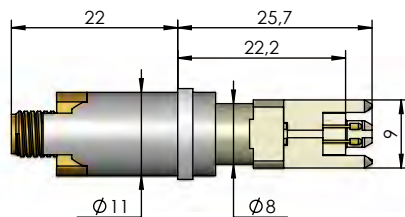
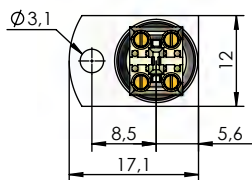

Connection for Screw-in Plug SE-821 MX49



Ordering Description:

HFS-821 302 045 A **xx** 05 MX49

Note: The series HFS-821 is non-rotatable. With this it can be aligned to a MX49 Connector. Apart from this it is float-mounted and can balance out an axial off-set of ± 1.0 mm. After a minimum contacting stroke of 0.5 mm the Probe can balance out radial positioning inaccuracies of the Connector by up to $\pm 3.5^\circ$. Centering range: ± 0.6 mm

	HFS-821
Spring Force of Inner Conductor (N)	Inner conductor not spring-loaded
Spring Force of Outer Conductor (N)	10.0
Character for ordering	99

Note:

The RF Probes series HFS-821 are mounted by means of a flange connection and a screw.

Mechanical Data

HFS-821

	Outer Cond.	Inner Cond.
Working Stroke:	3.5 mm	not spring-loaded
Maximum Stroke:	5.0 mm	loaded

Mechanical Data

HFS-821

Axial off-set:	± 1.0 mm
Radial positioning:	$\pm 3.5^\circ$ (after min. 0.5 mm Stroke)

Series:



HFS-821 ...

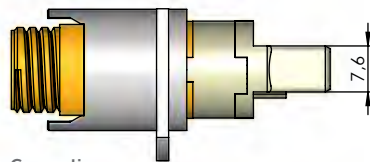
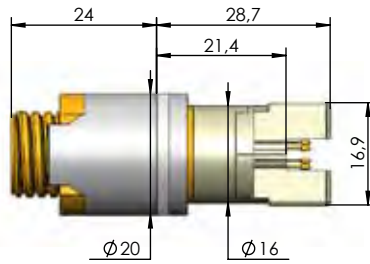
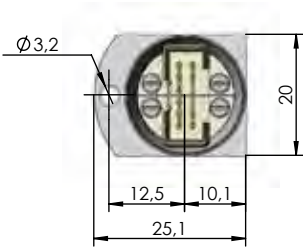

Connection SE-821 MX62

Ordering Description:

HFS-821 302 045 A **xx** 05 MX62

Note: The series HFS-821 is non-rotatable. With this it can be aligned to a MX62 Connector. Apart from this it is float-mounted and can balance out an axial off-set of ± 0.9 mm. After a minimum contacting stroke of 0.5 mm the Probe can balance out radial positioning inaccuracies of the Connector by up to $\pm 3.5^\circ$. Centering range: ± 0.7 mm

	HFS-821
Spring Force of Inner Conductor (N)	Inner conductor not spring-loaded
Spring Force of Outer Conductor (N)	10.0
Character for ordering	99

Note:
The RF Probes series HFS-821 are mounted by means of a flange connection and a screw.

Mechanical Data	
HFS-821	
Working Stroke:	3.5 mm not spring-loaded
Maximum Stroke:	5.0 mm

Mechanical Data	
HFS-821	
Axial off-set:	± 0.9 mm
Radial positioning:	$\pm 3.5^\circ$ (after min. 0.5 mm Stroke)

MX68 Signal Conductor Jack

Gbit/s
(100 Ω)

HFS-821

Series:



HFS-821 ...

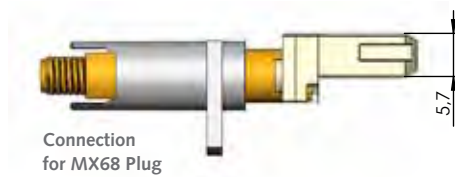
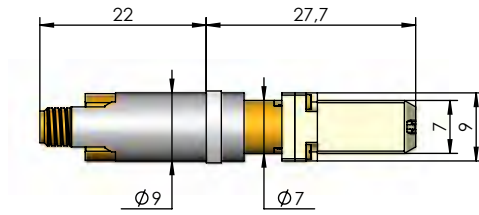
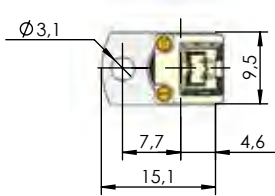

Ordering Description:

HFS-821 302 045 A **xx** 05 MX68

Note: The series HFS-821 is non-rotatable. With this it can be aligned to a MX68 Connector. Apart from this it is float-mounted and can balance out an axial off-set of ± 0.5 mm. After a minimum contacting stroke of 0.5 mm the Probe can balance out radial positioning inaccuracies of the Connector by up to $\pm 2.0^\circ$. Centering range: ± 0.5 mm

	HFS-821
Spring Force of Inner Conductor (N)	Inner conductor not spring-loaded
Spring Force of Outer Conductor (N)	10.0
Character for ordering	99

Note:

The RF Probes series HFS-821 are mounted by means of a flange connection and a screw.

Mechanical Data

HFS-821

	Outer Cond.	Inner Cond.
Working Stroke:	3.5 mm	not spring-loaded
Maximum Stroke:	5.0 mm	loaded

Mechanical Data

HFS-821

Axial off-set:	± 0.5 mm
Radial positioning:	$\pm 2.0^\circ$ (after min. 0.5 mm Stroke)

Contacting of USB Connectors for differential signal transmission

Examples:

4-channel, Type A
Signal Conductor Jack

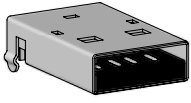

4-channel, Type B
Signal Conductor Jack

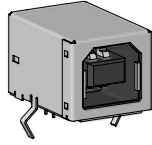

Mini, 4-channel, Type B
Signal Conductor Jack

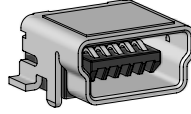

Micro, 4-channel, Type B
Signal Conductor Jack

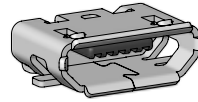

Contacting of RJ Connectors for differential signal transmission

Examples:

RJ-10, 4-channel
Signal Conductor Jack

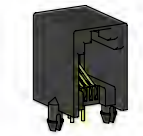

RJ-12, 6-channel
Signal Conductor Jack

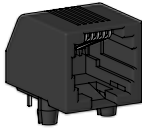

RJ-45, 8-channel
Signal Conductor Jack

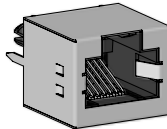

RJ-50, 10-channel
Signal Conductor Jack

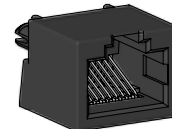

Contacting of HDMI-, TAE- und DC Connectors for differential signal transmission

Examples:

HDMI, 19-channel
Signal Conductor Jack

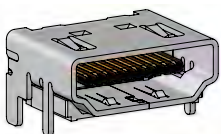

TAE, 6-channel
Signal Conductor Jack



DC-Power, Ø 2,1
Signal Conductor Jack

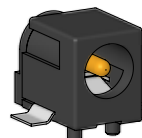

Contents

USB

136

Signal Conductor Jack

4-channel, Type A

4-channel, Type B

Mini, 5-channel, Type B

Micro, 5-channel, Type B

RJ

137

Signal Conductor Jack

RJ-10, 4-channel

RJ-12, 6-channel

RJ-45, 8-channel

RJ-50, 10-channel

HDMI / TAE / DC

136

Signal Conductor Jack

HDMI, 19-channel

TAE, 6-channel

DC-Power

Mounting Sockets

137

for 4-channel plugs

for 6-channel plugs and USB

for 8-channel and 10-channel plugs

USB Signal Conductor Jack

Gbit/s
(100 Ω)

PS-USB

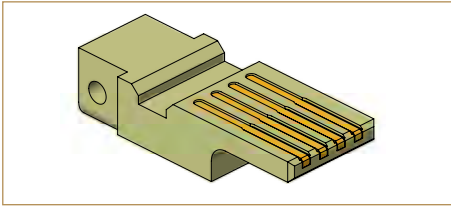

Description	USB connector, type A
Plug	Four-terminal
Casing material	High performance plastic
Electrical design	Max. 40 V / Max. 2,5 A
Article number	21071
Connection cycles	Approx. 100.000

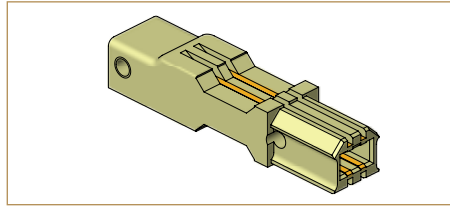

Description	USB connector, type B
Plug	Four-terminal
Casing material	High performance plastic
Electrical design	Max. 40 V
Article number	17829
Connection cycles	Approx. 100.000

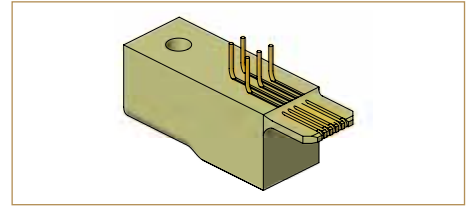

Description	USB connector Mini, type B
Plug	Five-terminal
Casing material	High performance plastic
Electrical design	Max. 40 V
Article number	21072
Connection cycles	Approx. 70.000

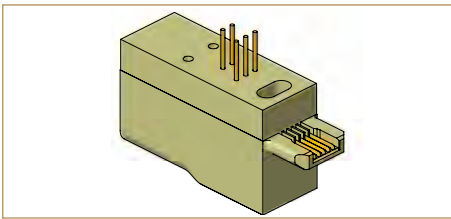

Description	USB connector Micro, type B
Plug	Five-terminal
Casing material	High performance plastic
Electrical design	max. 40 V
Article number	34816
Connection cycles	Approx. 50.000

HDMI-, TAE-, DC-Power-Signal Conductor Jack

Gbit/s
(100 Ω)

PS-HDMI
PS-TAE
PS-Power DC

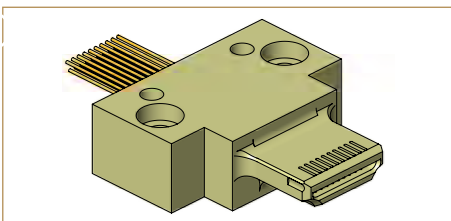

Description	HDMI connector
Plug	Nineteen-terminal
Casing material	High performance plastic
Electrical design	Max. 40 V
Article number	34814
Connection cycles	Approx. 100.000

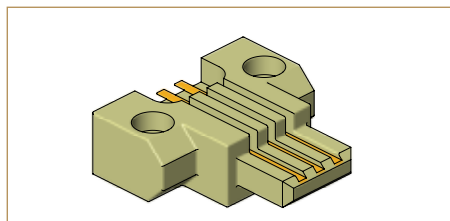

Description	TAE connector
Plug	Six-terminal
Casing material	High performance plastic
Electrical design	Max. 40 V
Article number	34847

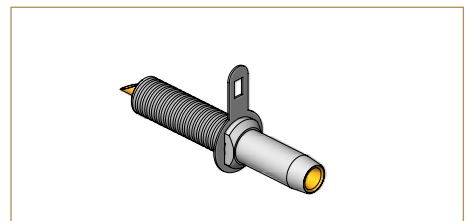

Description	Power DC connector, Ø 2,1
Plug	Two-terminal
Electrical design	Max. 12 V
Article number	35640

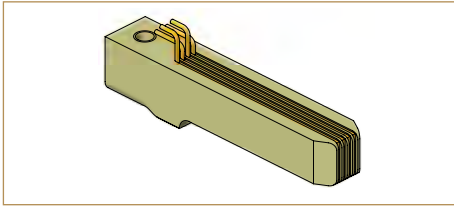

Description	RJ-10 connector
Plug	Four-terminal
Casing material	High performance plastic
Electrical design	Max. 230 V
Article number	17824
Connection cycles	Approx. 200.000

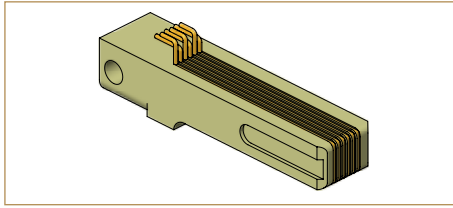

Description	RJ-12 connector
Plug	Six-terminal
Casing material	High performance plastic
Electrical design	Max. 230 V
Article number	17825
Connection cycles	Approx. 100.000

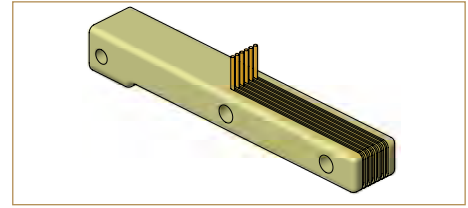

Description	RJ-12 connector, extended L-58 mm
Plug	Six-terminal
Casing material	High performance plastic
Electrical design	Max. 230 V
Article number	35427
Connection cycles	Approx. 200.000

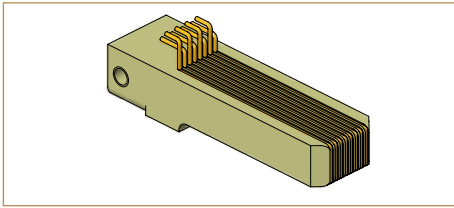

Description	RJ-45 connector
Plug	Eight-terminal
Casing material	High performance plastic
Electrical design	Max. 230 V
Article number	17826
Connection cycles	Approx. 200.000

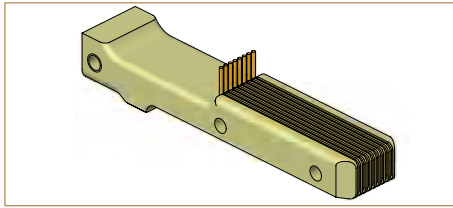

Description	RJ-45 connector extended L-58 mm
Plug	Eight-terminal
Casing material	High performance plastic
Electrical design	Max. 230 V
Article number	35428
Connection cycles	Approx. 200.000

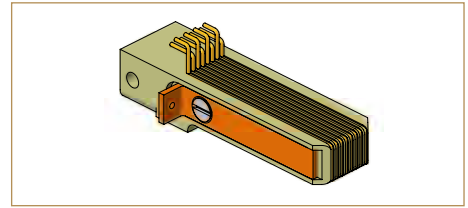

Description	RJ-45 connector with shield check
Plug	Eight-terminal
Casing material	High performance plastic
Electrical design	Max. 230 V
Article number	41164
Connection cycles	Approx. 200.000

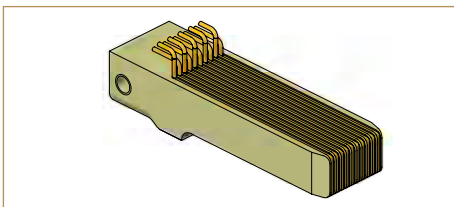

Description	RJ-50 connector
Plug	Ten-terminal
Casing material	High performance plastic
Electrical design	Max. 230 V
Article number	17827
Connection cycles	Approx. 200.000

PSA

Test Plug Mounting

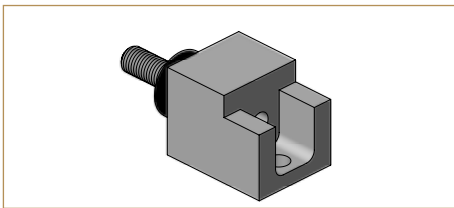

Description	Mounting adapter for four-terminal plug
Article number	17830

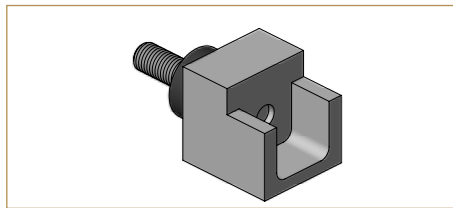

Description	Mounting adapter for six-terminal plug
Article number	18198

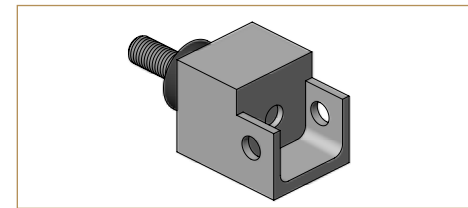

Description	Mounting adapter for ten-terminal plug
Article number	18199

Applied Radio Frequency Technology



The radio frequency probes from INGUN are used especially when radio frequency signals must be measured.

Contacting of MM8030 Switch Connectors

Series MM8030

Connection Dimensions

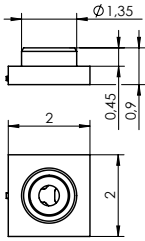

Example:

MM8030 Switch



Contacting of MM8130 / MM8430 Switch Connectors

Series MM8130

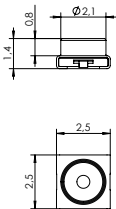

Example:

MM8130 Switch



Series MM8430

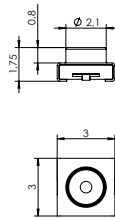

Example:

MM8430 Switch



Contents

MM8030

6 GHz
HFS-823
HFS-856 142

12 GHz
HFS-865 144

MM8130 MM8430

6 GHz
HFS-823
HFS-860, HFS-860 M 145

MS-156 s. Page 147

MS-180 s. Page 150

Pico II s. Page 151
PN 1551372-1

Receptacles (KS) 192 - 194

Spacer of Receptacles (DS) 195

Cable plug assembly (SE) 196 - 199

Tools 200 - 201

Inner Conductor/
Signal Conductor 202 - 204

MMBX /
MMCK / MMMPX
MBX / MCK

SMB / SMC

SMP (X/MAX) /
SMP-L SSMP /
P-SMP

SMA / PC3.5
QMA

BMA / BNC
1.0/2.3

N / FME /
7/16

U.FL / W.FL /
W.FL2 / X.FL /
MM5829

Reverse
SMA / TNC

IEC /
F (75 Ω)

FAKRA /
GT13 / GT16

Digital

Switch
connector
contacting

PCB
test point

PCB test
point side

Coaxial
dipole probe

Accessories

MS-156 (HF) MS-156 C

6 GHz 147
HFS-823
HFS-856
HFS-860, HFS-860 M

MS-180

6 GHz 150
HFS-856

Pico II PN 1551372-1

6 GHz 151
HFS-823

Receptacles (KS) 192 - 194

Spacer of Receptacles (DS) 195

Cable plug assembly (SE) 196 - 199

Tools 200 - 201

Inner Conductor/ Signal Conductor 202 - 204

Contacting of MS-156 (HF) / MS-156 C Switch Connectors

Series MS-156 (HF)

Connection Dimensions

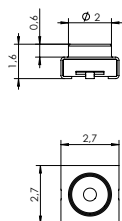

Example:
MS-156 (HF) Switch



Series MS-156 C

Connection Dimensions

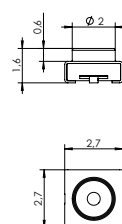

Example:
MS-156 C Switch



Contacting of MS-180 Switch Connectors

Series MS-180

Connection Dimensions

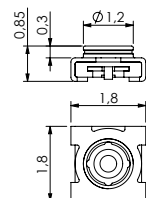

Example:
MS-180 Switch



Contacting of Pico II, PN 1551372-1 Switch Connectors

Series PN 1551372-1

Connection Dimensions

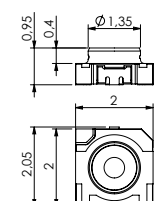

Example:
Pico II, PN 1551372-1 Switch



MM8030 / MM8130 / MM8430 / MS-156 HF / MS-156 C / MS-180 / Pico II, PN 1551372-1 Switch

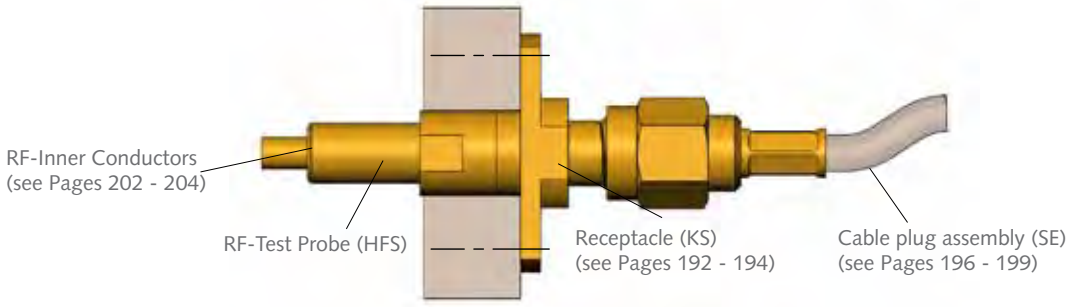

Contacting Example MM8030:

Contacting of MM8030 Switch
HFS-823 305 040 A 6043 MM310



Customizing Example:



Electrical Data

HFS-823	HFS-856
HFS-860 / 860 M	HFS-865
Frequency Range with HFS-856/860:	up to 6 GHz
Frequency Range with HFS-823:	up to 6 GHz
Frequency Range with HFS-865:	up to 12 GHz
Current Rating Outer Conductor:	8–10 A
Current Rating Inner Conductor:	2–3 A
R_i typical Inner Conductor	≤ 10 mΩ
Impedance Test Probe:	50 Ω
Impedance Cable	50 Ω

Operating Temperature Range

–40 up to +80° C

Installation Height in Receptacle	KS-810 (F) KS-410 (F) KS-810 M5-(R/F) KS-410 M5-(R/F)			HAS-810 220 (F) HAS-810 220 740 (F)		without KS
	Variant	*Installation Height HFS in KS				
MM8030 Switch	... MM310	---	---	---	---	21.4 mm
	... MM8030	---	---	---	---	22.4 mm
	... MM1 / ...MM1 M	9.4 mm	10.5 mm	---	---	---
MM8130 MM8430 MS-156 Switch	MM036	---	---	---	---	21.6 mm
	... Y80 / ... Y80 M	11.9 mm	13.0 mm	---	---	---
	... Y82 / ... Y82 M	16.9 mm	18.0 mm	---	---	---
	... MS03	---	---	---	---	18.6 mm
...	... MS06	---	---	---	---	18.6 mm
...	... M156	---	---	---	---	22.7 mm
MS-180 Switch	... MS180	---	---	---	---	22.6 mm
Pico II, PN 1551372-1 Switch	... MM310	---	---	---	---	21.4 mm

Note:

Further details of receptacles with and without flange connection (F) see pages 192 - 194.

Series:

Available
Tip Styles:

Ordering Description:

HFS-823 ...

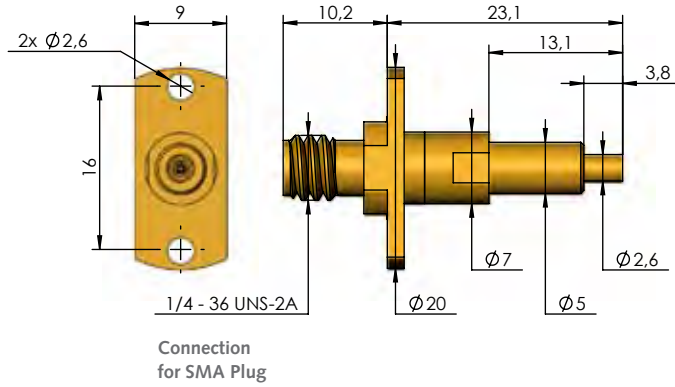

HFS-823 305 040 A **xx** 43 MM310

Note: Version with flange connection. No movement of the connection during stroke movement. Centering range: ± 0.2 mm

Spring force rating

The spring-loaded Inner and Outer Conductor are available with different spring forces. The ordering description is derived by adding up the individual values.

Note:

The RF test probes in the HFS-823 series are positioned and fixed with two screws using a flange connection.

For usage in the case of vibration, shaking, snapping or assembly upside down.

	HFS-823
Spring Force of Inner Conductor (N)	2.0
Spring Force of Outer Conductor (N)	4.0
Character for ordering	60

Mechanical Data

HFS-823

	Outer Cond.	Inner Cond.
Working Stroke:	0.8 mm	0.3 mm
Maximum Stroke:	1.5 mm	1.1 mm

Series:

Available Tip Styles:

Ordering Description:

HFS-856 ...

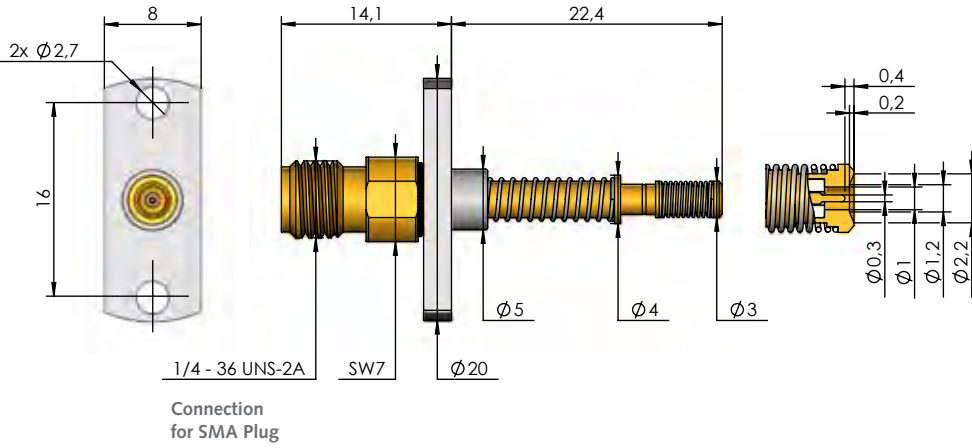

HFS-856 305 030 A **xx** 43 MM8030

Note: The HFS-856 is float-mounted and the connection moves out during the working stroke movement. Compensation of radial positioning inaccuracies of the connector by up to ± 3.0°. Centering range: ± 0.4 mm

Spring force rating

The spring-loaded Inner and Outer Conductor are available with different spring forces. The ordering description is derived by adding up the individual values.

Note:
The RF test probes in the HFS-856 series are positioned and fixed with two screws using a flange connection.

For usage in the case of vibration, shaking, snapping or assembly upside down.

	HFS-856
Spring Force of Inner Conductor (N)	1.5
Spring Force of Outer Conductor (N)	4.0
Character for ordering	55

Mechanical Data

HFS-856	Outer Cond.	Inner Cond.
Working Stroke:	4.2 mm	0.8 mm
Maximum Stroke:	5.2 mm	2.0 mm

Series:



Available
Tip Styles:

Ordering Description:

HFS-865 ...

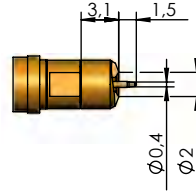
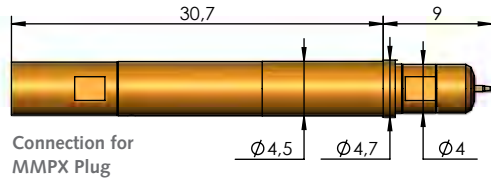

HFS-865 313 050 A **xx** 43 MM1

Note:
Centering range: ± 0.2 mm

Spring force rating

The spring-loaded Outer Conductor are available with different spring forces. The ordering description is derived by adding up the individual values.

	HFS-865		
Spring Force of Inner Conductor (N)	1.3	1.3	1.3
Spring Force of Outer Conductor (N)	4.0	6.0	8.0
Character for ordering	53	73	93

Mechanical Data

HFS-865

	Outer Cond.	Inner Cond.
Working Stroke:	4.0 mm	1.0 mm
Maximum Stroke:	5.0 mm	1.5 mm

Series:

Available
Tip Styles:

Ordering Description:

HFS-823 ...

HFS-823 305 051 A **xx** 43 MM036

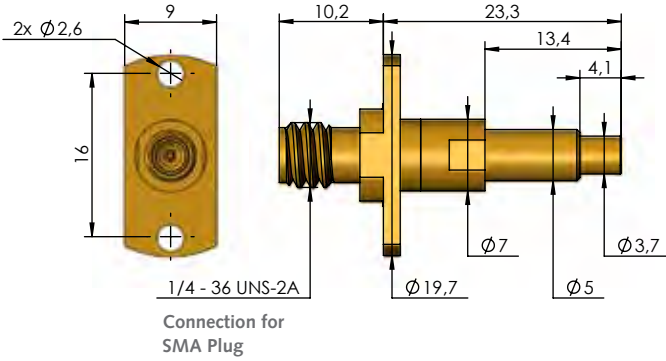

Note: Version with flange connection. No movement of the connection during stroke movement. Centering range: ± 0.3 mm

Spring force rating

The spring-loaded Inner and Outer Conductor are available with different spring forces. The ordering description is derived by adding up the individual values.

Note:
The RF test probes in the HFS-823 series are positioned and fixed with two screws using a flange connection.

For usage in the case of vibration, shaking, snapping or assembly upside down.

	HFS-823
Spring Force of Inner Conductor (N)	2.0
Spring Force of Outer Conductor (N)	4.0
Character for ordering	60

Mechanical Data		
HFS-823		
	Outer Cond.	Inner Cond.
Working Stroke:	1.8 mm	0.3 mm
Maximum Stroke:	3.4 mm	1.1 mm

Series:

Available
Tip Styles:

Ordering Description:

HFS-860 ...

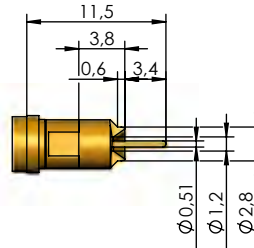
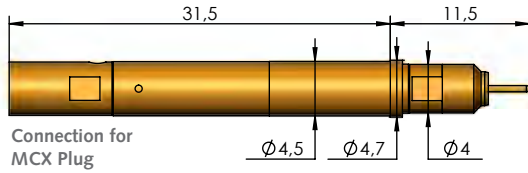

HFS-860 305 051 A **xx** 43 Y80
HFS-860 305 051 A **xx** 43 Y80 M

Note:
Centering range: ± 0.2 mm

HFS-860 ... M (*)

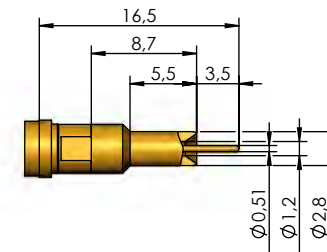
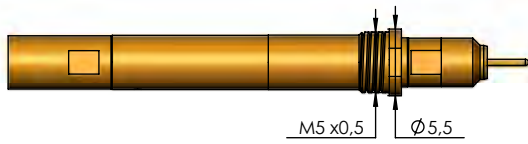

HFS-860 305 051 A **xx** 43 Y82
HFS-860 305 051 A **xx** 43 Y82 M

Note: Version with Installation
Height 16.5 mm for applica-
tions with raised Component
Height and Guide Plate.
Centering range: ± 0.2 mm

Spring force rating

The spring-loaded Inner and Outer Conductor are available with different spring forces. The ordering description is derived by adding up the individual values.

	HFS-860 HFS-860 M			
Spring Force of Inner Conductor (N)	1.3	2.0	1.3	2.0
Spring Force of Outer Conductor (N)	4.0	6.0	8.0	8.0
Character for ordering	53	80	93	99

Note: (*)

For usage in the case of vibration, shaking, snapping or assembly upside down.

Mechanical Data

HFS-860 and HFS-860 M

	Outer Cond.	Inner Cond.
Working Stroke:	4.0 mm	2.0 mm
Maximum Stroke:	5.0 mm	3.7 mm

Series:

Available Tip Styles:

Ordering Description:

HFS-823 ...

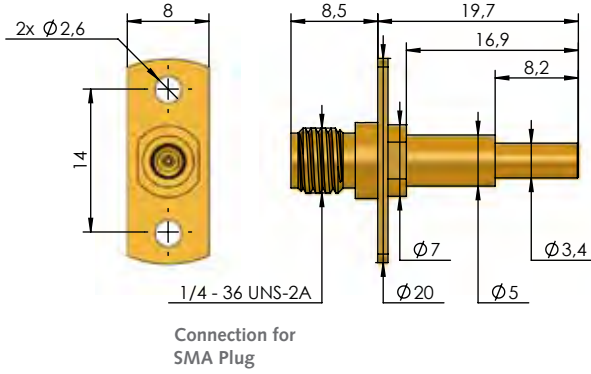

HFS-823 305 051 A **xx** 43 MS03

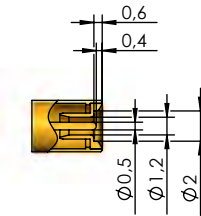

Note: Version with flange connection. No movement of the connection during stroke movement.
Centering range: ± 0.3 mm

HFS-823 ...

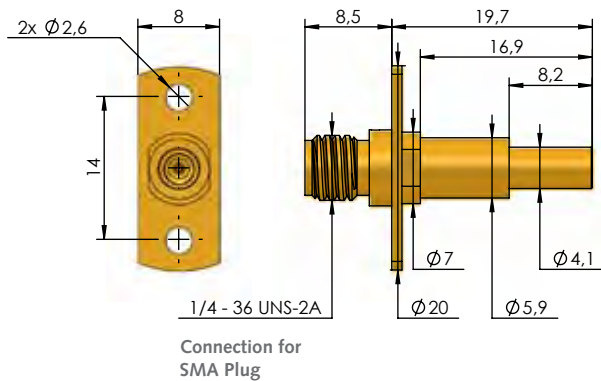

HFS-823 305 051 A **xx** 43 MS06

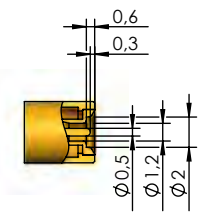

Note: Version with flange connection. No movement of the connection during stroke movement.
Centering range: ± 0.3 mm

Spring force rating

The spring-loaded Inner and Outer Conductor are available with different spring forces. The ordering description is derived by adding up the individual values.

	HFS-823
Spring Force of Inner Conductor (N)	2.0
Spring Force of Outer Conductor (N)	4.0
Character for ordering	60

Note:
The RF test probes in the HFS-823 series are positioned and fixed with two screws using a flange connection.

For usage in the case of vibration, shaking, snapping or assembly upside down.

Mechanical Data	Outer Cond.	Inner Cond.
HFS-823 (MS03)		
Working Stroke:	1.8 mm	0.7 mm
Maximum Stroke:	2.4 mm	1.1 mm

Mechanical Data	Outer Cond.	Inner Cond.
HFS-823 (MS06)		
Working Stroke:	1.7 mm	0.7 mm
Maximum Stroke:	2.3 mm	1.3 mm

Series:



Available
Tip Styles:

Ordering Description:

HFS-856 ...

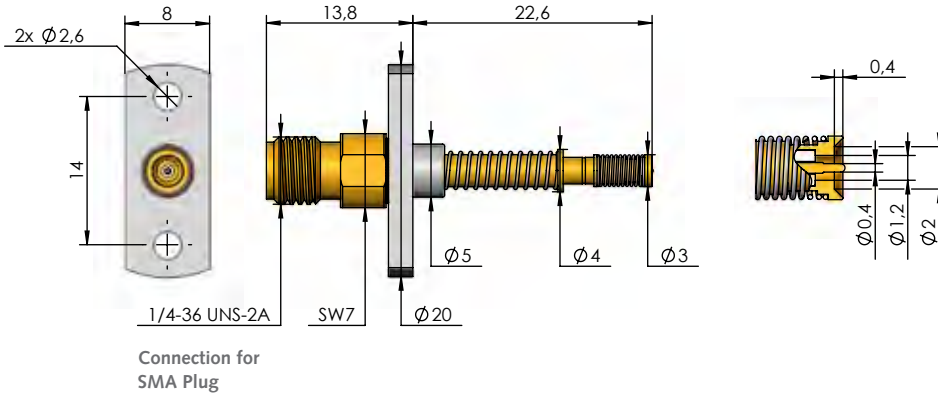

HFS-856 305 040 A **xx** 43 MS156

Note: The HFS-856 is float-mounted and the connection moves out during the working stroke movement. Compensation of radial positioning inaccuracies of the connector by up to ± 3.0°. Centering range: ± 0.3 mm

Spring force rating

The spring-loaded Inner and Outer Conductor are available with different spring forces. The ordering description is derived by adding up the individual values.

Note:

The RF test probes in the HFS-856 series are positioned and fixed with two screws using a flange connection.

For usage in the case of vibration, shaking, snapping or assembly upside down.

	HFS-856
Spring Force of Inner Conductor (N)	1.5
Spring Force of Outer Conductor (N)	4.8
Character for ordering	63

Mechanical Data

HFS-856

	Outer Cond.	Inner Cond.
Working Stroke:	4.2 mm	0.8 mm
Maximum Stroke:	5.2 mm	2.0 mm

Series:

Available Tip Styles:

Ordering Description:

HFS-860 ...

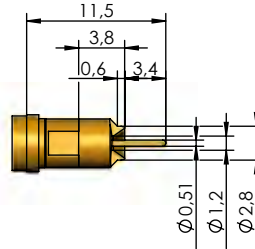
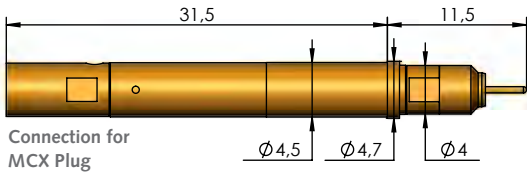

HFS-860 305 051 A **xx** 43 Y80
HFS-860 305 051 A **xx** 43 Y80 M

Note:
Centering range: ± 0.2 mm

HFS-860 ... M (*)

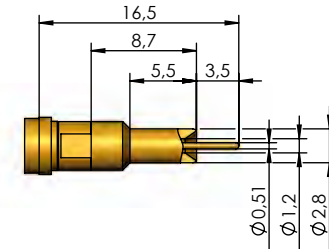
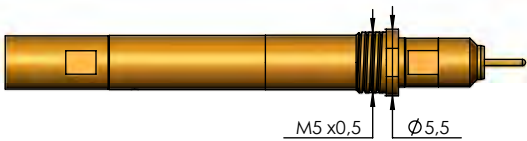

HFS-860 305 051 A **xx** 43 Y82
HFS-860 305 051 A **xx** 43 Y82 M

Note: Version with Installation Height 16.5 mm for applications with raised Component Height and Guide Plate.
Centering range: ± 0.2 mm

Spring force rating

The spring-loaded Inner and Outer Conductor are available with different spring forces. The ordering description is derived by adding up the individual values.

	HFS-860 HFS-860 M			
Spring Force of Inner Conductor (N)	1.3	2.0	1.3	2.0
Spring Force of Outer Conductor (N)	4.0	6.0	8.0	8.0
Character for ordering	53	80	93	99

Mechanical Data

HFS-860 and HFS-860 M

	Outer Cond.	Inner Cond.
Working Stroke:	4.0 mm	2.0 mm
Maximum Stroke:	5.0 mm	3.7 mm

Note: (*)

For usage in the case of vibration, shaking, snapping or assembly upside down.

Series:



Available
Tip Styles:

Ordering Description:

HFS-856 ...

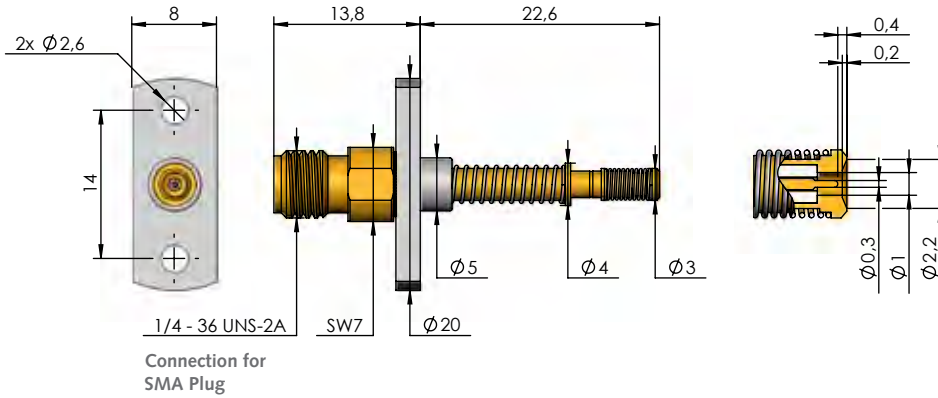

HFS-856 305 030 A **xx** 43 MS180

Note: The HFS-856 is float-mounted and the connection moves out during the working stroke movement. Compensation of radial positioning inaccuracies of the connector by up to $\pm 3,0^\circ$. Centering range: ± 0.4 mm

Spring force rating

The spring-loaded Inner and Outer Conductor are available with different spring forces. The ordering description is derived by adding up the individual values.

Note:

The RF test probes in the HFS-856 series are positioned and fixed with two screws using a flange connection.

For usage in the case of vibration, shaking, snapping or assembly upside down.

	HFS-856
Spring Force of Inner Conductor (N)	1.5
Spring Force of Outer Conductor (N)	4.8
Character for ordering	63

Mechanical Data

HFS-856

	Outer Cond.	Inner Cond.
Working Stroke:	4.2 mm	0.8 mm
Maximum Stroke:	5.4 mm	2.0 mm

Series:

Available Tip Styles:

Ordering Description:

HFS-823 ...

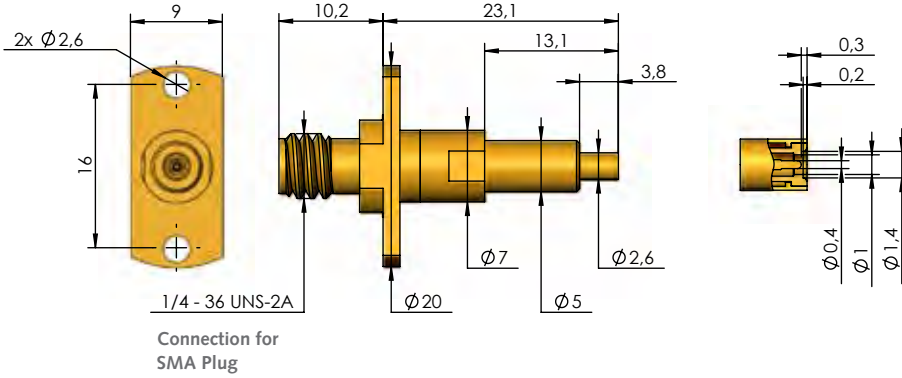

HFS-823 305 040 A **xx** 43 MM310

Note: Version with flange connection. No movement of the connection during stroke movement.
Centering range: ± 0.3 mm

Spring force rating

The spring-loaded Inner and Outer Conductor are available with different spring forces. The ordering description is derived by adding up the individual values.

	HFS-823
Spring Force of Inner Conductor (N)	2.0
Spring Force of Outer Conductor (N)	4.0
Character for ordering	60

Note:
The RF test probes in the HFS-823 series are positioned and fixed with two screws using a flange connection.

For usage in the case of vibration, shaking, snapping or assembly upside down.

Mechanical Data

HFS-823

	Outer Cond.	Inner Cond.
Working Stroke:	0.8 mm	0.3 mm
Maximum Stroke:	1.5 mm	1.1 mm

Applied Radio Frequency Technology



The radio frequency probes from INGUN are used especially when radio frequency signals must be measured.

Contacting of PCB-Layout with closed Ground Ring

Signal guiding to inwards (Multilayer)

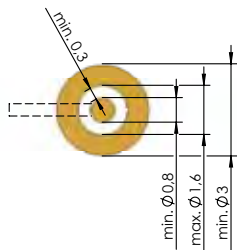

PCB coax closed

Contacting of PCB-Layout with Ground Ring open on one side

Signal guiding outwards

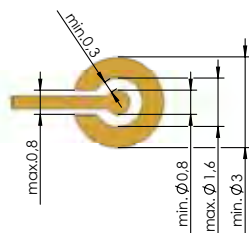

PCB coax open

Contacting of PCB-Layout with kidney-shaped Ground Ring

Through Signal guiding outwards

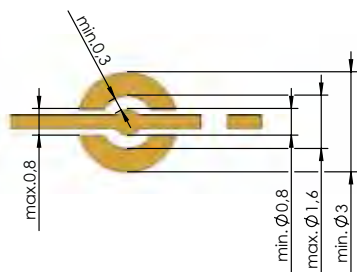

PCB coax kidney-shaped

Contents

PCB coax closed (50 Ω)

2 GHz	156
HFS-810, HFS-810 M	
HFS-410, HFS-410 M	
4 GHz	157
HFS-840, HFS-840 M	
HFS-440, HFS-440 M	

PCB coax open (50 Ω)

2 GHz	158
HFS-810, HFS-810 4M	
HFS-410, HFS-410 4M	
4 GHz	159
HFS-840, HFS-840 4M	
HFS-440, HFS-440 4M	
6 GHz	160
HFS-860, HFS-860 4M	

PCB coax kidney-shaped (50 Ω)

2 GHz	161
HFS-810, HFS-810 4M	
HFS-410, HFS-410 4M	
4 GHz	162
HFS-840, HFS-840 4M	
HFS-440, HFS-440 4M	
6 GHz	163
HFS-860, HFS-860 4M	

Receptacles (KS)	192 - 194
------------------	-----------

Spacer of Receptacles (DS)	195
----------------------------	-----

Cable plug assembly (SE)	196 - 199
--------------------------	-----------

Tools	200 - 201
-------	-----------

Inner Conductor/Signal Conductor	202 - 204
----------------------------------	-----------

MMBX / MMCPX / MMCPX
MMCK / MMMPX
MBX / MCX
SMB / SMC
SMP (X/MAX) / SMP-L 55MP / P-5MP
SMA / PC3.5 QMA
BMA / BNC 1,0/2.3
N / FME / 7/16
U.FL / W.FL / W.FL2 / X.FL / MM5829
Reverse SMA / TNC
IEC / F (75 Ω)
FAKRA / GT13 / GT16
Digital
Switch connector contacting
PCB test point
PCB test point side
Coaxial dipole probe
Accessories

**PCB-SG
PCB-SG-
filter
PCB-GSG
PCB-GGSGG
(50 Ω)**

2 GHz 164
HFS-810, HFS-810 4M
HFS-410, HFS-410 4M

4 GHz 165
HFS-840, HFS-840 4M
HFS-440, HFS-440 4M
HFS-836

12 GHz 166
HFS-837

**PCB coax
closed
(75 Ω)**

1 GHz 179
HFS-858

**PCB coax
open (75 Ω)**

1 GHz 180
HFS-858

Receptacles (KS) 192 - 194

Spacer of Receptacles (DS) 195

Cable plug assembly (SE) 196 - 199

Tools 200 - 201

Inner Conductor/
Signal Conductor 202 - 204

Contacting of PCB-Layout with different levels

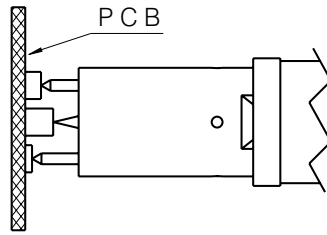

HFS-Variants for PCB-Layouts	Signal (S)	Ground (G)
PCB-SG	1	1
PCB-GSG	1	2
PCB-GGSGG	1	4

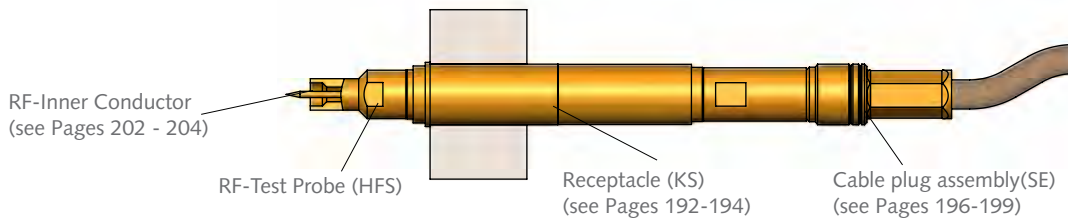

Customizing Example:

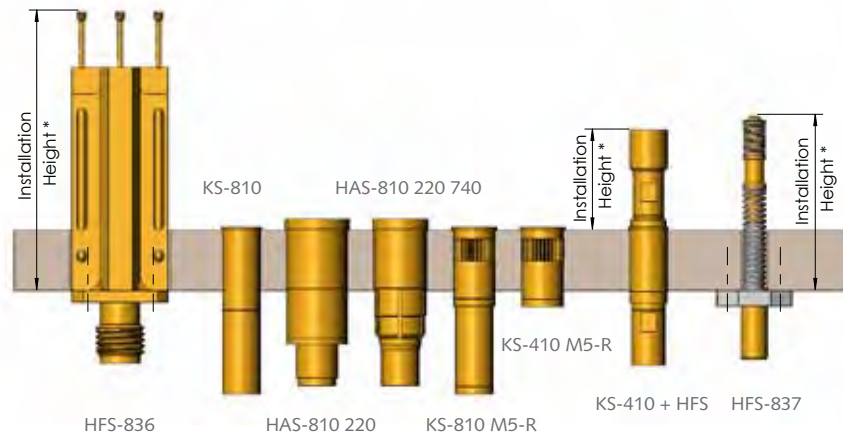

Electrical Data

HFS-810/810 M/810 4M	HFS-840/840 M/840 4M
HFS-410/410 M/410 4M	HFS-440/440 M/440 4M
HFS-836	HFS-837
HFS-858	HFS-860/860 M

Frequency Range with HFS-858:	up to 1 GHz
Frequency Range with HFS-810/410:	up to 2 GHz
Frequency Range with HFS-836/840/440:	up to 4 GHz
Frequency Range with HFS-860:	up to 6 GHz
Frequency Range with HFS-837:	up to 12 GHz
Current Rating Outer Conductor:	8 - 10 A
Current Rating Inner Conductor:	2 - 3 A
R_i typical Inner Conductor:	≤ 10 mΩ
Impedance Test Probe:	50 Ω
	at HFS-858 75 Ω
Impedance Cable:	50 Ω
	at HFS-858 75 Ω

Operating Temperature Range

-40 up to +80° C

Installation Height in Receptacle		KS-810 (F) KS-410 (F) KS-810 M5-(R/F) KS-410 M5-(R/F) KS-858	HAS-810 220 (F) HAS-810 220 740 (F)
Variant		*Installation Height HFS in KS	
PCB coax closed (50 Ω / 75 Ω)	... / ... M	11.9 mm	13.0 mm
PCB coax open (50 Ω / 75 Ω)	... S / ... S 4M	11.9 mm	13.0 mm
PCB coax kidney-shaped (50 Ω)	... P / ... P 4M	11.9 mm	13.0 mm
PCB-SG PCB-SG-Filter PCB-GSG PCB-GSGG		See illustration on product side	

Note:
 Further details of receptacles with and without flange connection (F) see pages 192 - 194.

Series:

Available Tip Styles:

Ordering Description:

HFS-810 ...

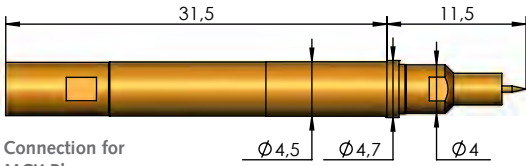

Connection for MCX Plug

HFS-810 ... M (*)

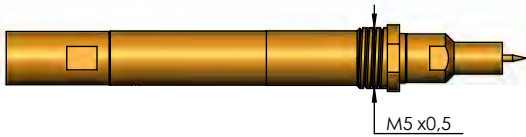

HFS-410 ...

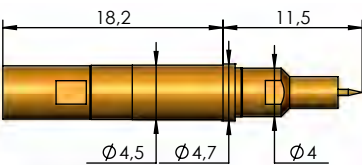

HFS-410 ... M (*)

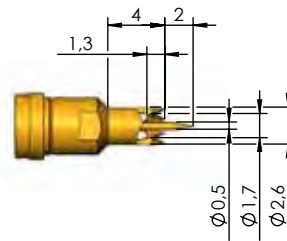
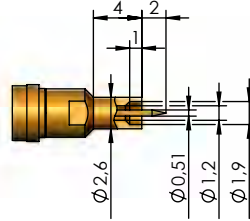
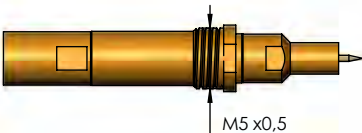

- HFS-810 201 051 A **xx** 02
- HFS-810 201 051 A **xx** 02 M
- HFS-410 201 051 A **xx** 02
- HFS-410 201 051 A **xx** 02 M

Note: To contact closed Ground Rings with signal guiding to the inner side. The tip-style 02 (flat) of the Outer Plunger is only used when contacting clean PC-Boards.

- HFS-810 201 051 A **xx** 06
- HFS-810 201 051 A **xx** 06 M
- HFS-410 201 051 A **xx** 06
- HFS-410 201 051 A **xx** 06 M

Note: To contact closed Ground Rings with signal guiding to the inner side. The tip-style 06 (serrated) of the Outer Plunger is used when contacting contaminated PC-Boards.

Spring force rating

The spring-loaded Inner and Outer Conductor are available with different spring forces. The ordering description is derived by adding up the individual values.

	HFS-810 HFS-810 M				HFS-410 HFS-410 M
Spring Force of Inner Conductor (N)	1.3	2.0	1.3	2.0	1.0
Spring Force of Outer Conductor (N)	4.0	6.0	8.0	8.0	4.0
Character for ordering	53	80	93	99	50

Note: (*)

For usage in the case of vibration, shaking, snapping or assembly upside down.

Mechanical Data

HFS-810 and HFS-810 M

	Outer Cond.	Inner Cond.
Working Stroke:	4.0 mm	2.0 mm
Maximum Stroke:	5.0 mm	3.7 mm

Mechanical Data

HFS-410 and HFS-410 M

	Outer Cond.	Inner Cond.
Working Stroke:	2.0 mm	2.0 mm
Maximum Stroke:	3.0 mm	3.0 mm

Series:

Available
Tip Styles:

Ordering Description:

HFS-840 ...

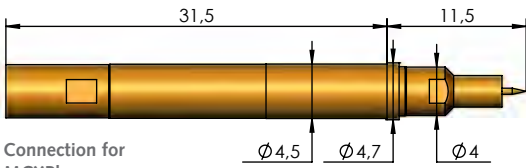

Connection for
MCXPlug

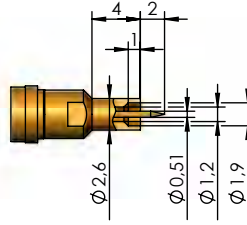

- HFS-840 201 051 A **xx** 02
- HFS-840 201 051 A **xx** 02 M
- HFS-440 201 051 A **xx** 02
- HFS-440 201 051 A **xx** 02 M

Note: To contact closed Ground Rings with signal guiding to the inner side. The tip-style 02 (flat) of the Outer Plunger is only used when contacting clean PC-Boards.

HFS-840 ... M (*)

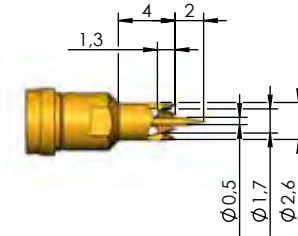
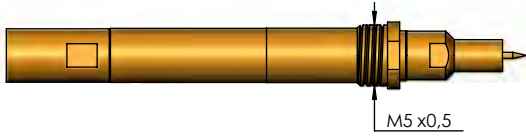

- HFS-840 201 051 A **xx** 06
- HFS-840 201 051 A **xx** 06 M
- HFS-440 201 051 A **xx** 06
- HFS-440 201 051 A **xx** 06 M

Note: To contact closed Ground Rings with signal guiding to the inner side. The tip-style 06 (serrated) of the Outer Plunger is used when contacting contaminated PC-Boards.

HFS-440 ...

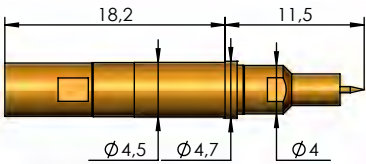

HFS-440 ... M (*)

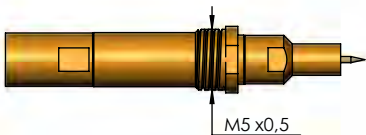

Spring force rating

The spring-loaded Inner and Outer Conductor are available with different spring forces. The ordering description is derived by adding up the individual values.

	HFS-840 HFS-840 M				HFS-440 HFS-440 M
Spring Force of Inner Conductor (N)	1.3	2.0	1.3	2.0	1.0
Spring Force of Outer Conductor (N)	4.0	6.0	8.0	8.0	4.0
Character for ordering	53	80	93	99	50

Mechanical Data

HFS-840 and HFS-840 M

	Outer Cond.	Inner Cond.
Working Stroke:	4.0 mm	2.0 mm
Maximum Stroke:	5.0 mm	3.7 mm

Mechanical Data

HFS-440 and HFS-440 M

	Outer Cond.	Inner Cond.
Working Stroke:	2.0 mm	2.0 mm
Maximum Stroke:	3.0 mm	3.0 mm

Note: (*)

For usage in the case of vibration, shaking, snapping or assembly upside down.

Series:

Available
Tip Styles:

Ordering Description:

HFS-810 ...

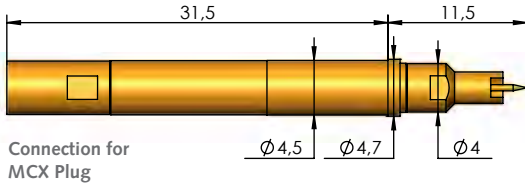

HFS-810 ... 4M (*)

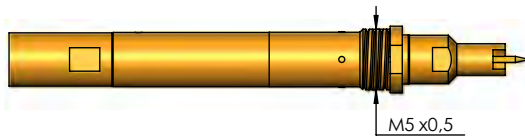

HFS-410 ...

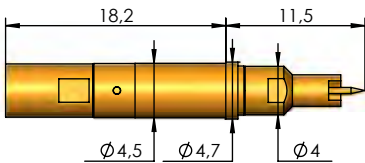

HFS-410 ... 4M (*)

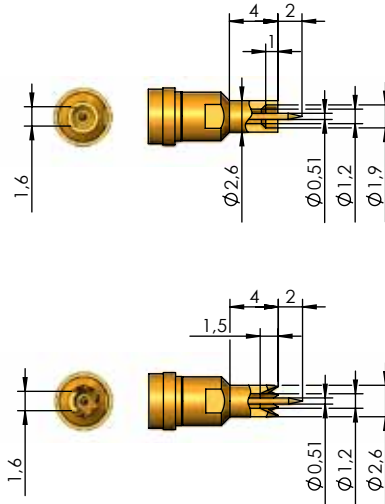
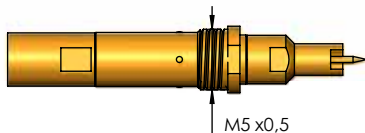

- HFS-810 201 051 A **xx** 02 S
- HFS-810 201 051 A **xx** 02 S 4M
- HFS-410 201 051 A **xx** 02 S
- HFS-410 201 051 A **xx** 02 S 4M

Note: To contact open ground rings with signal guiding to the outer side. The slit tip-style O2 S (flat - slit) of the Outer Plunger is used when contacting clean PC-Boards.

- HFS-810 201 051 A **xx** 06 S
- HFS-810 201 051 A **xx** 06 S 4M
- HFS-410 201 051 A **xx** 06 S
- HFS-410 201 051 A **xx** 06 S 4M

Note: To contact open Ground Rings with signal guiding to the outer side. The slit tip-style O6 S (serrated - slit) of the Outer Plunger is used when contacting contaminated PC-Boards.

Spring force rating

The spring-loaded Inner and Outer Conductor are available with different spring forces. The ordering description is derived by adding up the individual values.

Note: (*)

For usage in the case of vibration, shaking, snapping or assembly upside down.

The "4M" variant has additional securing crimps that prevent rotation of the Test Probe. For applications with Asymmetric Plungers respectively Outer Plungers, that must be assembled in a pre-determined position.

	HFS-810 HFS-810 4M				HFS-410 HFS-410 4M
Spring Force of Inner Conductor (N)	1.3	2.0	1.3	2.0	1.0
Spring Force of Outer Conductor (N)	4.0	6.0	8.0	8.0	4.0
Character for ordering	53	80	93	99	50

Mechanical Data

HFS-810 and HFS-810 4M

	Outer Cond.	Inner Cond.
Working Stroke:	4.0 mm	2.0 mm
Maximum Stroke:	5.0 mm	3.7 mm

Mechanical Data

HFS-410 and HFS-410 4M

	Outer Cond.	Inner Cond.
Working Stroke:	2.0 mm	2.0 mm
Maximum Stroke:	3.0 mm	3.0 mm

Series:

Available
Tip Styles:

Ordering Description:

HFS-860 ...

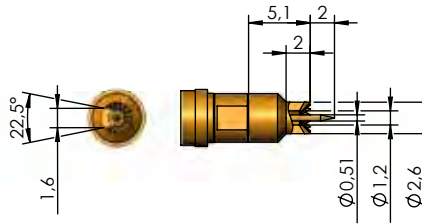
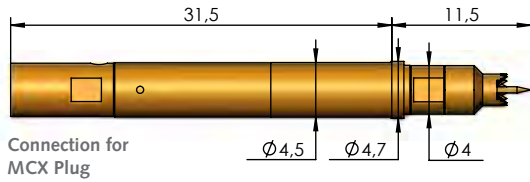

HFS-860 201 051 A **xx** 06 S
HFS-860 201 051 A **xx** 06 S 4M

Note: To contact open Ground Rings with signal guiding to the outer side. The slit tip-style 06 S (serrated - slit) of the Outer Plunger is used when contacting contaminated PC-Boards.

HFS-860 ... 4M (*)

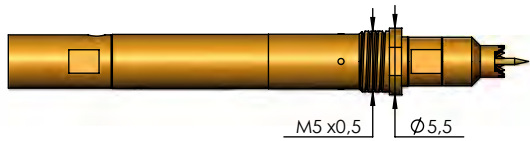

Spring force rating

The spring-loaded Inner and Outer Conductor are available with different spring forces. The ordering description is derived by adding up the individual values.

Note: (*)

For usage in the case of vibration, shaking, snapping or assembly upside down.

The "4M" variant has additional securing crimps that prevent rotation of the pre-determined position of the Test Probe. For applications with Asymmetric Plungers respectively Outer Plungers, that must be assembled in a pre-determined position.

	HFS-860 HFS-860 4M			
Spring Force of Inner Conductor (N)	1.3	2.0	1.3	2.0
Spring Force of Outer Conductor (N)	4.0	6.0	8.0	8.0
Character for ordering	53	80	93	99

Mechanical Data

HFS-860 and HFS-860 M

	Outer Cond.	Inner Cond.
Working Stroke:	4.0 mm	2.0 mm
Maximum Stroke:	5.0 mm	3.7 mm

Series:

Available Tip Styles:

Ordering Description:

HFS-810 ...

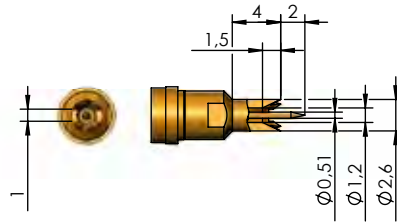
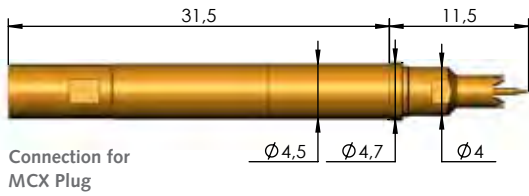

- HFS-810 201 051 A **xx** 06 P
- HFS-810 201 051 A **xx** 06 P 4M
- HFS-410 201 051 A **xx** 06 P
- HFS-410 201 051 A **xx** 06 P 4M

Note: For contacting kidney-shaped Ground Rings with through signal guiding.

HFS-810 ... 4M (*)



HFS-410 ...

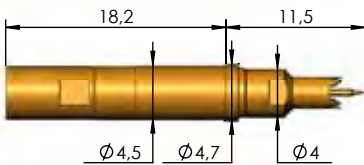

HFS-410 ... 4M (*)

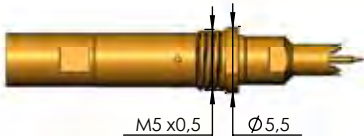

Spring force rating

The spring-loaded Inner and Outer Conductor are available with different spring forces. The ordering description is derived by adding up the individual values.

Note: (*)

For usage in the case of vibration, shaking, snapping or assembly upside down.

The "4M" variant has additional securing crimps that prevent rotation of the pre-determined position of the Test Probe. For applications with Asymmetric Plungers respectively Outer Plungers, that must be assembled in a pre-determined position.

	HFS-810 HFS-810 4M				HFS-410 HFS-410 4M
Spring Force of Inner Conductor (N)	1.3	2.0	1.3	2.0	1.0
Spring Force of Outer Conductor (N)	4.0	6.0	8.0	8.0	4.0
Character for ordering	53	80	93	99	50

Mechanical Data

HFS-810 and HFS-810 4M

	Outer Cond.	Inner Cond.
Working Stroke:	4.0 mm	2.0 mm
Maximum Stroke:	5.0 mm	3.7 mm

Mechanical Data

HFS-410 and HFS-410 4M

	Outer Cond.	Inner Cond.
Working Stroke:	2.0 mm	2.0 mm
Maximum Stroke:	3.0 mm	3.0 mm

Series:

Available
Tip Styles:

Ordering Description:

HFS-840 ...

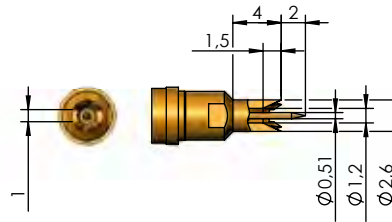
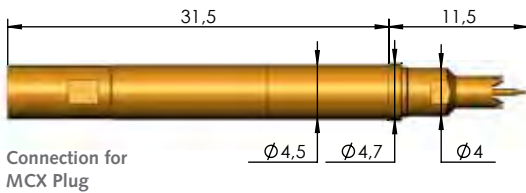

HFS-840 201 051 A **xx** 06 P
HFS-840 201 051 A **xx** 06 P 4M
HFS-440 201 051 A **xx** 06 P
HFS-440 201 051 A **xx** 06 P 4M

Note: For contacting kidney-shaped Ground Rings with through signal guiding.

HFS-840 ... 4M (*)



HFS-440 ...

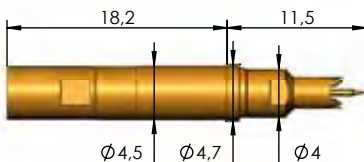

HFS-440 ... 4M (*)

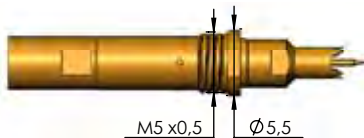

Spring force rating

The spring-loaded Inner and Outer Conductor are available with different spring forces. The ordering description is derived by adding up the individual values.

Note: (*)

For usage in the case of vibration, shaking, snapping or assembly upside down.

The "4M" variant has additional securing crimps that prevent rotation of the pre-determined position of the Test Probe. For applications with Asymmetric Plungers respectively Outer Plungers, that must be assembled in a pre-determined position.

	HFS-840 HFS-840 4M				HFS-440 HFS-440 4M
	1.3	2.0	1.3	2.0	1.0
Spring Force of Inner Conductor (N)	1.3	2.0	1.3	2.0	1.0
Spring Force of Outer Conductor (N)	4.0	6.0	8.0	8.0	4.0
Character for ordering	53	80	93	99	50

Mechanical Data

HFS-840 and HFS-840 4M

	Outer Cond.	Inner Cond.
Working Stroke:	4.0 mm	2.0 mm
Maximum Stroke:	5.0 mm	3.7 mm

Mechanical Data

HFS-440 and HFS-440 4M

	Outer Cond.	Inner Cond.
Working Stroke:	2.0 mm	2.0 mm
Maximum Stroke:	3.0 mm	3.0 mm

Series:

Available Tip Styles:

Ordering Description:

HFS-860 ...

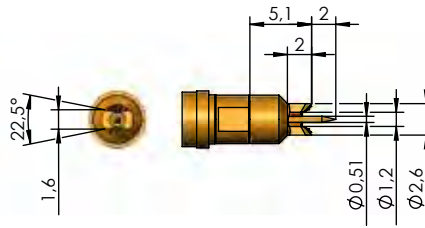
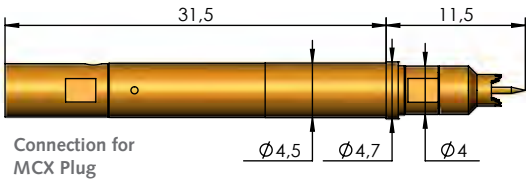

HFS-860 201 051 A **xx** 06 P
HFS-860 201 051 A **xx** 06 P 4M

Note: For contacting kidney-shaped Ground Rings with through signal guiding.

HFS-860 ... 4M (*)

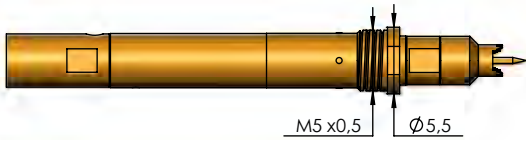

Spring force rating

The spring-loaded Inner and Outer Conductor are available with different spring forces. The ordering description is derived by adding up the individual values.

Note: (*)

For usage in the case of vibration, shaking, snapping or assembly upside down.

The "4M" variant has additional securing crimps that prevent rotation of the pre-determined position of the Test Probe. For applications with Asymmetric Plungers respectively Outer Plungers, that must be assembled in a pre-determined position.

	HFS-860 HFS-860 4M			
Spring Force of Inner Conductor (N)	1.3	2.0	1.3	2.0
Spring Force of Outer Conductor (N)	4.0	6.0	8.0	8.0
Character for ordering	53	80	93	99

Mechanical Data

HFS-860 and HFS-860 4M

	Outer Cond.	Inner Cond.
Working Stroke:	4.0 mm	2.0 mm
Maximum Stroke:	5.0 mm	3.7 mm

Series:

Available
Tip Styles:

Ordering Description:

HFS-810 ...

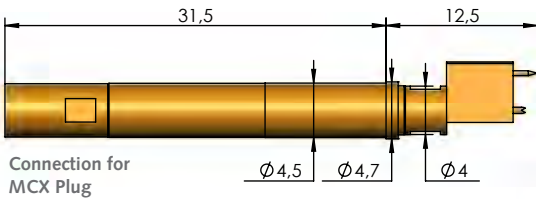

HFS-810 ... 4M (*)



HFS-410 ...

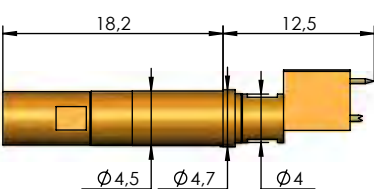

HFS-410 ... 4M (*)

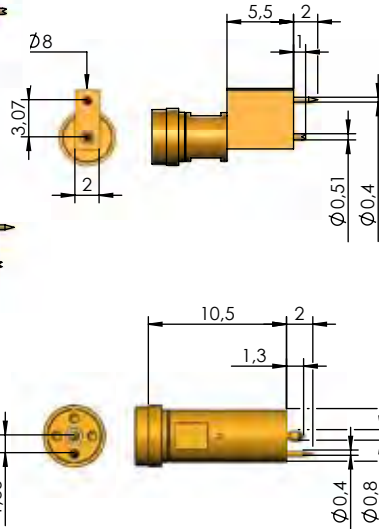
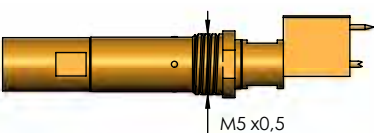

- HFS-810 204 051 A **xx** 02 V1-AS3
- HFS-810 204 051 A **xx** 02 V1-AS3 4M
- HFS-410 204 051 A **xx** 02 V1-AS3
- HFS-410 204 051 A **xx** 02 V1-AS3 4M

Note: (Version 1)
For contacting Ground Pads with different heights. Outer Plunger (Ground) with one spring-loaded tip, (tip-style 01 spear-point), working stroke 1.0 mm, spring force 0.8 N. Width of Outer Plunger 2.0 mm and asymmetric for applications with high component density.

- HFS-810 358 080 A **xx** 02 V2-00S
- HFS-810 358 080 A **xx** 02 V2-00S 4M
- HFS-410 358 080 A **xx** 02 V2-00S
- HFS-410 358 080 A **xx** 02 V2-00S 4M

Note: (Version 2) **
For contacting Ground Pads with different heights. Outer Plunger (Ground) with one spring-loaded tip, (tip-style 01 spear-point), working stroke 1.0 mm, spring force 0.8 N.

Spring force rating

The spring-loaded Outer Conductor are available with different spring forces. The ordering description is derived by adding up the individual values.

	HFS-810 HFS-810 4M		HFS-410 HFS-410 4M	
Spring Force of Inner Conductor (N) (Signal)	Inner conductor not spring-loaded			
Spring Force at working stroke Spring loaded point (Ground) on Outer Conductor Body (N)	0.8	0.8	0.8	0.8
Spring Force of Outer Conductor Body (N)	4.0	6.0	8.0	4.0
Character for ordering	48	68	88	48

Note: (*)

For usage in the case of vibration, shaking, snapping or assembly upside down.

The "4M" variant has additional securing crimps that prevent rotation of the pre-determined position of the Test Probe. For applications with Asymmetric Plungers respectively Outer Plungers, that must be assembled in a pre-determined position.

Mechanical Data

HFS-810 and HFS-810 4M

	Outer Cond. Body	Outer Cond. Point (Ground)	Inner Cond. (Signal)
Working Stroke:	3.5 mm (4.0 mm)**	1.0 mm	not spring-loaded
Max. Stroke:	4.0 mm (5.0 mm)**	1.5 mm	loaded

Mechanical Data

HFS-410 and HFS-410 4M

	Outer Cond. Body	Outer Cond. Point (Ground)	Inner Cond. (Signal)
Working Stroke:	2.0 mm	1.0 mm	not spring-loaded
Maximum Stroke:	3.0 mm	1.5 mm	loaded

Series:

Available Tip Styles:

Ordering Description:

HFS-840 ...

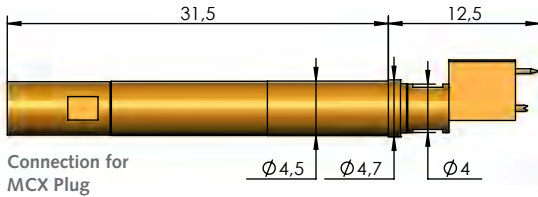

Connection for MCX Plug

HFS-840 ... 4M (*)

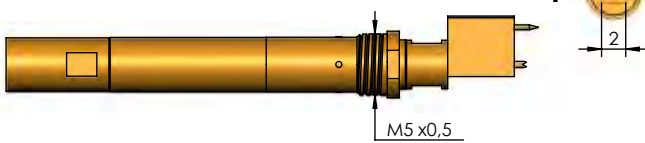

HFS-440 ...

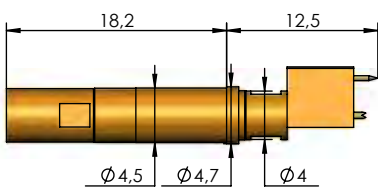

HFS-440 ... 4M (*)

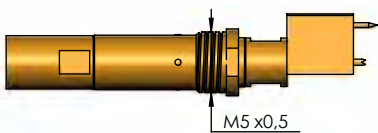

- HFS-840 204 051 A **xx** 02 V1-AS3
- HFS-840 204 051 A **xx** 02 V1-AS3 4M
- HFS-440 204 051 A **xx** 02 V1-AS3
- HFS-440 204 051 A **xx** 02 V1-AS3 4M

Note: (Version 1)
For contacting Ground Pads with different heights. Outer Plunger (Ground) with one spring-loaded tip, (tip-style 01 spear-point), working stroke 1.0 mm, spring force 0.8 N. Width of Outer Plunger 2.0 mm and asymmetric for applications with high component density.

- HFS-840 358 080 A **xx** 02 V2-00S
- HFS-840 358 080 A **xx** 02 V2-00S 4M
- HFS-440 358 080 A **xx** 02 V2-00S
- HFS-440 358 080 A **xx** 02 V2-00S 4M

Note: (Version 2) **
For contacting Ground Pads with different heights. Outer Plunger (Ground) with one spring-loaded tip, (tip-style 01 spear-point), working stroke 1.0 mm, spring force 0.8 N.

Spring force rating

The spring-loaded Outer Conductor are available with different spring forces. The ordering description is derived by adding up the individual values.

Note: (*)

For usage in the case of vibration, shaking, snapping or assembly upside down.

The "4M" variant has additional securing crimps that prevent rotation of the pre-determined position of the Test Probe. For applications with Asymmetric Plungers respectively Outer Plungers, that must be assembled in a pre-determined position.

	HFS-840		HFS-440	
	HFS-840 4M		HFS-440 4M	
Spring Force of Inner Conductor (N) (Signal)	Inner conductor not spring-loaded			
Spring Force at working stroke Spring loaded point (Ground) on Outer Conductor Body (N)	0.8	0.8	0.8	0.8
Spring Force of Outer Conductor Body (N)	4.0	6.0	8.0	4.0
Character for ordering	48	68	88	48

Mechanical Data

HFS-840 and HFS-840 4M

	Outer cond. Body	Outer cond. Point (Ground)	Inner Cond. (Signal)
Working Stroke:	3.5 mm (4.0 mm)**	1.0 mm	not spring-loaded
Max. Stroke :	4.0 mm (5.0 mm)**	1.5 mm	loaded

Mechanical Data

HFS-440 and HFS-440 4M

	Outer cond. Body	Outer cond. Point (Ground)	Inner cond. (Signal)
Working Stroke:	2.0 mm	1.0 mm	not spring-loaded
Maximum Stroke:	3.0 mm	1.5 mm	loaded

Series:



Available Tip Styles:

Ordering Description:

HFS-837 ...

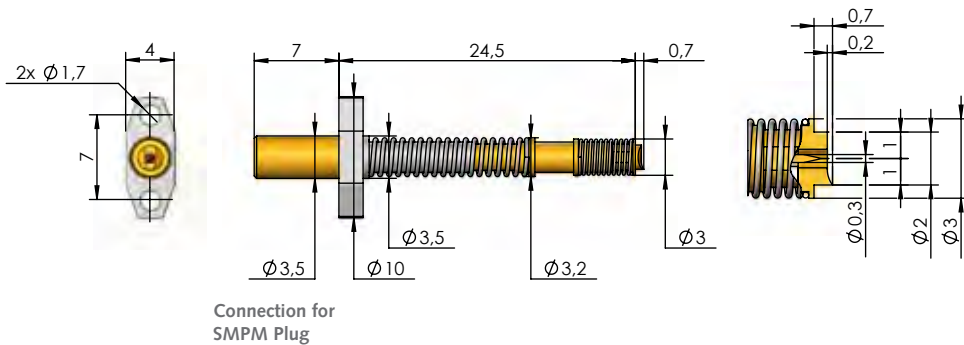

HFS-837 201 030 A **xx** 23 F10

Note: The HFS-837 is non-rotatable and the connection moves out during the working stroke movement. For contacting of the smallest RF test points on PCBs in the pitch distance of 1.0 mm.

Spring force rating

The spring-loaded Outer Conductor are available with different spring forces. The ordering description is derived by adding up the individual values.

	HFS-837
Spring Force of Inner Conductor (N) (Signal)	1.0
Spring Force of Outer Conductor (N) (Ground)	3.8
Character for ordering	48

Note:

The RF test probes in the HFS-837 series are positioned and fixed with two screws using a flange connection.

For use with high packing density.

Mechanical Data

HFS-837

	Outer Cond. (Signal)	Inner Cond. (Ground)
Working Stroke:	4.9 mm	1.0 mm
Maximum Stroke:	5.7 mm	1.5 mm

The Test Probes Catalog



You can find more information about our Test Probes on our homepage www.ingun.com

We will also be pleased to send you our new catalog

The Test Probe Catalog with a large choice of Cable Test Probes

In the new catalog you will find the largest choice of Test Probes: High-current Probes, Fine-pitch Probes, Short-stroke Probes, Interface Probes, Rotating Probes, Switching Probes, Pneumatic Probes and many more.

Apart from this there is a separate section with numerous new Test Probes for Cable Harness Testing – from Screw-in High-current Probes through to Push-back Probes.

RF Probes with Integrated Filter



INGUN RF Probes with an Integrated Filter are generally used when the signal to be measured is picked up directly from the PCB conductor and, if possible, must not be influenced. This is achieved, among other, with an integrated ohmic Resistor near the probe tip, the value of which is derived from an applicable division ratio. A standard division factor of 1/10 is used. Further division factors are available on request.

Due to its mechanical design the INGUN RF probe with its integrated filter can be used for very broad-banded applications. A further advantage in comparison with conventional Oscilloscope Probing Tips is the fact that the ground-connection can be kept as short as possible and therefore parasitic coupling can be reduced to a very low extent. The RF Probe is especially suitable for carrying out automatic tests on PC-Boards using an Oscilloscope.



You can find more information about our RF Products with Integrated Filter on page 169. Further variants can be implemented upon request.

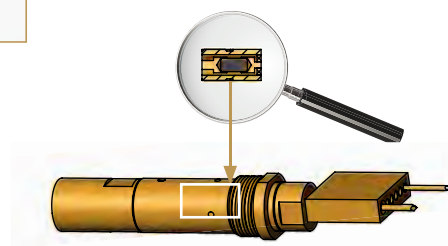

HFS with integrated Filter
Example: HFS-440 007 051 A 4807 P5-AS 4M



Series:

HFS-840 ... with integrated Filter

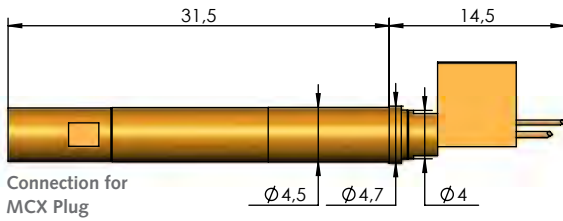

HFS-840 ... 4M (*) with integrated Filter

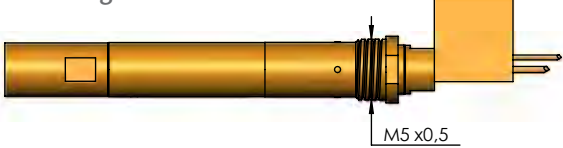

HFS-440 ... with integrated Filter

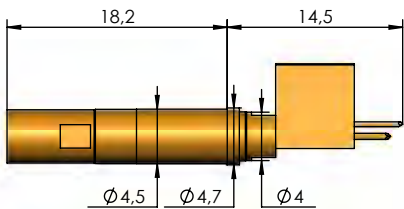

HFS-440 ... 4M (*) with integrated Filter

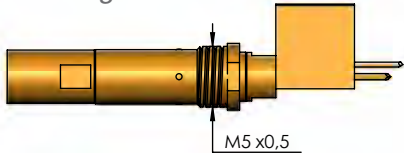

Further variants with Filter can be implemented on request.

Available Tip Styles:

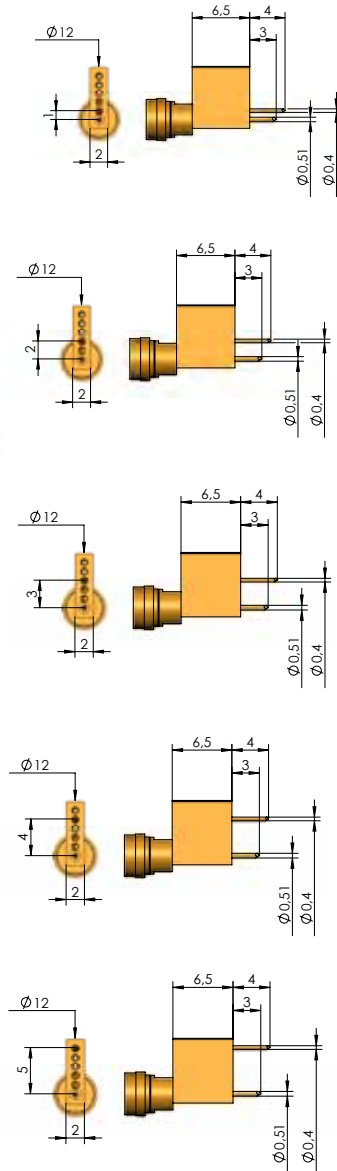

Ordering Description:

HFS-840 007 051 A **xx** 07 P1-AS
HFS-840 007 051 A **xx** 07 P1-AS 4M
HFS-440 007 051 A **xx** 07 P1-AS
HFS-440 007 051 A **xx** 07 P1-AS 4M

Version with 1.0 mm Conductor Pitch

HFS-840 007 051 A **xx** 07 P2-AS
HFS-840 007 051 A **xx** 07 P2-AS 4M
HFS-440 007 051 A **xx** 07 P2-AS
HFS-440 007 051 A **xx** 07 P2-AS 4M

Version with 2.0 mm Conductor Pitch

HFS-840 007 051 A **xx** 07 P3-AS
HFS-840 007 051 A **xx** 07 P3-AS 4M
HFS-440 007 051 A **xx** 07 P3-AS
HFS-440 007 051 A **xx** 07 P3-AS 4M

Version with 3.0 mm Conductor Pitch

HFS-840 007 051 A **xx** 07 P4-AS
HFS-840 007 051 A **xx** 07 P4-AS 4M
HFS-440 007 051 A **xx** 07 P4-AS
HFS-440 007 051 A **xx** 07 P4-AS 4M

Version with 4.0 mm Conductor Pitch

HFS-840 007 051 A **xx** 07 P5-AS
HFS-840 007 051 A **xx** 07 P5-AS 4M
HFS-440 007 051 A **xx** 07 P5-AS
HFS-440 007 051 A **xx** 07 P5-AS 4M

Version with 5.0 mm Conductor Pitch

Spring force rating

The spring-loaded Outer Conductor are available with different spring forces. The ordering description is derived by adding up the individual values.

Note: (*)

For usage in the case of vibration, shaking, snapping or assembly upside down.

The "4M" variant has additional securing crimps that prevent rotation of the pre-determined position of the Test Probe. For applications with Asymmetric Plungers respectively Outer Plungers, that must be assembled in a pre-determined position.

	HFS-840		HFS-440	
	HFS-840 4M		HFS-440 4M	
Spring Force of Inner Conductor (N) (Signal)	Inner conductor not spring-loaded			
Spring Force at working stroke Spring loaded point (Ground) on Outer Conductor Body (N)	0.8	0.8	0.8	0.8
Spring Force of Outer Conductor Body (N)	4.0	6.0	8.0	4.0
Character for ordering	48	68	88	38

Mechanical Data

	HFS-840 and HFS-840 4M		HFS-440 and HFS-440 4M	
	Outer cond. Body	Outer cond. Point (Ground)	Inner Cond. (Signal)	
Working Stroke:	2.0 mm	1.0 mm	not spring-loaded	
Maximum Stroke:	3.0 mm	1.5 mm	loaded	

Series:

Available Tip Styles:

Ordering Description:

HFS-810 ...

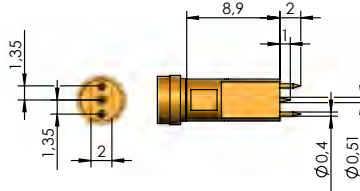
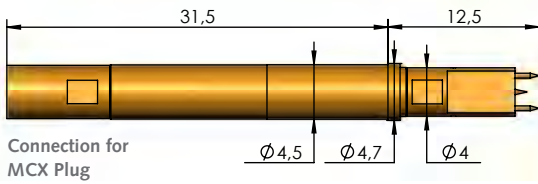

- HFS-810 201 051 A **xx** 29 V2
- HFS-810 201 051 A **xx** 29 V2 4M
- HFS-410 201 051 A **xx** 29 V2
- HFS-410 201 051 A **xx** 29 V2 4M

HFS-810 ... 4M (*)

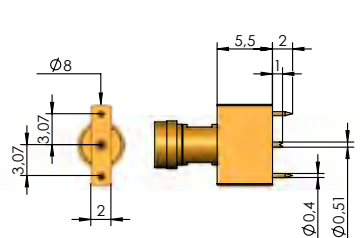

- HFS-810 204 051 A **xx** 29 V2-S2
- HFS-810 204 051 A **xx** 29 V2-S2 4M
- HFS-410 204 051 A **xx** 29 V2-S2
- HFS-410 204 051 A **xx** 29 V2-S2 4M

Note: (Version 1 ** + Version 2)
For contacting ground pads with different heights. Outer Plunger (Ground) with two spring-loaded tip (tip-style 01 spear-point), working stroke 1.0 mm, spring force 0.8 N. Width of Outer Plunger 2.0 mm and asymmetric for applications with high component density.

HFS-410 ...

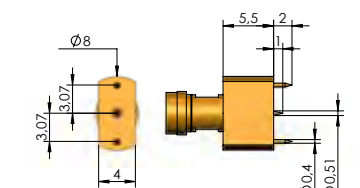
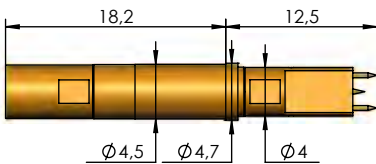

- HFS-810 201 051 A **xx** 29 V2-S1
- HFS-810 201 051 A **xx** 29 V2-S1 4M
- HFS-410 201 051 A **xx** 29 V2-S1
- HFS-410 201 051 A **xx** 29 V2-S1 4M

Note: (Version 3 ***)
For contacting Ground Pads with different heights. Outer Plunger (Ground) with one spring-loaded tip respectively one rigid tip (tip-style 01 spear-point), working stroke 1.0 mm, spring force 0.8 N. Width of Outer Plunger 4.0 mm and asymmetric for applications with high component density.

HFS-410 ... 4M (*)

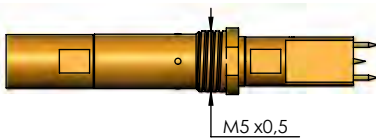

Version 1 + 2	HFS-810 HFS-810 4M		HFS-410 HFS-410 4M
Spring Force of Inner Conductor (N) (Signal)	Inner conductor not spring-loaded		
Spring Force at working stroke Spring loaded point (Ground) on Outer Conductor Body (N)	2 x 0.8	2 x 0.8	2 x 0.8
Spring Force of Outer Conductor Body (N)	6.0	8.0	4.0
Character for ordering	76	96	56

Version 3 ***	HFS-810 HFS-810 4M		HFS-410 HFS-410 4M	
Spring Force of Inner Conductor (N) (Signal)	Inner conductor not spring-loaded			
Spring Force at working stroke Spring loaded point (Ground) on Outer Conductor Body (N)	0.8	0.8	0.8	0.8
Spring Force of Outer Conductor Body (N)	4.0	6.0	8.0	4.0
Character for ordering	48	68	88	48

Note: (*)
For usage in the case of vibration, shaking, snapping or assembly upside down.

The "4M" variant has additional securing crimps that prevent rotation of the pre-determined position of the Test Probe. For applications with Asymmetric Plungers respectively Outer Plungers, that must be assembled in a pre-determined position.

Mechanical Data
HFS-810 and HFS-810 4M

	Outer cond. Body	Outer cond. Point (Ground)	Inner cond. (Signal)
Working Stroke:	3.5 mm (4.0 mm)**	1.0 mm	not spring-loaded
Max. Stroke :	4.0 mm (5.0 mm)**	1.5 mm	loaded

Mechanical Data
HFS-410 and HFS-410 4M

	Outer cond. Body	Outer cond. Point (Ground)	Inner cond. (Signal)
Working Stroke:	2.0 mm	1.0 mm	not spring-loaded
Maximum Stroke:	3.0 mm	1.5 mm	loaded

Series:

Available Tip Styles:

Ordering Description:

HFS-810 ...

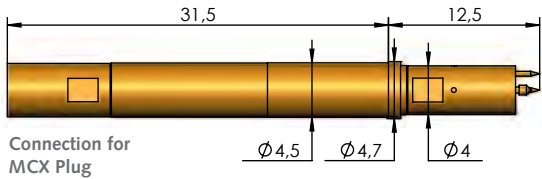

HFS-810 ... 4M (*)



HFS-410 ...

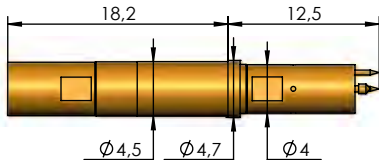

HFS-410 ... 4M (*)

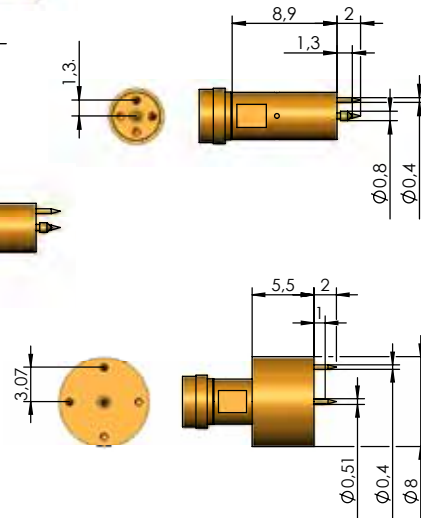
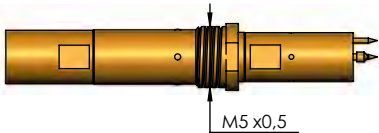

- HFS-810 358 080 A **xx** 02 V2-09S
- HFS-810 358 080 A **xx** 02 V2-09S 4M
- HFS-410 358 080 A **xx** 02 V2-09S
- HFS-410 358 080 A **xx** 02 V2-09S 4M

Note: (Version 1 **) For contacting Ground Pads with different heights. Outer Plunger (Ground) with two spring-loaded tips, 90° off-set, tip-style 01, spear-point, working stroke 1.0 mm, spring force 0.8 N.

- HFS-810 204 051 A **xx** 02 V2
- HFS-810 204 051 A **xx** 02 V2 4M
- HFS-410 204 051 A **xx** 02 V2
- HFS-410 204 051 A **xx** 02 V2 4M

Note: (Version 2) For contacting Ground Pads with different heights. Outer Plunger (Ground) with two spring-loaded tips, 90° off-set, tip-style 01, spear-point, working stroke 1.0 mm, spring force 0.8 N.

Spring force rating

The spring-loaded Outer Conductor are available with different spring forces. The ordering description is derived by adding up the individual values.

Note: (*)

For usage in the case of vibration, shaking, snapping or assembly upside down.

The "4M" variant has additional securing crimps that prevent rotation of the pre-determined position of the Test Probe. For applications with Asymmetric Plungers respectively Outer Plungers, that must be assembled in a pre-determined position.

	HFS-810 HFS-810 4M	HFS-410 HFS-410 4M
Spring Force of Inner Conductor (N) (Signal)	Inner conductor not spring-loaded	
Spring Force at working stroke Spring loaded point (Ground) on Outer Conductor Body (N)	2 x 0.8	2 x 0.8
Federkraft bei Arbeitshub Außenleiter Grundkörper (N)	6.0	8.0
Character for ordering	76	56

Mechanical Data

HFS-810 and HFS-810 4M

	Outer cond. Body	Outer cond. Point (Ground)	Inner cond. (Signal)
Working Stroke:	3.5 mm (4.0 mm)**	1.0 mm	not spring-loaded
Max. Stroke :	4.0 mm (5.0 mm)**	1.5 mm	

Mechanical Data

HFS-410 and HFS-410 4M

	Outer cond. Body	Outer cond. Point (Ground)	Inner cond. (Signal)
Working Stroke:	2.0 mm	1.0 mm	not spring-loaded
Maximum Stroke:	3.0 mm	1.5 mm	

Series:

Available Tip Styles:

Ordering Description:

HFS-840 ...

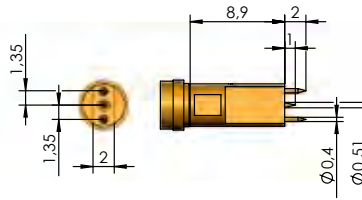
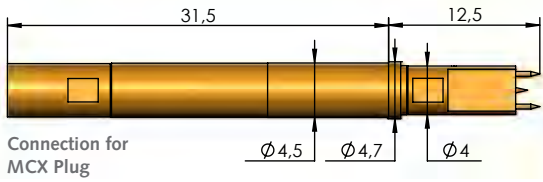

- HFS-840 201 051 A **xx** 29 V2
- HFS-840 201 051 A **xx** 29 V2 4M
- HFS-440 201 051 A **xx** 29 V2
- HFS-440 201 051 A **xx** 29 V2 4M

- HFS-840 204 051 A **xx** 29 V2-S2
- HFS-840 204 051 A **xx** 29 V2-S2 4M
- HFS-440 204 051 A **xx** 29 V2-S2
- HFS-440 204 051 A **xx** 29 V2-S2 4M

HFS-840 ... 4M (*)

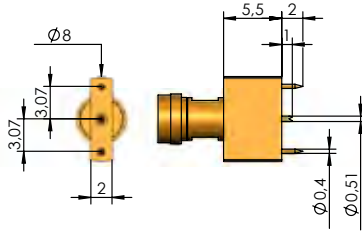
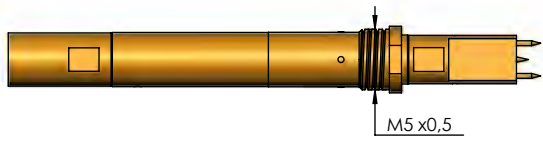

Note: (Version 1 ** + Version 2)
For contacting ground pads with different heights. Outer Plunger (Ground) with two spring-loaded tip (tip-style 01 spear-point), working stroke 1.0 mm, spring force 0.8 N. Width of Outer Plunger 2.0 mm and asymmetric for applications with high component density.

HFS-440 ...

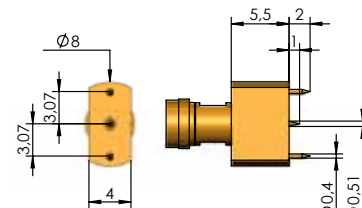
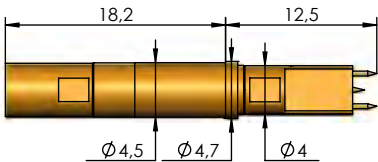

- HFS-840 201 051 A **xx** 29 V2-S1
- HFS-840 201 051 A **xx** 29 V2-S1 4M
- HFS-440 201 051 A **xx** 29 V2-S1
- HFS-440 201 051 A **xx** 29 V2-S1 4M

HFS-440 ... 4M (*)

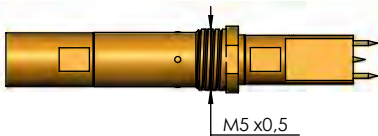

Note: (Version 3 ***)
For contacting Ground Pads with different heights. Outer Plunger (Ground) with one spring-loaded tip respectively one rigid tip (tip-style 01 spear-point), working stroke 1.0 mm, spring force 0.8 N. Width of Outer Plunger 4.0 mm and asymmetric for applications with high component density.

Version 1 + 2	HFS-840 HFS-840 4M	HFS-440 HFS-440 4M
Spring Force of Inner Conductor (N) (Signal)	Inner conductor not spring-loaded	
Spring Force at working stroke Spring loaded point (Ground) on Outer Conductor Body (N)	2 x 0.8	2 x 0.8
Spring Force of Outer Conductor Body (N)	6.0	8.0
Character for ordering	76	56

Version 3 ***	HFS-840 HFS-840 4M	HFS-440 HFS-440 4M
Spring Force of Inner Conductor (N) (Signal)	Inner conductor not spring-loaded	
Spring Force at working stroke Spring loaded point (Ground) on Outer Conductor Body (N)	0.8	0.8
Spring Force of Outer Conductor Body (N)	4.0	6.0
Character for ordering	48	48

Note: (*)
For usage in the case of vibration, shaking, snapping or assembly upside down.

The "4M" variant has additional securing crimps that prevent rotation of the pre-determined position of the Test Probe. For applications with Asymmetric Plungers respectively Outer Plungers, that must be assembled in a pre-determined position.

Mechanical Data
HFS-840 and HFS-840 4M

	Outer cond. Body	Outer cond. Point (Ground)	Inner cond. (Signal)
Working Stroke:	3.5 mm (4.0 mm)**	1.0 mm	not spring-loaded
Max. Stroke :	4.0 mm (5.0 mm)**	1.5 mm	loaded

Mechanical Data
HFS-440 and HFS-440 4M

	Outer cond. Body	Outer cond. Point (Ground)	Inner cond. (Signal)
Working Stroke:	2.0 mm	1.0 mm	not spring-loaded
Maximum Stroke:	3.0 mm	1.5 mm	loaded

Series:

Available Tip Styles:

Ordering Description:

HFS-836 ...

HFS-836 288 120 A **xx** 88 A51F50L

Note: The HFS-836 is characterised by a robust design and the quick, easy exchange of inner and outer conductor.
Pitch distance: 5.1 mm

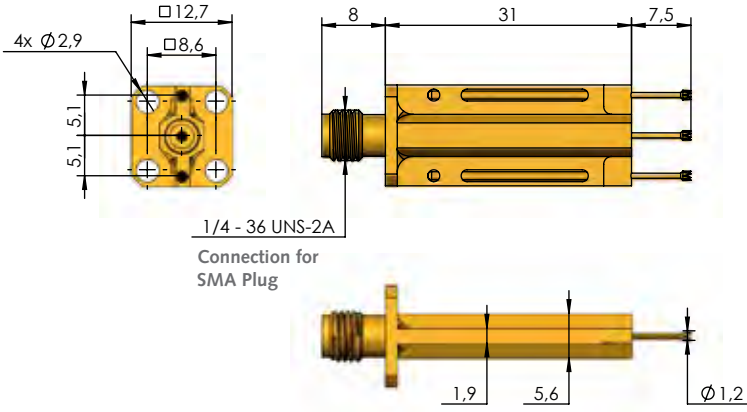

Spring force rating

The spring-loaded Outer Conductor are available with different spring forces. The ordering description is derived by adding up the individual values.

	HFS-836
Spring Force of Inner Conductor (N) (Signal)	1.5
Spring Force of Outer Conductor (N) (Ground)	2 x 1.5
Character for ordering	45

Note:
The RF test probes in the HFS-836 series are positioned and fixed with two screws using a flange connection.

For use with high packing density.

Mechanical Data

HFS-836

	Outer Cond. (Signal)	Inner Cond. (Ground)
Working Stroke:	4.3 mm	4.3 mm
Maximum Stroke:	6.2 mm	6.2 mm

Series:

Available
Tip Styles:

Ordering Description:

HFS-840 ...

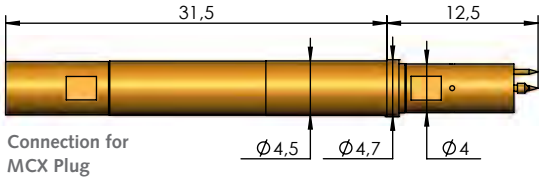

HFS-840 ... 4M (*)



HFS-440 ...

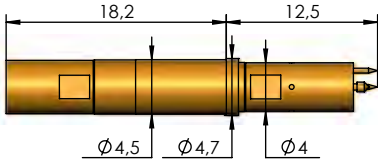

HFS-440 ... 4M (*)

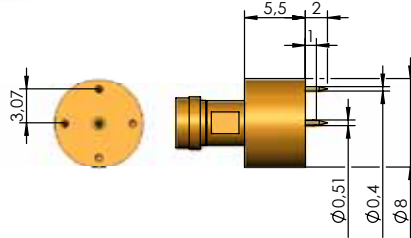
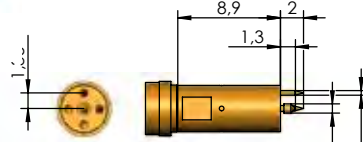
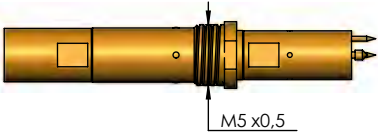

- HFS-840 358 080 A **xx** 02 V2-09S
- HFS-840 358 080 A **xx** 02 V2-09S 4M
- HFS-440 358 080 A **xx** 02 V2-09S
- HFS-440 358 080 A **xx** 02 V2-09S 4M

Note: (Version 1 **)

For contacting Ground Pads with different heights. Outer Plunger (Ground) with two spring-loaded tips, 90° off-set, tip-style 01, spear-point, working stroke 1.0 mm, spring force 0.8 N.

- HFS-840 204 051 A **xx** 02 V2
- HFS-840 204 051 A **xx** 02 V2 4M
- HFS-440 204 051 A **xx** 02 V2
- HFS-440 204 051 A **xx** 02 V2 4M

Note: (Version 2)

For contacting Ground Pads with different heights. Outer Plunger (Ground) with two spring-loaded tips, 90° off-set, tip-style 01, spear-point, working stroke 1.0 mm, spring force 0.8 N.

Spring force rating

The spring-loaded Outer Conductor are available with different spring forces. The ordering description is derived by adding up the individual values.

Note: (*)

For usage in the case of vibration, shaking, snapping or assembly upside down.

The "4M" variant has additional securing crimps that prevent rotation of the pre-determined position of the Test Probe. For applications with Asymmetric Plungers respectively Outer Plungers, that must be assembled in a pre-determined position.

	HFS-840 HFS-840 4M		HFS-440 HFS-440 4M
Spring Force of Inner Conductor (N) (Signal)	Inner conductor not spring-loaded		
Spring Force at working stroke Spring loaded point (Ground) on Outer Conductor Body (N)	2 x 0.8	2 x 0.8	2 x 0.8
Spring Force of Outer Conductor Body (N)	6.0	8.0	4.0
Character for ordering	76	96	56

Mechanical Data

HFS-840 and HFS-840 4M

	Outer cond. Body	Outer cond. Point (Ground)	Inner cond. (Signal)
Working Stroke:	3.5 mm (4,0 mm)**	1.0 mm	not spring-loaded
Max. Stroke:	4.0 mm (5,0 mm)**	1.5 mm	loaded

Mechanical Data

HFS-440 and HFS-440 4M

	Outer cond. Body	Outer cond. Point (Ground)	Inner cond. (Signal)
Working Stroke:	2.0 mm	1.0 mm	not spring-loaded
Maximum Stroke:	3.0 mm	1.5 mm	loaded

Series:

Available Tip Styles:

Ordering Description:

HFS-836 ...

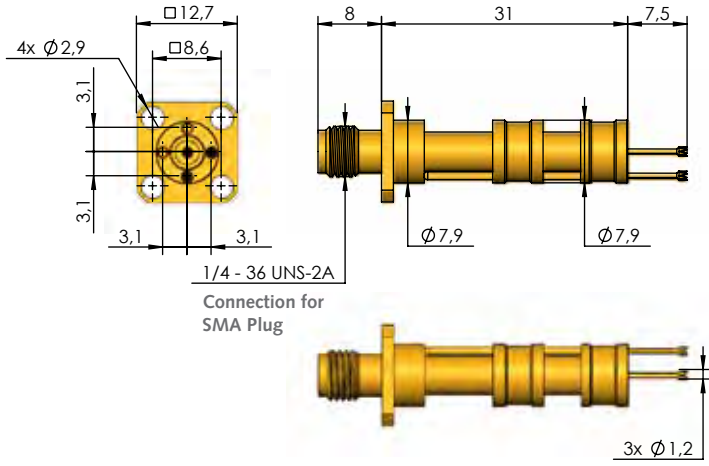

HFS-836 288 120 A **xx** 88 A51R50L

Note: The HFS-836 is characterised by a robust design and the quick, easy exchange of inner and outer conductor. Pitch distance: 3.05 mm

Spring force rating

The spring-loaded Outer Conductor are available with different spring forces. The ordering description is derived by adding up the individual values.

	HFS-836
Spring Force of Inner Conductor (N) (Signal)	1.5
Spring Force of Outer Conductor (N) (Ground)	2 x 1.5
Character for ordering	45

Note:
The RF test probes in the HFS-836 series are positioned and fixed with two screws using a flange connection.

For use with high packing density.

Mechanical Data

HFS-836

	Outer Cond. (Signal)	Inner Cond. (Ground)
Working Stroke:	4.3 mm	4.3 mm
Maximum Stroke:	6.2 mm	6.2 mm

Series:

Available
Tip Styles:

Ordering Description:

HFS-837 ...

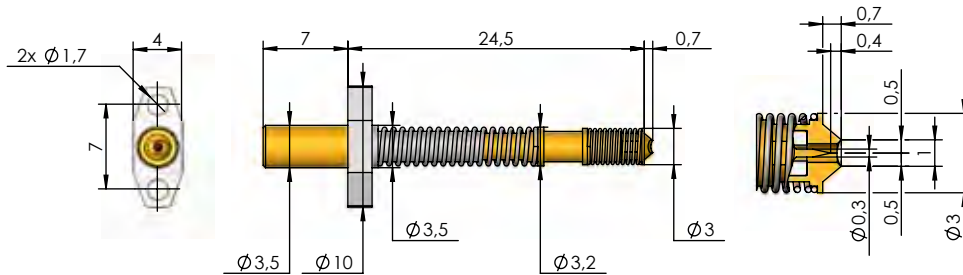

Connection for
SMPM Plug

HFS-837 201 030 A **xx** 23 F05

Note: The HFS-837 is non-rotatable and the connection moves out during the working stroke movement. For contacting of the smallest RF test points on PCBs in the pitch distance of 0.5 mm.

Spring force rating

The spring-loaded Outer Conductor are available with different spring forces. The ordering description is derived by adding up the individual values.

	HFS-837
Spring Force of Inner Conductor (N) (Signal)	1.0
Spring Force of Outer Conductor (N) (Ground)	3.8
Character for ordering	48

Note:

The RF test probes in the HFS-837 series are positioned and fixed with two screws using a flange connection.

For use with high packing density.

Mechanical Data

HFS-837

	Outer Cond. (Signal)	Inner Cond. (Ground)
Working Stroke:	4.9 mm	1.0 mm
Maximum Stroke:	5.7 mm	1.5 mm

Series:

Available Tip Styles:

Ordering Description:

HFS-810 ...

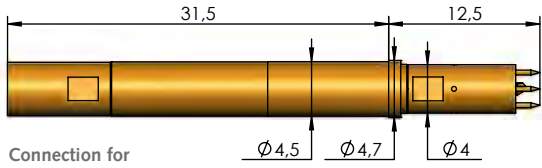

Connection for MCX Plug

HFS-810 ... 4M (*)

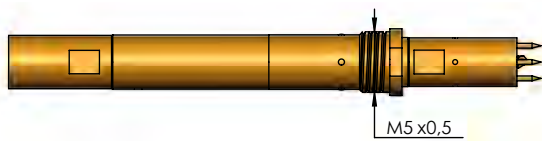

HFS-410 ...

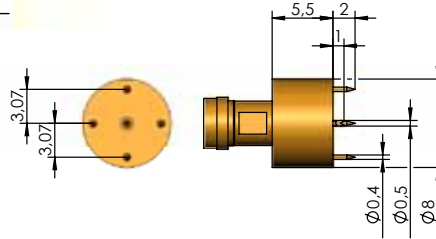
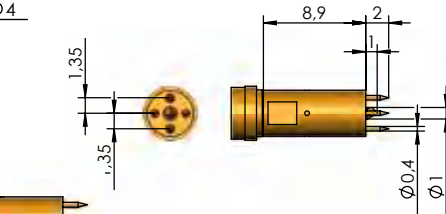
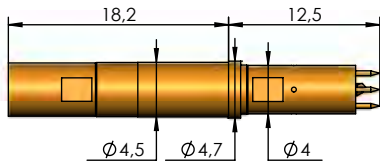

- HFS-810 307 100 A **xx** 02 V2-36S
- HFS-810 307 100 A **xx** 02 V2-36S 4M
- HFS-410 307 100 A **xx** 02 V2-36S
- HFS-410 307 100 A **xx** 02 V2-36S 4M

Note: (Version 1 **)

For contacting Ground Pads with different heights. Outer Plunger (Ground) with four spring-loaded tips, tip-style 01, working stroke 1.0 mm, spring force 0.8 N.

- HFS-810 204 051 A **xx** 02 V2-360
- HFS-810 204 051 A **xx** 02 V2-360 4M
- HFS-410 204 051 A **xx** 02 V2-360
- HFS-410 204 051 A **xx** 02 V2-360 4M

Note: (Version 2)

For contacting Ground Pads with different heights. Outer Plunger (Ground) with four spring-loaded tips, tip-style 01, working stroke 1.0 mm, spring force 0.8 N.

HFS-410 ... 4M (*)

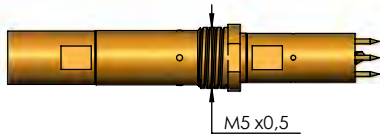

	HFS-810 HFS-810 4M	HFS-410 HFS-410 4M
Spring Force of Inner Conductor (N) (Signal)	Inner conductor not spring-loaded	
Spring Force at working stroke Spring loaded point (Ground) on Outer Conductor Body (N)	4 x 0.8	4 x 0.8
Spring Force of Outer Conductor Body (N)	6.0	8.0
Character for ordering	92	72

Spring force rating

The spring-loaded Outer Conductor are available with different spring forces. The ordering description is derived by adding up the individual values.

Note: (*)

For usage in the case of vibration, shaking, snapping or assembly upside down.

The "4M" variant has additional securing crimps that prevent rotation of the pre-determined position of the Test Probe. For applications with Asymmetric Plungers respectively Outer Plungers, that must be assembled in a pre-determined position.

Mechanical Data

HFS-810 and HFS-810 4M

	Outer cond. Body	Outer cond. Point (Ground)	Inner cond. (Signal)
Working Stroke:	3.5 mm (4.0 mm)**	1.0 mm	not spring-loaded
Max. Stroke:	4.0 mm (5.0 mm)**	1.5 mm	loaded

Mechanical Data

HFS-410 and HFS-410 4M

	Outer cond. Body	Outer cond. Point (Ground)	Inner cond. (Signal)
Working Stroke:	2.0 mm	1.0 mm	not spring-loaded
Maximum Stroke:	3.0 mm	1.5 mm	loaded

Series:

Available
Tip Styles:

Ordering Description:

HFS-840 ...

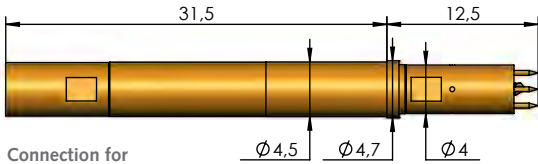

Connection for
MCX Plug

HFS-840 ... 4M (*)

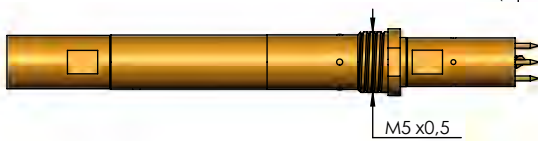

HFS-440 ...

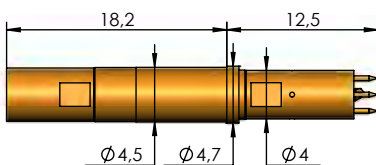

HFS-440 ... 4M (*)

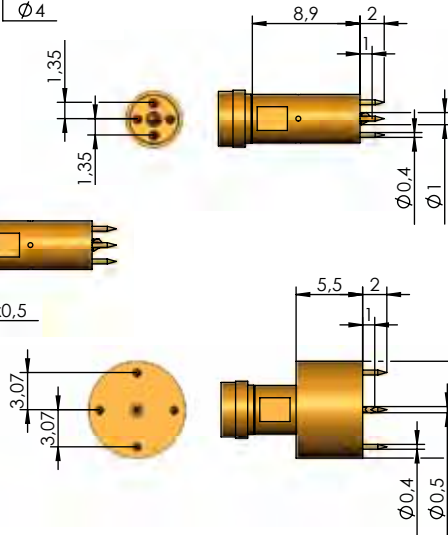
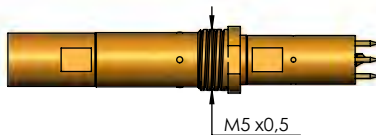

- HFS-840 307 100 A **xx** 02 V2-36S
- HFS-840 307 100 A **xx** 02 V2-36S 4M
- HFS-440 307 100 A **xx** 02 V2-36S
- HFS-440 307 100 A **xx** 02 V2-36S 4M

Note: (Version 1 **) For contacting Ground Pads with different heights. Outer Plunger (Ground) with four spring-loaded tips, tip-style 01, working stroke 1.0 mm, spring force 0.8 N.

- HFS-840 204 051 A **xx** 02 V2-360
- HFS-840 204 051 A **xx** 02 V2-360 4M
- HFS-440 204 051 A **xx** 02 V2-360
- HFS-440 204 051 A **xx** 02 V2-360 4M

Note: (Version 2) For contacting Ground Pads with different heights. Outer Plunger (Ground) with four spring-loaded tips, tip-style 01, working stroke 1.0 mm, spring force 0.8 N.

Spring force rating

The spring-loaded Outer Conductor are available with different spring forces. The ordering description is derived by adding up the individual values.

Note: (*)
For usage in the case of vibration, shaking, snapping or assembly upside down.

The "4M" variant has additional securing crimps that prevent rotation of the pre-determined position of the Test Probe. For applications with Asymmetric Plungers respectively Outer Plungers, that must be assembled in a pre-determined position.

	HFS-840 HFS-840 4M		HFS-440 HFS-440 4M
Spring Force of Inner Conductor (N) (Signal)	Inner conductor not spring-loaded		
Spring Force at working stroke Spring loaded point (Ground) on Outer Conductor Body (N)	4 x 0.8	4 x 0.8	4 x 0.8
Spring Force of Outer Conductor Body (N)	6.0	8.0	4.0
Character for ordering	92	11	72

Mechanical Data

HFS-840 and HFS-840 4M

	Outer cond. Body	Outer cond. Point (Ground)	Inner cond. (Signal)
Working Stroke:	3.5 mm (4.0 mm)**	1.0 mm	not spring-loaded
Max. Stroke:	4.0 mm (5.0 mm)**	1.5 mm	loaded

Mechanical Data

HFS-440 and HFS-440 4M

	Outer cond. Body	Outer cond. Point (Ground)	Inner cond. (Signal)
Working Stroke:	2.0 mm	1.0 mm	not spring-loaded
Maximum Stroke:	3.0 mm	1.5 mm	loaded

Series:

HFS-858 ...

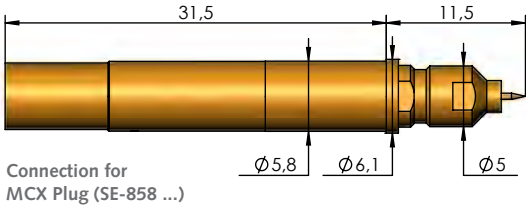

Available Tip Styles:

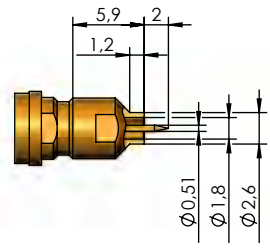

Ordering Description:

HFS-858 201 051 A **xx** 02

Note: For contacting closed Ground Rings with signal guiding inwards. The Outer Plunger tip-style 02 (flat) is only used for contacting clean PC-Boards.

Spring force rating

The spring-loaded Outer Conductor are available with different spring forces. The ordering description is derived by adding up the individual values.

	HFS-858
Spring Force of Inner Conductor (N)	1.3
Spring Force of Outer Conductor (N)	4.0
Character for ordering	53

Mechanical Data

HFS-858

	Outer Cond.	Inner Cond
Working Stroke:	4.0 mm	2.0 mm
Maximum Stroke:	5.0 mm	3.7 mm

MMBX / MMCPX / MMBX / MCX
SMB / SMC
SMP (X/MAX) / SMP-L 55MP / P-5MP
SMA / PC3.5 QMA
BMA / BNC 1,0/2,3
N / FME / 7/16
U.FL / W.FL / W.FL2 / X.FL / MM5829
Reverse SMA / TNC
IEC / F (75 Ω)
FAKRA / GT13 / GT16
Digital
Switch connector contacting
PCB test point
PCB test point side
Coaxial dipole probe
Accessories

Series:

Available
Tip Styles:

Ordering Description:

HFS-858 ...

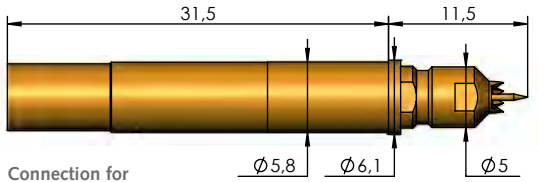

Connection for
MCX Plug (SE-858 ...)

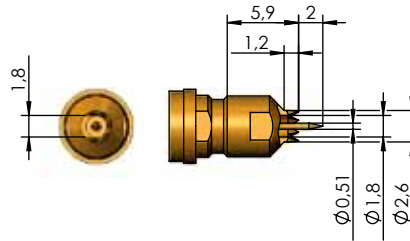

HFS-858 201 051 A **xx** 06 S

Note: For contacting open Ground Rings with signal guiding inwards. The slit tip-style 06 S (slit serrated) of the Outer Plunger is used for contacting contaminated PC-Boards.

Spring force rating

The spring-loaded Outer Conductor are available with different spring forces. The ordering description is derived by adding up the individual values.

	HFS-858
Spring Force of Inner Conductor (N)	1.3
Spring Force of Outer Conductor (N)	4.0
Character for ordering	53

Mechanical Data

HFS-858

	Outer Cond.	Inner Cond
Working Stroke:	4.0 mm	2.0 mm
Maximum Stroke:	5.0 mm	3.7 mm

Contacting of PCB's from the side

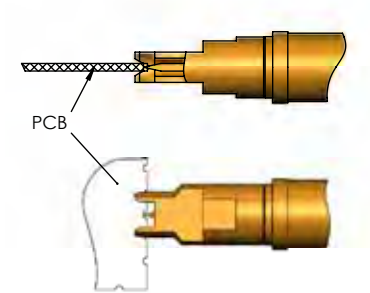
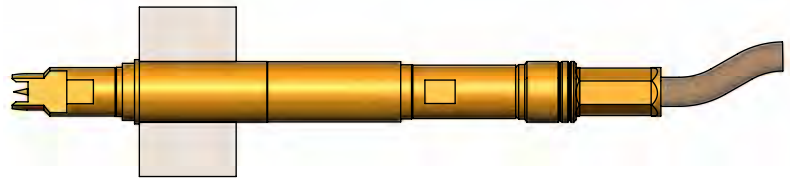

Contents

PCB-side

2 GHz 183 - 184
HFS-810, HFS-810 4M
HFS-410, HFS-410 4M

4 GHz 183 - 184
HFS-840, HFS-840 4M
HFS-440, HFS-440 4M

Receptacles (KS) 192 - 194

Spacer of Receptacles (DS) 195

Cable plug assembly (SE) 196 - 199

Tools 200 - 201

Inner Conductor/
Signal Conductor 202 - 204

MMBX /
MMCK / MMMPX
MBX / MCK

SMB / SMC

SMP (X/MAX)
SMP-L 5SMP /
P-5MP

SMA / PC3.5
QMA

BMA / BNC
1.0/2.3

N / FME /
7/16

U.FL / W.FL /
W.FL2 / X.FL /
MM5829

Reverse
SMA / TNC

IEC /
F (75 Ω)

FAKRA /
GT13 / GT16

Digital

Switch
connector
contacting

PCB
test point

PCB test
point side

Coaxial
dipole probe

Accessories

PCB-side

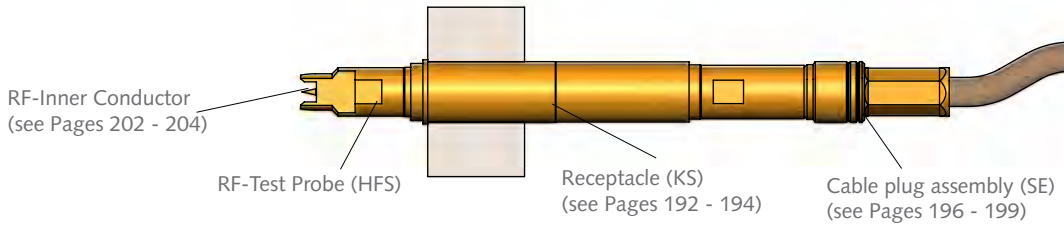

Contacting Example PCB-side:

Contacting of PCB's from the side
HFS-810 201 051 A 5314 VZ

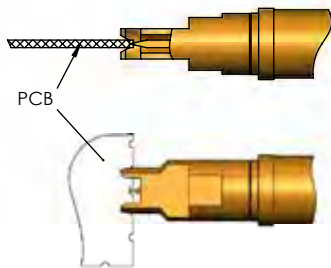

Contacting of PCB's from the side
HFS-810 201 051 A 7629-V2-VZ

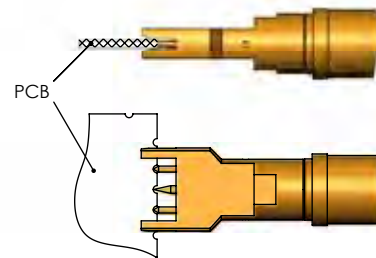

Customizing Example:

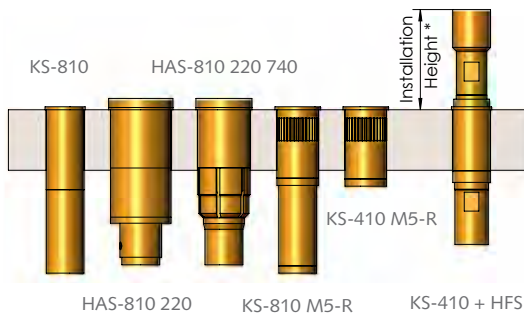

Installation Height in Receptacle		KS-810 (F) KS-410 (F) KS-810 M5-(R/F) KS-410 M5-(R/F)	HAS-810 220 (F) HAS-810 220 740 (F)
Variant		Installation Height HFS in KS	
PCB-Seite	... VZ / ... VZ 4M	10.5 mm	11.6 mm
PCB-Seite	... V2-VZ / ... V2-VZ 4 M	12.7 mm	13.8 mm

Electrical Data

HFS-810 / 810 4M HFS-840 / 840 4M

HFS-410 / 410 4M HFS-440 / 440 4M

Frequency Range with HFS-810/410: up to 2 GHz

Frequency Range with HFS-840/440: up to 4 GHz

Current Rating Outer Conductor: 8–10 A

Current Rating Inner Conductor: 2–3 A

R_i typical Inner Conductor: ≤ 10 mΩ

Impedance Test Probe: 50 Ω

Impedance Cable: 50 Ω

Operating Temperature Range

–40 up to +80° C

Note:

Further details of receptacles with and without flange connection (F) see pages 192 - 194.

Series:

Available Tip Styles:

Ordering Description:

HFS-810 ... / HFS-840 ...

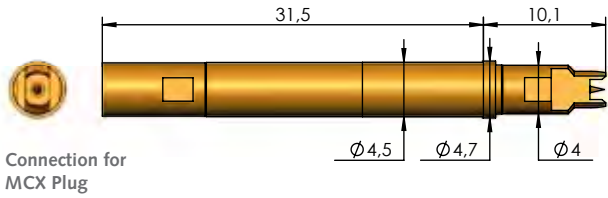

HFS-810 ... 4M / HFS-840 ... 4M (*)



HFS-410 ... / HFS-440 ...

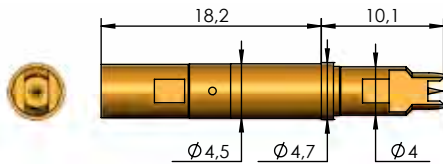

HFS-410 ... 4M / HFS-440 ... 4M (*)

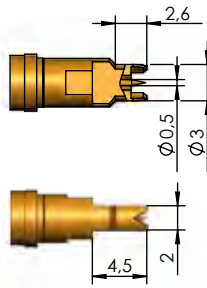
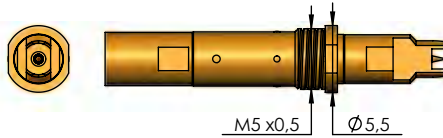

2 GHz

- HFS-810 201 051 A **xx** 14 VZ
- HFS-810 201 051 A **xx** 14 VZ 4M
- HFS-410 201 051 A **xx** 14 VZ
- HFS-410 201 051 A **xx** 14 VZ 4M

4 GHz

- HFS-840 201 051 A **xx** 14 VZ
- HFS-840 201 051 A **xx** 14 VZ 4M
- HFS-440 201 051 A **xx** 14 VZ
- HFS-440 201 051 A **xx** 14 VZ 4M

Note: Version with spring-loaded Inner Conductor (Signal). The pre-centering of the PC-Board is achieved via the geometry of the Outer Conductor. Recommended PCB thickness: 0.5 mm.

Further versions for contacting PC-Boards from the side (when their thickness varies) on request.

Spring force rating

The spring-loaded Inner and Outer Conductor are available with different spring forces. The ordering description is derived by adding up the individual values.

Note: (*)

For usage in the case of vibration, shaking, snapping or assembly upside down.

The "4M" variant has additional securing crimps that prevent rotation of the pre-determined position of the Test Probe. For applications with Asymmetric Plungers respectively Outer Plungers, that must be assembled in a pre-determined position.

	HFS-810/840 HFS-810 4M/840 4M			HFS-410/440 HFS-410 4M/440 4M
Spring Force of Inner Conductor Signal (N)	1.3	1.3	1.3	1.0
Spring Force of Outer Conductor Body (N)	4.0	6.0	8.0	4.0
Character for ordering	53	73	93	50

Mechanical Data

HFS-810/840 and HFS-810 4M/840 4M

	Outer Cond.	Inner Cond.
Working Stroke:	4.0 mm	0.5 mm
Maximum Stroke:	5.0 mm	2.2 mm

Mechanical Data

HFS-410/440 and HFS-410 4M/440 4M

	Outer Cond.	Inner Cond.
Working Stroke:	2.0 mm	0.5 mm
Maximum Stroke:	3.0 mm	1.5 mm



Series:

Available
Tip Styles:

Ordering Description:

HFS-810 ... / HFS-840 ...

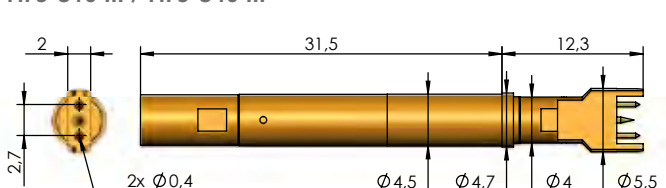

Connection for
MCX Plug

HFS-810 ... 4M / HFS-840 ... 4M (*)

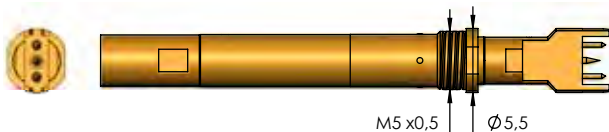

HFS-410 ... / HFS-440 ...

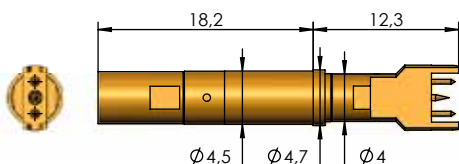

HFS-410 ... 4M / HFS-440 ... 4M (*)

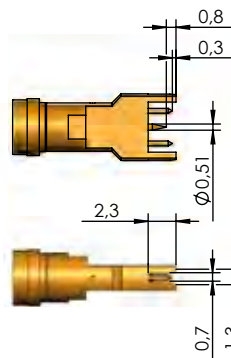
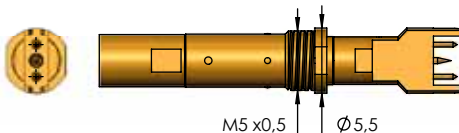

2 GHz

HFS-810 201 051 A **xx** 29 V2-VZ
HFS-810 201 051 A **xx** 29 V2-VZ 4M
HFS-410 201 051 A **xx** 29 V2-VZ
HFS-410 201 051 A **xx** 29 V2-VZ 4M

4 GHz

HFS-840 201 051 A **xx** 29 V2-VZ
HFS-840 201 051 A **xx** 29 V2-VZ 4M
HFS-440 201 051 A **xx** 29 V2-VZ
HFS-440 201 051 A **xx** 29 V2-VZ 4M

Note: Version with spring-loaded Inner Conductor (Signal) and two spring-loaded Ground Contacts. The pre-centering of the PC-Board is achieved via the geometry of the Outer Conductor. Recommended PCB thickness: 0.6 mm.

Further versions for contacting PC-Boards from the side when their thickness and the pitch of the contacting pads vary on request.

Spring force rating

The spring-loaded Outer Conductor are available with different spring forces. The ordering description is derived by adding up the individual values.

	HFS-810/840 HFS-810 4M/840 4M		HFS-410/440 HFS-410 4M/440 4M
Spring Force of Inner Conductor (N) (Signal)	Inner conductor not spring-loaded		
Spring Force at working stroke Spring loaded point (Ground) on Outer Conductor Body (N)	2 x 0.8	2 x 0.8	2 x 0.8
Federkraft bei Arbeitshub Außenleiter Grundkörper (N)	6.0	8.0	4.0
Character for ordering	76	96	56

Note: (*)

For usage in the case of vibration, shaking, snapping or assembly upside down.

The "4M" variant has additional securing crimps that prevent rotation of the pre-determined position of the Test Probe. For applications with Asymmetric Plungers respectively Outer Plungers, that must be assembled in a pre-determined position.

Mechanical Data

	HFS-810 and HFS-810 4M	HFS-840 and HFS-840 4M	
	Outer cond. Body	Outer cond. Point (Ground)	Inner cond. (Signal)
Working Stroke:	4.0 mm	0.5 mm	not spring-loaded
Maximum Stroke:	5.0 mm	1.0 mm	

Mechanische Daten

	HFS-410 and HFS-410 4M	HFS-440 and HFS-440 4M	
	Outer cond. Body	Outer cond. Point (Ground)	Inner cond. (Signal)
Working Stroke:	2.0 mm	0.5 mm	not spring-loaded
Maximum Stroke:	3.0 mm	1.0 mm	

Contacting of PCB's with coaxial di-pole Probe

Series coaxial di-pole Probe HFS-010

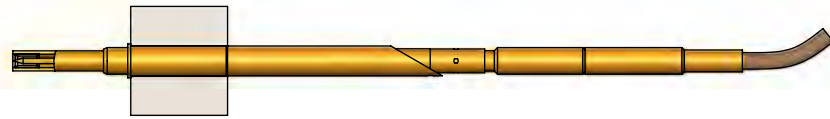

Contacting of PCB's with coaxial di-pole Probe

Series coaxial di-pole Probe HFS-110

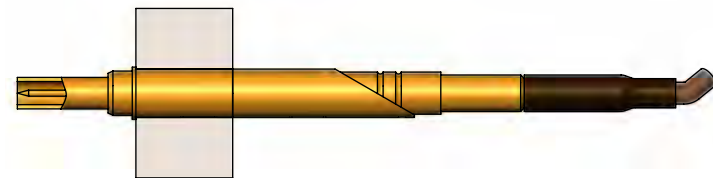

Contacting of PCB's with coaxial di-pole Probe

Series coaxial di-pole Probe DPS-215 M



Contacting of PCB's with coaxial di-pole Probe

Series coaxial di-pole Probe DPS-465 M

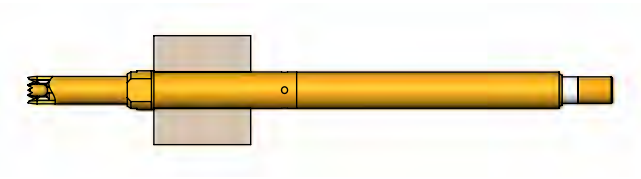

All specifications are subject to change without prior notification

Contents

Coaxial di-pole Probe HFS-010

HFS-010 187

Coaxial di-pole Probe HFS-110

HFS-110 188

Coaxial di-pole Probe DPS-215 M

DPS-215 M 189

Coaxial di-pole Probe DPS-465 M

DPS-465 M 190

Receptacles (KS) 192 - 194

Spacer of Receptacles (DS) 195

Cable plug assembly (SE) 196 - 199

Tools 200 - 201

Inner Conductor/ Signal Conductor 202 - 204

MMBX / MMCPX / MBX / MCB
SMB / SMC
SMP (X/MAX) / SMP-L / SSMP / P-SMP
SMA / PC3.5 / QMA
BMA / BNC 1.0/2.3
N / FME / 7/16
U.FL / W.FL / W.FL2 / X.FL / MM5829
Reverse SMA / TNC
IEC / F (75Ω)
FAKRA / GT13 / GT16
Digital
Switch connector contacting
PCB test point
PCB test point side
Coaxial dipole probe
Accessories

HFS-010, HFS-110, DPS-215 M, DPS-465 M Coaxial di-pole Probes

HFS-010

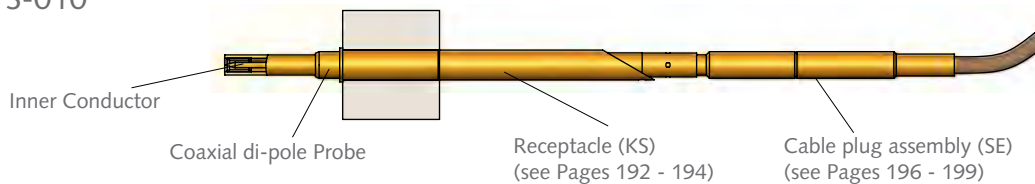

HFS-110 ... A

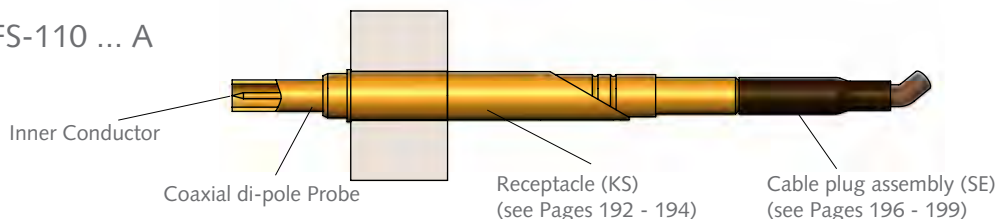

DPS-215 M

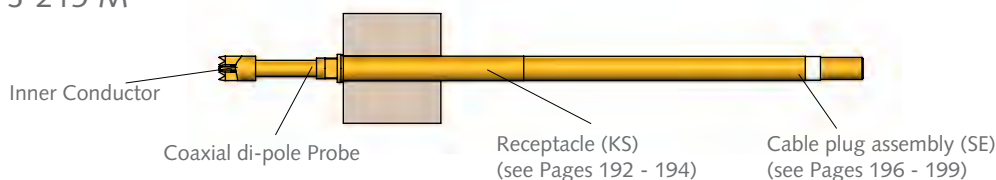

DPS-465 M

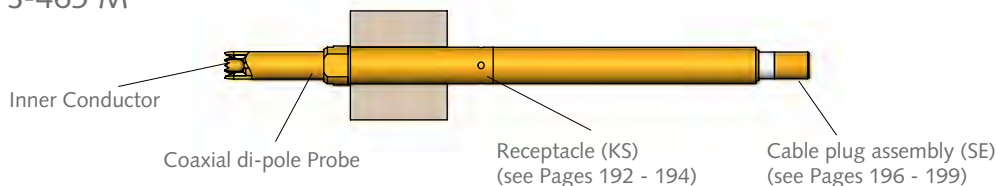

Customizing Example:

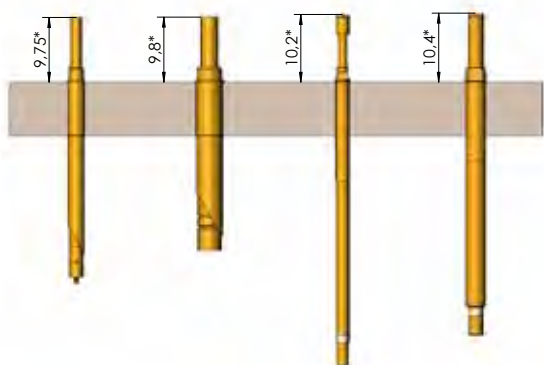

HFS-010 with KS-010 23 HFS-110 ... A with KS-110 23 DPS-215...06M with KS-215 M1,6 DPS-465...02M with KS-465 M2,5

Electrical Data

	HFS-010	HFS-110	DPS-215	DPS-465
Measurement current	2-3 A	2-3 A	0,5 A	10 A (Outer Cond.) 2 A (Inner Cond.)
Measurement voltage	400 V	500 V	300 V	1000 V
R _i typisch	≤ 20 mΩ	≤ 20 mΩ	≤ 20 mΩ	≤ 20 mΩ

Installation Height in Receptacle		KS-010 23	KS-110 23
Variant		*Installation Height HFS in KS	
HFS-010	... A	9.75 mm	---
HFS-110	... A	---	9.8 mm
	... B	---	

Installation Height in Receptacle		KS-215 M1,6 KS-215 M1,6-F KS 215 M1,6-F-R	KS-465 M2,5 KS-465 M2,5-F KS-465 M2,5-F-R
Variant		*Installation Height HFS in KS	
DPS-215 M	... 06 M	10.2 mm	---
DPS-465 M	DPS-465 306 100 A 4002 M	---	10.4 mm
	DPS-465 306 100 A 4006 M	---	
	DPS-465 351 051 A 4002 M	---	
	DPS-465 351 051 A 4006 M	---	

Operating Temperature Range

-40 up to +80° C

Series:

HFS-010 ...

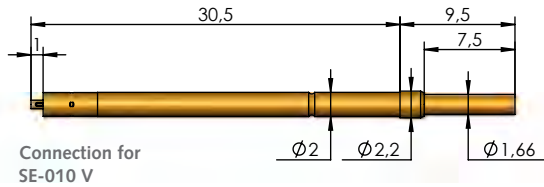

Available
Tip Styles:

Ordering Description:

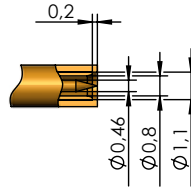

HFS-010 351 050 A **xx** 02 A

Note: Version with Outer Plunger tip-style 02 (flat) and Inner Conductor tip-style 51 (crown).

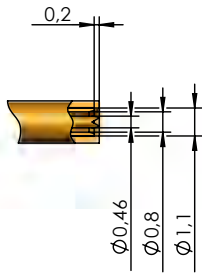

HFS-010 354 050 A **xx** 02 A

Note: Version with Outer Plunger tip-style 02 (flat) and Inner Conductor tip-style 54 (extended crown).

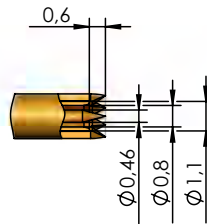

HFS-010 351 050 A **xx** 06 A

Note: Version with Outer Plunger tip-style 06 (serrated) and Inner Conductor tip-style 51 (extended spear-point) for contacting contaminated surfaces.

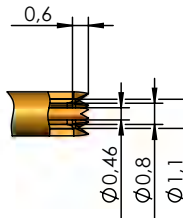

HFS-010 354 050 A **xx** 06 A

Note: Version with Outer Plunger tip-style 06 (serrated) and Inner Conductor tip-style 54 (extended crown) for contacting contaminated surfaces.

Note: (*)

By larger grids than 120 mil (3.00 mm) the Receptacle KS-010 23 can be used (see accessories).

Note:

The Inner Conductor is fixed to the PCB and cannot be exchanged.

The spring-loaded Outer Plunger of the series HFS-010 is available with a shorter installation length on request.

	HFS-010
Spring Force of Inner Conductor (N)	0.8
Spring Force of Outer Conductor (N)	1.2
Character for ordering	20

Mechanical Data

HFS-010

Outer Cond. Inner Cond.

Working Stroke: 5.5 mm 5.5 mm
Maximum Stroke: 7.5 mm 7.5 mm

Assembly Hole in CEM1 and FR4

HFS-010

with Receptacle: Ø 2.48 - 2.49 mm
without Receptacle: Ø 2.00 mm

MMBX / MMCP / MMCPX
 MMB / SMC
 SMP (X/MAX) / SMP-L 55MP / P-5MP
 SMA / PC3.5 QMA
 BMA / BNC 1.0/2.3
 N / FME / 7/16
 U.FL / W.FL / W.FL2 / X.FL / MM5829
 Reverse SMA / TNC
 IEC / F (75 Ω)
 FAKRA / GT13 / GT16
 Digital
 Switch connector contacting
 PCB test point
 PCB test point side
 Coaxial dipole probe
 Accessories

HFS-110 Coaxial di-pole Probe

Grid: ≥ 4.50 mm (*)
 ≥ 180 Mil

HFS-110

Series:

Available
Tip Styles:

Ordering Description:

HFS-110 ... A

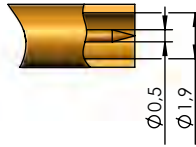
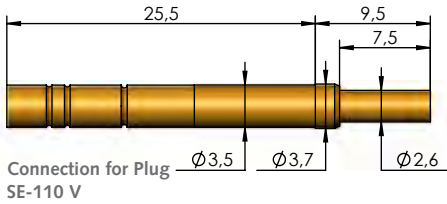

HFS-110 301 050 A **xx** 02 A
HFS-110 301 050 A **xx** 02 B

Note: Version with Outer Plunger tip-style 02 (flat) and Inner Conductor tip-style 01 (spear-point).

HFS-110 ... B

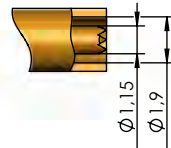
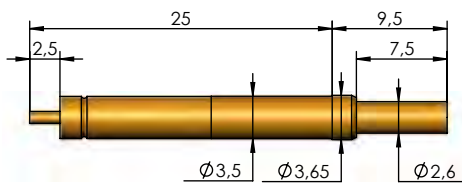

HFS-110 306 115 A **xx** 02 A
HFS-110 306 115 A **xx** 02 B

Note: Version with Outer Plunger tip-style 02 (flat) and Inner Conductor tip-style 06 (serrated).

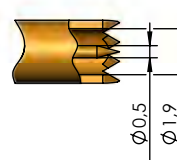

HFS-110 301 050 A **xx** 06 A
HFS-110 301 050 A **xx** 06 B

Note: Version with Outer Plunger tip-style 06 (serrated) and Inner Conductor tip-style 01 (spear-point) for contacting contaminated surfaces.

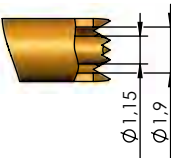

HFS-110 306 115 A **xx** 06 A
HFS-110 306 115 A **xx** 06 B

Note: Version with Outer Plunger tip-style 06 (serrated) and Inner Conductor 06 (serrated) for contacting contaminated surfaces.

Spring force rating

The spring-loaded Outer Conductor are available with different spring forces. The ordering description is derived by adding up the individual values.

Note: (*)

By larger grids than 180 mil (4.5 mm) the Receptacle KS-110 23 can be used (see accessories).

Note:

The Inner Conductor is fixed to the PC-Board and cannot be exchanged.

The series HFS-110 is available with other tip-styles on request.

	HFS-110
Spring Force of Inner Conductor (N)	1.5
Spring Force of Outer Conductor (N)	3.0
Character for ordering	30

Mechanical Data

HFS-110

Assembly Hole in CEM1 and FR4

HFS-110

	Outer Cond.	Inner Cond.
Working Stroke:	4.0 mm	4.0 mm
Maximum Stroke:	5.0 mm	5.0 mm

with Receptacle:	Ø 3.98 - 3.99 mm
without Receptacle:	Ø 3.50 mm

Series:

Available Tip Styles:

Ordering Description:

DPS-215 ... M

DPS-215 304 027 A **xx** 06 M

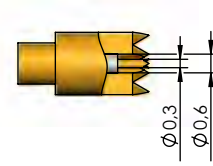
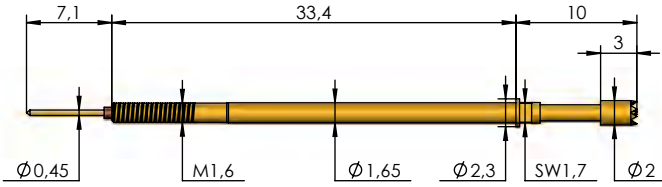

Note: Version with Outer Plunger tip-style 06 (serrated) and Inner Conductor tip-style 04 (extended crown).

Spring force rating

The spring-loaded Outer Conductor are available with different spring forces. The ordering description is derived by adding up the individual values.

Note: (*)

By larger grids than 100 mil (2,54 mm) the receptacle KS-215 M1,6 (I-F/-R) can be used (see accessories).

Note:

The Inner Conductor is fixed to the PC-Board and cannot be exchanged.

	DPS-215
Spring Force of Inner Conductor (N)	0.4
Spring Force of Outer Conductor (N)	1.6
Character for ordering	20

Mechanical Data

DPS-215 M

	Outer Cond.	Inner Cond.
Working Stroke:	4.0 mm	4.0 mm
Maximum Stroke:	5.0 mm	5.0 mm

Assembly Hole in CEM1 and FR4

DPS-215 M

with Receptacle: \varnothing 1.98 - 1.99 mm

MMBX / MMMPX / MMBX / MCB
 SMB / SMC
 SMP (X/MAX) / SMP-L 55MP / P-SMP
 SMA / PC3.5 / QMA
 BMA / BNC / 1,0/2,3
 N / FME / 7/16
 U.FL / W.FL / W.FL2 / X.FL / MM5829
 Reverse SMA / TNC
 IEC / F (75 Ω)
 FAKRA / GT13 / GT16
 Digital
 Switch connector contacting
 PCB test point
 PCB test point side
 Coaxial dipole probe
 Accessories

DPS-465 Coaxial di-pole Probe

Grid: ≥ 4.50 mm (*)
 ≥ 140 Mil

DPS-465 M

Series:

Available
Tip Styles:

Ordering Description:

DPS-465 ... M

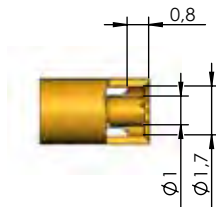
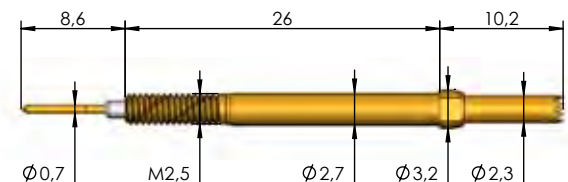

DPS-465 306 100 A **xx** 02 M

Note: Version with Outer Plunger tip-style 02 (flat) and Inner Conductor tip-style 06 (serrated).

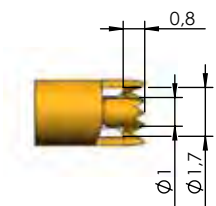

DPS-465 306 100 A **xx** 06 M

Note: Version with Outer Plunger tip-style 02 (serrated) and Inner Conductor tip-style 06 (serrated).

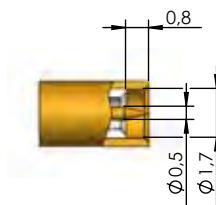

DPS-465 351 050 A **xx** 02 M

Note: Version with Outer Plunger tip-style 02 (flat) and Inner Conductor tip-style 51 (spear-point).

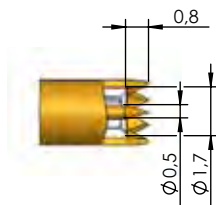

DPS-465 351 050 A **xx** 06 M

Note: Version with Outer Plunger tip-style 06 (serrated) and Inner Conductor 51 (spear-point).

Spring force rating

The spring-loaded Outer Conductor are available with different spring forces. The ordering description is derived by adding up the individual values.

Note: (*)

By larger grids than 140 mil (3,50 mm) the receptacle KS-465 M2,5 (-F/-R) can be used (see accessories).

Note:

The Inner Conductor is fixed to the PC-Board and cannot be exchanged.

	DPS-465
Spring Force of Inner Conductor (N)	1.0
Spring Force of Outer Conductor (N)	3.0
Character for ordering	40

Mechanical Data

DPS-465 M

Assembly Hole in CEM1 and FR4

DPS-465 M

	Outer Cond.	Inner Cond.
Working Stroke:	4.0 mm	4.0 mm
Maximum Stroke:	5.0 mm	5.0 mm

with Receptacle: Ø 2.98 - 2.99 mm

Accessories

Receptacles (KS)

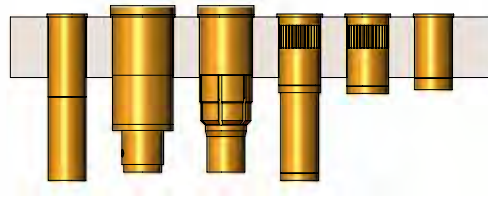

Spacer of Receptacles (DS)



Cable Connector Assembly (SE)



Adapter



Tools



Inner Conductor / Signal Conductor

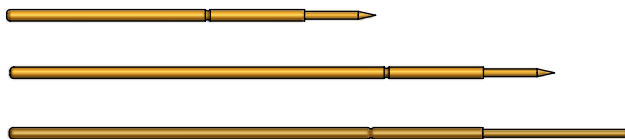

All specifications are subject to change without prior notification

Contents

Accessories

Receptacles (KS)	192 - 194
Spacer of Receptacles (DS)	195
Cable plug assembly (SE)	196 - 199
Tools	200 - 201
Inner Conductor / Signal Conductor	202 - 204

MMBX /
MMCK / MMMPX
MBX / MCK

SMB / SMC

SMP (X/MAX)
SMP-L 55MP /
P-5MP

SMA / PC3.5
QMA

BMA / BNC
1.0/2.3

N / FME /
7/16

U.FL / W.FL /
W.FL2 / X.FL /
MM5829

Reverse
SMA / TNC

IEC /
F (75 Ω)

FAKRA /
GT13 / GT16

Digital

Switch
connector
contacting

PCB
test point

PCB test
point side

Coaxial
dipole probe

Accessories

Receptacles

KS-810 Receptacle with securing crimps
KS-810 R Receptacle with securing crimps and knurl
KS-810 F Flange Receptacle with securing crimps

for all HFS ... of series HFS-810/840/860/865 without thread.

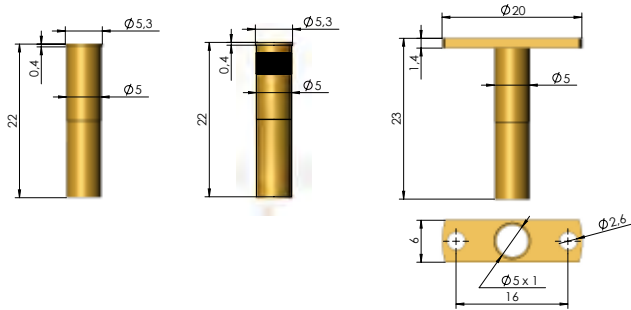

KS-810

KS-810 R

KS-810 F

KS-810 M5-R Receptacle with inner thread and knurl
KS-810 M5-F Flange Receptacle with inner thread

for all HFS ... M (4M) of series HFS-810/840/860 with thread.

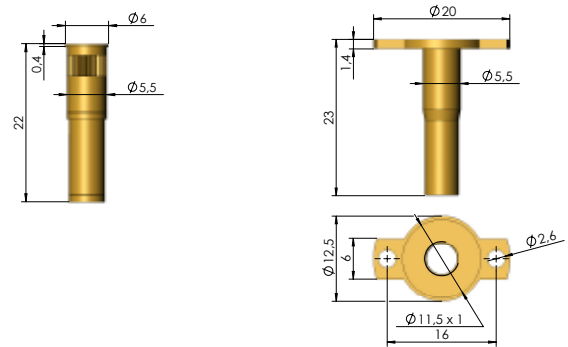

KS-810 M5-R

KS-810 M5-F

KS-410 Receptacle with securing crimps
KS-410 F Flange Receptacle with securing crimps

for all HFS ... of series HFS-410/440 without thread.

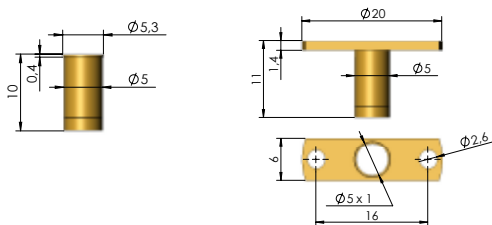

KS-410

KS-410 F

KS-410 KM5-R Receptacle with inner thread and knurl
KS-410 KM5-F Flange Receptacle with inner thread

for all HFS ... M (4M) of series HFS-410/440 with thread.

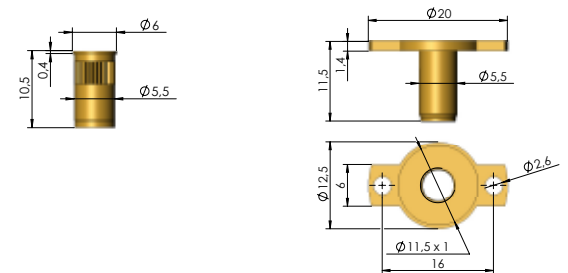

KS-410 KM5-R

KS-410 KM5-F

Assembly Bore in CEM1 and FR4:

with Receptacle KS-810/KS-410: \varnothing 4.98 - 4.99 mm
 with Receptacle KS-810 R: \varnothing 5.00 - 5.02 mm
 with Receptacle KS-810 M5-R/KS-410 KM5-R: \varnothing 5.50 - 5.52 mm

KS-858 Receptacle with securing crimps

for all HFS of series **HFS-858** without thread

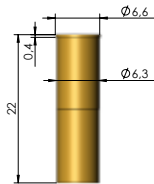

KS-858

KS-010 23 Receptacle with securing crimps
KS-110 23 Receptacle with securing crimps

for all HFS of series **HFS-010** respectively **HFS-110**.

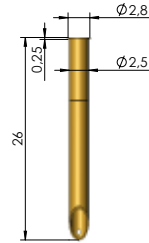

KS-010 23

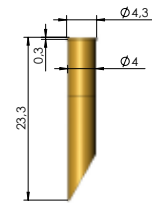

KS-110 23

KS-215 M1,6 Receptacle with securing crimps
KS-215 M1,6-F Receptacle with securing crimps (quick exchange system)
KS-215 M1,6-F-R Receptacle with securing crimps and knurl (quick exchange system)

for all DPS of series **DPS-215 M**.

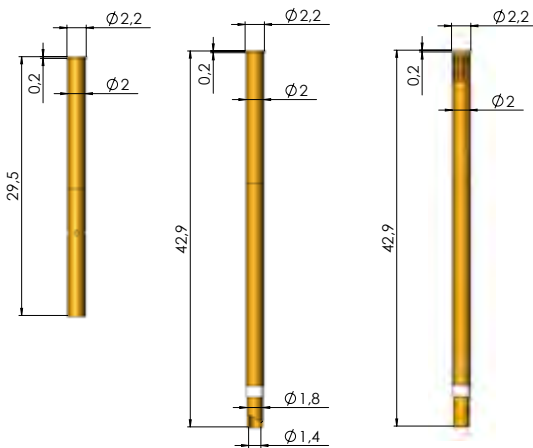

KS-215 M1,6

KS-215 M1,6-F

KS-215 M1,6-F-R

KS-465 M2,5 Receptacle with securing crimps
KS-465 M2,5-F Receptacle with securing crimps (quick exchange system)
KS-465 M2,5-F-R Receptacle with securing crimps and knurl (quick exchange system)

for all DPS of series **DPS-465 M**.

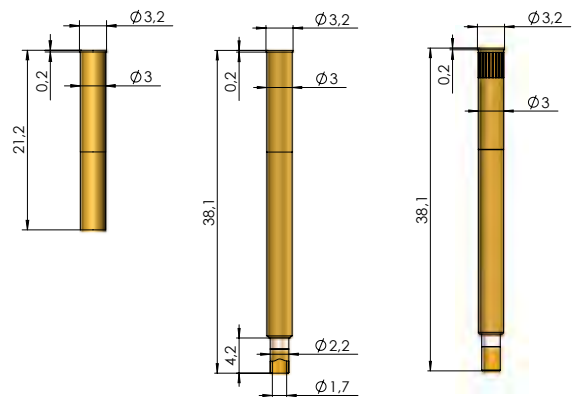

KS-465 M2,5

KS-465 M2,5-F

KS-465 M2,5-F-R

Assembly Bore in CEM1 and FR4:

with Receptacle KS-858: \varnothing 6.28 - 6.29 mm
with Receptacle KS-010 23: \varnothing 2.48 - 2.49 mm
with Receptacle KS-110 23: \varnothing 3.98 - 3.99 mm
with Receptacle KS-215 M1,6 (-F/-F-R): \varnothing 1.98 - 1.99 mm
with Receptacle KS-465 M2,5 (-F/-F-R): \varnothing 2.98 - 2.99 mm

Receptacles

For all HFS of series **HFS-810/840/860/865** without thread.

Due to its special design, the flexible Receptacle can absorb side-loads and positioning inaccuracies better, which can occur due to misalignment of the PC-Board/RF Plug Connector.

- HAS-810 220** flexible Receptacle
($\pm 3,5^\circ$ Angular alignment, Grid $\geq 9,0$ mm)
- HAS-810 220 F** flexible Flange Receptacle
($\pm 3,5^\circ$ Angular alignment)

Operating Temperature Range -40° up to $+80^\circ$ C

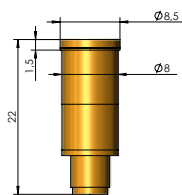

HAS-810 220

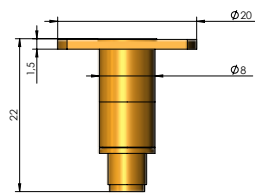

HAS-810 220 F

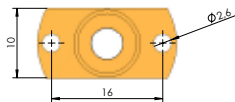

For all HFS of series **HFS-810/840/860/865** without thread.

Due to its special design, the flexible Receptacle can absorb side-loads and positioning inaccuracies better, which can occur due to misalignment of the PC-Board/RF Plug Connector.

- HAS-810 220 740** flexible Receptacle
($\pm 2,5^\circ$ Angular alignment, Grid $\geq 8,0$ mm)
- HAS-810 220 740 F** flexible Flange Receptacle
($\pm 2,5^\circ$ Angular alignment)

Operating Temperature Range -40° up to $+80^\circ$ C

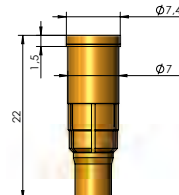

HAS-810 220 740

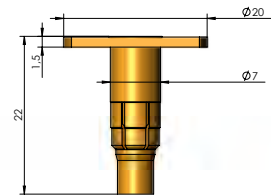

HAS-810 220 740 F

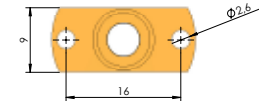

HAS-819 flexible Mounting for all RF Probes of series **HFS-819** with the **spring force index 127**.

HAS-819 160 flexible Mounting with increased spring-force for all RF Probes of series **HFS-819** with the **spring force index 207**.

Operating Temperature Range max. $+40^\circ$ C

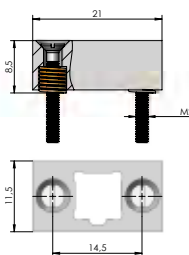

**HAS-819/
HAS-819 160**
(Consisting of Contact Mounting, Threaded Pins, Springs and Screws)

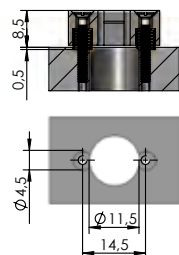

Customizing recommendation for Mounting Plate

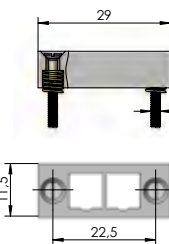

HAS-819 D8-160
(Consisting of Contact Mounting, Threaded Pins, Springs and Screws)

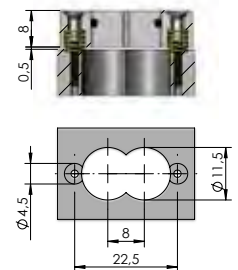

Customizing recommendation for Mounting Plate

Assembly Bore in CEM1 and FR4:

- with flexible Receptacle HAS-810 220: $\varnothing 7,98 - 7,99$ mm
- with flexible Receptacle HAS-810 220 740: $\varnothing 6,98 - 6,99$ mm
- with flexible Mounting HAS-819/HAS-819 160: see customizing recommendation
- with flexible Mounting HAS-819 D8-160: see customizing recommendation

Spacer of Receptacles

DS-810 0x 50 N

Spacers for Barrel of RF Probe

To increase the installation height by 1, 2 or 4 mm the spacers **DS-810 0x 50 N** can be placed over the barrel respectively under the collar of the RF probe before it is pressed in.
For all HFS of series **HFS-410/440/810/840/860/865** without thread.

DS-810 0x N

Spacers for the Receptacles KS-810 + KS-410

To increase the installation height by 1, 2 or 4 mm the spacers **DS-810 0x N** can be placed under the collar of the Receptacle before it is pressed into the assembly hole.

For the **Receptacles KS-810 and KS-410**.

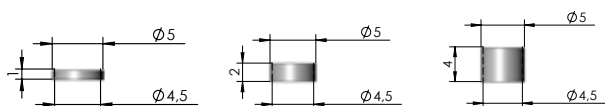

DS-810 01 50 N

DS-810 02 50 N

DS-810 04 50 N

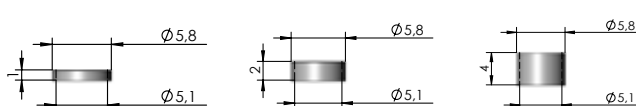

DS-810 01 N

DS-810 02 N

DS-810 04 N

Coaxial cables and cable assemblies

Introduction

Apart from the RF Probe itself, the cable-plug assemblies provide the most important link between Test System and UUT. Good signal transmission is an important factor in assuring high quality measurements – hence choosing the right cable type is crucial for guaranteeing low loss transmission along with other properties like good matching and phase stability.



RF cable plug assembly

The higher the frequency the higher the requirements are in regard to signal transmission properties of the cable. INGUN offers various pre-wired cable-types for the RF product series.

Loss calculation of the cable (without the plug connector)

The loss can be estimated by using the following equation:

$$\alpha \text{ [dB]} = (a \cdot \sqrt{f} + b \cdot f) \cdot l \quad f \text{ in [GHz], } l \text{ in [m]}$$

Example: Loss calculation for the cable SE-RG316-50MCXMG070 (length: 70 cm at $f = 1.5$ GHz):
 $\alpha = (0.7727 \cdot \sqrt{1.5} + 0.0972 \cdot 1.5) \cdot 0.7 \text{ dB} \approx 0.8 \text{ dB}$.
 The correct loss coefficients a and b of the cable (here: RG316 /U) can be found in the table below. Using an assembly rather than only the cable, you need to add the loss properties of the MCX connector and the second coaxial interface (if available). For normal usage however these values are mostly neglectable.

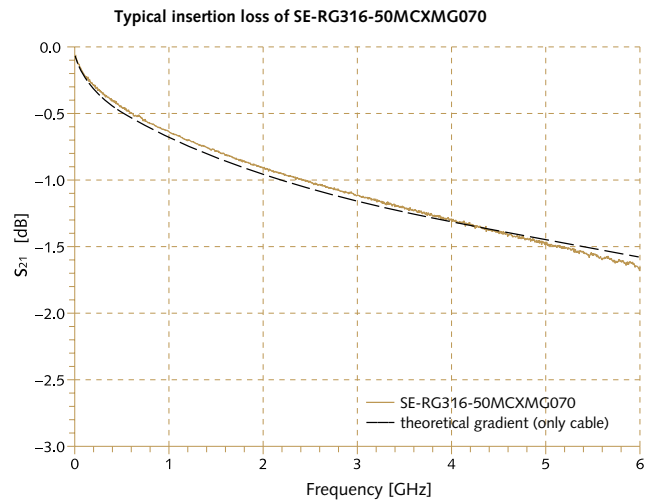

Cable type	K_01152-07	RG178 B/U	ENVIROFLEX_178	RG316 /U	ENVIROFLEX_316_D	MULTIFLEX_86	RTK-FLEX405-SPC-FEP	RG59 B/U	RG179 B/U
Impedance [Ω]	50	50	50	50	50	50	50	75	75
fmax [GHz]	1	1	3	3	6	40	60	1	1
Shielding effectiveness [dB]	> 40 bis 1 GHz	> 40 bis 1 GHz	> 40 bis 3 GHz	> 38 bis 1 GHz	> 80 bis 6 GHz	> 90 bis 18 GHz	> 90 bis 1 GHz	> 40 bis 1 GHz	> 41 bis 1 GHz
Material of the inner conductor	Cu, Ag plated	St., Cu + Ag plated	St., Cu + Ag plated	St., Cu + Ag plated	St., Cu + Ag plated	Cu, Ag plated	Cu, Ag plated	Cu	St., Cu + Ag plated
Dielectric	PFA (εr = 2.1)	PTFE (εr = 2.1)	SPEX (εr = 2.0)	PTFE (εr = 2.1)	SPEX (εr = 2.0)	PTFE (εr = 2.0)	FEP (εr = 2.0)	PE (εr = 2.3)	PTFE (εr = 2.1)
Loss coefficient a	2.21	1.408	1.4067	.7727	.7182	.71702	.6912	.3173	.73
Loss coefficient b	.259	.2296	.2229	.0972	.1682	.02892	.0412	.0499	.1014
min. bending radius static [mm]	6	10	5	15	5	6	7.6	32	15
min. bending radius dynamic [mm]	20	20 (for max. 50 identical movements)	30	37.5	30	20	15	65 (for max. 50 identical movements)	38

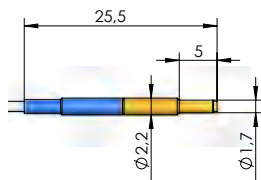

SE-010

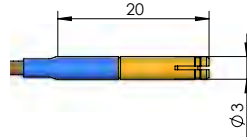

SE-110

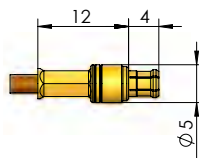

MCX-plug (straight)*

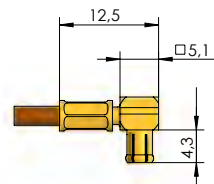

MCX-m (angular 90°)*

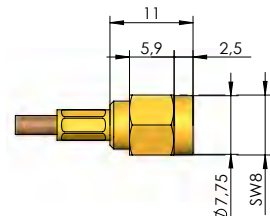

SMA-m (straight)*

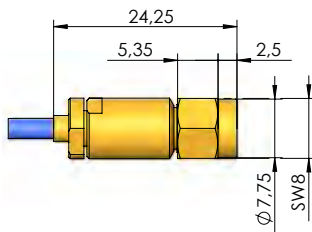

PC3.5-m (straight)

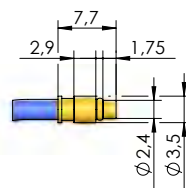

MMPX™-m (straight)

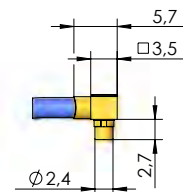

MMPX™-m (angular 90°)

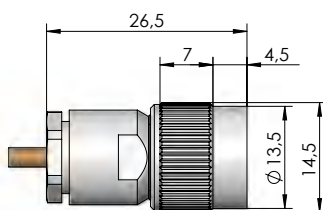

Note: (*)
 Plug with bend protection. Finish with shrink hose (20 mm).

Adapter

MCX-m adapter for SMA-f



Ordering number
 HFS-ADA-MCX-M-SMA-F

MCX-m adapter for PC3.5-f



Ordering number
 HFS-ADA-MCX-M-PC35-F

PC3.5-m adapter for MCX-f



Ordering number
 HFS-ADA-PC35-M-MCX-F

Cable plug assembly up to max. 0.2 GHz for HFS-010				
Ordering No.	Configuration Interface 1	Cable length and type	Interface 2	f _{max}
SE-K11527-50010MG075	SE-010	75 cm, K_01152-07	open	0.2 GHz

Cable plug assembly up to max. 0.7 GHz for HFS-110				
Ordering No.	Configuration Interface 1	Cable length and type	Interface 2	f _{max}
SE-RG178-50110MG075	SE-110	75 cm, RG178 B/U	open	0.7 GHz

Cable plug assembly up to max. 6 GHz for HFS-4(8)10, HFS-4(8)40 and HFS-860				
Ordering No.	Configuration Interface 1	Cable length and type	Interface 2	f _{max}
SE-RG316-50MCXMG070	MCX-m (straight)	70 cm, RG316 /U	open	3 GHz
SE-RG316-50MCXMW070	MCX-m (angular 90°)	70 cm, RG316 /U	open	3 GHz
SE-RG316-50MCXMG150	MCX-m (straight)	150 cm, RG316 /U	open	3 GHz
SE-RG316-50MCXMW150	MCX-m (angular 90°)	150 cm, RG316 /U	open	3 GHz
SE-RG316-50MCXMG058SMAMG	MCX-m (straight)	58 cm, RG316 /U	SMA-m (straight)	3 GHz
SE-EF316D-50MCXMG080	MCX-m (straight)	80 cm, ENVIROFLEX_316_D	open	6 GHz
SE-EF316D-50MCXMG080SMAMG	MCX-m (straight)	80 cm, ENVIROFLEX_316_D	SMA-m (straight)	6 GHz
SE-EF316D-50MCXMW080	MCX-m (angular 90°)	80 cm, ENVIROFLEX_316_D	open	6 GHz
SE-EF316D-50MCXMW080SMAMG	MCX-m (angular 90°)	80 cm, ENVIROFLEX_316_D	SMA-m (straight)	6 GHz

Cable plug assembly up to max. 18 GHz for HFS-822, HFS-823 and HFS-856				
Ordering No.	Configuration Interface 1	Cable length and type	Interface 2	f _{max}
SE-RG316-50SMAMG080SMAMG	SMA-m (straight)	80 cm, RG316 /U	SMA-m (straight)	3 GHz
SE-EF316D-50SMAMG080SMAMG	SMA-m (straight)	80 cm, ENVIROFLEX_316_D	SMA-m (straight)	6 GHz
SE-MF86-50SMAMG080SMAMG	SMA-m (straight)	80 cm, MULTIFLEX_86	SMA-m (straight)	18 GHz

Cable plug assembly up to max. 33 GHz for HFS-865				
Ordering No.	Configuration Interface 1	Cable length and type	Interface 2	f _{max}
SE-MF86-50MMPXMG080PC35MG	MMPXTM-m (straight)	80 cm, MULTIFLEX_86	PC3.5-m (straight)	33 GHz
SE-MF86-50MMPXMW080PC35MG	MMPXTM-m (angular 90°)	80 cm, MULTIFLEX_86	PC3.5-m (straight)	33 GHz

Cable plug assembly for special applications					
Ordering No.	Configuration Interface 1	Cable length and type	Interface 2	f _{max}	Application
SE-RG316-50MCXMG070S	MCX-m (straight)	70 cm, RG316/U	open	3 GHz	MCX-plug with additional isolation
SE-RG316-50MCXMG150S	MCX-m (straight)	150 cm, RG316/U	open	3 GHz	MCX-plug with additional isolation

SE-EF178-50MCXMG080	MCX-m (straight)	80 cm, ENVIROFLEX_178	open	3 GHz	highly flexible cable for HFS-4(8)10 and HFS-4(8)40
SE-EF178-50MCXMG080SMAMG	MCX-m (straight)	80 cm, ENVIROFLEX_178	SMA-m (straight)	3 GHz	highly flexible cable for HFS-4(8)10 and HFS-4(8)40
SE-EF178-50MCXMW080	MCX-m (angular 90°)	80 cm, ENVIROFLEX_178	open	3 GHz	highly flexible cable for HFS-4(8)10 and HFS-4(8)40
SE-EF178-50MCXMW080SMAMG	MCX-m (angular 90°)	80 cm, ENVIROFLEX_178	SMA-m (straight)	3 GHz	highly flexible cable for HFS-4(8)10 and HFS-4(8)40

SE-FLX405-50SMPMFG050SMAMG	SMPM-f (straight)	50 cm, RTK-FLEX405-SPC-FEP	SMA-m (straight)	18 GHz	for HFS-837 and HFS-852
----------------------------	-------------------	----------------------------	------------------	--------	-------------------------

SE-RG59-75TNCMG070	TNC-m (straight)	70 cm, RG59/U	open	1 GHz	for HFS-409
SE-RG179-75MCXMG070	MCX-m (straight)	70 cm, RG179 B/U	open	1 GHz	for HFS-858

Nomenclature	
f	female = Signal Conductor Jack
m	male = Signal Conductor Plug
f _{max}	max. frequency

Note:
Other configurations and special lengths on request.

More information and data sheets regarding the Cable Assemblies can be downloaded from our homepage www.ingun.com or are available on request.

MMBX / MMCK / MMMPX / MBX / MCK
 SMB / SMC
 SMP (X/ MAX) / SMP-L / SSMP / P-SMP
 SMA / PC3.5 / QMA
 BMA / BNC 1.0/2.3
 N / FME / 7/16
 U.FL / W.FL / W.FL2 / X.FL / MM5829
 Reverse SMA / TNC
 IEC / F (75 Ω)
 FAKRA / GT13 / GT16
 Digital
 Switch connector contacting
 PCB test point
 PCB test point side
 Coaxial dipole probe
 Accessories

SE-819 V2 for HFS-819 ... with Plug Connection

The Connector SE-819 V2 is not pre-wired and is supplied as a solder version. To prevent interchanging of the pole designation the Connector has a position detection marking.

SE-819 V2 for HFS-819

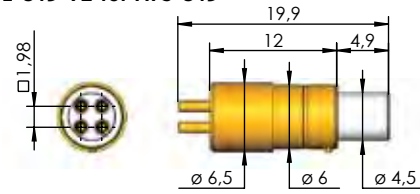

SE-819 V5-Z for HFS-819
SE-821 for HFS-821

The screw-on plug connector SE-819 V5-Z for HFS-819 and the plug connector SE-821... for HFS-821 with a lock nut for securing purposes is not pre-wired and is supplied as a solder version. To prevent damage of the solder connection due to incorrect tensile loading of the cable, the screw-on plug connectors are equipped with a strain relief on the connectors. To prevent interchanging of the pole designation the connector has a position detection marking.

SE-819 V5-Z for HFS-819

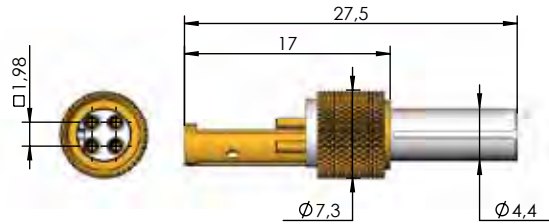

SE-821 MX38 for HFS-821

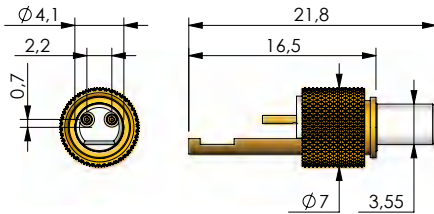

SE-821 MX48 for HFS-821

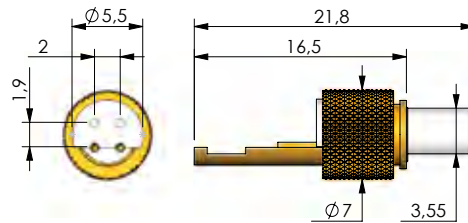

SE-821 MX49 for HFS-821

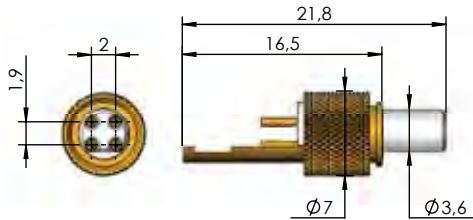

SE-821 MX62 for HFS-821

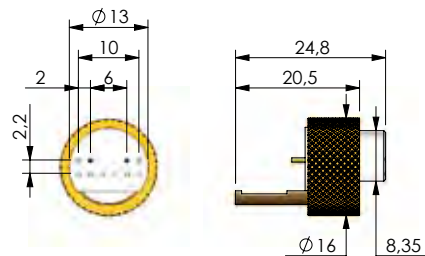

SE-821 MX68 for HFS-821

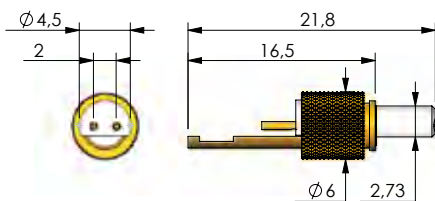

SE-821 USB-Mini for HFS-821

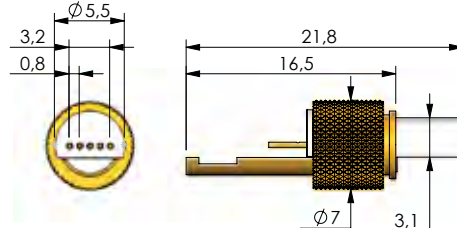

HFS test set / PCB simulator

Special RF test set, which simulates the test point on the PCB. The set consists of two SMA adaptations, two grounding plates and a connecting sleeve for the singular „back to back“ measurement.

Ordering number:
SET-HFS-TEST-0001



Attenuators for RF test probes

Inline attenuators for modification or artificial improvement of return loss. 50 Ω attenuator with 3 dB and 2 Watt load capacity, as well as optional MCX or SMA connection interface. More attenuator values are available upon request.

Ordering number MCX-Connection: **HFS-ADA-0001** Ordering number MCX-Connection: **HFS-ADA-0002**



SW-GKS (Insertion Tool for KS)

Universal Insertion Tool for Receptacles. The SW-GKS consists of a handle SW-H and a screwed in, flat plastic Insert E-SW GKS with a diameter of 5.8 mm.



SW-GKS

SW-HFS-810-S (Insertion Tool for HFS)

Insertion Tool for RF Probes series HFS-410/440/810/840/ 860 with an Outer Plunger diameter < 4.0 mm. The SW-HFS-810-S consists of a handle SW-H and a screwed in Insert E-SW-HFS-810-S

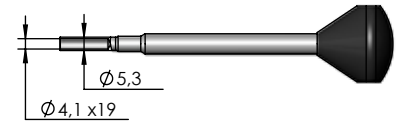

SW-HFS-810-S

SW-ZW-HFS-810 (Insertion and Extraction Tool for RF Probes)

Insertion and Extraction Tool for RF Probes series HFS-410/440/810/840/ 860 with an Outer Plunger diameter between 4.1 and 11.4 mm. The SW-HFS-810 consists of a handle SW-H and a screwed in Insert E-SW-HFS-810.

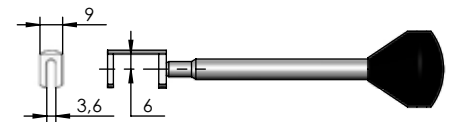

SW-ZW-HFS-810

SW-GKS-187 B (Insertion Tool for the Inner Conductor Probe GKS-051)

Insertion Tool for the RF Inner Conductor Probe series GKS-051 with tip-diameter ≤ 0.51 mm. The SW-GKS-187 B consists of a handle SW-H and a screwed in Insert E-SW-GKS-187-B.



SW-GKS-187-B

SW-ZW-GKS-051 (Insertion and Extraction Tool for the Inner Conductor Probe GKS-051)

Insertion and Extraction Tool for the RF Inner Conductor Probe series GKS-051 with Inner Conductor tip-diameter > 0.51 mm and the smallest inner diameter of the Outer Plunger of > 4.0 mm. The SW-ZW-GKS-051 consists of a handle SW-G and a screwed in Insert E-SW-ZW-GKS-051.

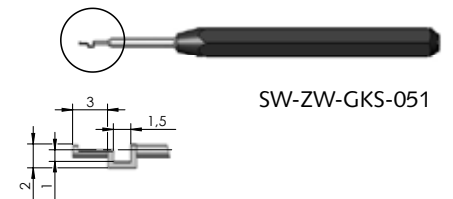

SW-ZW-GKS-051

DW-GS-SW8-45 (Torque Wrench for SMA HF-Connector)

8 mm (5/16") Width across flats - 45 Ncm Torque

DW-GS-SW8-100 (Torque Wrench for PC3.5 HF- Connector)

8 mm (5/16") Width across flats - 100 Ncm Torque

The Precision Torque Wrench is used to tighten the coupling nut of HF Connectors.

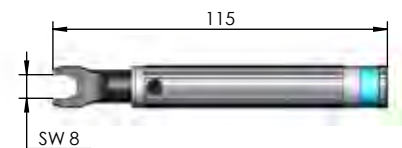

SMA, PC3.5 Torque Wrench

GS-810 SW 3.5 (Wrench for HFS Outer Plungers)

GS-810 SW 4.0 (Wrench for HFS Body)

Tools for de-assembly and assembly of RF Probes series HFS-810/840/410/440/860

GS-822 SW 8.0 (Wrench for RF Probe with SMA-/PC3.5 Connection)

Tools for de-assembly and assembly of RF Probes with SMA respectively PC3.5 Connection (SW8).



GS-810 SW 3.5 (4.0, 8.0)

BIT-HFS-810 M (Screwing Tool for HFS- ... M/4M)

Bit Tool for screwing in and screwing out the RF Probes HFS-... M (4M) with a maximum tip diameter of 8.0 mm.

The Screwing Tool is equipped with a 1/4" Bit Insert System.

In the case of limited space the Bit Tools can also be used without the Torque Spanner.

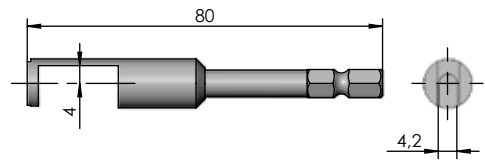

BIT-HFS-810 M

BIT-GKS-112 M (Screwing Tool for DPS-215 and HFS-409)

Screwing tool for screwing and unscrewing the DPS-215 series (3-5 Ncm), as well as for screwing and unscrewing the inner conductors in the HFS-409 series (3-5 Ncm).

The Screwing Tool is equipped with a 1/4" Bit Insert System.

In the case of limited space the Bit Tools can also be used without the Torque Spanner.

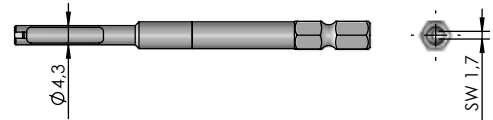

BIT-GKS-112 M

BIT-SKS-465 M (Screwing Tool for DPS-465)

Screwing tool for screwing and unscrewing the DPS-465 (3-5 Ncm).

The Screwing Tool is equipped with a 1/4" Bit Insert System.

In the case of limited space the Bit Tools can also be used without the Torque Spanner.

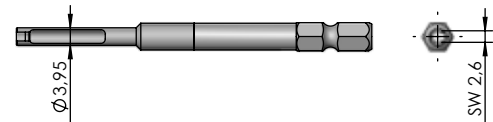

BIT-SKS-465 M

DW-20-120 (Torque Wrench for BIT-... M)

The adjustable torque wrench (20-120 Ncm) is used in combination with the bit tools.



DW-20-120

DW-20 (Torque Wrench for BIT-... M)

The pre-set torque wrench (20 Ncm) is used in combination with the bit tools.



DW-20

DW-5-S (Torque Wrench for BIT-... M)

The pre-set torque wrench (5 Ncm) is used in combination with the bit tools.



DW-5-S

INGUN RF Probes according to Part No. and Inner Conductor

Part No. RF Probe	Part No. Inner Conductor	Page
DPS-215 304 027 A 2006 M	not interchangeable	189
DPS-465 3xx 050 A 400x M	not interchangeable	190
HFS-010 35x 050 A 200x A	not interchangeable	187
HFS-110 30x 050 A 300x x	not interchangeable	188
HFS-409 305 100 A 8343 MF	HSS-118 306 350 A 3005 M	108
HFS-409 306 350 8342 M	HSS-118 306 350 A 3002 M	107
HFS-409 306 350 8343 M	HSS-118 306 350 A 3002 M	107
HFS-410 358 180 A xx42 Q (M)	GKS-051 358 180 A 1000 K1	81
HFS-4x0 201 051 A xx02 (M)	GKS-051 201 051 A 1000 K1	156/157
HFS-4x0 201 051 A xx02 S (4M)	GKS-051 201 051 A 1000 K1	158/159
HFS-4x0 201 051 A xx06 (M)	GKS-051 201 051 A 1000 K1	156/157
HFS-4x0 201 051 A xx06 P (4M)	GKS-051 201 051 A 1000 K1	161/162
HFS-4x0 201 051 A xx06 S (4M)	GKS-051 201 051 A 1000 K1	158/159
HFS-4x0 201 051 A xx14 VZ (4M)	GKS-051 201 051 A 1000 K1-N15	183
HFS-4x0 201 051 A xx29 V2 (4M)	GKS-051 201 051 A 0000 K1	170/172
HFS-4x0 201 051 A xx29 V2-5x (4M)	GKS-051 201 051 A 0000 K1	170/172
HFS-4x0 201 051 A xx29 V2-VZ (4M)	GKS-051 201 051 A 0000 K1	184
HFS-4x0 204 051 A xx02 V1-AS3 (4M)	GKS-051 204 051 A 0000 K1	164/165
HFS-4x0 358 051 A xx02 V2-00S (4M)	GKS-051 358 080 A 0000 K1-L	164/165
HFS-4x0 204 051 A xx02 V2-360 (4M)	GKS-051 204 051 A 0000 K1	177/178
HFS-4x0 303 090 A xx40 GT13 (4M)	GKS-051 303 090 A 1000 K1	115/116
HFS-4x0 303 090 A xx43 Y6 (M)	GKS-051 303 090 A 1000 K1	90/91
HFS-4x0 303 090 xx42 GT16 (M)	GKS-051 303 090 A 1000 K1	117/118
HFS-4x0 303 150 A xx02 D (M)	GKS-051 303 150 A 1000 K1	73/74
HFS-4x0 303 150 A xx42 E (M)	GKS-051 303 150 A 1000 K1	52/53
HFS-4x0 303 150 A xx42 F (M)	GKS-051 303 150 A 1000 K1	111/112
HFS-4x0 303 150 A xx42 FS1 (M)	GKS-051 303 150 A 1000 K1	111/112
HFS-4x0 303 150 A xx42 RF3 (M)	GKS-051 303 150 A 1000 K1	111/112
HFS-4x0 303 150 A xx42 W (M)	GKS-051 303 150 A 1000 K1	83/84
HFS-4x0 303 150 A xx43 E3 (M)	GKS-051 303 150 A 1000 K1	63/64
HFS-4x0 303 150 A xx43 F-Y14 (M)	GKS-051 303 150 A 1000 K1	43/44
HFS-4x0 303 150 A xx43 QN (M)	GKS-051 303 150 A 1000 K1	102/103
HFS-4x0 303 150 A xx43 Y (M)	GKS-051 303 150 A 1000 K1	43/44
HFS-4x0 303 150 A xx43 Y2 (M)	GKS-051 303 150 A 1000 K1	43/44
HFS-4x0 303 150 A xx43 Y3 (M)	GKS-051 303 150 A 1000 K1	43/44
HFS-4x0 303 150 A xx43 Y5 (M)	GKS-051 303 150 A 1000 K1	47/48
HFS-4x0 307 100 A xx02 V2-36S (4M)	GKS-051 307 100 A 0000 K1	177/178
HFS-4x0 308 080 A xx42 GT16-F (4M)	GKS-051 308 080 A 1000 K1	119/120
HFS-4x0 308 080 A xx42 X4 (M)	GKS-051 308 080 A 1000 K1	38/39
HFS-4x0 308 080 A xx42 ZE (M)	GKS-051 308 080 A 1000 K1	45/46
HFS-4x0 308 080 A xx42 ZE3 (M)	GKS-051 308 080 A 1000 K1	113/114
HFS-4x0 308 080 A xx43 T (M)	GKS-051 308 080 A 1000 K1	77/78
HFS-4x0 308 080 A xx43 X (M)	GKS-051 308 080 A 1000 K1	38/39
HFS-4x0 308 110 A xx42 BX (M)	GKS-051 308 110 A 1000 K1	28/29
HFS-4x0 308 180 A xx42 E (M)	GKS-051 308 180 A 1000 K1	65/66
HFS-4x0 308 180 A xx42 MBX (M)	GKS-051 308 180 A 1000 K1	35/36
HFS-4x0 308 180 A xx43 E (M)	GKS-051 308 180 A 1000 K1	65/66
HFS-4x0 204 051 A xx02 V2 (4M)	GKS-051 204 051 A 0000 K1	171/174
HFS-4x0 358 080 A xx02 V2-09S (4M)	GKS-051 358 080 A 0000 K1-L	171/174
HFS-4x0 358 080 A xx42 Z (M)	GKS-051 358 080 A 1000 K1	31/32
HFS-4x0 358 180 A xx42 QS (M)	GKS-051 358 080 A 1000 K1	75/76
HFS-440 007 051 A xx07 Px-AS (4M)	not interchangeable	169
HFS-810 358 180 A xx42 Q (M)	GKS-051 358 180 A xx00	81
HFS-840 007 051 A xx07 Px-AS (4M)	not interchangeable	169
HFS-8x0 201 051 A xx02 (M)	GKS-051 201 051 A xx00	156/157
HFS-8x0 201 051 A xx02 S (4M)	GKS-051 201 051 A xx00	158/159

Nomenclature	
f	female = Signal Conductor Jack
m	male = Signal Conductor Plug
S	Signal
G	Ground
Example: GSG 2 Ground Pins, 1 Signal Pin	
x	Part No. available as 410 (440) or 810 (840) (2 respectively 4 GHz)
xx	Spring Force variants
HFS-4(8)10	Part No. available as HFS-410 and HFS-810
HFS-4(8)40	Part No. available as HFS-440 and HFS-840
HFS-...(M)	Part No. also available as screw-in version
HFS-...(4M)	Part No. also available as adjustable screw-in version

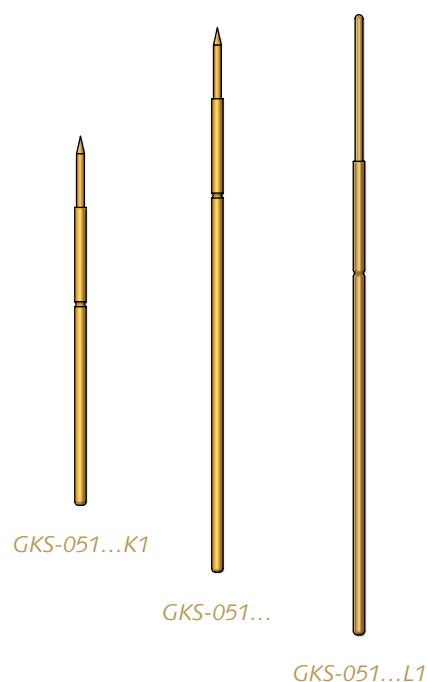

Part No. RF Probe	Part No. Inner Conductor	Page
HFS-8x0 201 051 A xx06 (M)	GKS-051 201 051 A xx00	156/157
HFS-8x0 201 051 A xx06 P (4M)	GKS-051 201 051 A xx00	161/162
HFS-8x0 201 051 A xx06 S (4M)	GKS-051 201 051 A xx00	158/159
HFS-8x0 201 051 A xx14 VZ (4M)	GKS-051 201 051 A 1300 N15	183
HFS-8x0 201 051 A xx29 V2 (4M)	UKS-051 201 051 A	170/172
HFS-8x0 201 051 A xx29 V2-Sx (4M)	UKS-051 201 051 A	170/172
HFS-8x0 201 051 A xx29 V2-VZ (4M)	UKS-051 201 051 A	184
HFS-8x0 204 051 A xx02 V1-AS3 (4M)	UKS-051 201 051 A	164/165
HFS-8x0 358 051 A xx02 V2-00S (4M)	GKS-051 358 080 A 0000 L	164/165
HFS-8x0 204 051 A xx02 V2-360 (4M)	UKS-051 204 051 A	177/178
HFS-8x0 303 090 A xx40 GT13 (4M)	GKS-051 303 090 A xx00	115/116
HFS-8x0 303 090 A xx43 Y6 (M)	GKS-051 303 090 A xx00	90/91
HFS-8x0 303 090 xx42 GT16 (M)	GKS-051 303 090 A xx00	117/118
HFS-8x0 303 150 A xx02 D (M)	GKS-051 303 150 A xx00	73/74
HFS-8x0 303 150 A xx42 E (M)	GKS-051 303 150 A xx00	52/53
HFS-8x0 303 150 A xx42 F (M)	GKS-051 303 150 A xx00	111/112
HFS-8x0 303 150 A xx42 FS1 (M)	GKS-051 303 150 A xx00	111/112
HFS-8x0 303 150 A xx42 RF3 (M)	GKS-051 303 150 A xx00	111/112
HFS-8x0 303 150 A xx42 W (M)	GKS-051 303 150 A xx00	83/84
HFS-8x0 303 150 A xx43 E3 (M)	GKS-051 303 150 A xx00	63/64
HFS-8x0 303 150 A xx43 F-Y14 (M)	GKS-051 303 150 A xx00	43/44
HFS-8x0 303 150 A xx43 QN (M)	GKS-051 303 150 A xx00	102/103
HFS-8x0 303 150 A xx43 Y (M)	GKS-051 303 150 A xx00	43/44
HFS-8x0 303 150 A xx43 Y2 (M)	GKS-051 303 150 A xx00	43/44
HFS-8x0 303 150 A xx43 Y3 (M)	GKS-051 303 150 A xx00	43/44
HFS-8x0 303 150 A xx43 Y5 (M)	GKS-051 303 150 A xx00	47/48
HFS-8x0 307 100 A xx02 V2-36S (4M)	GKS-051 307 100 A 0000	177/178
HFS-8x0 308 080 A xx42 GT16-F (4M)	GKS-051 308 080 A xx00	119/120
HFS-8x0 308 080 A xx42 X4 (M)	GKS-051 308 080 A 1000 K1	38/39
HFS-8x0 308 080 A xx42 ZE (M)	GKS-051 308 080 A xx00	45/46
HFS-8x0 308 080 A xx42 ZE3 (M)	GKS-051 308 080 A xx00	113/114
HFS-8x0 308 080 A xx43 T (M)	GKS-051 308 080 A xx00	77/78
HFS-8x0 308 080 A xx43 X (M)	GKS-051 308 080 A xx00	38/39
HFS-8x0 308 110 A xx42 BX (M)	GKS-051 308 110 A xx00 K1	28/29
HFS-8x0 308 180 A xx42 E (M)	GKS-051 308 180 A xx00	65/66
HFS-8x0 308 180 A xx42 MBX (M)	GKS-051 308 180 A xx00	35/36
HFS-8x0 308 180 A xx43 E (M)	GKS-051 308 180 A xx00	65/66
HFS-8x0 204 051 A xx02 V2 (4M)	UKS-051 204 051 A	171/174
HFS-8x0 358 080 A xx02 V2-09S (4M)	GKS-051 358 080 A 0000 L	171/174
HFS-8x0 358 080 A xx42 Z (M)	GKS-051 358 080 A xx00	31/32
HFS-8x0 358 180 A xx42 QS (M)	GKS-051 358 180 A xx00	75/76
HFS-819 303 090 A xxx43 F2-Z	GKS-051 303 090 A 1300*	125
HFS-819 303 090 A xxx43 RV5	GKS-051 303 090 A 1300*	124
HFS-819 303 090 A xxx43 RV5-Z	GKS-051 303 090 A 1300*	126
HFS-819 303 090 A xxx43 RV7-Z	GKS-051 303 090 A 1300	126
HFS-819 303 090 A xxx43 V2	GKS-051 303 090 A 1300*	124
HFS-819 303 090 A xxx43 V2-Z	GKS-051 303 090 A 1300*	126
HFS-819 319 090 A xxx43 RV5-H3	GKS-051 319 090 A 1300	127
HFS-819 355 051 A xxx42 V8 (-Z)	GKS-051 355 051 A 1300 L1*	128
HFS-821 302 045 A 9905 MX48	not interchangeable	131
HFS-821 302 045 A 9905 MX68	not interchangeable	134
HFS-821 305 080 A 9905 MX38	not interchangeable	130
HFS-821 305 080 A 9905 MX49	not interchangeable	132
HFS-821 305 080 A 9905 MX62	not interchangeable	133
HFS-821 313 050 A 9905 USB Mini	not interchangeable	129
HFS-822 303 051 A 5043 MM5829	GKS-051 303 051 A1000 MM5829	98

Note: "xx" within the Part No. of the Inner Conductor.

The Inner Conductor is available with various Spring Forces. The character "xx" for the Ordering Description of the Inner Conductor can be taken from the applicable catalog page of the RF Probe series – as Spring Force at working stroke of the Inner Conductor.

Example: GKS-051 201 051 A xx 00
Spring Force at working stroke of the Inner Conductor (N): 1.3 N 2.0 N
Character of the Ordering Description of the Inner Conductor: **13 20**
Example Part No. Inner Conductor with 1.3 N: GKS-051 201 051 A **13** 00
Example Part No. Inner Conductor with 2.0 N: GKS-051 201 051 A **20** 00

Note: To exchange the Inner Conductor the Outer Plunger of the RF Probe must be screwed off. See page 152 for tools for assembly and de-assembly.

Tip styles: Inner Conductor



Note: The recommended Inner Conductors are matched up to the RF Probe. Usage of different tip-styles and tip-diameters can negatively influence the high-frequency behavior, respectively the impedance.





INGUN RF Probes according to Part No. and Inner Conductor

Part No. RF Probe	Part No. Inner Conductor	Page
HFS-822 303 051 A xx42 PSMP2	GKS-051 303 150 A 1000 K1	59
HFS-822 303 090 A xx42 SMPL	GKS-051 303 090 A 1000 K1	55
HFS-822 303 090 A xx43 SMPM M	GKS-051 303 090 A 1000 K1	57
HFS-822 303 090 A xx43 UFL	GKS-051 303 090 A 1000 UFL	93
HFS-822 303 150 A xx43 MBXF	GKS-051 303 150 A 1000 K1	34
HFS-822 308 140 A xx43 SMPM F	GKS-051 308 140 A 1000 K1	58
HFS-822 308 180 A xx42 MBX2	GKS-051 308 180 A 1000 K1	37
HFS-823 305 040 A 6043 MM310	GKS-051 305 040 A 2000 K3 MM31	142
HFS-823 305 051 A 6043 MM036	GKS-051 305 051 A 2000 K3 MM03	145
HFS-823 305 051 A 6043 MS03	GKS-051 305 051 A 2000 K3 MS03	147
HFS-823 305 051 A 6043 MS06	GKS-051 305 051 A 2000 K3 MS06	147
HFS-836 288 120 A 4588 A51F50L	GKS-075 288 120 A 2000	173
HFS-836 288 120 A 4588 A51R50L	GKS-075 288 120 A 2000	175
HFS-837 201 030 A 4823 F05	not interchangeable	176
HFS-837 201 030 A 4823 F10	not interchangeable	166
HFS-852 303 051 A 4043 UFL	not interchangeable	94
HFS-856 303 051 A 5042 SMP	not interchangeable	54
HFS-856 303 051 A 5543 UFL	not interchangeable	95
HFS-856 305 030 A 5543 MM8030	not interchangeable	143
HFS-856 305 030 A 6343 MS180	not interchangeable	150
HFS-856 305 040 A 6343 MS156	not interchangeable	148
HFS-856 379 030 A 5543 XFL	not interchangeable	97
HFS-858 201 051 A 5302	GKS-051 201 051 A 1300	179
HFS-858 201 051 A 5306 S	GKS-051 201 051 A 1300	180
HFS-860 201 051 A xx06 P (4M)	GKS-051 201 051 A xx00	163
HFS-860 201 051 A xx06 S (4M)	GKS-051 201 051 A xx00	160
HFS-860 303 074 A xx43 Y6 (M)	GKS-051 303 074 A xx00	92
HFS-860 303 090 A xx42 SSMP (M)	GKS-051 303 090 A 1300 N10	56
HFS-860 303 150 A xx43 ER (M)	GKS-051 303 150 A xx00	101
HFS-860 305 051 A xx43 Y80 (M)	GKS-051 305 051 A xx00	149
HFS-860 305 051 A xx43 Y82 (M)	GKS-051 355 051 A xx00 L1	146
HFS-860 308 090 A xx42 X (M)	GKS-051 308 090 A xx00	40
HFS-860 308 180 A xx43 E (M)	GKS-051 308 180 A xx00	67
HFS-860 308 180 A xx43 QMA (M)	GKS-051 308 180 A xx00	70
HFS-860 353 051 A xx43 Y52 (M)	GKS-051 353 051 A xx00	96
HFS-860 358 300 A xx42 Q (M)	GKS-051 358 300 A xx00 Q	82
HFS-864 342 700 A 28643 F716	not interchangeable	85
HFS-865 303 090 A xx42 PX F	not interchangeable	60
HFS-865 308 080 A xx42 MMPPF	not interchangeable	33
HFS-865 308 110 A xx43 E1 F	not interchangeable	68
HFS-865 308 110 A xx43 E2 F	not interchangeable	69
HFS-865 308 127 A xx42 BXF	not interchangeable	30
HFS-865 313 050 A xx43 MM1	not interchangeable	144













Accessories	Page
Spacer for receptacle	195
Inner conductor	202
Cable plug assemblies (SE)	196
Receptacles (KS)	192
Tools	200









- * HFS-819... requires four of these Inner Conductors
- ** Inner Conductor incl. Isolation part
- *** Tip style "19":
Alternative tip style to "03", with 1.50 mm (Width of slit 0.2 mm). Available for the Inner Conductor GKS-051.../GKS-051...K1
Part No.:
GKS-051 319 150 A xx00 (K1)

INGUN RF Probes according to Type of Contacting/ Interface

Type of Contacting and Interface	Part No. RF Probe	Frequency range	Page
1.0/2.3-f	HFS-4(8)x0 308 080 A xx43 T (M)	2/4 GHz	77/78
7/16-f	HFS-864 342 700 A 28643 F716	7,5 GHz	85
BMA-m	HFS-4(8)x0 303 150 A xx02 D (M)	2/4 GHz	73/74
BNC-f	HFS-4(8)x0 358 180 A xx42 QS (M)	2/4 GHz	75/76
Dipol	HFS-010 35x 050 A 200x A	Dipole	187
Dipol	HFS-110 30x 050 A 300x x	Dipole	188
Dipol	DPS-215 304 027 A 2006 M	Dipole	189
Dipol	DPS-465 3xx 050 A 400x M	Dipole	190
FAKRA-f	HFS-4(8)x0 308 080 A xx42 ZE3 (M)	2/4 GHz	113/114
FAKRA-m	HFS-4(8)x0 303 150 A xx42 F (M)	2/4 GHz	111/112
FAKRA-m	HFS-4(8)x0 303 150 A xx42 FS1 (M)	2/4 GHz	111/112
FAKRA-m	HFS-4(8)x0 303 150 A xx42 RF3 (M)	2/4 GHz	111/112
F-f	HFS-409 305 100 A 8343 MF	1,5 GHz	108
FME-m	HFS-4(8)x0 303 150 A xx42 W (M)	2/4 GHz	83/84
GT13-m	HFS-4(8)x0 303 090 A xx40 GT13 (4M)	2/4 GHz	115/116
GT16-f	HFS-4(8)x0 308 080 A xx42 GT16-F (4M)	2/4 GHz	119/120
GT16-m	HFS-4(8)x0 303 090 xx42 GT16 (M)	2/4 GHz	117/118
HDMI-f 	34814 (PS-HDMI)	Gbit/s	136
HSD-f	HFS-819 355 051 A xxx42 V8 (-Z)	Gbit/s	128
HSD-m	HFS-819 303 090 A xxx43 V2	Gbit/s	124
HSD-m	HFS-819 303 090 A xxx43 RV5	Gbit/s	124
HSD-m	HFS-819 303 090 A xxx43 F2-Z	Gbit/s	125
HSD-m	HFS-819 303 090 A xxx43 V2-Z	Gbit/s	126
HSD-m	HFS-819 303 090 A xxx43 RV5-Z	Gbit/s	126
HSD-m	HFS-819 303 090 A xxx43 RV7-Z	Gbit/s	126
HSD-m	HFS-819 319 090 A xxx43 RV5-H3	Gbit/s	127
IEC-f	HFS-409 306 350 8342 M	1,5 GHz	107
IEC-m	HFS-409 306 350 8343 M	1,5 GHz	107
MBX-f	HFS-4(8)x0 308 180 A xx42 MBX (M)	2/4 GHz	35/36
MBX-f	HFS-822 308 180 A xx42 MBX2	6 GHz	37
MBX-m 	HFS-822 303 150 A xx43 MBXF	6 GHz	34
MCX-f	HFS-4(8)x0 308 080 A xx42 X4 (M)	2/4 GHz	38/39
MCX-f	HFS-4(8)x0 308 080 A xx43 X (M)	2/4 GHz	38/39
MCX-f	HFS-860 308 090 A xx42 X (M)	6 GHz	40
Mini-SMP-m 	HFS-860 303 090 A xx42 SSMP (M)	6 GHz	56
MM5829 	HFS-822 303 090 A 5043 MM5829	6 GHz	98
MM8030	HFS-823 305 040 A 6043 MM310	6 GHz	142
MM8030	HFS-856 305 030 A 5543 MM8030	6 GHz	143
MM8030	HFS-865 313 050 A xx43 MM	12 GHz	144
MM8130/8430	HFS-823 305 051 A 6043 MM036	6 GHz	145
MM8130/8430	HFS-860 305 051 A xx43 Y80 (M)	6 GHz	146
MM8130/8430	HFS-860 305 051 A xx43 Y82 (M)	6 GHz	146
MMBX-f	HFS-865 308 127 A xx42 BXF	12 GHz	30
MMBX-f	HFS-4(8)x0 308 110 A xx42 BX(M)	2/4 GHz	28/29
MMCX-f	HFS-4(8)x0 358 080 A xx42 Z (M)	2/4 GHz	31/32
MMPX-f 	HFS-865 308 080 A xx42 MMPF	12 GHz	33
MS-156 (HF) / MS-156 C	HFS-823 305 051 A 6043 MS03	6 GHz	147
MS-156 (HF) / MS-156 C	HFS-823 305 051 A 6043 MS06	6 GHz	147
MS-156 (HF) / MS-156 C	HFS-856 305 040 A 6343 MS156	6 GHz	148

INGUN RF probes according to Type of Contacting/ Interface

Type of Contacting and Interface	Part No. RF Probe	Frequency range	Page
MS-156 (HF) / MS-156 C	HFS-860 305 051 A xx43 Y80 (M)	6 GHz	149
MS-156 (HF) / MS-156 C	HFS-860 305 051 A xx43 Y82 (M)	6 GHz	149
MS-180 	HFS-856 305 030 A 6343 MS180	6 GHz	150
MX38 	HFS-821 305 080 A 9905 MX38	Gbit/s	130
MX48 	HFS-821 302 045 A 9905 MX48	Gbit/s	131
MX49	HFS-821 305 080 A 9905 MX49	Gbit/s	132
MX62 	HFS-821 305 080 A 9905 MX62	Gbit/s	133
MX68 	HFS-821 302 045 A 9905 MX68	Gbit/s	134
N-f	HFS-4(8)10 358 180 A xx42 Q (M)	2 GHz	81
N-f	HFS-860 358 300 A xx42 Q (M)	6 GHz	82
PC3.5-f	HFS-865 308 110 A xx43 E2 F	12 GHz	69
PCB-GGSGG	HFS-4(8)x0 307 100 A xx02 V2-36S (4M)	2/4 GHz	177/178
PCB-GGSGG	HFS-4(8)x0 204 051 A xx02 V2-360 (4M)	2/4 GHz	177/178
PCB-GSG	HFS-4(8)x0 201 051 A xx29 V2 (4M)	2/4 GHz	170/172
PCB-GSG	HFS-4(8)x0 201 051 A xx29 V2-Sx (4M)	2/4 GHz	170/172
PCB-GSG	HFS-4(8)x0 358 080 A xx02 V2-09S (4M)	2 GHz	171/174
PCB-GSG	HFS-4(8)x0 204 051 A xx02 V2 (4M)	2 GHz	171/174
PCB-GSG	HFS-836 288 120 A 4588 A51F50L	4 GHz	173
PCB-GSG	HFS-836 288 120 A 4588 A51R50L	4 GHz	175
PCB-GSG	HFS-837 201 030 A 4823 F05	12 GHz	176
PCB-koax-closed	HFS-4(8)x0 201 051 A xx02 (M)	2/4 GHz	156/157
PCB-koax-closed	HFS-4(8)x0 201 051 A xx06 (M)	2/4 GHz	156/157
PCB-koax-closed (75 Ω)	HFS-858 201 051 A 5302	1 GHz	179
PCB-koax-kidney-shaped	HFS-4(8)x0 201 051 A xx06 P (4M)	2/4 GHz	161/162
PCB-koax-kidney-shaped	HFS-860 201 051 A xx06 P (4M)	6 GHz	163
PCB-koax-open	HFS-4(8)x0 201 051 A xx02 S (4M)	2/4 GHz	158/159
PCB-koax-open	HFS-4(8)x0 201 051 A xx06 S (4M)	2/4 GHz	158/159
PCB-koax-open	HFS-860 201 051 A xx06 S (4M)	6 GHz	160
PCB-koax-open (75 Ω)	HFS-858 201 051 A 5306 S	1 GHz	180
PCB-lateral	HFS-4(8)x0 201 051 A xx14 VZ (4M)	2/4 GHz	183
PCB-lateral	HFS-4(8)x0 201 051 A xx29 V2-VZ (4M)	2/4 GHz	184
PCB-SG	HFS-4(8)x0 204 051 A xx02 V1-AS3 (4M)	2/4 GHz	164/165
PCB-SG	HFS-4(8)x0 358 051 A xx02 V2-00S (4M)	2/4 GHz	164/165
PCB-SG	HFS-837 201 030 A 4823 F10	12 GHz	166
PCB-SG-filter	HFS-4(8)40 007 051 A xx07 Px-AS (4M)	4 GHz	169
Pico II, PN 1551372-1 	HFS-823 305 040 A 6043 MM310	6 GHz	151
Power DC-f 	35640 (PS-PowerDC)	Gbit/s	136
P-SMP-m 	HFS-822 303 090 A xx42 PSMP2	6 GHz	59
QMA-f	HFS-860 308 180 A xx43 QMA (M)	6 GHz	70
RJ-10 	17824 (PS-RJ)	Gbit/s	137
RJ-12 	17825 (PS-RJ)	Gbit/s	137
RJ-45 	17826 (PS-RJ)	Gbit/s	137
RJ-50 	17827 (PS-RJ)	Gbit/s	137
R-SMA-m	HFS-860 303 150 A xx43 ER (M)	6 GHz	101
R-TNC-m	HFS-4(8)x0 303 150 A xx43 QN (M)	2/4 GHz	102/103
SMA-f	HFS-4(8)x0 308 180 A xx42 E (M)	2/4 GHz	65/66
SMA-f	HFS-4(8)x0 308 180 A xx43 E (M)	2/4 GHz	65/66
SMA-f	HFS-860 308 180 A xx43 E (M)	6 GHz	67
SMA-f	HFS-865 308 110 A xx43 E1 F	12 GHz	68

Type of Contacting and Interface	Part No. RF Probe	Frequency range	Page
SMA-m	HFS-4(8)x0 303 150 A xx43 E3 (M)	2/4 GHz	63/64
SMB-f	HFS-4(8)x0 308 080 A xx42 ZE (M)	2/4 GHz	45/46
SMB-m	HFS-4(8)x0 303 150 A xx43 Y (M)	2/4 GHz	43/44
SMB-m	HFS-4(8)x0 303 150 A xx43 Y2 (M)	2/4 GHz	43/44
SMB-m	HFS-4(8)x0 303 150 A xx43 F-Y14 (M)	2/4 GHz	43/44
SMB-m	HFS-4(8)x0 303 150 A xx43 Y3 (M)	2/4 GHz	43/44
SMC-m	HFS-4(8)x0 303 150 A xx43 Y5 (M)	2/4 GHz	47/48
SMP-L-m 	HFS-822 303 090 A xx42 SMPL	6 GHz	55
SMP-m	HFS-4(8)x0 303 150 A xx42 E (M)	2/4 GHz	52/53
SMP-m 	HFS-856 303 051 A 5042 SMP	6 GHz	54
SMP-MAX-f	HFS-822 308 140 A xx43 SMPM F	6 GHz	58
SMP-MAX-m	HFS-822 303 090 A xx42 SMPM M	6 GHz	57
SMPX-m	HFS-865 303 090 A xx42 PX F	12 GHz	60
TAE-f 	34847 (PS-TAE)	Gbit/s	136
U.FL-m	HFS-4(8)x0 303 090 A xx43 Y6 (M)	2/4 GHz	90/91
U.FL-m	HFS-860 303 074 A xx43 Y6 (M)	6 GHz	92
U.FL-m	HFS-822 303 090 A xx43 UFL	6 GHz	93
U.FL-m	HFS-852 303 051 A 4043 UFL	6 GHz	94
U.FL-m	HFS-856 303 051 A 5543 UFL	6 GHz	95
USB Micro-f (type B) 	34816 (PS-USB)	Gbit/s	136
USB Mini-f 	HFS-821 313 050 A 9905 USB Mini	Gbit/s	129
USB Mini-f (type B) 	21072 (PS-USB)	Gbit/s	136
USB-f (type A) 	21071 (PS-USB)	Gbit/s	136
USB-f (type B) 	17829 (PS-USB)	Gbit/s	136
W.FL-m	HFS-860 353 051 A xx43 Y52 (M)	6 GHz	96
W.FL-m	HFS-856 379 030 A 5543 XFL	6 GHz	97
W.FL2-m	HFS-860 353 051 A xx43 Y52 (M)	6 GHz	96
W.FL2-m	HFS-856 379 030 A 5543 XFL	6 GHz	97
X.FL-m	HFS-860 353 051 A xx43 Y52 (M)	6 GHz	96
X.FL-m	HFS-856 379 030 A 5543 XFL	6 GHz	97

Nomenclature	
f	female = Signal Conductor Jack
m	male = Signal Conductor Plug
S	Signal
G	Ground
Example: GSG	2 Ground Pins, 1 Signal Pin
xx / xxx	Spring Force Variants
HFS-4(8)10	Part No. available as HFS-410 and HFS-810 available
HFS-4(8)40	Part No. available as HFS-440 and HFS-840 available
HFS-4(8)x0	Part No. available as 410 (810) or 440 (840) available (2 respectively 4 GHz)
HFS-...(M)	Part No. additionally available as screw-in version
HFS-...(4M)	Part No. additionally available as adjustable screw-in version

INGUN RF-Probes according to Part No.

RF-Probes Part No.		Page	RF-Probes Part No.		Page
17824 (PS-RJ)	NEW	137	HFS-4(8)x0 308 080 A xx42 GT16-F (4M)		119/120
17825 (PS-RJ)	NEW	137	HFS-4(8)x0 308 080 A xx42 X4 (M)		38/39
17826 (PS-RJ)	NEW	137	HFS-4(8)x0 308 080 A xx42 ZE (M)		45/46
17827 (PS-RJ)	NEW	137	HFS-4(8)x0 308 080 A xx42 ZE3 (M)		113/114
17829 (PS-USB)	NEW	136	HFS-4(8)x0 308 080 A xx43 T (M)		77/78
21071 (PS-USB)	NEW	136	HFS-4(8)x0 308 080 A xx43 X (M)		38/39
21072 (PS-USB)	NEW	136	HFS-4(8)x0 308 110 A xx42 BX(M)		28/29
34814 (PS-HDMI)	NEW	136	HFS-4(8)x0 308 180 A xx42 E (M)		65/66
34816 (PS-USB)	NEW	136	HFS-4(8)x0 308 180 A xx42 MBX (M)		35/36
34847 (PS-TAE)	NEW	136	HFS-4(8)x0 308 180 A xx43 E (M)		65/66
35640 (PS-PowerDC)	NEW	136	HFS-4(8)x0 204 051 A xx02 V2 (4M)		171/174
DPS-215 304 027 A 2006 M	NEW	189	HFS-4(8)x0 358 080 A xx02 V2-09S (4M)		171/174
DPS-465 3xx 050 A 400x M	NEW	190	HFS-4(8)x0 358 080 A xx42 Z (M)		31/32
HFS-010 35x 050 A 200x A		187	HFS-4(8)x0 358 180 A xx42 QS (M)		75/76
HFS-110 30x 050 A 300x x		188	HFS-409 305 100 A 8343 MF		108
HFS-4(8)10 358 180 A xx42 Q (M)		81	HFS-409 306 350 8342 M		107
HFS-4(8)40 007 051 A xx07 Px-AS (4M)		169	HFS-409 306 350 8343 M		107
HFS-4(8)x0 201 051 A xx02 (M)		156/157	HFS-819 303 090 A xxx43 F2-Z		125
HFS-4(8)x0 201 051 A xx02 S (4M)		158/159	HFS-819 303 090 A xxx43 RV5		124
HFS-4(8)x0 201 051 A xx06 (M)		156/157	HFS-819 303 090 A xxx43 RV5-Z		126
HFS-4(8)x0 201 051 A xx06 P (4M)		161/162	HFS-819 303 090 A xxx43 RV7-Z	NEW	126
HFS-4(8)x0 201 051 A xx06 S (4M)		158/159	HFS-819 303 090 A xxx43 V2		124
HFS-4(8)x0 201 051 A xx14 VZ (4M)		183	HFS-819 303 090 A xxx43 V2-Z		126
HFS-4(8)x0 201 051 A xx29 V2 (4M)		170/172	HFS-819 319 090 A xxx43 RV5-H3	NEW	127
HFS-4(8)x0 201 051 A xx29 V2-Sx (4M)		170/172	HFS-819 355 051 A xxx42 V8 (-Z)		128
HFS-4(8)x0 201 051 A xx29 V2-VZ (4M)		184	HFS-821 302 045 A 9905 MX48	NEW	131
HFS-4(8)x0 204 051 A xx02 V1-AS3 (4M)		164/165	HFS-821 302 045 A 9905 MX68	NEW	134
HFS-4(8)x0 358 051 A xx02 V2-00S (4M)		164/165	HFS-821 305 080 A 9905 MX38	NEW	130
HFS-4(8)x0 204 051 A xx02 V2-360 (4M)		177/178	HFS-821 305 080 A 9905 MX49		132
HFS-4(8)x0 303 090 A xx40 GT13 (4M)		115/116	HFS-821 305 080 A 9905 MX62	NEW	133
HFS-4(8)x0 303 090 A xx43 Y6 (M)		90/91	HFS-821 313 050 A 9905 USB Mini	NEW	129
HFS-4(8)x0 303 090 xx42 GT16 (M)		117/118	HFS-822 303 090 A 5043 MM5829	NEW	98
HFS-4(8)x0 303 150 A xx02 D (M)		73/74	HFS-822 303 090 A xx42 PSMP2	NEW	59
HFS-4(8)x0 303 150 A xx42 E (M)		52/53	HFS-822 303 090 A xx42 SMPL	NEW	55
HFS-4(8)x0 303 150 A xx42 F (M)		111/112	HFS-822 303 090 A xx42 SMPM M		57
HFS-4(8)x0 303 150 A xx42 FS1 (M)		111/112	HFS-822 303 090 A xx43 UFL	NEW	93
HFS-4(8)x0 303 150 A xx42 RF3 (M)		111/112	HFS-822 303 150 A xx43 MBXF	NEW	34
HFS-4(8)x0 303 150 A xx42 W (M)		83/84	HFS-822 308 140 A xx43 SMPM F		58
HFS-4(8)x0 303 150 A xx43 E3 (M)		63/64	HFS-822 308 180 A xx42 MBX2	NEW	37
HFS-4(8)x0 303 150 A xx43 F-Y14 (M)		43/44	HFS-823 305 040 A 6043 MM310	NEW	142
HFS-4(8)x0 303 150 A xx43 QN (M)		102/103	HFS-823 305 040 A 6043 MM310	NEW	151
HFS-4(8)x0 303 150 A xx43 Y (M)		43/44	HFS-823 305 051 A 6043 MM036	NEW	145
HFS-4(8)x0 303 150 A xx43 Y2 (M)		43/44	HFS-823 305 051 A 6043 MS03	NEW	147
HFS-4(8)x0 303 150 A xx43 Y3 (M)		43/44	HFS-823 305 051 A 6043 MS06	NEW	147
HFS-4(8)x0 303 150 A xx43 Y5 (M)		47/48	HFS-836 288 120 A 4588 A51F50L	NEW	173
HFS-4(8)x0 307 100 A xx02 V2-36S (4M)		177/178	HFS-836 288 120 A 4588 A51R50L	NEW	175

RF-Probes Part No.		Page
HFS-837 201 030 A 4823 F05	NEW	176
HFS-837 201 030 A 4823 F10	NEW	166
HFS-852 303 051 A 4043 UFL	NEW	94
HFS-856 303 051 A 5042 SMP	NEW	54
HFS-856 303 051 A 5543 UFL	NEW	95
HFS-856 305 030 A 5543 MM8030	NEW	143
HFS-856 305 030 A 6343 MS180	NEW	150
HFS-856 305 040 A 6343 MS156	NEW	148
HFS-856 379 030 A 5543 XFL	NEW	97
HFS-858 201 051 A 5302		179
HFS-858 201 051 A 5306 S		180
HFS-860 201 051 A xx06 P (4M)		163
HFS-860 201 051 A xx06 S (4M)		160
HFS-860 303 074 A xx43 Y6 (M)		92
HFS-860 303 090 A xx42 SSMP (M)	NEW	56
HFS-860 303 150 A xx43 ER (M)		101
HFS-860 305 051 A xx43 Y80 (M)		146
HFS-860 305 051 A xx43 Y80 (M)		149
HFS-860 305 051 A xx43 Y82 (M)		146
HFS-860 305 051 A xx43 Y82 (M)		149
HFS-860 308 090 A xx42 X (M)		40
HFS-860 308 180 A xx43 E (M)		67
HFS-860 308 180 A xx43 QMA (M)		70
HFS-860 353 051 A xx43 Y52 (M)		96
HFS-860 358 300 A xx42 Q (M)		82
HFS-864 342 700 A 28643 F716	NEW	85
HFS-865 303 090 A xx42 PX F		60
HFS-865 308 080 A xx42 MMPPF	NEW	33
HFS-865 308 110 A xx43 E1 F		68
HFS-865 308 110 A xx43 E2 F		69
HFS-865 308 127 A xx42 BXF		30
HFS-865 313 050 A xx43 MM1		144

Accessories	Page
Spacer for receptacle	195
Inner conductor	202
Cable plug assemblies (SE)	196
Receptacles (KS)	192
Tools	200

Nomenclature	
f	female = Signal Conductor Jack
m	male = Signal Conductor Plug
S	Signal
G	Ground
Beispiel: GSG	2 Ground Pins, 1 Signal Pin
xx	Spring Force Variants
HFS-4(8)10	Part No. available as HFS-410 and HFS-810 available
HFS-4(8)40	Part No. available as HFS-440 and HFS-840 available
HFS-...(M)	Part No. additionally available as screw-in version
HFS-...(4M)	Part No. additionally available as adjustable screw-in version

Headquarters

INGUN Germany

Subsidiaries

INGUN Benelux
INGUN China
INGUN India
INGUN Korea
INGUN Mexico
INGUN España
INGUN Switzerland
INGUN UK
INGUN USA

Europe

Austria
Benelux
Bosnia-Herzegovina
Croatia
Czech Republic
Denmark
Estonia
Finland
France
Germany
Hungary
Italy
Norway
Poland
Portugal
Romania
Serbia
Slovenia
Slovak Republic
Spain
Sweden
Switzerland
Turkey
United Kingdom

Asia

China
Hongkong
India
Israel
Japan
Korea
Malaysia
Taiwan
Thailand
Vietnam

Africa

South Africa
Tunisia

Australia

Australia
New Zealand

America

Argentina
Brazil
Canada
Mexico
USA

The addresses of our international agencies can be found under www.ingun.com

ingun[®]

INGUN Prüfmittelbau GmbH

Max-Stromeyer-Straße 162

78467 Konstanz

Germany

Tel. +49 7531 8105-0

Fax +49 7531 8105-65

info@ingun.com

www.ingun.com